



# **T-SERIES HOT FOOD HOLDING CABINETS**

---

## **USER MANUAL**

**THIS MANUAL COVERS CABINETS  
WITH ELECTRICAL  
RATINGS OF: 120V 1400W &  
220-240V 1176-1400W**

When ordering electrical parts, always confirm the rating listed on cabinet data plate on back of cabinet.

Differences in voltage, amps or wattage are listed with **BOLD TEXT** in replacement part descriptions.

**Metro Heated Cabinets are for  
Hot Food Holding applications only**



We put space to work.™

**InterMetro Industries Corporation**

North Washington Street, Wilkes-Barre, PA 18705

For Product Information Call: 1-800-992-1776,

**Visit Our Web Site: [www.metro.com](http://www.metro.com)**



# TABLE OF CONTENTS

SAFETY INFORMATION .....	2
SAFETY SYMBOLS .....	2
IDENTIFY YOUR CABINET .....	2
PRODUCT FEATURES .....	3
INSTALLATION AND SETUP .....	5
OPERATING INSTRUCTIONS (DIGITAL CONTROLLER) .....	8
OPERATING INSTRUCTIONS (ANALOG CONTROLLER) .....	11
HANDLING INSTRUCTIONS FOR TRANSPORTING CABINET .....	12
CARE AND MAINTENANCE .....	12
BASIC TROUBLESHOOTING .....	13
SERVICE AND REPLACEMENT PARTS .....	14
SERVICE AND REPLACEMENT PARTS (CIRCUITS) .....	18
WARRANTY .....	22

## SAFETY INFORMATION

- WARNING:** This cabinet is only for hot food holding applications.
- WARNING:** Follow all food safety guidelines. Pre-heat the cabinet to the desired temperature before placing hot cooked food into the cabinet. Food must be at the appropriate temperature before being placed into cabinet. Use a food probe to check internal food temperature - the cabinet temperature is not necessarily the internal food temperature.
- WARNING:** Only factory approved service agents should attempt to service, repair or replace electrical components, wiring or power cord.
- WARNING:** Unplug the cabinet before cleaning or servicing. Do not wash the cabinet with a water jet or high pressure water, do not hose wash/spray interior.
- WARNING:** Food Service Equipment must be electrically grounded. Failure to ground Food Service Equipment may result in serious injury or death from electrical malfunction.
- CAUTION:** Do not spray or pour water into the top of the cabinet (control enclosure). Unplug the cabinet before cleaning and then wipe with a damp cloth and dry with a towel. Use only cleaning agents approved for stainless steel.

## SAFETY SYMBOLS



## IDENTIFYING YOUR CABINET

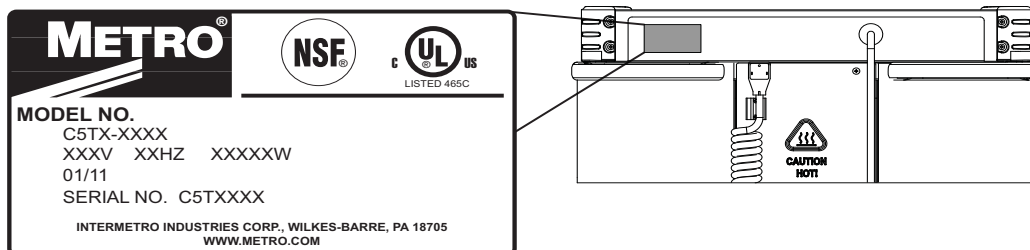

For future reference, note the serial and model number found on the data plate of the cabinet here:

Serial number \_\_\_\_\_

Model number \_\_\_\_\_

Date the cabinet was put into service \_\_\_\_\_

Fill out and return the warranty card located at the back of this manual.

# PART NUMBERING

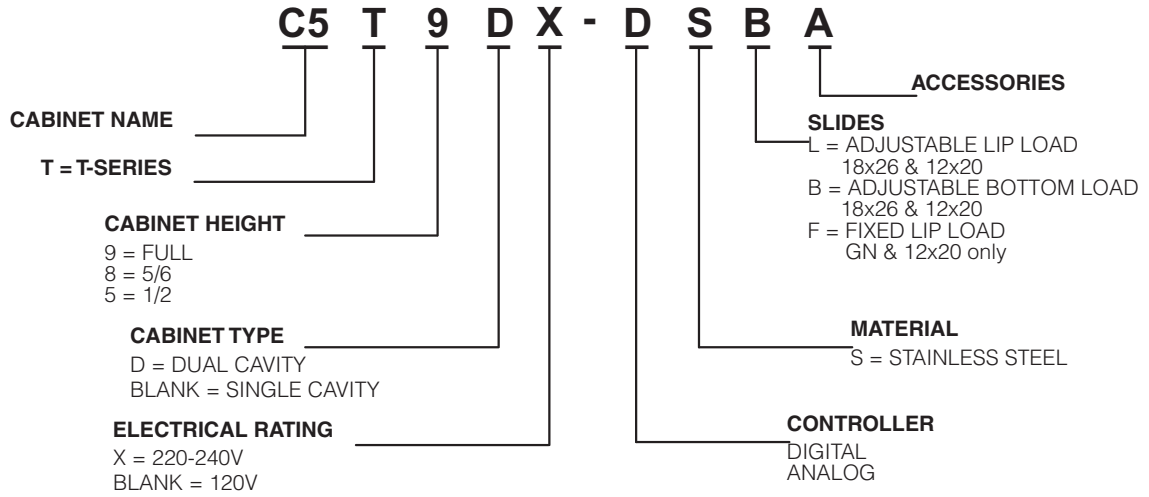

# PRODUCT FEATURES

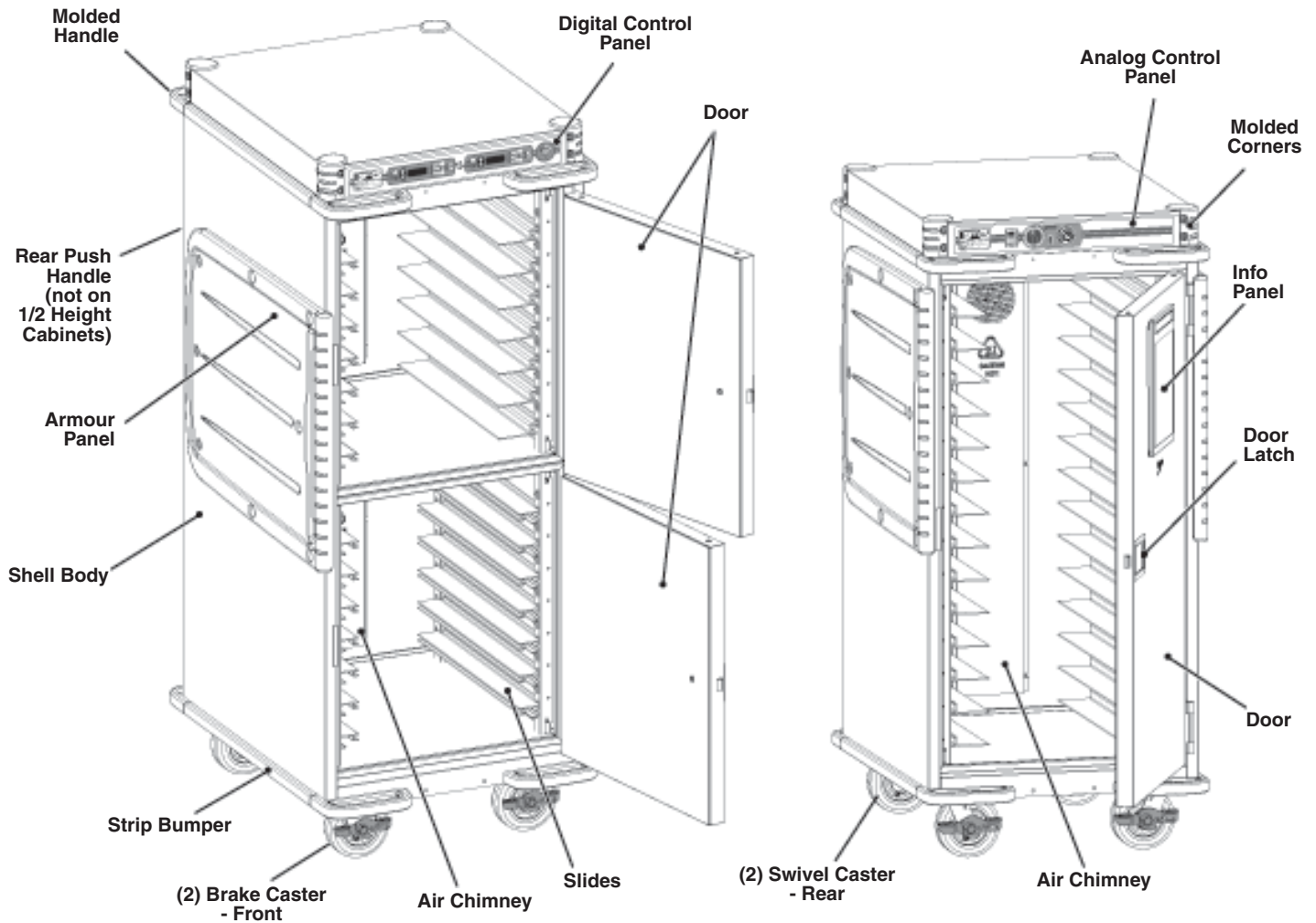

## Digital Controller (Single Cavity Cabinets)

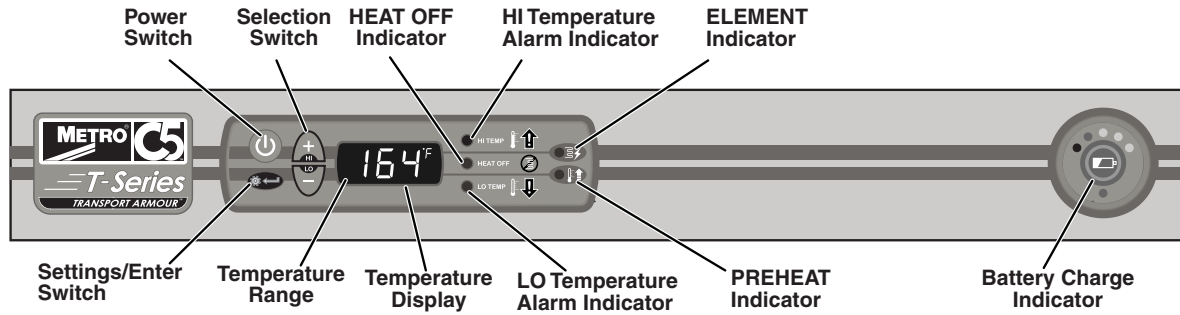

## Analog Controller (Single Cavity Cabinet)

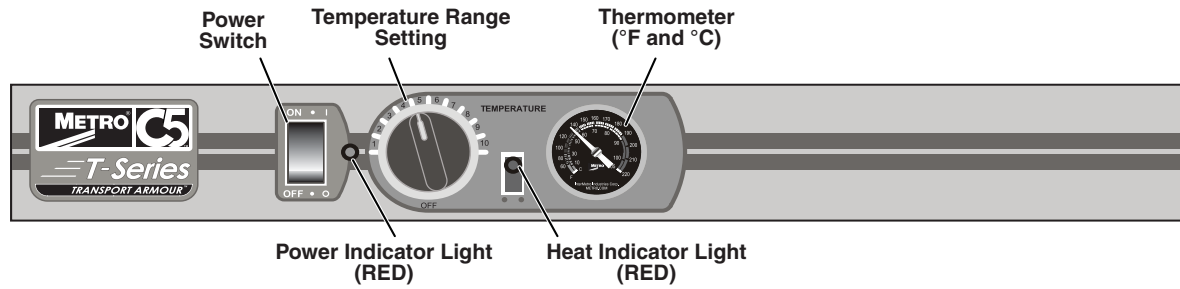

## Digital Controller (Dual Cavity Cabinets)

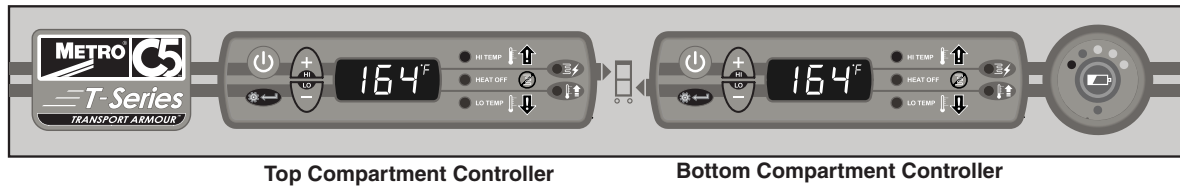

## Analog Controller (Dual Cavity Cabinet)

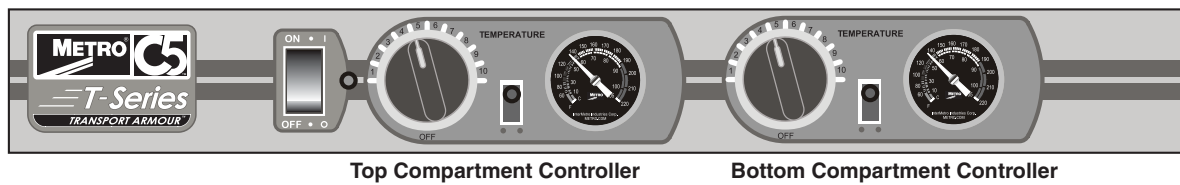

# INSTALLATION AND SETUP

**NOTE:** The First 4 steps below are common to both Analog and Digital cabinets.

1. Check for Shipping Damage: Check the packaging and cabinet for shipping damage before and after unloading the unit, and after removing all packaging materials.
2. The receiver of this product is responsible for filing freight damage claims. This equipment must be opened immediately for inspection. All visible damage must be reported to the freight company within 48 hours and must be noted on freight bill at the time of delivery.
3. Concealed damage is your responsibility — you must advise the carrier of any loss or damage within 15 days after receipt of the cabinet. If there is damage, retain the original packaging for inspectors.
4. After unpacking the cabinet, remove all packing material from the inside as well as outside of the unit.
5. The power cord is located at the back of the cabinet as shown in Figure 1.
6. Refer to the data plate located near the power cord for the electrical specifications of cabinet as shown in Figure 2.

*With the POWER switch OFF, plug the cord into the appropriate rated, grounded receptacle.  
Cabinets rated at 120V 1400W must be plugged into either a 15 amp or 20 amp 125 VAC receptacle.  
Cabinets rated at 220-240V 1176-1400W must be plugged into a 15 amp 250 VAC receptacle.*



**FIGURE 1:  
POWER CORD LOCATION ON CABINET**

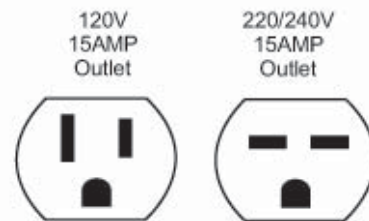
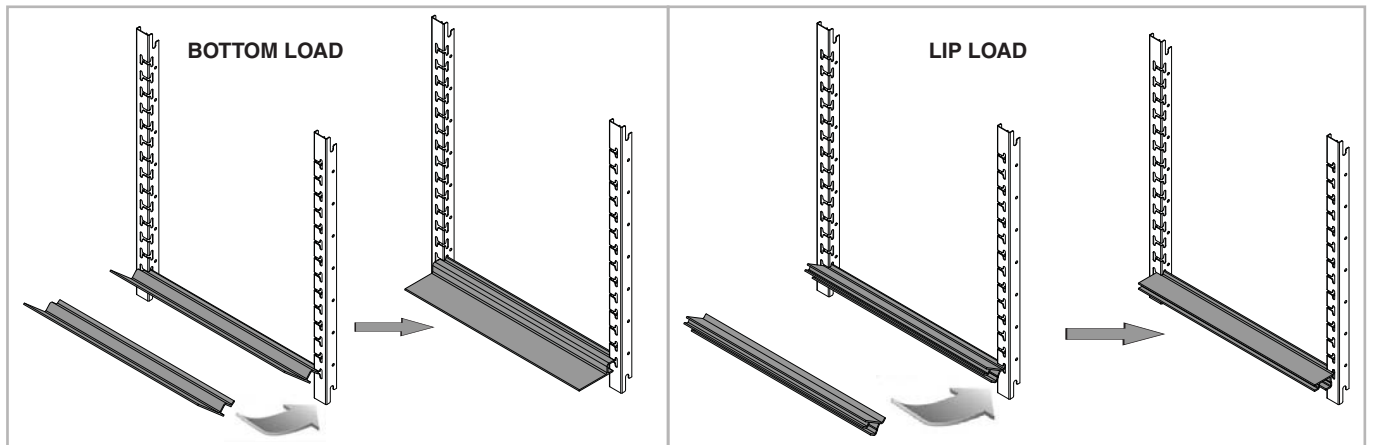

**FIGURE 2:  
C5 T-SERIES WALL RECEPTACLES**

**WARNING:** Do not allow combustible materials to be stored or accumulate on, under or next to the cabinet. Do not block any ventilation louvers or slots.

**CAUTION:** C5 T-Series cabinets (Polymer Armour panels on the sides) must not be placed next to char broilers or Allow 18" (46cm) between the Armour panels and any cooking equipment. Do not allow hot kitchen equipment whose surfaces exceed 200°F (90°C) to touch the panels.

## Slide Installation Adjustable on Uprights (Bottom Load and Lip Load)



## Maximum Capacity of Adjustable Slides (Lip and Bottom Loads)

**NOTE:** Only lip load capacities are shown below. Bottom loads have the same capacities.

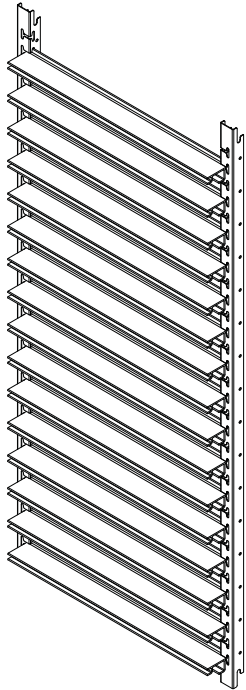

### FULL HEIGHT SINGLE

16 Levels

Position from Bottom

Lip Load Part No. C5T-LL-9, 1PR  
Bottom Load Part No. C5T-BL-9, 1PR

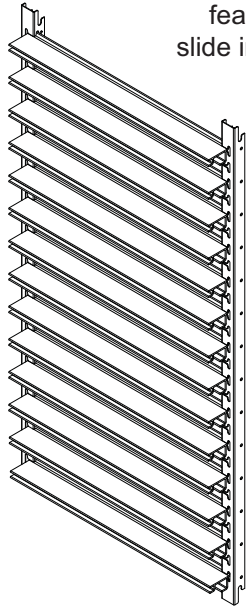

### 5/6 HEIGHT CABINET

14 Levels

Position from Bottom

Lip Load Part No. C5T-LL-8, 1PR  
Bottom Load Part No. C5T-BL-8, 1PR

SiteSelect™  
feature make  
slide installation  
easier.

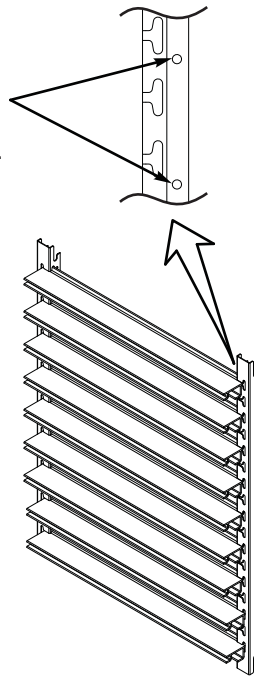

### 1/2 HEIGHT CABINET

9 Levels

Position from Bottom

Lip Load Part No. C5T-LL-5, 1PR  
Bottom Load Part No. C5T-BL-5, 1PR

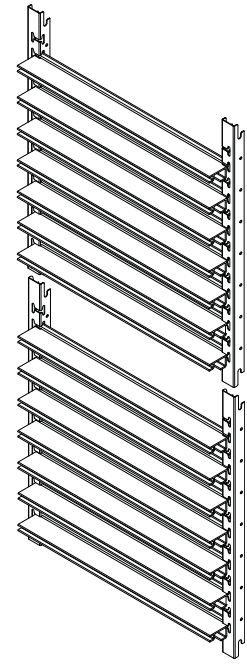

### DUAL CAVITY

7 Levels (14 Total)

Position from Bottom

Lip Load Part No. C5TD-LL-9, 2PR  
Bottom Load Part No. C5TD-BL-5, 2PR

## Installation of Fixed Slide Racks

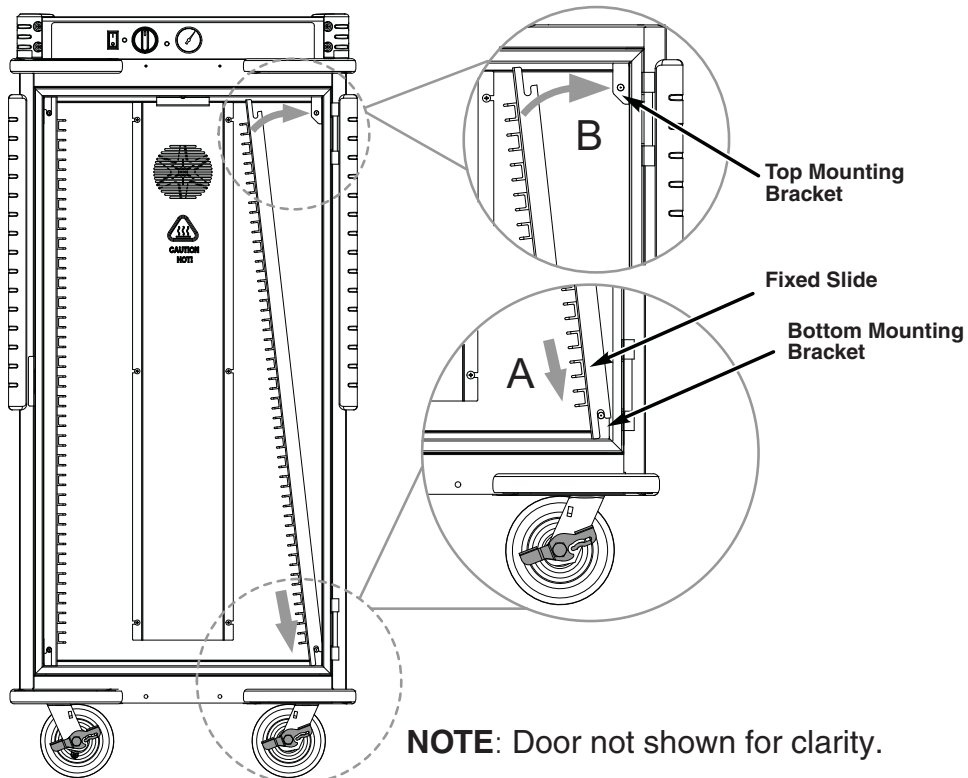

**NOTE:** Door not shown for clarity.

## Fixed Lip Load Slide Configurations

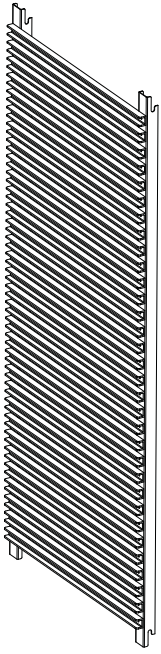

**FULL HEIGHT**  
1-Piece Construction  
Part No. C5T-FS-9, 1PR

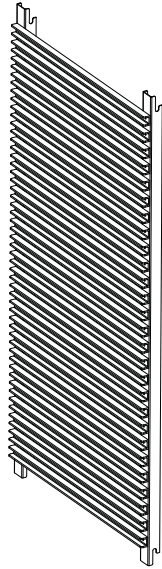

**5/6 HEIGHT**  
1-Piece Construction  
Part No. C5T-FS-8, 1PR

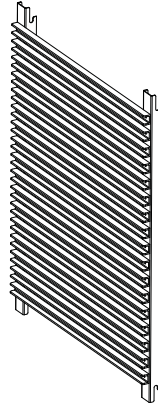

**1/2 HEIGHT**  
1-Piece Construction  
Part No. C5T-FS-5, 1PR

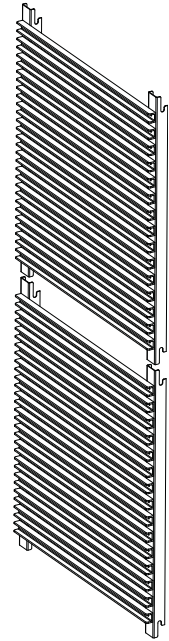

**DUAL CAVITY**  
1-Piece Construction (2 Pairs)  
Part No. C5TD-FS-9, 2PR

## Wire Shelf Installation

**1**

**2**

Insert left side of wireshelf into upright at an angle and then lower right side to level and shift shelf to fit into right side upright.

**3**

**NOTE:** Wireshelf must be used with cabinet uprights

## OPERATING INSTRUCTIONS (DIGITAL CONTROLLER)

**NOTE:** Before using your cabinet for the first time, heat the cabinet to maximum temperature for 15 minutes to burn off oils on stainless from manufacturing process. During this process slight smoke may be seen.

### Power-Up and Pre-Heat

- When the cabinet is switched on, all LEDs and display segments illuminate (blinking) for 3 seconds.
- The display then shows the set point (blinking) for 3 seconds, followed by current temperature.
- The preheat indicator light turns off after the temperature set point is reached. Set point range is 85 – 200 °F (29-93 °C) and “---” indicates one step below 85 °F (29 °C).
- If the set point is “---” (heat off) the pre heat LED will be off. The “heat off” LED will be on.

**NOTE:** The current temperature scale LED (°F or °C) remains illuminated whenever the cabinet is turned on. The “element indicator” LED remains on whenever the circuit is energized.

- During initial pre-heat, the “lo temp” alarm is disabled.
- When plugged in and powered-on, the “Power” display shows the current charge status of the battery. When charging, the uppermost led blinks in 1 second intervals, while all LEDs below it remain on continuously. When the battery is fully charged, all power LEDs are lit continuously.

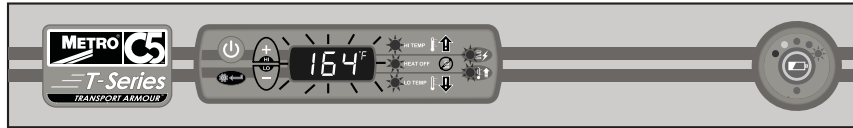

1. Allow the cabinet to pre-heat without food for 30 minutes to an hour. The pre-heat time required to reach the temperature set point is dependent on the set point, the size of the cabinet, the door type (single or dual) and the temperature of the room the cabinet is in.

### Steady State Operation

- Press and release the “+ or –” buttons at any time to change the set points. The first push recalls and displays the current set point. If a button is pressed again within a 4 second period, the set point will be changed by a 1 degree increment. The set point will be displayed for 4 seconds, then shows the current temperature display.
- Press and hold the “+ or –” buttons to recall and display the current set point for 4 seconds. The set point will then change in 1 degree increments every ½ second for the first 5 seconds, then increase in 10 degree increments every ½ second until the button is released. The set point will be displayed for 4 seconds, then shows the current temperature display.

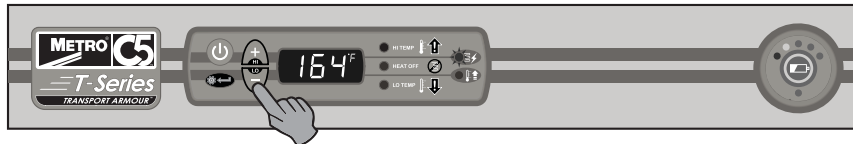

### Unplugged Operation

- When cabinet is unplugged the system begins operation on battery power.  
*Temperature monitoring and air circulation continues up to (3 hours) after the cabinet is un-plugged.*  
*Cabinet displays are turned on when the cabinet is unplugged.*  
*If additional runtime is desired, press power switch to engage controller and fan.*
- Display the current cabinet temperature: Press the “+ or –” button. The display will show the current temperature for as long as the button is depressed. Temperature set points cannot be changed while cabinet is unplugged.
- Display the battery charge status: Press the “battery” button. The display will show the current charge level for as long as the button is depressed.
- Low Temp Alarm: If the cabinet temperature drops below the alarm set point for more than 5 minutes during operation, the display will begin to blink “\_\_\_”, and the “LO TEMP” LED will illuminate (blinking). This will repeat every 10 seconds.
- Hi Temp Alarm: If the cabinet is in “HEAT OFF” mode and the temperature rises above the alarm set point for more than 5 minutes during operation, the display will begin to blink “---”, and the “HI TEMP” LED will illuminate (blinking). This will repeat every 10 seconds.

**NOTE:** Audio (if enabled), Low temp Alarm: (3) 1/2 second beeps, repeating every 10 seconds.

- Average charging time = 1 hour for single cavity and 1½ hours for dual cavity.

- The cabinet will charge any time, when the power cord is plugged-in.

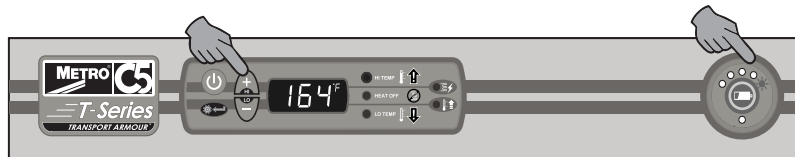

## Low Temperature Alarm

### Checking the low temperature alarm set point

- Press and hold the “Settings” button, followed by the “-” button, then release both. The display shows the current low temperature alarm set point and illuminates the LO TEMP led (blinking) for 5 seconds, before again showing the current cabinet temperature.

### Changing the low temperature alarm set point

- Perform the step listed above.
- Press the “+ or -” buttons within the 5 second period to change the alarm set point. (the same rules that apply to changing the temperature set points also apply here).
- Press the “Settings” button to save the new alarm set point and exit this function, or after 5 seconds with no buttons pressed, the new alarm set point will be automatically saved.

### Low temperature alarm

- If the cabinet temperature drops below the alarm set point for more than 5 minutes during operation, the display will begin to blink, and the “LO TEMP” LED will illuminate (blinking). This will continue until the temperature rises above the low temp set point or the low temp alarm set point is lowered.

**NOTE:** If the cabinet operating temperature is set below the low temperature alarm setting, the alarm is disabled.

**NOTE:** Audio (if enabled), button press produces a 1/4 second “chirp”. Low temp Alarm: (3) 1/2 second beeps, repeating every 10 seconds.

**NOTE:** Set point range is 135–185 °F “----” (off) one step below 135 °F. Default set point is 140 °F

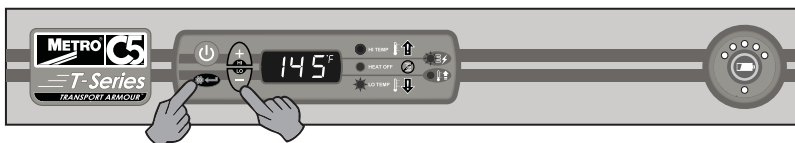

## Hi Temperature Alarm

### Checking the Hi temperature alarm set point:

- Press and hold the “Settings” button, followed by the “+” button, then release both. The display shows the current hi temperature alarm set point and illuminates the “HI TEMP” LED (blinking) for 5 seconds, before again showing the current cabinet temperature.

### Changing the Hi Temp Alarm set point

- Perform the step listed above. Press the “+ or -” buttons within the 5 second period to change the alarm set point. ( the same rules that apply to changing the temperature set points also apply here).
- Press the “Settings” button to save the new alarm set point and exit this function, or after 5 seconds with no buttons pressed, the new alarm set point will be automatically saved.

### Hi temperature alarm

- If the cabinet temperature rises above the alarm set point for more than 5 minutes during operation, the display will begin to blink, and the “HIGH TEMP” LED will illuminate (blinking). This will continue until the temperature rises above the low temp set point or the low temp alarm set point is lowered.

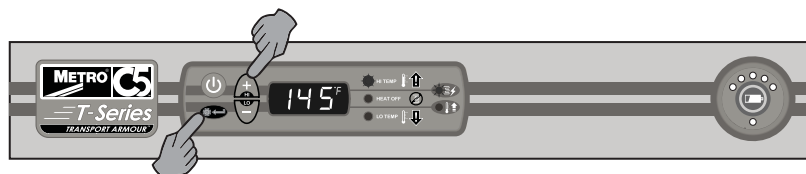

**NOTE:** This alarm is for ambient holding (HEAT OFF) applications. If the cabinet is operating in hot holding mode, this alarm is disabled.

**NOTE:** Audio (if enabled), Button press produces a 1/4 second “chirp”. Low temp Alarm: (3) 1/2 second beeps, repeating every 10 seconds.

### **Controller User Settings**

- User settings are classified as:  
*Temperature Scale Mode*  
*Sound Mode and*  
*Lock-out Mode*

#### **Modifying the Controller’s User Settings**

- Turn the cabinet OFF.
- Press and hold the “Settings” button. Press and release the “power” button. The display shows 3 horizontal bars (blinking).
- Continue holding the “Settings” button for 5 seconds. This enables the program mode, starting with temperature scale selection.

#### **Temperature scale mode**

- The display will show only the temperature scale (blinking). Press the “+ or –” button to toggle between °F and °C. Press the “Settings” button to save and advance to the Sound mode.

#### **Sound mode**

- The display shows “Snd On or Snd OFF” (blinking). Press the “+ or –” button to toggle between them (this setting will always default to the setting that it had previously been set to). Press the “Settings” button to save and advance to the Lockout mode.

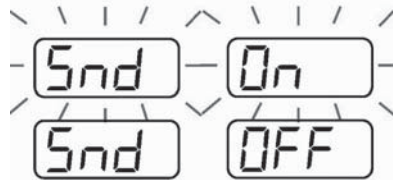

#### **Lock-out mode**

- The display shows “LOC On or LOC OFF” (blinking). Press the “+ or –” button to toggle between them (this setting will always default to the setting that it had previously been set to).
- Lock-out mode will prevent users from accidentally changing temperature and alarm settings. If the user attempts to change the settings of the cabinet while the control lock-out is enabled, the temperature display will show “LOC” (blinking) for 4 seconds before again displaying the current conditions.

**NOTE:** If no buttons are pressed for 20 seconds, the controller will automatically save and exit user settings mode.

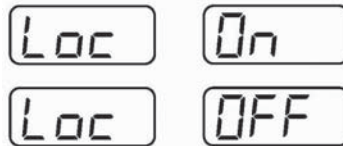

### **Service Diagnostic Codes**

- If the controller detects a problem in heating element, fan motor, or battery the following service codes will be displayed:

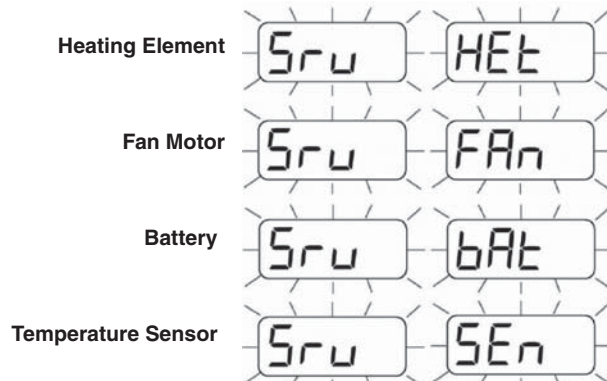

## OPERATING INSTRUCTIONS (ANALOG CONTROLLER)

- Analog cabinets are controlled by an ON/OFF power switch and adjustable thermostat(s).
- Indicator light near power switch glows when cabinet is turned on.
- Indicator light(s) near thermostat(s) glow when the cabinet heat element(s) are on to achieve or maintain cabinet temperature.
- Thermometer(s) read cabinet temperature(s) in both Fahrenheit (°F) and Centigrade (°C).
- The temperature range can be increased or decreased with “Thermostat Knob”.

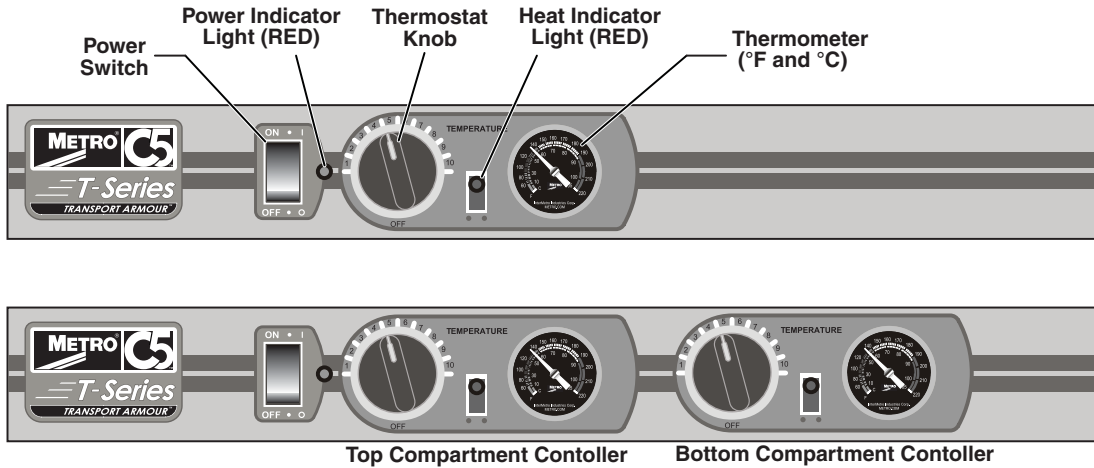

## HANDLING INSTRUCTIONS FOR TRANSPORTING CABINETS

- Always assure brakes are set in OFF position prior to moving cabinet.
- Assure door(s) is fully closed and travel latch (if equipped) is engaged.
- Push/Pull cabinets by the push / pull handles located on the back of the cabinet (not included on 1/2 ht models) or by the molded handles on front side of the armour panel.
- Always keep a firm grip on handles while cabinet is in motion.
- Ergonomic handles and bumpers are provided as grab points for easy handling while pushing, pulling and crossing thresholds, place your foot onto one of the bottom handles while pulling on the top handles (only pull enough to reduce the weight on the casters and to clear the obstacle).
- Arrange multiple cabinets close together (handle to handle) in transport vehicle.
- Never strap or band any cabinet over the top or the control panels as this may damage the electrical components.
- Apply brakes when cabinet is in transport vehicle.
- Strap/band cabinets across mid section and assure the straps are securely fastened to vehicle walls.
- When lowering on lift gate, apply caster brakes and pay attention that the cabinet does not move off the lift gate. Keep a firm grip on cabinet when lowering.



## CARE AND MAINTENANCE

### NOTICE

**Before proceeding with any maintenance activity strictly follow “Safety Information” on page 2 of this manual.**

### *Cleaning The Cabinet*

**WARNING:** Unplug the cabinet before cleaning or servicing. Do not wash the cabinet with a water jet or high pressure water.

**CAUTION:** Do not spray or pour water into the control enclosure. To clean the cabinet, wipe with a damp cloth and dry with a towel. Use only cleaning agents approved for stainless steel.

**CAUTION:** Do not use cleaners with chlorides or phosphates as they may cause damage to stainless steel.

1. Make certain that the cabinet has cooled down before cleaning. Use cleaners in the proper concentrations. Follow the manufacturer’s directions for the cleaning product used. The floor of the cabinet may be hosed out with low pressure water. After using any cleaning products, thoroughly rinse all surfaces to remove residue.
2. Use a damp cloth or sponge. Mild soap suitable for stainless steel is acceptable. Dry with a clean towel. Wipe up spills as soon as possible and regularly clean the cabinet to avoid staining and difficult to clean conditions.

### *Cabinet Maintenance — All Models*

C5 T-Series cabinets have been designed to require very little maintenance. With normal use, cleaning is the only form of maintenance that need to be done on a regular basis. Keeping the casters free of dirt build-up will go a long way in prolonging their life.

### NOTICE

**Regularly inspect the casters. Tighten loose fasteners and replace worn or damaged parts with new InterMetro approved parts. Replace worn or damaged casters immediately; lubricate casters regularly.**

### *Top Module Maintenance*

The module of the cabinet has also been designed to require very little maintenance. With normal use, cleaning is the only form of maintenance that needs to be done on a regular basis.

### *Battery Care (Digital Cabinet Only)*

- Keep the battery clean, dry and free of electrolyte and corrosion residue.
- Ensure wire connections and battery strap are tight.

## **BASIC TROUBLESHOOTING**

**WARNING:** Only factory approved service agents should attempt to service, repair or replace electrical components, wiring or power cord.

### **1. Controls do not work (no display or indicator lights):**

- Check that the cabinet is plugged-in.
- Check that the outlet has power.
- Check that the power switch is in the "On" position.
- Check the cabinet wiring from the power cord to the power switch and to the controller.
- Controller is faulty.

### **2. Controller temperature display does not change (displays a constant value approximately equal to the minimum or maximum of the set point temperature range, 85°F (29°C) or 200°F (93°C):**

- a. The temperature sensor and controller are not communicating:
  - Controller needs to be replaced.
  - Temperature sensor needs to be replaced.

### **3. Temperature too hot:**

- a. During initial pre-heat, cabinet may overshoot set point.
- b. If displayed temperature exceeds 220°F (104°C):
  - Blower wiring is faulty or disconnected. Blower needs replacing.
  - The thermostat may have failed and the thermal cut-out device is controlling the temperature.
  - Thermal cut-out device may have failed.
- c. Digital control: Refer to page 9 section - "High Temperature Alarm" for changing the set point temperature.

### **4. Temperature too low:**

- a. The cabinet may still be in pre-heat or recovering from the door being opened.
- b. Door(s) is not closed or sealing properly.
- c. Worn out door gaskets. Replace gaskets.
- d. Blower is not circulating air:
  - Blower wiring is faulty or disconnected.
- e. Refer to page 9 section - "low Temperature Alarm" for changing the set point temperature.

### **5. No heat generated**

- a. If the heat indicator light is on but the cabinet does not draw approximately 12 amps for 120V 1400W units and 8 amps for 220-240V 1176-1400W
  - Air heater element may be faulty.
  - The wiring to the air heater element may be faulty or disconnected.
  - The controller (air heater relay) may be faulty.
- b. If the heat indicator light does not come on, the controller may be faulty.

### **6. Display problems in cabinets:**

- Refer to page 10 section - "Service Diagnostic Codes".

# SERVICE AND REPLACEMENT PARTS

**WARNING:** Only factory approved service agents should attempt to service, repair or replace electrical components, wiring or power cord.

## Cabinet, Door and Electrical Parts

ITEM #	Replacement Part No.	Description	ITEM #	Replacement Part No.	Description
1	C5T-FS-5	1/2 HT CABINET FIXED SLIDES — 1 PR.	26	RP-WHITEBRD	WHITE BOARD WITH CLIPS
	C5T-FS-8	5/6 HT CABINET FIXED SLIDES — 1 PR.	27	RPC06-746	KNOB, ANALOG
	C5TD-FS-9	DUAL CAVITY CABINET FIXED SLIDES — 2 PR.	28	RPC13-083*	STRAIN RELIEF
	C5T-FS-9	TALL CABINET FIXED SLIDES — 1 PR.	29	RPC13-085*	WIRE JOINT, SET SCREW TYPE, ANALOG (NOT SHOWN)
2	C5T-SHELF	WIRE SHELF (MUST BE USED WITH RACK UPRIGHTS)	30	RPC13-096*	TERMINAL BLOCK
3A	RPC6P	6" CASTER, SWIVEL	31	RPC13-198	THERMAL CUT OUT
	RPC5P	5" CASTER, SWIVEL	32	RPC13-218	SGL CAVITY THERMOMETER, ANALOG
3B	RPC6PB	6" CASTER, BRAKE		RPC13-446	DUAL CAVITY THERMOMETER, ANALOG
	RPC5PB	5" CASTER, BRAKE	33	RPC13-234	SGL CAVITY THERMOSTAT, ANALOG
4	RPC06-1011A	TALL CABINET DOOR GASKET		RPC13-447	DUAL CAVITY THERMOSTAT, ANALOG
	RPC06-1011B	5/6 HT CABINET DOOR GASKET	34	RPC13-246	RED INDICATOR LIGHT, ANALOG CABINET
	RPC06-1011C	1/2 HT CABINET DOOR GASKET	35	RPC13-375	MASTER SWITCH, ANALOG CABINET
	RPC06-1011D	DUAL CAVITY DOOR GASKET	36	RPC13-440	125V 15A COIL POWER CORD, RT. ANGLE PLUG
5	RPC06-1039	SNAP BUSHING, .750"		RPC13-546	125V 15A COIL POWER CORD, STR. PLUG
6	RPC06-189	SNAP BUSHING, 1"		RPC13-537	250V 15A COIL POWER CORD, EXPORT
7	RPC07-055	BULB COVER GROMMET, DUAL CAVITY	37	RPC13-421	120V AC BLOWER, IMPELLER AND LH NUT — ANALOG
8	RPC11-446	REAR HANDLE		RPC13-509	220-240V AC BLOWER, IMPELLER AND NUT — EXPORT
9	RPC5T-5UPRT	1/2 HT CABINET RACK UPRIGHT — 1 PR.	38	RPC13-423	CONTROLLER, DIGITAL
	RPC5T-8UPRT	5/6 HT CABINET RACK UPRIGHT — 1 PR.	39	RPC13-424	BATTERY GAUGE, DIGITAL
	RPC5T-9DUPRT	DUAL CAVITY CABINET RACK UPRIGHT — 1 PR.	40	RPC13-438	MOTOR RELAY, DIGITAL
	RPC5T-9UPRT	TALL CABINET RACK UPRIGHT — 1 PR.	41	RPC5TD-SNR	DIGITAL TEMP SENSOR AND HARDWARE
10	RPC5T-ARMR-RD	MOLDED ARMOUR PANEL, RED WITH HARDWARE	42	RPC13-442	DUAL CAVITY WIRE HARNESS, DIGITAL
11	RPC5T-BMPR	STRIP BUMPER WITH INSERT AND SCREWS		RPC13-560	SGL CAVITY WIRE HARNESS, DIGITAL
12	C5T-BOTLD	BOTTOM LOAD SLIDE — 1 PR.	43	RPC13-451	120V 1350W, HEAT ELEMENT, SGL. CAVITY
13	RPC5T-CABPKT	CABINET DOOR POCKET		RPC13-510	240V 1350W, HEAT ELEMENT, EXPORT SGL. CAVITY
14	RPC5T-CRNL	TOP MOLDED CORNER	44	RPC13-501	120V 675W, HEAT ELEMENT, DUAL CAVITY
15	RPC5T-DRSTKR	DOOR STRIKE PLATE		RPC13-511	240V 675W, HEAT ELEMENT, EXPORT DUAL CAVITY
16	RPC5T-HDL	MOLDED HANDLE WITH HARDWARE	45	RPC13-503	24V DC MOTOR ASSY., DIGITAL
17	RPC5T-LPLD	LIP LOAD SLIDE — 1 PR.	46	RPC13-507	BATTERY, 12V DC
18	RPCORDCLIP	CORD CLIP WITH HARDWARE	47	RPC13-508	IMPELLER AND LH. NUT
19	RPC06-035	REAR HANDLE CAP	48	RPC13-519	CURRENT SENSOR, DIGITAL
20	RPC06-1032	INFO PANEL EXTRUSION	49	RPC13-521	POWER SUPPLY, DIGITAL
21	RPC14-329	DOOR LATCH	50	RPC13-557	FUSE HOLDER
22	RPC14-330	DOOR HINGE	51	RPC13-588	4A FUSE
23	RPC5T5-DOOR	1/2 HT CABINET COMPLETE DOOR ASSY.	52	RPC5-SCLP	ANALOG BULB CLAMP KIT
	RPC5T8-DOOR	5/6 HT CABINET COMPLETE DOOR ASSY.	53	RPC13-502	DC MOTOR CONTROLLER
	RPC5T9D-TOPDR	TOP DUAL CAVITY CABINET COMPLETE DOOR ASSY.	54	RPF07-125	UPRIGHT SPRING BUTTON CLIP
	RPC5T9D-BOTDR	BOT. DUAL CAVITY CABINET COMPLETE DOOR ASSY.	55	RPC5T-TRVL	TRAVEL LATCH/HSAP AND HARDWARE (NOT SHOWN)
	RPC5T9-DOOR	TALL CABINET COMPLETE DOOR ASSY.	56	C5TINFOLBL-10	INFO PANEL LABELS — 10 PK
24	RPC5T-INFO	COMPLETE INFO PANEL ASSY.			
25	RPF04-368	BINDING BARREL, DOOR LATCH			

**NOTE:** Some components are common to all cabinets. Certain items are common to both the single and dual cavity cabinets. Some electrical components are only used on dual cavity units. Refer to replacement parts list on page 14 and read the descriptions carefully to insure desired replacement part is ordered. To identify the cabinet model, see page 2.

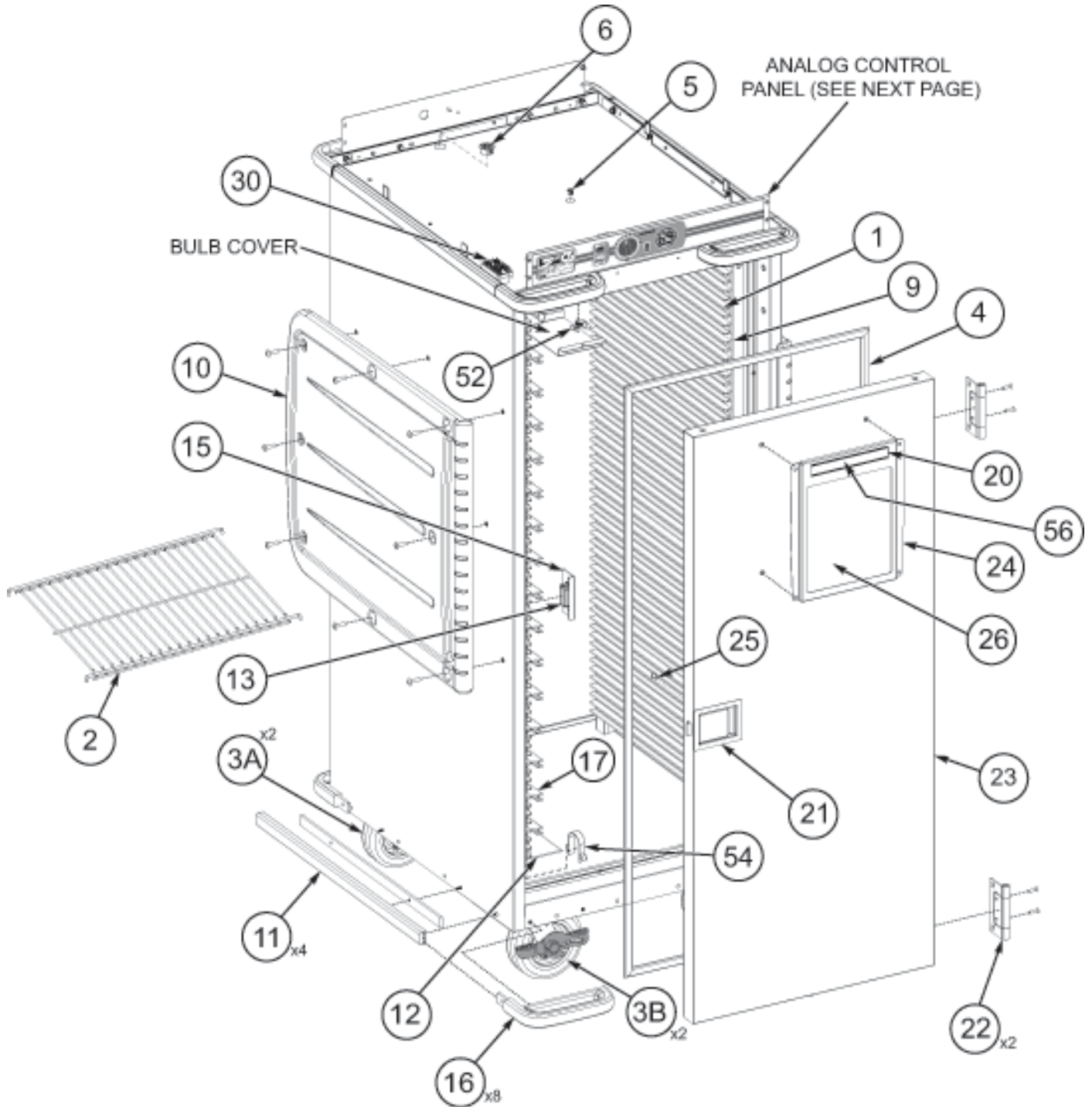

## ANALOG SINGLE CAVITY CABINET

(NOTE: TOP COVER REMOVED)

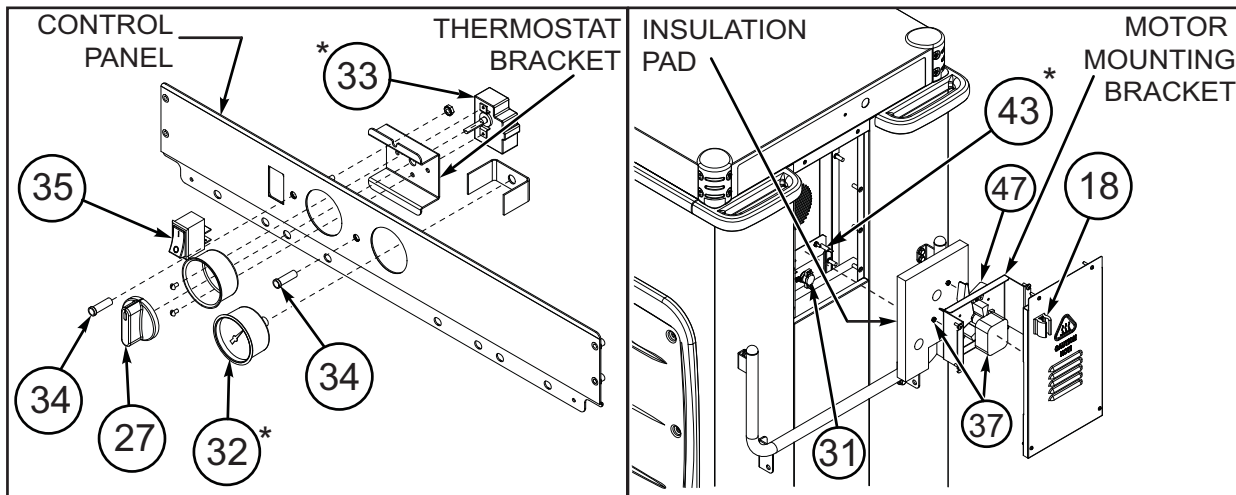
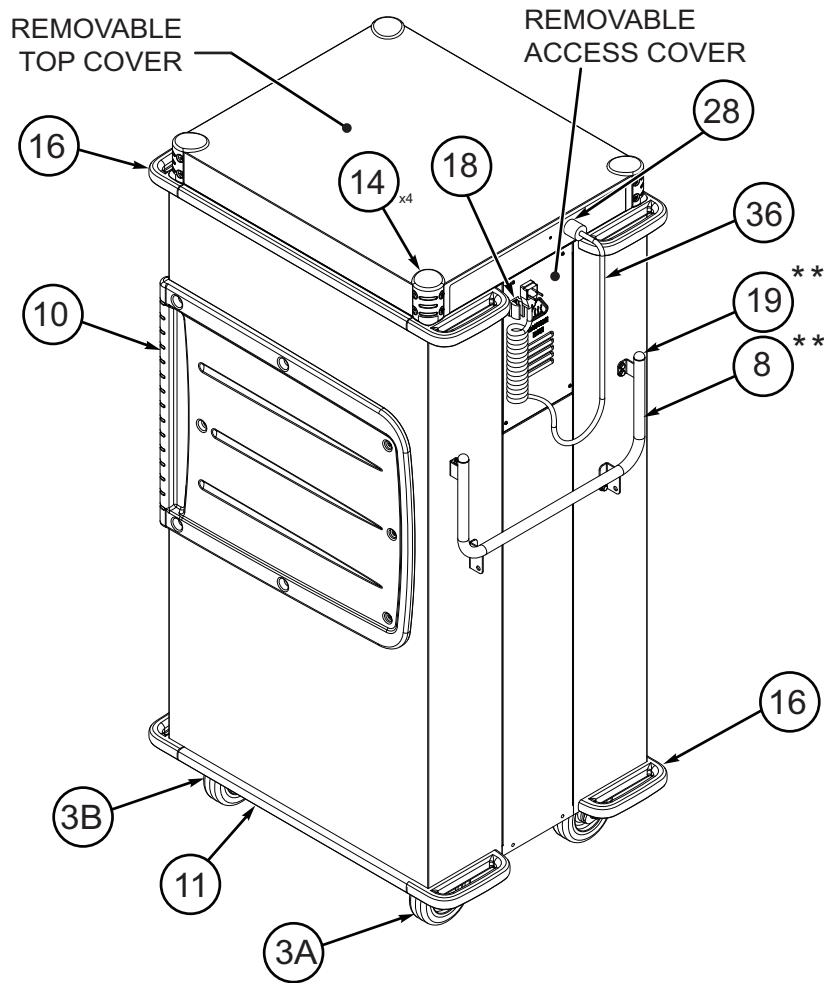

## ANALOG SINGLE CAVITY CABINET

\*\* ALL CABINETS EXCEPT 1/2 HT MODELS

\* SINGLE AND DUAL CAVITY CABINETS USE DIFFERENT ELECTRIC COMPONENTS. REFER TO REPLACEMENT PARTS LIST FOR DESIRED RP NUMBERS.





# Digital Dual Cavity Cabinet

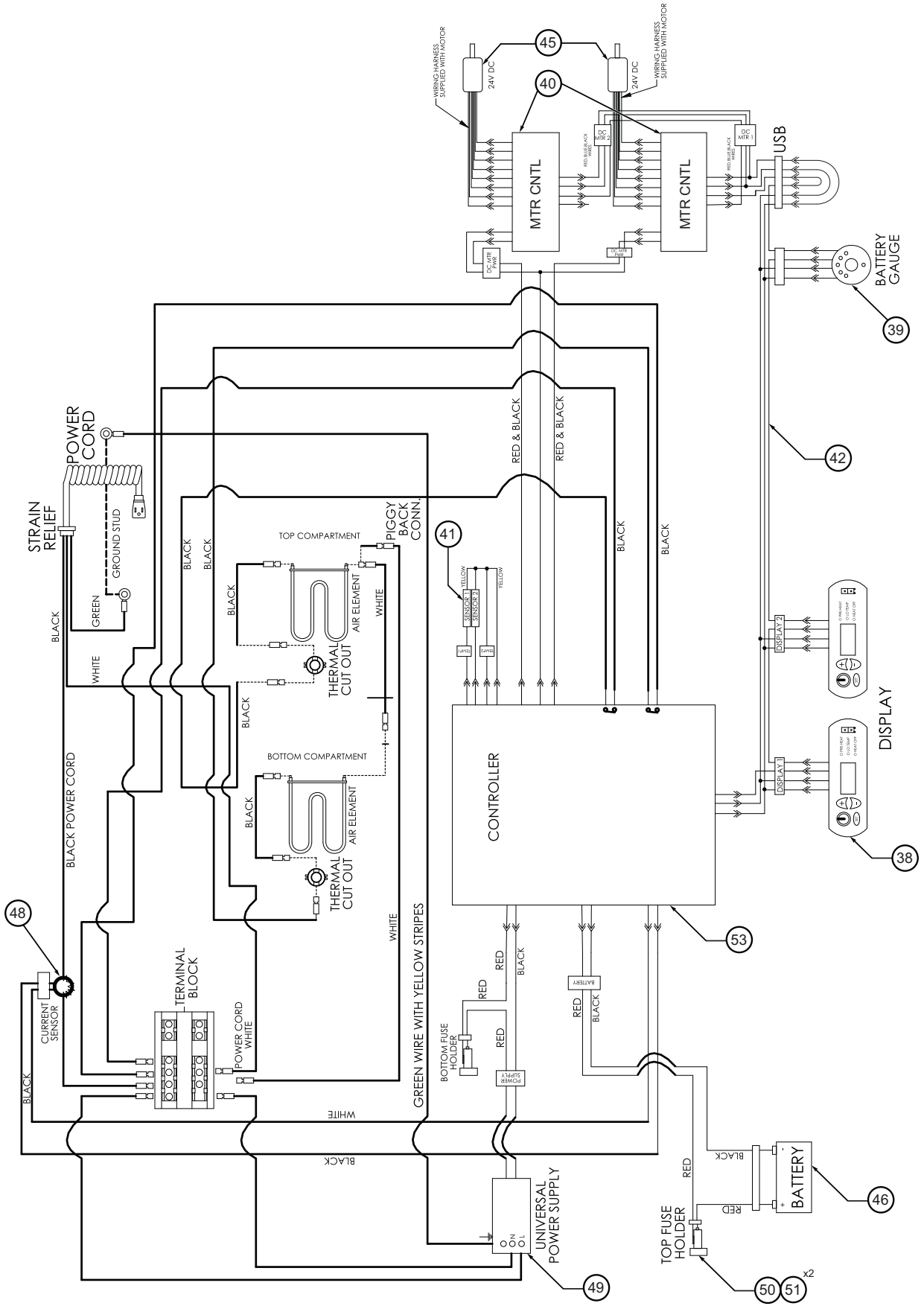



# Digital Single Cavity Cabinet

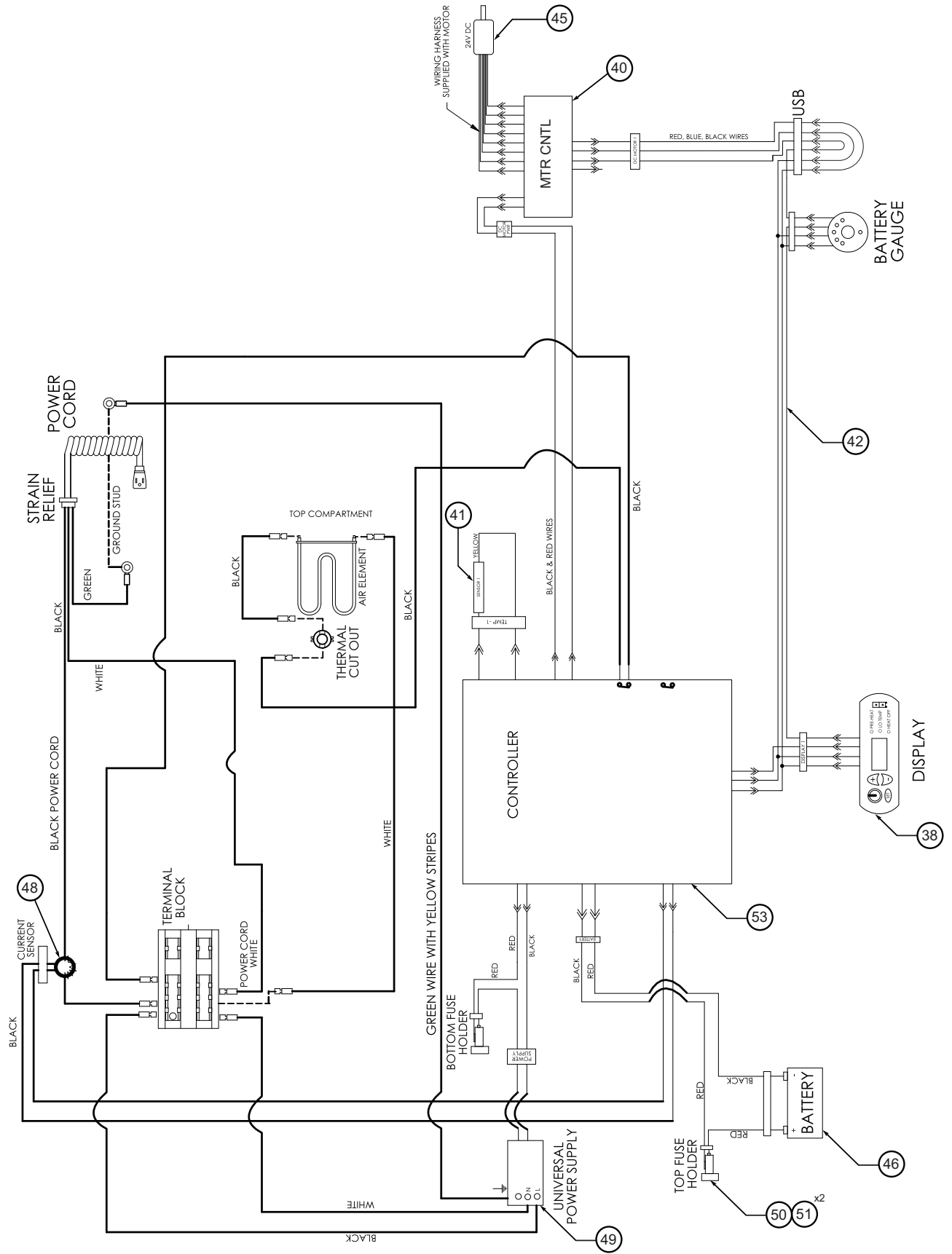

# Warranty

## WARRANTY, EXCLUSION OF WARRANTIES AND LIMITATION OF LIABILITY.

InterMetro Industries Corporation (hereinafter referred to as "Seller") warrants to the original purchaser that all products in its catalog, or custom products, delivered hereunder will be free from defects in workmanship and material. THE FOREGOING WARRANTY IS EXCLUSIVE AND IN LIEU OF ALL OTHER WARRANTIES, EXPRESS, IMPLIED OR STATUTORY, INCLUDING ANY WARRANTY OF MERCHANTABILITY OR FITNESS FOR A PARTICULAR PURPOSE. This Warranty shall be for a period of one (1) year from the date of shipment from Seller's warehouse or factory. If any product delivered hereunder does not meet the Warranty specified above, providing the product has not been altered in any way by anyone other than Seller's factory-authorized representative, and assuming normal and proper use and maintenance, Seller will, at its option, repair or replace any part or material it determines, upon inspection, to be defective; provided however, that a charge for labor will be made except during a period of one (1) year from the date of original shipment from Seller's warehouse or factory. No product, or part thereof, is to be returned to Seller without prior written approval from Seller's factory. All exchanges and replacement shipments will be F.O.B. Seller's factory. Warranties for equipment or articles not manufactured by the Seller are solely the warranties of the manufacturers thereof and they are hereby assigned to the purchaser without recourse to the Seller.

SELLER'S LIABILITY FOR ANY CLAIM OF ANY KIND, WHETHER BASED ON CONTRACT, NEGLIGENCE OR STRICT LIABILITY IN TORT, AND BY WHOMEVER MADE, FOR ANY DIRECT, INDIRECT, INCIDENTAL OR CONSEQUENTIAL LOSS, DAMAGE OR INJURY, RESULTING TO THE PURCHASER OR ANY THIRD PARTIES, arising out of, connected with or resulting from this Agreement, or from the performance or breach thereof, or from the manufacture, sale, delivery, resale, installation, inspection, repair or use of any product covered by or furnished under this Agreement, WHETHER OR NOT CAUSED BY SELLER'S NEGLIGENCE, SHALL IN ALL EVENTS BE EXCLUSIVELY LIMITED TO THE COST OF CORRECTING DEFECTIVE, DAMAGED OR NON-CONFORMING PARTS OR MATERIAL AS HEREIN PROVIDED, and upon the expiration of one (1) year, all such liability shall terminate.

SELLER DOES NOT AUTHORIZE any person to assume for it any obligations or liabilities greater than or different than those set forth in this Warranty. The terms under which any of Seller's products may be resold must be limited in accordance with this Warranty.

THIS AGREEMENT, and all the rights and obligations arising hereunder, shall be construed in accordance with, and be governed by, the law of the Commonwealth of Pennsylvania, U.S.A.

TO INSURE WARRANTY implementation, return the completed registration card within 15 days of cabinets' receipt to: InterMetro Industries Corp., Wilkes-Barre, PA 18705



InterMetro Industries Corporation  
Wilkes-Barre, PA 18705

Thank you for purchasing a Metro C5 T-Series Cabinet. We are certain you will be more than satisfied with its quality and performance. Please fill in the warranty information space below so we may register your warranty. Also, so that we may learn more about our customers and hopefully be of continued service in the future, please take a moment to fill in the customer information space below.

*Thank You*

**CUSTOMER INFORMATION**

1. Which one of the following best describes your establishment?

- a.  Full-Service Restaurant
- b.  Banquet Hall
- c.  Hotel/Motel
- d.  Hospital/Nursing Home
- e.  College/University
- f.  School
- g.  Employee Feeding
- h.  Other \_\_\_\_\_

**WARRANTY INFORMATION:**

Cabinet Model No. \_\_\_\_\_  
 Cabinet Serial No. \_\_\_\_\_  
 Date Purchased \_\_\_\_\_  
 Customer Name \_\_\_\_\_  
 Address \_\_\_\_\_  
 \_\_\_\_\_  
 Phone No. \_\_\_\_\_

For warranty coverage please fill out this card and return it to Metro, or go to [www.metro.com/heatedcabinetsupport](http://www.metro.com/heatedcabinetsupport) and select Online Warranty Registration to register electronically.

FOLD HERE — DO NOT DETACH

2. Please indicate the two product benefits that were of major interest to you.

- a.  Heavy Duty Construction
- b.  Easy-to-use controls
- c.  Foamed in Place Polyurethane Insulation
- d.  Transport Features (Handles, Bumpers)
- e.  Mobile Power System
- f.  Size Selection
- g.  Cabinet capacity
- h.  Slide selection
- i.  Easy-to-clean design
- j.  Other \_\_\_\_\_

3. Main factor that led to your decision to purchase this product?

- a.  Product operating and functional features
- b.  Overall quality
- c.  Price
- d.  Availability
- e.  Other \_\_\_\_\_

4. Three sources that led to the purchase of his product — in the order of their impact (1 — being most impact; 3 — being least impact).

- a.  Trade Journal Ad
- b.  Trade Show
- c.  Sales Call
- d.  Direct Mail
- e.  Previous Purchase
- f.  Other \_\_\_\_\_



WILKES-BARRE PA 18705-9968

P O BOX A

ATTN: CUSTOMER SERVICE

INTERMETRO INDUSTRIES CORPORATION

POSTAGE WILL BE PAID BY

BUSINESS REPLY MAIL  
FIRST-CLASS PERMIT NO. 121 WILKES-BARRE, PA

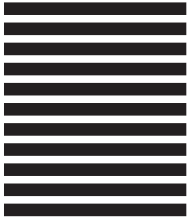

NO POSTAGE  
NECESSARY  
IF MAILED  
IN THE  
UNITED STATES



FOLD HERE — DO NOT DETACH

STAPLE HERE

STAPLE HERE

STAPLE HERE



**InterMetro Industries Corporation**  
North Washington Street, Wilkes-Barre, PA USA 18705  
For Product Information Call: 1-800-992-1776  
Visit Our Web Site: [www.metro.com](http://www.metro.com)

L01-459  
Rev. B • 9/12

Information and specifications are subject to change  
without notice. Please confirm at time of order.