



Installation Operation and Maintenance Instructions

Hazardous Location Models

MS24FASHRW Freezer

MS24RASHRW Refrigerator

MS24RFSHRW Combination Refrigerator /
Freezer



CONTENTS

Unpacking your refrigerator	3
Removing the packaging	3
Warranty registration	3
Installing your refrigerator	4
Select location	4
Installation	4
Cabinet clearances	4
Leveling legs	4
Electrical Connection	4
Wiring	4
Sealing	4
Handle installation	5
Door alignment	5
Dimensions for 4EAF, 6EAR, 6ERF	6
Rough in opening dimensions for 4EAF, 6EAR, 6ERF	6
Adjusting the temperature control.....	7
Defrosting instructions	7
Energy Saving Tips	7
Care and Cleaning	8
Trouble shooting your refrigerator	9
Obtaining service	10
Commercial product warranty	11

Important Safety Instructions

Warnings and safety instructions appearing in this guide are not meant to cover all possible conditions and situations that may occur. Common sense, caution, and care must be exercised when installing, maintaining, or operating this appliance.

Recognize Safety Symbols, Words, and Labels.

CAUTION

CAUTION—Hazards or unsafe practices which could result in personal injury or property or product damage.

WARNING

WARNING—Hazards or unsafe practices which could result in personal injury.

NOTE

NOTE—Important information to make a problem free installation.

UNPACKING YOUR REFRIGERATOR

Remove Packaging

Your refrigerator has been packed for shipment with all parts that could be damaged by movement securely fastened. Cut the banding material at the bottom of the carton, unfold the carton at the bottom and remove the carton from the appliance. Remove the plastic bag, styrofoam corner posts, and any tape holding the door closed and internal components in place. The owners manual is shipped inside the refrigerator in a plastic bag along with the warranty registration card.

Important

Keep your carton packaging until your refrigerator has been thoroughly inspected and found to be in good condition. If there is damage, the packaging will be needed as proof of damage in transit. Afterwards please dispose of all items responsibly in particular the plastic bags which can be a suffocation hazard.

Note to Customer

This merchandise was carefully packed and thoroughly inspected before leaving our plant. Responsibility for its safe delivery was assumed by the retailer upon acceptance of the shipment. Claims for loss or damage sustained in transit must be made to the retailer.

DO NOT RETURN DAMAGED MERCHANDISE TO THE MANUFACTURER - FILE THE CLAIM WITH THE RETAILER.

NOTE

If the unit was shipped or has been laying on its back for any period of time allow the refrigerator to sit upright for a period of at least 24 hours before plugging in. This will assure oil returns to the compressor. Plugging the refrigerator in immediately may cause damage to internal parts.

Warranty Registration

It is important you send in your warranty registration card immediately after taking delivery of your refrigerator or you can register online at www.marvelrefrigeration.com.

The following information will be required when registering your unit.

Model Number
Serial Number
Date of Purchase
Dealer's name and address

The model number and serial number can be found on the serial plate which is located inside the cabinet on the left side near the top.

CAUTION

Help Prevent Tragedies

Child entrapment and suffocation are not problems of the past. Junked or abandoned refrigerators are still dangerous, even if they sit out for "just a few days".

If you are getting rid of your old refrigerator, please follow the instructions below to help prevent accidents.

Before you throw away your old refrigerator or freezer:

- Take off the doors or remove the drawers.
- Leave the shelves in place so children may not easily climb inside.

INSTALLING YOUR REFRIGERATOR

These refrigerators and freezers have been engineered for institutional and industrial hazardous locations and meet Underwriters Laboratories specifications for Class 1 Groups C and D. Approved by the New York City Board of Standards and Appeals under Calendar Number 496-80-SA.

Select Location

The proper location will ensure peak performance of your appliance. Choose a location where the unit will be out of direct sunlight and away from heat sources.

The condenser is mounted on the back of the cabinet so the unit cannot be built in. At least 1-1/2 inches (3.8cm) of clearance from the back wall is required for proper ventilation.

Installation

The 4.5 and 6.1 cu. ft. refrigerators are designed for recessed as well as freestanding installation.

To recess the 4.5 and 6.1 cu. ft. models make the opening 25-7/8" (657.4mm) wide x 35-3/4" (908.1mm) high x 27-1/2" (698.5mm) deep with ample provision for wiring as described in the following paragraph "Sealing" instructions. Other service information can be found on pages 8 and 9. Provisions should be made to easily remove the unit for servicing.

Do not back the unit up to heat ducts or hot water lines.

Cabinet Clearance

Ventilation is required from the bottom front section of the unit. Keep this area open and clear of any obstructions.

Leveling Legs

Adjustable legs at the front and rear corners of the unit should be set so the unit is firmly positioned on the floor and level from side to side and front to back. Turn leveling legs clockwise to raise unit, counterclockwise to lower it. (See Figure 1).

Electrical Connection

Check serial plate for correct power supply. Use only electrical power supply as specified on your appliance serial plate.

Wiring

Hazardous location models are not supplied with power cords or plugs. All wiring methods must comply with the latest National Electrical Code, Article 501-4 for Class 1, Divisions 1 and 2.

Sealing

Article 501-5 of the National Electrical Code Class 1, Division 1 requires that in Class 1 Division 1 locations, seals shall be located as follows:

In each conduit run entering an enclosure for switches, circuit breakers, fuses, relays, resistors, or other apparatus which may produce arcs, sparks, or high temperatures, seals shall be placed as close as practicable and in no case more than 18" (45.7cm) for such enclosures.

CAUTION

Front Grille

Do not obstruct the front grill. The openings within the front grill allow air to flow through the condenser heat exchanger. Restrictions to this air flow will result in increased energy usage and loss of cooling capacity. For this reason it is important this area to not be obstructed and the grill openings kept clean. Marvel does not recommend the use of custom made grills as air flow may be restricted because of inadequate openings. (See Figure 1).

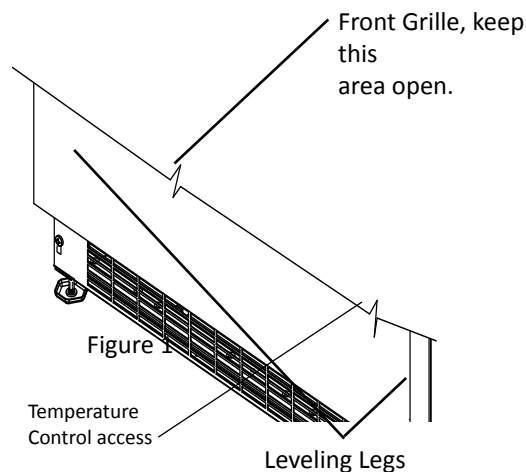

HANDLE INSTALLATION

Handle Installation

1. Remove the handle, (2) screws, and 5/32" hex key wrench from the bag shipped inside the cabinet.
2. Locate handle opposite the hinges and secure in place using the (2) screws and the hex key wrench.
(See Figure 2).

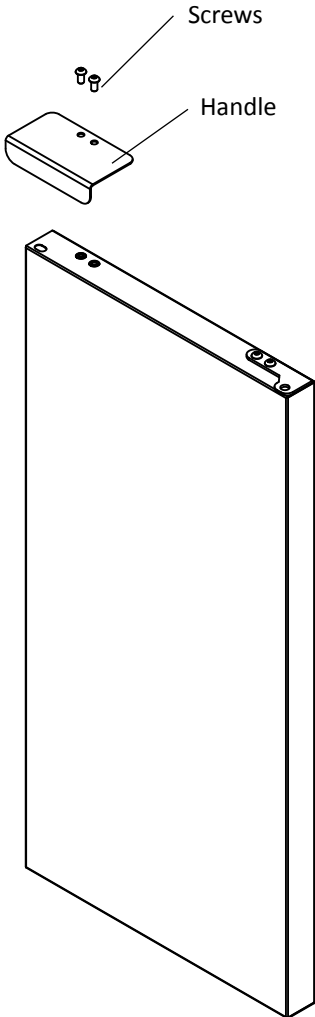

Figure 2
Right hand hinged
door shown

Step 1: Verify door alignment

The door should be parallel to the sides and top of the refrigerator. If alignment is necessary the door may be adjusted by loosening the 2 screws which secure the hinge adapter brackets on the top and bottom of the door and adjusting the door side to side. Use a 5/32" allen wrench for this procedure. (See Figure 3 below). When finished aligning the door, tighten the screws securely.

NOTE

For the door to close properly, it is necessary to maintain a minimum space of 9/32" (7.1mm) between the door and cabinet flange (See Figure 3). This space can be adjusted by adjusting the top and bottom hinge adapter brackets.

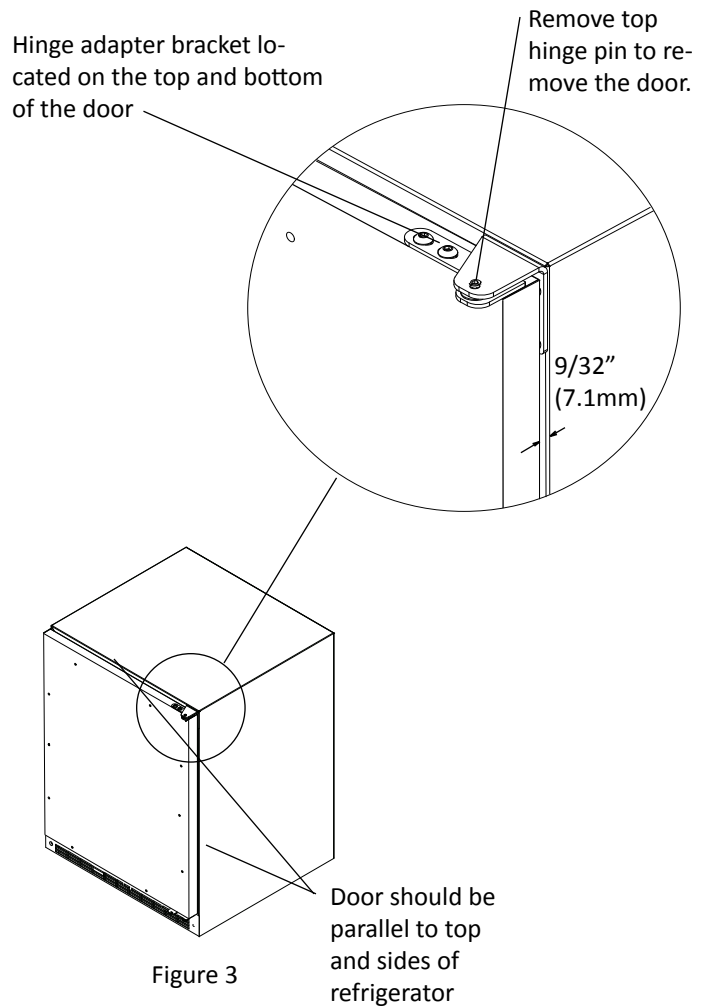
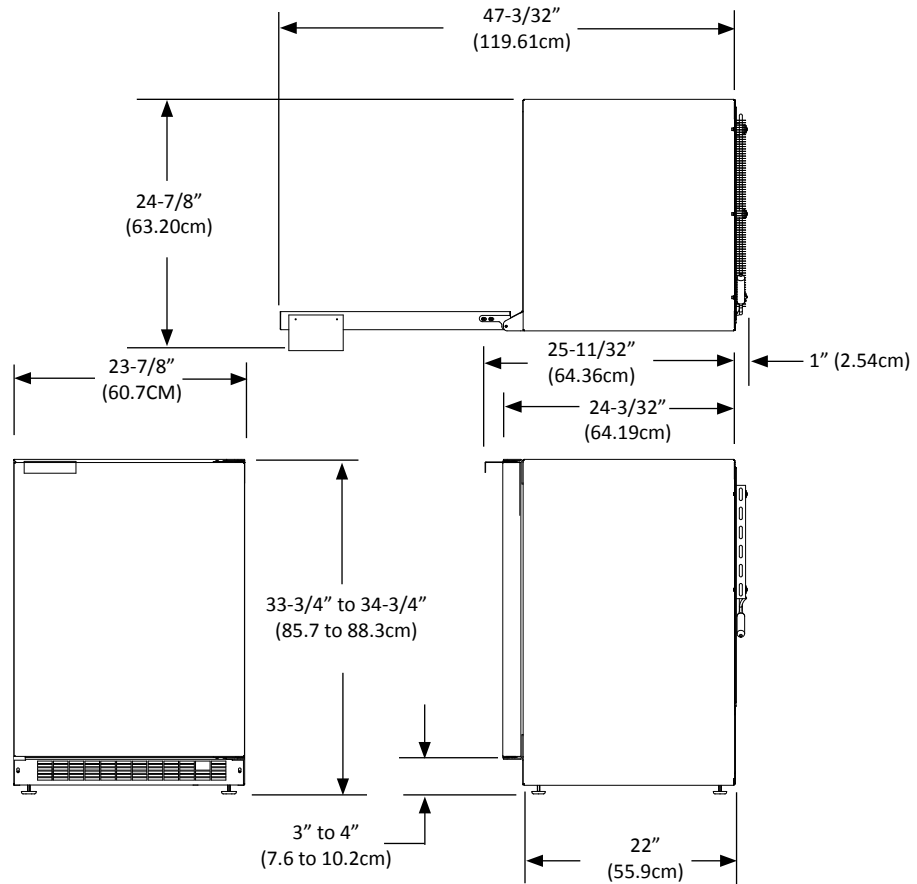
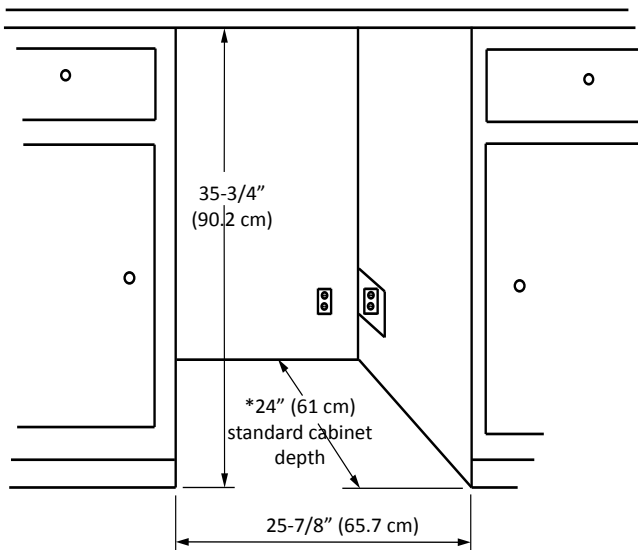

Figure 3

DIMENSIONS FOR 4EAF, 6EAR, 6ERF WITH SOLID DOOR



ROUGH IN OPENING FOR 4EAF, 6EAR, 6ERF WITH SOLID DOOR



* Depth dimension may vary depending on each individual installation. A minimum depth of 27-1/2" (69.9cm) is required with ample provision for wiring.

ADJUSTING THE TEMPERATURE CONTROL

Adjusting the temperature control

The temperature control shaft is located behind the front grill on the right side of the cabinet. (See Figure 1, on page 4). It can be adjusted with a flat bladed screwdriver.

Initially set the control midway between the turning ranges. Then adjust to the temperature that suits your application. The more the shaft is turned clockwise, the cooler the temperature. To turn off the refrigeration system turn the shaft counterclockwise until it stops.

Defrosting Instructions

Model 6EAR (all-refrigerator) automatically defrosts its cooling plate during each compressor off cycle. No manual defrosting is required.

The combination refrigerator / freezer (6ERF) and the freezer (4EAF) are manual defrost models and require occasional defrosting. Never use a scraper or any tool that might scratch or pierce the cooling plate. Follow these steps whenever 1/4 inch or more of frost accumulates.

1. Set the temperature control to the "OFF" position by turning the temperature control shaft counterclockwise until it stops. This will turn off the refrigeration system.
2. Remove the contents from the unit.
3. Place pans of hot water on the cooling plate if you wish to speed up defrosting.
4. Wipe out the interior and replace the contents.
5. Set the temperature control to the desired level.

In the Event of a Power Failure

Minimize the number of door openings to prevent a gradual rise in temperature while the power is off.

NOTE: If a power interruption occurs, the unit may take five (5) to ten (10) minutes to restart.

Energy Saving Tips

The following suggestions will minimize the cost of operating your refrigeration appliance.

1. Do not install your appliance next to a hot appliance, (cooker, dishwasher, etc.), heating air duct, or other heat sources.
2. Install product out of direct sunlight.
3. Assure the toe grille vents at front of unit beneath door are not obstructed and kept clean to allow ventilation for the refrigeration system to expel heat.
4. Plug your appliance into a dedicated power circuit. (Not shared with other appliances).
5. When initially loading your new product, or whenever large quantities of warm contents are placed within refrigerated storage compartment, minimize door openings for the next 12 hours to allow contents to pull down to compartment set-point temperature.
6. Maintaining a relatively full storage compartment will require less appliance run time than an empty compartment.
7. Assure door closing is not obstructed by contents stored in your appliance.
8. Allow hot items to reach room temperature before placing in product.
9. Minimize door openings and duration of door openings.
10. Use the warmest temperature control set-point that meets your personal preference and provides the proper storage for your stored contents.
11. For wine storage products:
 - a. When serving temperatures are not required, return the compartment(s) set-point to the ideal red and white wine long term storage temperature of 13°C / 55°F.
 - b. For Dual-Zone product with two (2) independent temperature controlled compartments, use the lower compartment for the coldest storage / serving temperature, (i.e.- red wines on top, white wines in lower).
12. Minimize use of display lighting option on glass door products, (light stays on with door closed).
13. When on vacation or away from home for extended periods, set the appliance to warmest acceptable temperature for the stored contents.
14. Set the control to the "off" position if cleaning the unit requires the door to be open for an extended period of time.
- 15) Annually clean condenser heat exchange coil located on the back of the unit. See page 8.

CARE AND CLEANING

Cleaning instructions

Condenser

The condenser tubing or fins behind the cabinet do not require frequent cleaning; however, satisfactory cooling depends on adequate ventilation over the condenser. Be sure that nothing obstructs the air flow openings in the front grill (see Figure 1). At least once or twice a year brush or vacuum the condenser for efficient performance.

CAUTION

Use care when cleaning the condenser. The condenser fins are sharp and could cause cuts.

Cabinet

The painted cabinet can be washed with mild soap and water and thoroughly rinsed with clear water. NEVER use abrasive scouring cleaners.

Interior

Wash interior compartment with mild soap and water. DO NOT use an abrasive cleaner, solvent, polish cleaner, or undiluted detergent.

Door Gasket

The vinyl gasket may be cleaned with mild soap and water, a baking soda solution, or a mild scouring powder.

TROUBLESHOOTING YOUR REFRIGERATOR

Before You Call for Service

If the unit appears to be malfunctioning, read through this manual first. If the problem persists, check the troubleshooting guide below. Locate the problem in the guide and refer to the cause and its remedy before calling for service. The problem may be something very simple that can be solved without a service call. However, it may be required to contact your dealer or a qualified service technician.

WARNING

Electrocution Hazard - Never attempt to repair or perform maintenance on the unit until the main electrical power has been disconnected. Turning the unit control "OFF" does not remove electrical power from the units wiring.

Problem	Possible Cause	Remedy
Unit not cold enough.	<ul style="list-style-type: none">• Control set too warm.• Airflow to front grille blocked.• Excessive usage or prolonged door openings.• Door gasket not sealing properly.	<ul style="list-style-type: none">• Adjust temperature colder. See page 7 for adjusting thermostat. Allow 24 hours for temperature to stabilize.• Airflow must not be obstructed to front grille. See "clearances" on page 4.• Allow temperature to stabilize for at least 24 hours.• Check door alignment and/or adjust or replace door gasket.
Unit too cold.	<ul style="list-style-type: none">• Control set too cold.	<ul style="list-style-type: none">• Adjust temperature warmer. See page 7 for adjusting thermostat. Allow 24 hours for temperature to stabilize.
Noise or Vibration.	<ul style="list-style-type: none">• Unit not level.	<ul style="list-style-type: none">• Level unit, see "Leveling Legs" on page 4.
Unit will not run.	<ul style="list-style-type: none">• No power to unit.	<ul style="list-style-type: none">• Circuit breaker tripped, reset circuit breaker.

OBTAINING SERVICE

If Service is Required:

- If the product is within the first year warranty period please contact your dealer or call Marvel Customer Service at 800.223.3900 for directions on how to obtain warranty coverage in your area.
- If the product is outside the first year warranty period, Marvel Customer Service can provide recommendations of service centers in your area. A listing of authorized service centers is also available at www.marvelrefrigeration.com under the service and support section.
- In all correspondence regarding service, be sure to give the model number, serial number, and proof of purchase.
- Try to have information or description of nature of the problem, how long the unit has been running, the room temperature, and any additional information that may be helpful in quickly solving the problem.
- Table A is provided for recording pertinent information regarding your product for future reference.

For Your Records	
Date of Purchase	
Dealer's name	
Dealer's Address	
Dealer's City	
Dealer's State	
Dealer's Zip Code	
Appliance Serial Number	
Appliance Model Number	
Date Warranty Card Sent (Must be within 10 days of purchase).	

Table A

COMMERCIAL PRODUCT WARRANTY

Marvel Refrigeration (Marvel) Limited Warranty

ONE YEAR LIMITED PARTS & LABOR WARRANTY

For one year from the date of original purchase, this warranty covers all parts and labor to repair or replace any part of the product that proves to be defective in materials or workmanship. For products installed and used for normal residential use, material cosmetic defects are included in this warranty, with coverage limited to 60 days from the date of original purchase. All service provided by Marvel under the above warranty must be performed by a Marvel factory authorized servicer, unless otherwise specified by Marvel. Service provided during normal business hours.

TWO YEAR LIMITED PARTS & LABOR WARRANTY (MARVEL PROFESSIONAL PRODUCTS)

For two years from the date of original purchase, this warranty covers all parts and labor to repair or replace any part of the product that proves to be defective in materials or workmanship. For products installed and used for normal residential use, material cosmetic defects are included in this warranty, with coverage limited to 60 days from the date of original purchase. All service provided by Marvel under the above warranty must be performed by a Marvel factory authorized servicer, unless otherwise specified by Marvel. Service provided during normal business hours.

AVAILABLE THIRD YEAR LIMITED WARRANTY (MARVEL PROFESSIONAL PRODUCTS)

For designated Marvel Professional product, Marvel offers a one year extension of the two year warranty coverage from the date of purchase, free of charge. To take advantage of this third year warranty, you must register your product with Marvel within 60 days from the date of purchase at marvelrefrigeration.com and provide proof of purchase.

LIMITED FIVE YEAR SEALED SYSTEM WARRANTY

For five years from the date of original purchase, Marvel will repair or replace the following parts, labor not included, that prove to be defective in materials or workmanship: compressor, condenser, evaporator, drier, and all connecting tubing. All service provided by Marvel under the above warranty must be performed by a Marvel factory authorized servicer, unless otherwise specified by Marvel. Service provided during normal business hours.

WARRANTY TERMS

These warranties apply only to products installed in any one of the fifty states of the United States, the District of Columbia, or the ten provinces of Canada. The warranties do not cover any parts or labor to correct any defect caused by negligence, accident or improper use, maintenance, installation, service, repair, acts of God, fire, flood or other natural disasters. The product must be installed, operated, and maintained in accordance with the Marvel User Guide.

The remedies described above for each warranty are the only ones that Marvel will provide, either under these warranties or under any warranty arising by operation of law. Marvel will not be responsible for any consequential or incidental damages arising from the breach of these warranties or any other warranty, whether express, implied, or statutory. Some states do not allow the exclusion or limitation of incidental or consequential damages, so the above limitation or exclusion may not apply to you. These warranties give you specific legal rights, and you may also have other rights which vary from state to state.

Any warranty that may be implied in connection with your purchase or use of the product, including any warranty of merchantability or any warranty fit for a particular purpose is limited to the duration of these warranties, and only extends to five years in duration for the parts described in the section related to the five year limited warranty above. Some states do not allow limitations on how long an implied warranty lasts, so the above limitations may not apply to you.

- The warranties only apply to the original purchaser and are non-transferable.
- These warranties cover products installed and used for normal residential use only.
- The warranties apply to units operated outside only if designed for outdoor use by model and serial number.
- Replacement water filters, light bulbs, and other consumable parts are not covered by these warranties.
- The start of Marvel's obligation is limited to four years after the shipment date from Marvel.
- In-home instruction on how to use your product is not covered by these warranties.
- Food, beverage, and medicine loss are not covered by these warranties.
- If the product is located in an area where Marvel factory authorized service is not available, you may be responsible for a trip charge or you may be required to bring the product to a Marvel factory authorized service location at your own cost and expense.
- Units purchased after use as floor displays, and/or certified reconditioned units, are covered by the limited one year warranty only and no coverage is provided for cosmetic defects.
- Signal issues related to Wi-Fi connectivity are not covered by these warranties.

For parts and service assistance, or to find Marvel factory authorized service near you, contact Marvel Refrigeration:

MarvelRefrigeration.com • techsupport@MarvelRefrigeration.com • +616.754.5601
1260 E. Van Deine St., Greenville, MI 48838



www.marvelrefrigeration.com

Marvel Refrigeration

1260 E. VanDeinse St.
Greenville MI 48838

800.223.3900

41004297 Rev K
1/14/20

All specifications and product designs subject to change without notice. Such revisions do not entitle the buyer to corresponding changes, improvements, additions, replacements or compensation for previously purchased products.