

Installation Manual

NPE Condensing Water Heaters

Model	NPE-180A
	NPE-210A
	NPE-240A
	NPE-150S
	NPE-180S
	NPE-210S
	NPE-240S



* Lead Free

Keep this manual near this water heater for future reference whenever maintenance or service is required.

* The wetted surface of this product contacted by consumable water contains less than one quarter of one percent (0.25%) of lead by weight.



WARNING

If the information in these instructions is not followed exactly, a fire or explosion may result, causing property damage, personal injury or death.

Do not store or use gasoline or other flammable vapors and liquids in the vicinity of this or any other appliance.

What to do if you smell gas

- Do not try to light any appliance.
- Do not touch any electrical switch; do not use any phone in your building.
- Immediately call your gas supplier from a neighbor's phone. Follow the gas supplier's instructions.
- If you cannot reach your gas supplier, call the fire department.

Installation and service must be performed by a qualified installer, service agency or the gas supplier.

The installation must conform with local codes or, in the absence of local codes, the National Fuel Gas Code, ANSI Z223.1/NFPA 54 and/or CSA B149.1, Natural Gas and Propane Installation Code.

When applicable, the installation must conform with the Manufactured Home Construction and Safety Standard, Title 24 CFR, Part 3280 and/or CAN/CSA Z240 MH Series, Mobile Homes.

Contents

1. Safety Information	3	6. Appendixes	54
2. About the Water Heater	5	6.1 Gas Conversion	54
2.1 Items Included	5	6.2 Technical Data	60
2.2 Accessories	5	6.3 Wiring Diagram	63
2.3 Specifications	6	6.4 Ladder Diagram	65
2.5 Components	8	6.5 Component Assembly Diagrams and Parts Lists	67
2.6 Dimensions	11	6.6 Installation Check list	79
2.7 Rating Plate	13	6.7 Navien H2Air Add-on Controller Kit (Optional)	81
3. Installing the Water Heater	14	6.8 Navien HotButton Kit (Optional)	82
3.1 Choosing an Installation Location	14	6.9 Requirements for the State of Massachusetts	83
3.2 Mounting the Water Heater to the Wall	15		
3.3 Connecting the Gas Supply	16		
3.4 Connecting the Water Supply	20		
3.5 Connecting the Condensate Drain	26		
3.6 Venting the Water Heater	29		
3.7 Connecting the Power Supply	37		
3.8 Setting the DIP Switches	37		
4. Installing a Cascade System	39		
4.1 Connecting Water Supplies	39		
4.2 Connecting the Communication Cables	40		
5. Installing a Common Vent System	42		
About the Common Vent System	42		
Navien Backflow Damper (Back-draft Damper)	46		
Starting the Common Vent System	47		
Connecting and Terminating the Vent Pipe	49		
Setting Up the Common Vent System	50		
Common Vent Termination Clearances	51		
Exhaust Vent Termination Clearances (For Direct Vent)	52		
Maintenance	53		

1. Safety Information

The following safety symbols are used in this manual. Read and follow all safety instructions in this manual precisely to avoid unsafe operating conditions, fire, explosion, property damage, personal injury, or death.

DANGER

Indicates an imminently hazardous situation which, if not avoided, could result in severe injury or death.

WARNING

Indicates a potentially hazardous situation which, if not avoided, could result in injury or death.

CAUTION

Indicates a potentially hazardous situation which, if not avoided, could result in property damage.

DANGER

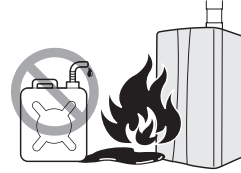

If you smell gas:

- Do not try to light any appliance.
- Do not touch any electrical switches or use landline phones.
- From a neighbor's phone, call your gas provider and follow their instructions.
- If you cannot reach your gas provider, call the fire department.

Do not use or store flammable products, such as gasoline, solvents, or adhesives in the same room or area as the water heater.

- The water heater has a main burner flame that can turn on at any time and can ignite flammable vapors. Vapors from flammable liquids can explode and catch fire, causing death or severe burns.
- Vapors cannot be seen and are heavier than air. They can travel long distances along the ground and can be carried from other rooms to the water heater's main burner flame by air current.
- Keep all flammable products far away from the water heater and store them in approved containers. Keep the containers closed tightly and out of the reach of children and pets.



WARNING

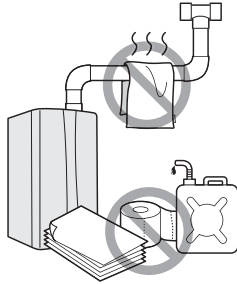

- **Do not store or use gasoline or other flammable liquids near this water heater.**
Doing so may result in fire or explosion.
- **Do not place combustibles, such as newspapers or laundry, near the water heater or venting system.**
Doing so may result in a fire.
- **Do not place or use hair sprays, spray paints, or any other compressed gases near the water heater or venting system, including the vent termination.**
Doing so may result in fire or explosion.
- **Do not remove the front cover unless the power to the water heater is turned off or disconnected.**
Failure to do so may result in electric shock.
- **Do not operate the water heater with the front cover opened.**
Doing so may result in fire or carbon monoxide (CO) poisoning, which may result in property damage, personal injury, or death.
- **Do not operate this water heater without proper venting.**
Doing so may result in fire or carbon monoxide (CO) poisoning, which may result in property damage, personal injury, or death.
- **Do not touch the power cord or internal components of the water heater with wet hands.**
Doing so may result in electric shock.







CAUTION

- **Do not turn on the water heater unless the water and gas supplies are fully opened.**
Doing so may damage the water heater.
- **Do not turn on the water if the cold water supply shut-off valve is closed.**
Doing so may damage the water heater.
- **Do not use this water heater for anything other than its intended purpose, as described in this manual.**
- **When servicing the controls, label all wires prior to disconnecting them.**
Failure to do so may result in wiring errors, which can lead to improper or dangerous operation. Verify proper operation after servicing.
- **Do not use unapproved replacement or accessory parts.**
Doing so may result in improper or dangerous operation and will void the manufacturer's warranty.
- **Do not place anything in or around the vent terminals, such as a clothes line, that could obstruct the air flow in or out of the water heater.**
- **This water heater has been approved for use in the USA and Canada only.**
Using the water heater in any other country will void the manufacturer's warranty.

2. About the Water Heater



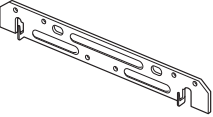
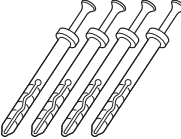
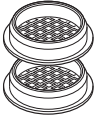
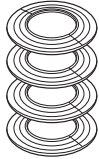

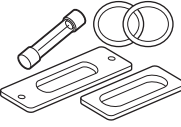
2.1 Items Included

When you open the box, you will find the following items with the water heater. Check the box for each of the following items before installing the water heater.

	
Installation & Operation Manual	Quick Installation Manual
	
Wall Mounting Bracket	Tapping Screws & Anchors
	
2 in Vent Termination Caps	2 in Wall Flanges
	
Conversion Kit	Spare Parts

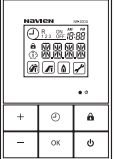
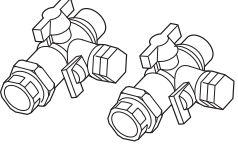
2.2 Accessories

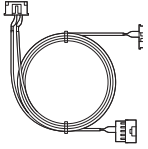
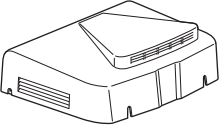
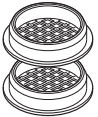
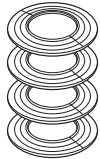
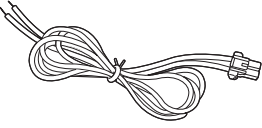
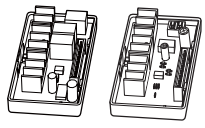
The following optional accessories are available for the water heater:

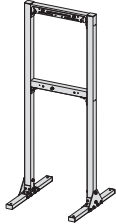
	
Remote Controller	Plumb Easy Valve Set
	
Pressure Relief Valve	Condensate Neutralizer
	
Ready-Link Communication Cable	Outdoor Vent Kit
	
3 in Vent Termination Caps	3 in Wall Flanges
	
External Pump Connector (<150W,1.5A)	Navien HotButton Kit / H2Air Add-on Controller Kit
	
Navi-Link (Wi-Fi Control System)	Ready-Link Rack

2.3 Specifications

The following table lists the specifications for the water heater. Additional specifications about water, gas, electric, and air supplies (venting) appear in the Installation section.

Item		NPE-150S	NPE-180(A)	NPE-180S	NPE-210(A)	NPE-210S	NPE-240(A)	NPE-240S
Heat Capacity (Input)	Natural Gas	18,000-120,000 BTU/H	15,000-150,000 BTU/H		19,900-180,000 BTU/H		19,900-199,900 BTU/H	
	Propane Gas		15,000-150,000 BTU/H		19,900-180,000 BTU/H		19,900-199,900 BTU/H	
Energy Factor	UEF (for NG & LP)	0.96	0.96	0.97	0.96	0.97	0.96	0.97
	EF (Canada) (for NG & LP)	0.97	0.97	0.99	0.97	0.99	0.97	0.99
Flow Rate (DHW)	35 °F (19 °C) Temp Rise	6.8 GPM (25.8 L/m)	8.4 GPM (32 L/m)		10.1 GPM (38 L/m)		11.2 GPM (42 L/m)	
	45 °F (25 °C) Temp Rise	5.3 GPM (20 L/m)	6.5 GPM (25 L/m)		7.8 GPM (30 L/m)		8.7 GPM (33 L/m)	
	67 °F (36 °C) Temp Rise	3.2 GPM (12 L/m)	4.3 GPM (16 L/m)	4.2 GPM (16 L/m)	5.0 GPM (19 L/m)	5.2 GPM (20 L/m)	5.6 GPM (21 L/m)	5.7 GPM (22 L/m)
Dimensions		17.3 in (W) x 27.4 in (H) x 13.2 in (D)						
Weight		62 lbs (28 kg)	75 lbs (34 kg)	67 lbs (30 kg)	82 lbs (37 kg)	75 lbs (34 kg)	82 lbs (37 kg)	75 lbs (34 kg)
Installation Type		Indoor or Outdoor Wall-Hung						
Venting Type		Forced Draft Direct Vent						
Ignition		Electronic Ignition						
Water Pressure		15-150 PSI						
Natural Gas Supply Pressure (from source)		3.5 in WC-10.5 in WC						
Propane Gas Supply Pressure (from source)		8 in WC-13 in WC						
Natural Gas Manifold Pressure (min-max)		-0.04 in WC - -0.40 in WC	-0.04 in WC - -0.84 in WC		-0.05 in WC - -0.36 in WC		-0.05 in WC - -0.58 in WC	
Propane Gas Manifold Pressure (min-max)		-0.05 in WC - -0.42 in WC	-0.05 in WC - -0.50 in WC		-0.10 in WC - -0.66 in WC		-0.10 in WC - -0.78 in WC	
Minimum Flow Rate		0.5 GPM (1.9 L/m), < 0.01 GPM (0.04 L/m) option for "A" models*						
Connection Sizes	Cold Water Inlet	¾ in NPT						
	Hot Water Outlet	¾ in NPT						
	Gas Inlet	¾ in NPT						
Power Supply	Main Supply	120 V AC, 60 Hz						
	Maximum Power Consumption	200 W (max 2 A), 350 W (max 4 A) with external pump connected						
Materials	Casing	Cold Rolled Carbon Steel						
	Heat Exchangers	Primary Heat Exchanger: Stainless Steel Secondary Heat Exchanger: Stainless Steel						
Venting	Exhaust	2 in or 3 in PVC, CPVC, Approved Polypropylene 2 in or 3 in Special Gas Vent Type BH (Class II, A/B/C)						
	Intake	2 in or 3 in PVC, CPVC, Approved Polypropylene 2 in or 3 in Special Gas Vent Type BH (Class II, A/B/C)						
	Vent Clearances	0 in to combustibles						
Safety Devices	Flame Rod, APS, Ignition Operation Detector, Water Temperature High Limit Switch, Exhaust Temperature High Limit Sensor, Power Surge Fuse							

* Available for "A" models configured in an optional ComfortFlow recirculation mode. Energy consumption will increase when the system is configured for recirculation.

2.4 The Front Panel

The front panel allows you to adjust the water temperature and view the operating status or error codes. Remove the protective sheet from the front panel before using it.

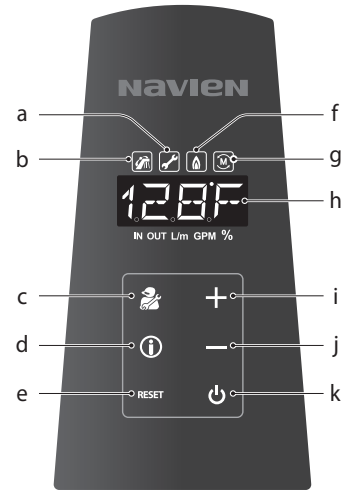

Error
A code will appear on the display



Hot Water Recirculation
Recirculation Mode



Diagnostics button
For installers only



Information button
Shows basic information



Reset button
Resets the water heater (When an error occurs)



Combusting
When the gas burner is on



Master Unit
Cascade operation



Display



Up button
Increases the temperature



Down button
Decreases the temperature



Power button
Turns the water heater on or off

2.5 Components

The following diagram shows the key components of the water heater. Component assembly diagrams and particular parts lists are included in the Appendixes.

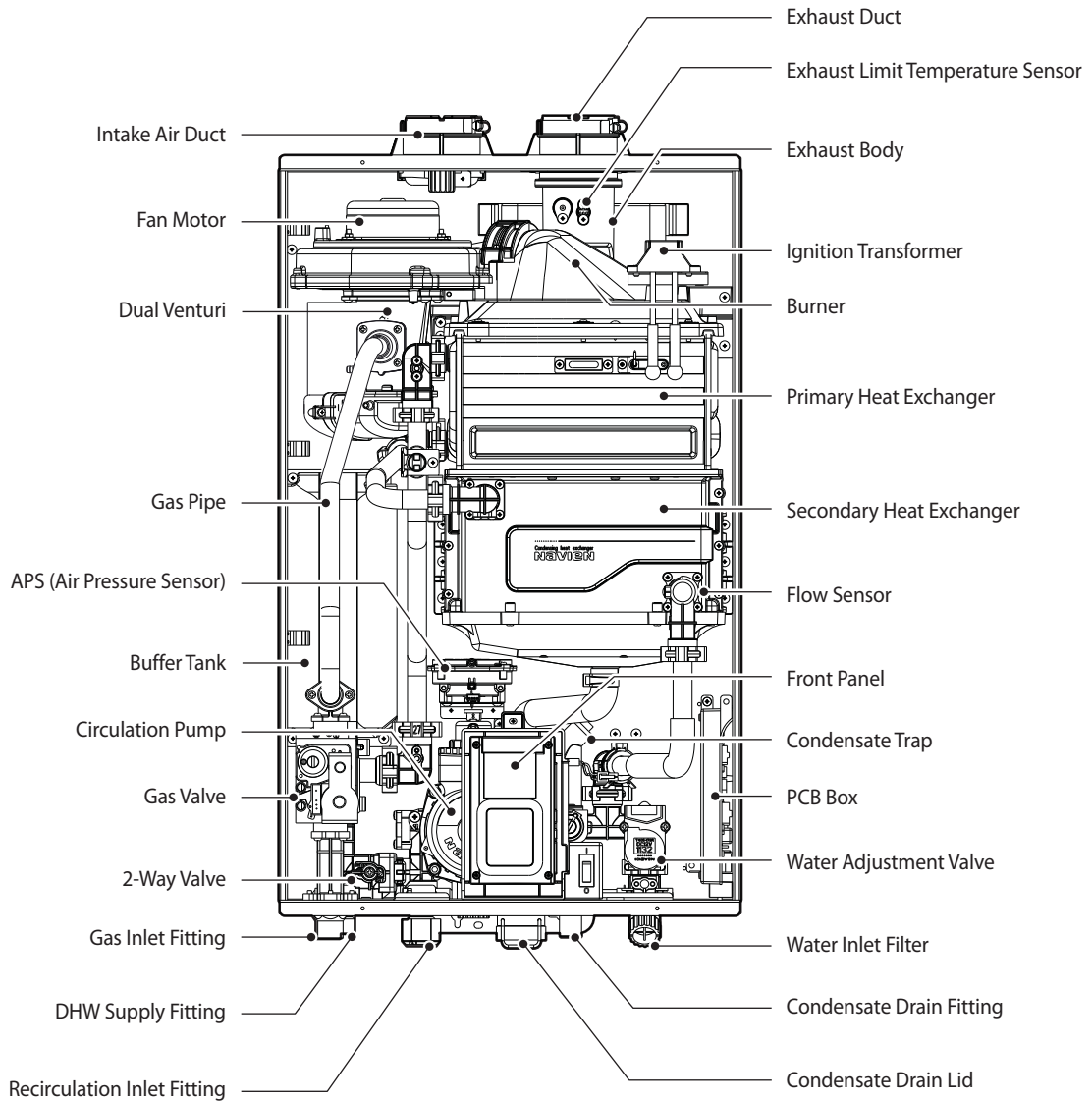

[NPE-180A/ 210A/ 240A]

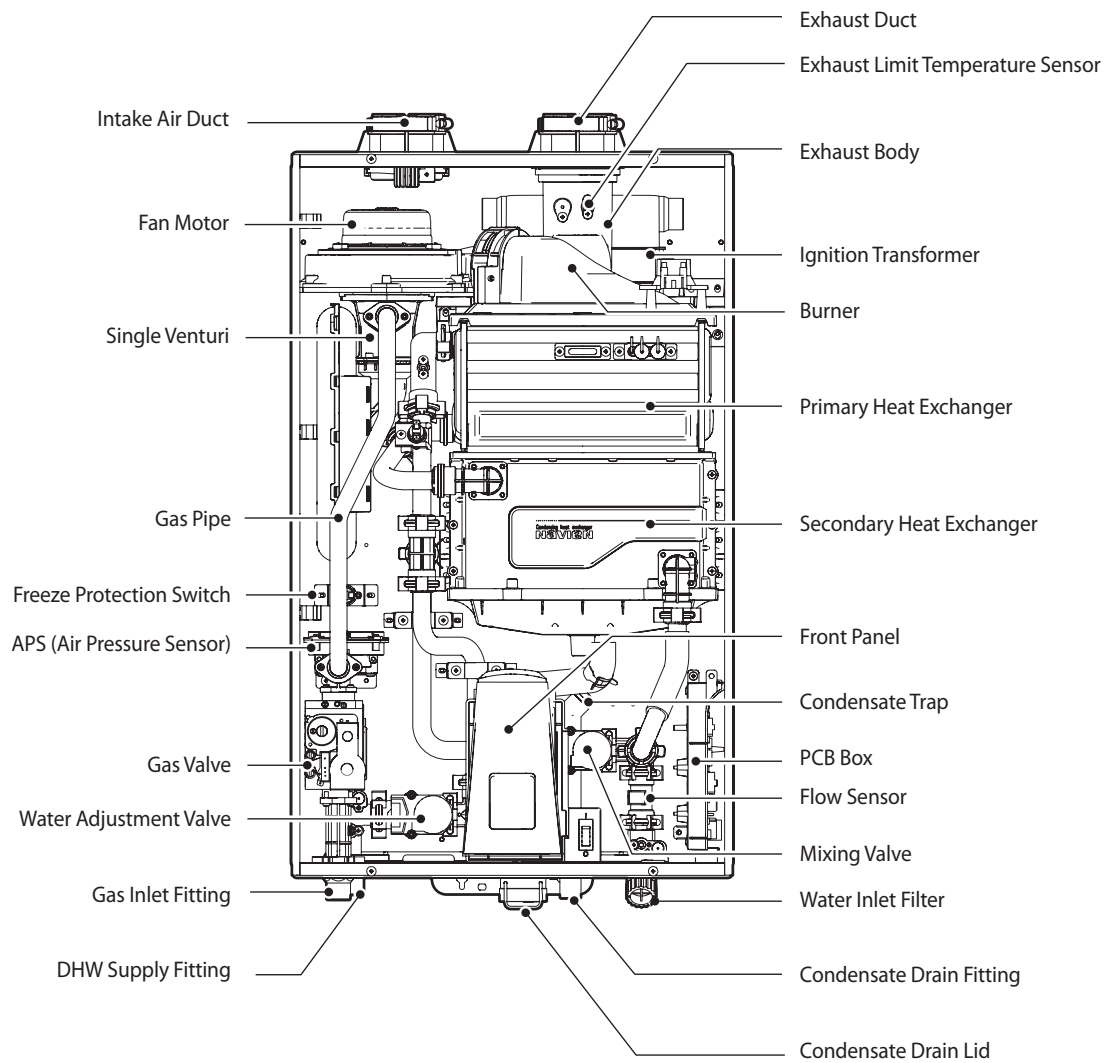

[NPE-150S]

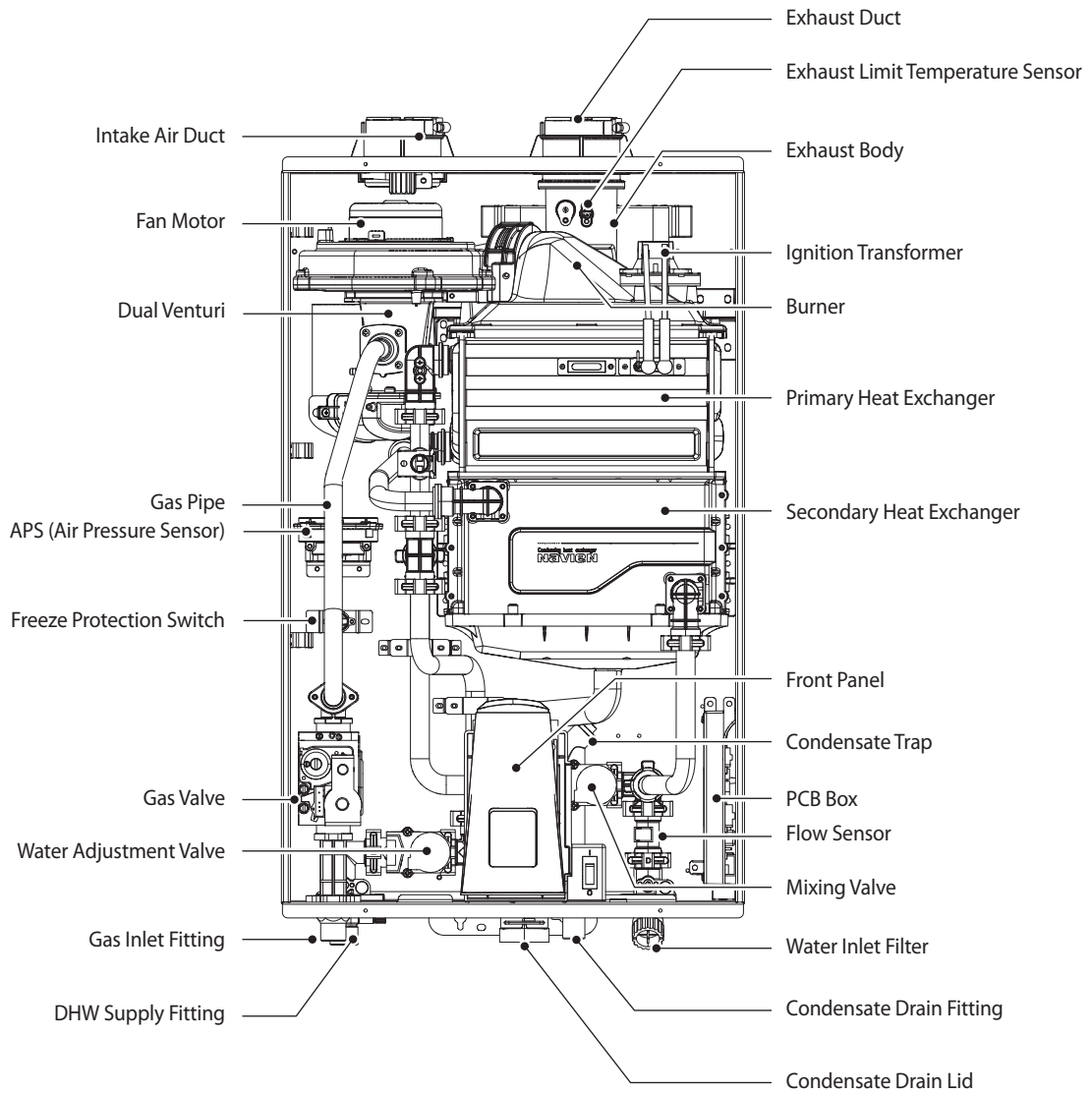

[NPE-180S/ 210S/ 240S]

2.6 Dimensions

The following diagrams show the dimensions of the water heater and the table lists the supply connections.

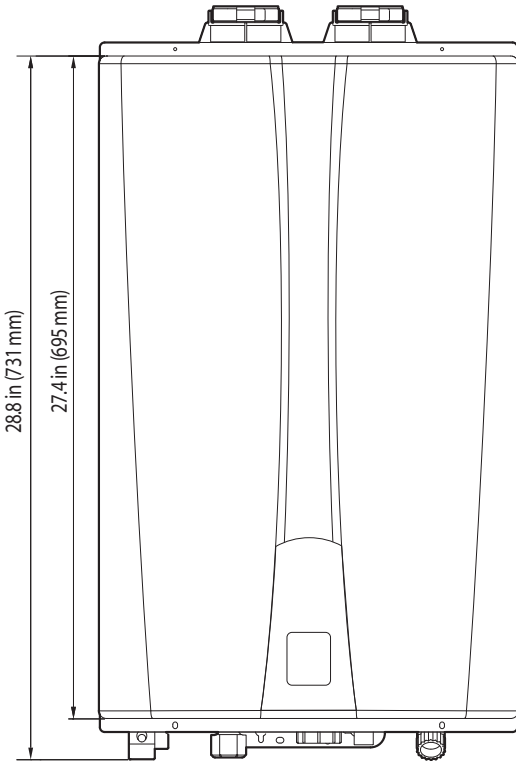

Supply Connections

	Description	Diameter
A	Air Intake	2 in
B	Exhaust Gas Vent	2 in
C	Hot Water Outlet	$\frac{3}{4}$ in
D	Recirculation Inlet	$\frac{3}{4}$ in
E	Cold Water Inlet	$\frac{3}{4}$ in
F	Gas Inlet	$\frac{3}{4}$ in
G	Condensate Outlet	$\frac{1}{2}$ in

Overhead View

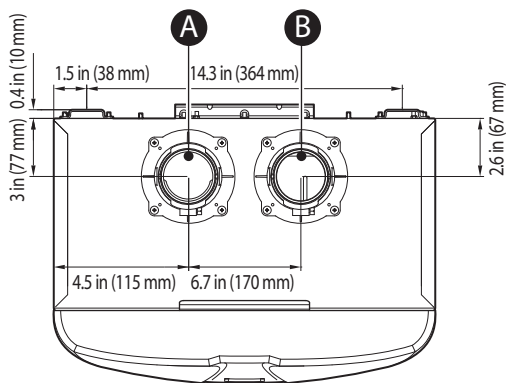

Supply Connections

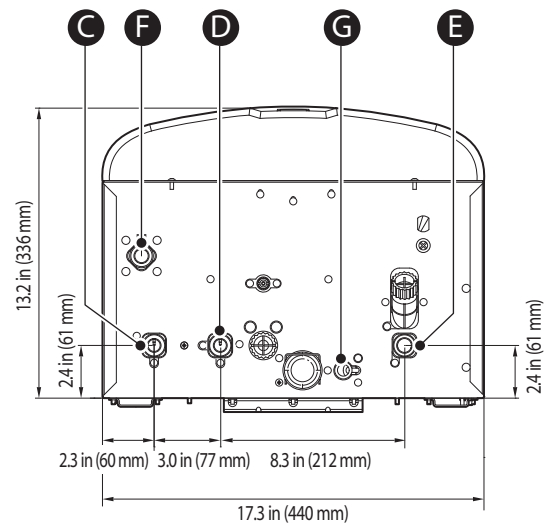

[NPE-180A/ 210A/ 240A]

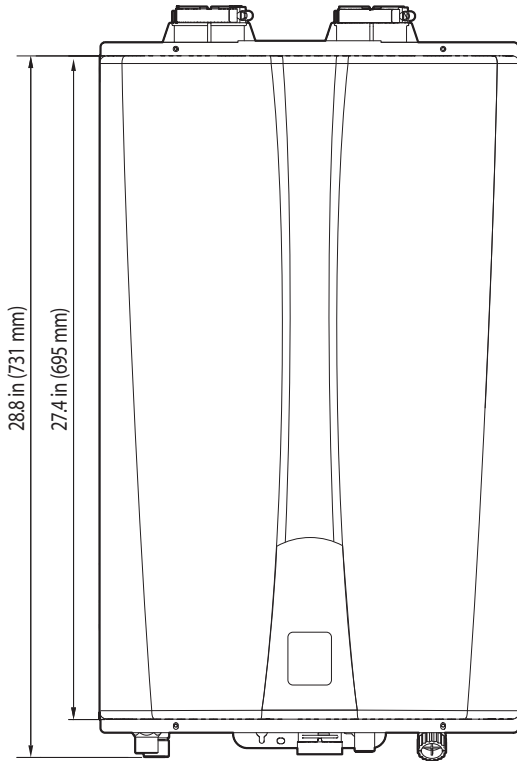

Supply Connections

	Description	Diameter
A	Air Intake	2 in
B	Exhaust Gas Vent	2 in
C	Hot Water Outlet	$\frac{3}{4}$ in
D	Cold Water Inlet	$\frac{3}{4}$ in
E	Gas Inlet	$\frac{3}{4}$ in
F	Condensate Outlet	$\frac{1}{2}$ in

Overhead View

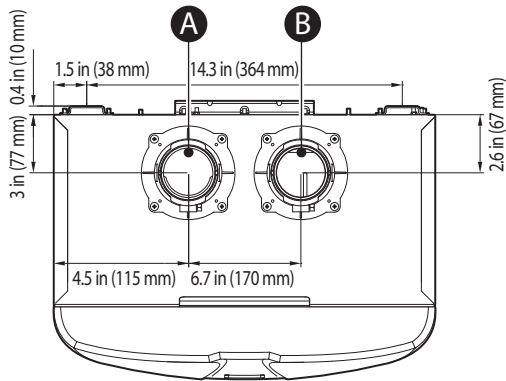

Supply Connections

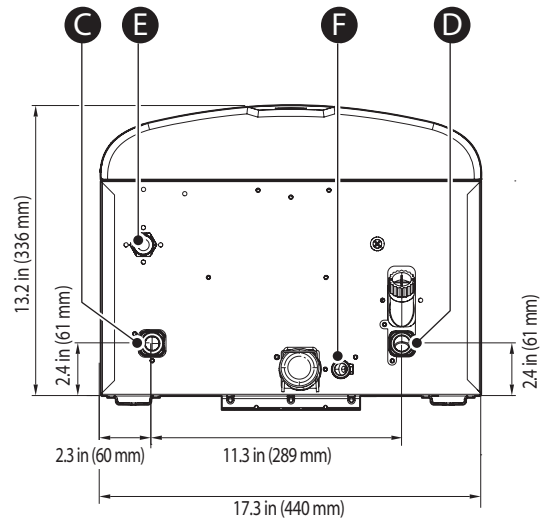

[NPE-150S/180S/ 210S/ 240S]

2.7 Rating Plate



Water Heaters come from the factory configured for use with Natural Gas (NG). **Before starting the installation**, check the rating plate located on the side of the water heater to ensure that the water heater matches the gas type, gas pressure, water pressure, and electrical supply available in the installation location. **If the water heater does not match each of these ratings, do not install the water heater.** If conversion to Propane Gas is required, the included gas conversion kit must be used. Refer to “6.1 Gas Conversion” for details.

Rating Plate, *Plaque Signalétique

Direct Vent Automatic Instantaneous Water Heater *Chauffe-eau instantané automatique à évent direct
For Indoor, Outdoor or Manufactured Home (Mobile Home) Installation *Pour installation dans une maison préfabriquée (mobile)

Navien, Inc.
 20 Goodyear, Irvine, CA 92618
 Tel: 1-800-519-8794

<p>Model No., *Numéro de modèle NPE-210A</p> <p>Max. Input Rating, *Entrée GPL max. 180,000 Btu/h</p> <p>Recovery Rating, *Calibre de recouvrement</p> <p>Max. Inlet Gas Pressure, *Pression max. de gaz d'entrée</p> <p>Min. Inlet Gas Pressure, *Pression min. de gaz d'entrée</p> <p>Manifold Pressure, *Pression d'admission</p> <p>Electrical Rating, *Régime nominal électrique</p> <p>Max. Water Pressure, *Pression d'eau max.</p>	<p>Type of Gas, *Type de gaz NG</p> <p>Min. Input Rating, *Débit calorifique max. 19,900 Btu/h</p> <p>265 Gallons/Hour, *gallons/heures</p> <p>10.5 Inches W.C., *pouces W.C.</p> <p>3.5 Inches W.C., *pouces W.C.</p> <p>-0.36 Inches W.C., *pouces W.C.</p> <p>AC *c.a. 120 Volts 60Hz, less than 2 amperes, *Utilise moins de 2A 150 psi *lb/po2 ANSI Z21.10.3 · CSA 4.3-2011</p>
--	---





LOW NOx
emissions
complies with SCAQMD rule 1146.2

Orifices necessary for LP conversion are provided. *Les injecteurs nécessaires à la conversion au GPL sont fournis.
Failure to use the correct gas can cause problems which can result in death, serious injury or property damage. *Le fait de ne pas utiliser le bon gaz peut causer des problèmes qui peuvent mener à la mort, causer des blessures graves ou endommager la propriété.
Consult your installation manual for more information. *Consultez votre manuel d'installation pour plus d'information.
Suitable for combination water (potable) heating and space heating and not suitable for space heating applications only.
 *Convient au chauffage combiné de l'eau (potable) et des locaux, mais non au chauffage des locaux seulement.
 This appliance is certified for use at altitudes up to 4,500 ft (1,370 m) in accordance to the latest CAN/CGA 2.17-High Altitude Installation procedures at normal manifold pressure. For installation instructions at altitudes higher than 4,500 ft, please contact Navien. *Cet appareil est certifié pour une utilisation à des altitudes de 0 à 4,500 pieds (1,370 m) conformément aux toutes les procédures d'installation à haute altitude CAN/CGA 2.17 à une pression normale. Pour les installations à élévations en haut de 4,500 pieds, appeler le bureau de Navien.
 This appliance must be installed in accordance with local codes, or in the absence of local codes, the National Fuel Gas Code, ANSI Z223.1/NFPA 54 or the CSA B149.1, Natural Gas and Propane Installation Code. *Cet appareil doit être installé selon les règlements locaux, ou en l'absence de tels règlements, selon le National Fuel Gas Code, ANSI Z223.1/NFPA 54, ou les, Code d'installation du gaz naturel et du propane, CSA-B149.1.

FOR YOUR SAFETY *POUR VOTRE SÉCURITÉ

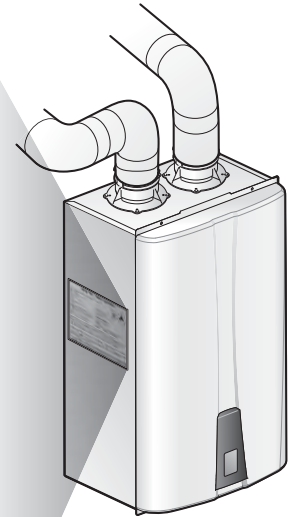
Do not store or use gasoline or other flammable vapors and liquids in the vicinity of this or any other gas appliances. *Ne rangez pas et n'utilisez pas d'essence ou d'autres liquides ou vapeurs inflammables près de cet appareil ou de tout autre appareil électroménager.



WARNING

- Be sure the gas type and electricity voltage match the rating plate. Using a different gas type will cause abnormal combustion and water heater malfunction.
- Using abnormally high or low AC voltage may cause abnormal operation, and may reduce the life expectancy of this product.

3. Installing the Water Heater

3.1 Choosing an Installation Location

When choosing an installation location, you must ensure that the location provides adequate clearance for the water heater, adequate venting and drainage options, and sufficient access to gas, water, and electrical supplies. Carefully consider the following factors when choosing an installation location:

About Water Quality

Proper maintenance of the water heater is required when water quality does not meet EPA standards. Damage caused by poor water quality is not covered under warranty. The following table shows the maximum contaminant levels allowed, based on the EPA National Secondary Drinking Water Regulations (40 CFR Part 143.3). If you suspect that your water is contaminated in any way, discontinue use of the water heater and contact an authorized technician or licensed professional.

Contaminant	Maximum Allowable Level
Total Hardness	Up to 200 mg/l (12 grains/gallon)
Aluminum	0.05 to 0.2 mg/l
Chloride	Up to 250 mg/l
Copper	Up to 1.0 mg/l
Iron	Up to 0.3 mg/l
Manganese	Up to 0.05 mg/l
pH	6.5 to 8.5
Sulfate	Up to 205 mg/l
Total Dissolved Solids (TDS)	Up to 500 mg/l
Zinc	Up to 5 mg/l
Chlorine	Up to 4 mg/l

Access to utilities

- Water – the installation location should be near where the domestic water supply enters the building.
- Gas – the installation location should be near where the gas supply enters the building.
- Electricity – the installation location should be near where the electrical supply enters the building.

Adequate drainage

The water heater produces a significant amount of condensate

- Maintain proper clearances from any openings in the building.
- Install the water heater with a minimum clearance of 12 in (300 mm) above an exterior grade or as required by local codes.
- Maintain a minimum clearance of 4 ft (1.2 m) from heating and cooling vents.
- Do not enclose the vent termination.
- Install the exhaust vent in an area that is free from obstructions and does not allow the exhaust to accumulate.
- Do not install the water heater where moisture from the exhaust may discolor or damage walls.
- Do not install the water heater in bathrooms, bedrooms, or any other occupied rooms that are normally kept closed or that are not adequately ventilated.

Proximity to fixtures and appliances

Install the water heater near fixtures that deliver or use hot water, such as bathroom, kitchen, and laundry room faucets. Select a location that minimizes the water piping required between major fixtures. If the distances are long or if the water heater requires “instant” hot water, we recommend running a recirculation line back to the water heater from the furthest fixture. Insulate as much of the hot water supply and recirculation lines as possible. For more information about the water supply, refer to “3.4 Connecting the Water Supply” on page 20.

Adequate installation clearances

Install the water heater in an area that allows for service and maintenance access to utility connections, piping, filters, and traps. Based on the installation location, ensure the following clearances are maintained:

Clearance from:	Indoor Installation	Outdoor Installation
Top	9 in (229 mm) minimum	36 in (900 mm) minimum
Back	0.5 in (20 mm) minimum	0.5 in (20 mm) minimum
Front	4 in (100 mm) minimum	24 in (600 mm) minimum
Sides	3 in (76 mm) minimum	3 in (76 mm) minimum
Bottom	12 in (300 mm) minimum	12 in (300 mm) minimum

Clean, debris and chemical-free combustion air

- Do not install the water heater in areas where dust and debris may accumulate or where hair sprays, spray detergents, chlorine, or similar chemicals are used.
- Do not install the water heater in areas where gasoline or other flammables are used or stored.
- Ensure that combustible materials are stored away from the water heater and that hanging laundry or similar items do not obstruct access to the water heater or its venting.
- In commercial locations, do not install the water heater in areas with greasy fumes or heavy amounts of steam or take measures to prevent fumes and steam from entering the water heater.

High Elevation Installations

This water heater may be installed at elevations up to 10,100 ft (3,078 m) for use with Natural Gas and 4,500 ft (1,370 m) for use with Propane. Refer to "3.8.2 Setting the Front Panel DIP Switches" on page 37 for the appropriate altitude setting.

3.2 Mounting the Water Heater to the Wall

Navien water heaters come with an upper mounting bracket that is pre-drilled at 16 in on center for easy installation on standard wall studs. If the strength of the wall is insufficient or if the framing is non-standard or uneven, reinforce the area before installing the water heater. Avoid installation on common walls as the unit will make some operational noises while it is running.

To mount the water heater to the wall:

1. Affix the bracket securely to the wall and ensure that it is level and that it can support the weight of the water heater.
2. Align the grooves on the back of the water heater with the tongues on the mounting bracket and hang the water heater on the bracket.

When mounted with the mounting bracket, the water heater will have a $\frac{5}{8}$ in (16 mm) clearance from the back of the wall.

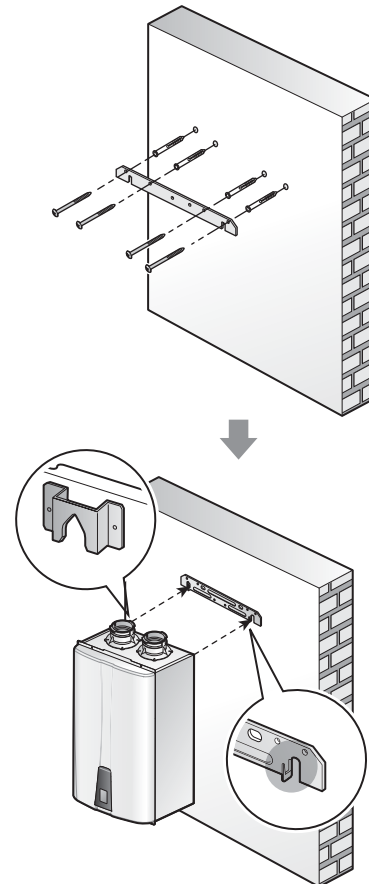

⚠ CAUTION

Do not mount the water heater to dry wall that has not been reinforced.

3.3 Connecting the Gas Supply

WARNING

- Before connecting the gas supply, determine the gas type and pressure for the water heater by referring to the rating plate. Use only the same gas type indicated on the rating plate. Using a different gas type will result in abnormal combustion and malfunction of the water heater. Gas supplies should be connected by a licensed professional only.
- The appliance and its gas connection must be leak tested before placing the appliance in operation.
- This water heater cannot be converted from natural gas to propane or vice versa without a Navien gas conversion kit. Do not attempt a field conversion of this water heater without a Navien gas conversion kit. Doing so will result in dangerous operating conditions and will void the warranty.

Navien recommends connecting the water heater as the first water heater downstream of the gas meter, to ensure a sufficient gas supply.

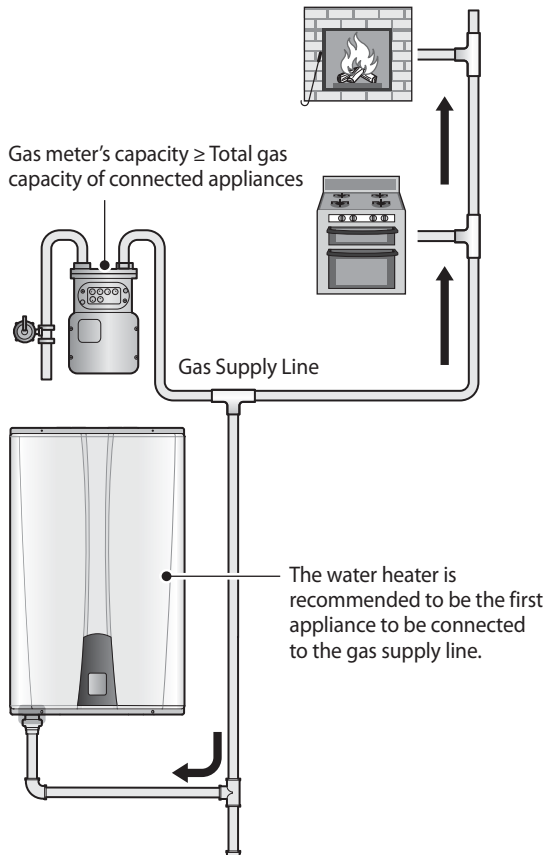

To connect the gas supply:

1. Determine the gas type and pressure for the water heater by referring to the rating plate.
2. Perform a pressure test on the main gas supply line.
3. Purge the gas line of any debris.
4. Determine the proper size and type for the gas line. Refer to the tables that follow.
5. Install full port valves on the gas supply line and water heater.
6. Connect the gas supply line.
7. Test the supply line, all connection points, and the water heater for gas leaks.

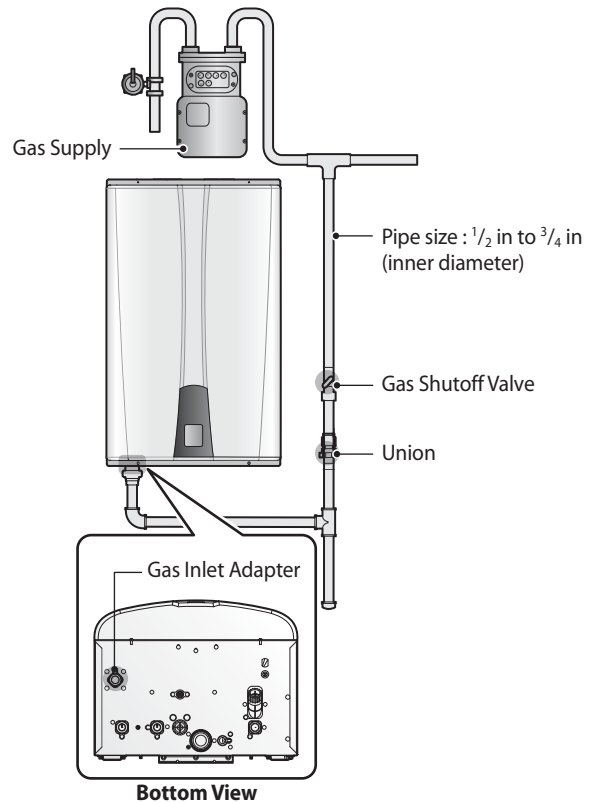

Note

- Tighten the water heater connection valves with care to avoid damage.
- The gas connection fitting on all water heaters is $\frac{3}{4}$ in.
- $\frac{1}{2}$ in rigid pipe can be used; refer to the sizing tables on the preceding pages for limitations. Avoid using $\frac{1}{2}$ in corrugated connectors or tubing as noise may occur.



Corrugated Connector

- When using flexible gas lines, ensure that the pipe's inner diameter and connector is sufficient to supply the required BTUs. Also, ensure that the flexible line has no crimps or tight bends in it, as this will restrict gas flow.
- When using rigid pipe, Navien recommends the installation of a union on the gas supply line close to the water heater, to facilitate any future maintenance or service.

CAUTION

Prior to using an excess flow valve (EFV) in the gas line, check the manufacturer's minimum and maximum flow capacity rating. An improperly sized EFV will not allow for a full flow of gas to the water heater and may cause improper operation.

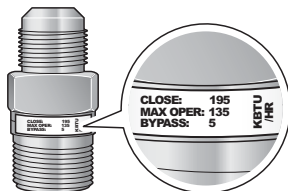

Excess Flow Valve

Typical LP Gas piping examples:

2 Stage System with Multiple Regulators (Recommended)

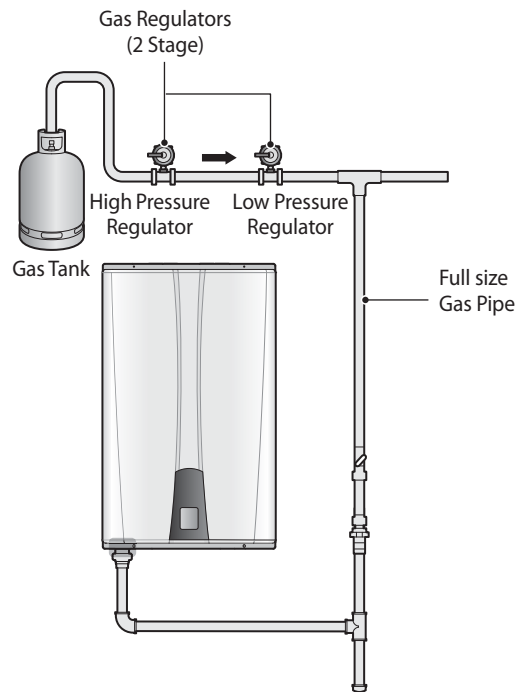

Single Regulator System

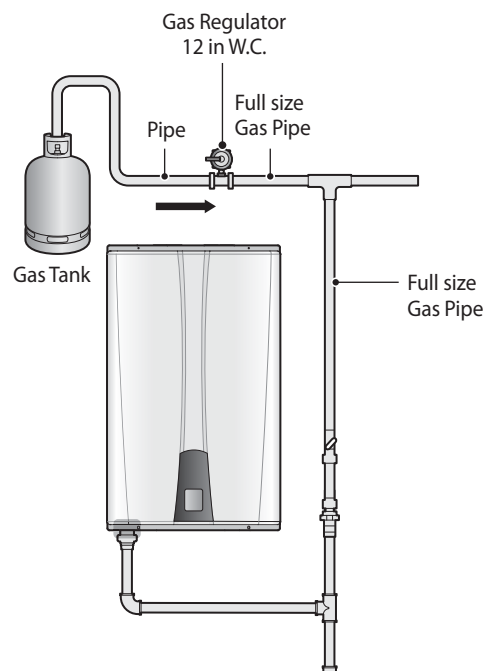

3.3.1 Gas Pipe Sizing Tables (Referenced from 2012 National Fuel Gas Code)

These tables are for reference only. Please consult the gas pipe manufacturer for actual pipe capacities.

Maximum Natural Gas Delivery Capacity

in Cubic Feet (ft³) per Hour (0.60 Specific Gravity; 0.5 in WC Pressure Drop). Contact your gas supplier for BTU/ft³ ratings. Use 1,000 BTU/ft³ for simplified calculations. This table is recommended for supply pressures less than 6 in WC.

Pipe Size	Length (including fittings)										
	10 ft (3 m)	20 ft (6 m)	30 ft (9 m)	40 ft (12 m)	50 ft (15 m)	60 ft (18 m)	70 ft (21 m)	80 ft (24 m)	90 ft (27 m)	100 ft (30 m)	125 ft (38 m)
3/4 in	360	247	199	170	151	137	126	117	110	104	92
1 in	678	466	374	320	284	257	237	220	207	195	173
1 1/4 in	1,390	957	768	657	583	528	486	452	424	400	355
1 1/2 in	2,090	1,430	1,150	985	873	791	728	677	635	600	532
2 in	4,020	2,760	2,220	1,900	1,680	1,520	1,400	1,300	1,220	1,160	1,020
2 1/2 in	6,400	4,400	3,530	3,020	2,680	2,430	2,230	2,080	1,950	1,840	1,630
3 in	11,300	7,780	6,250	5,350	4,740	4,290	3,950	3,670	3,450	3,260	2,890
4 in	23,100	15,900	12,700	10,900	9,660	8,760	8,050	7,490	7,030	6,640	5,890

in Cubic Feet (ft³) per Hour (0.60 Specific Gravity; 3.0 in WC Pressure Drop). Contact your gas supplier for BTU/ft³ ratings. Use 1,000 BTU/ft³ for simplified calculations. This table is recommended for supply pressures of 6 in WC or greater.

Pipe Size	Length (including fittings)										
	10 ft (3 m)	20 ft (6 m)	30 ft (9 m)	40 ft (12 m)	50 ft (15 m)	60 ft (18 m)	70 ft (21 m)	80 ft (24 m)	90 ft (27 m)	100 ft (30 m)	125 ft (38 m)
1/2 in	454	312	250	214	190	172	158	147	138	131	116
3/4 in	949	652	524	448	397	360	331	308	289	273	242
1 in	1,787	1,228	986	844	748	678	624	580	544	514	456
1 1/4 in	3,669	2,522	2,025	1,733	1,536	1,392	1,280	1,191	1,118	1,056	936
1 1/2 in	5,497	3,778	3,034	2,597	2,302	2,085	1,919	1,785	1,675	1,582	1,402
2 in	10,588	7,277	5,844	5,001	4,433	4,016	3,695	3,437	3,225	3,046	2,700
2 1/2 in	16,875	11,598	9,314	7,971	7,065	6,401	5,889	5,479	5,140	4,856	4,303
3 in	29,832	20,503	16,465	14,092	12,489	11,316	10,411	9,685	9,087	8,584	7,608
4 in	43,678	30,020	24,107	20,632	18,286	16,569	15,243	14,181	13,305	12,568	11,139

Maximum Liquefied Propane Delivery Capacity

in Thousands of BTU/H (0.5 in WC Pressure Drop)

Pipe Size	Length (including fittings)												
	10 ft (3 m)	20 ft (6 m)	30 ft (9 m)	40 ft (12 m)	50 ft (15 m)	60 ft (18 m)	80 ft (24 m)	100 ft (30 m)	125 ft (38 m)	150 ft (45 m)	175 ft (53 m)	200 ft (60 m)	250 ft (76 m)
1/2 in	291	200	160	137	122	110	101	94	89	84	74	67	62
3/4 in	608	418	336	287	255	231	212	197	185	175	155	140	129
1 in	1,150	787	632	541	480	434	400	372	349	330	292	265	243
1 1/4 in	2,350	1,620	1,300	1,110	985	892	821	763	716	677	600	543	500
1 1/2 in	3,520	2,420	1,940	1,660	1,480	1,340	1,230	1,140	1,070	1,010	899	814	749
2 in	6,790	4,660	3,750	3,210	2,840	2,570	2,370	2,200	2,070	1,950	1,730	1,570	1,440

3.3.2 Measuring the Inlet Gas Pressure



WARNING

The water heater cannot function properly without sufficient inlet gas pressure. Measuring the inlet gas pressure should be performed by a licensed professional only.

- The inlet gas pressure must be maintained between 3.5 in and 10.5 in WC for natural gas and between 8.0 in and 13 in WC for liquefied propane.
- The appliance and its individual shutoff valve must be disconnected from the gas supply piping system during any pressure testing of that system at test pressures in excess of 1/2 psi (3.5 kPa). The appliance must be isolated from the gas supply piping system by closing its individual manual shutoff valve during any pressure testing of the gas supply piping system at test pressures equal to or less than 1/2 psi (3.5 kPa).

To measure the inlet gas pressure:

1. Shut off the manual gas valve on the gas supply line.

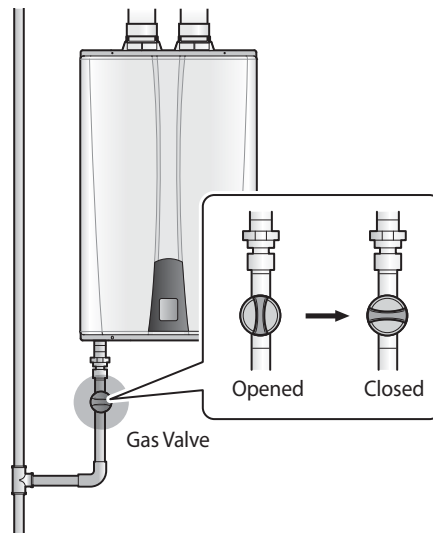

- Open a hot water faucet. The water heater should turn on and the gas in the gas supply line will be purged.
- Leave the faucet on until the water heater shuts down due to a lack of gas supply, and then turn off the hot water faucet.
- Remove the water heater front cover by loosening the 4 Phillips head screws securing it to the case.

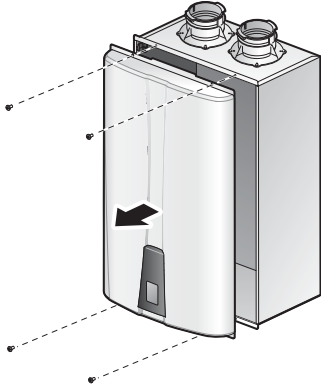

- Loosen the screw indicated in the figure below and connect a manometer to the pressure port. Reset the manometer to zero before use.

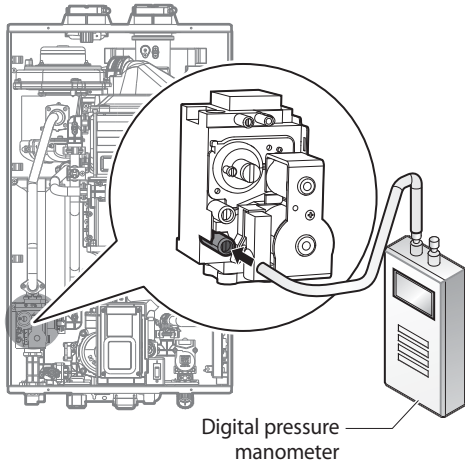

- Re-open the manual gas valve and check for leaks.
- Open multiple fixtures that have high flow rates, such as bathtub and shower faucets, to ramp the water heater up to its maximum firing rate.

- When the water heater reaches its maximum firing rate, check the inlet gas pressure reading on the manometer. The gas pressure must fall within the ranges specified on page 19.

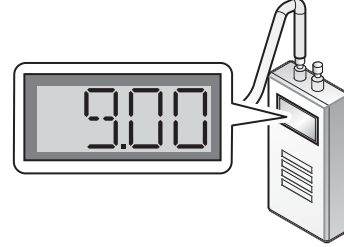

3.4 Connecting the Water Supply

The water fittings on the water heater are $\frac{3}{4}$ in. If the installation site only has $\frac{1}{2}$ in plumbing throughout, it is not necessary to upsize the water lines to $\frac{3}{4}$ in, if you are installing a single water heater. When installing multiple water heaters, the number of water heaters and pipe sizing required will depend on the total hot water demand. For information about pipe sizing for multiple water heaters, refer to "4.1.1 Piping Sizes and Considerations" on page 40.

When connecting the water supply, follow these guidelines:

- Do not remove the factory installed recirculation inlet cap unless a return line is connected to this fitting. Water leakage will occur if this cap is loose or missing ("A" model only).
- Use only pipes, fittings, valves, and other components, such as solder, that are approved for use in potable water systems.
- Tighten the water heater connection valves with care to avoid damage.
- We recommend using unions and manual shut-off valves on the cold water inlet, DHW outlet, and recirculation water inlet.
- Strive to make the hot water piping system as short as possible, to deliver hot water to the fixtures more quickly.
- To conserve water and energy, insulate all water piping—especially the hot and recirculation water lines. Never cover the drain or pressure relief valve. If the water heater is installed in a closed water supply system, such as one having a backflow preventer in the cold water supply line, means shall be provided to control thermal expansion. Contact the water supplier or local plumbing inspector for information about how to control this situation.
- After installing the water heater, clean the inlet water filter that is located inside the cold water inlet, and then test the water heater for proper flow and inspect for leaks. Instruct the water heater owner that the filter must be cleaned periodically to maintain proper water flow.

- The following is a typical water piping example for NPE-180A/ 210A/ 240A models.

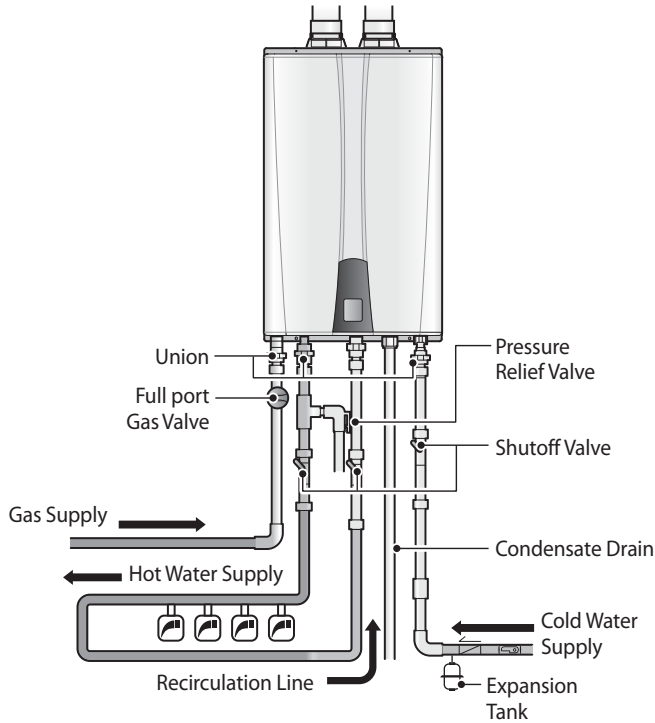

[NPE-180A/ 210A/ 240A]

- The following is a typical water piping example for NPE-180S/ 210S/ 240S models.

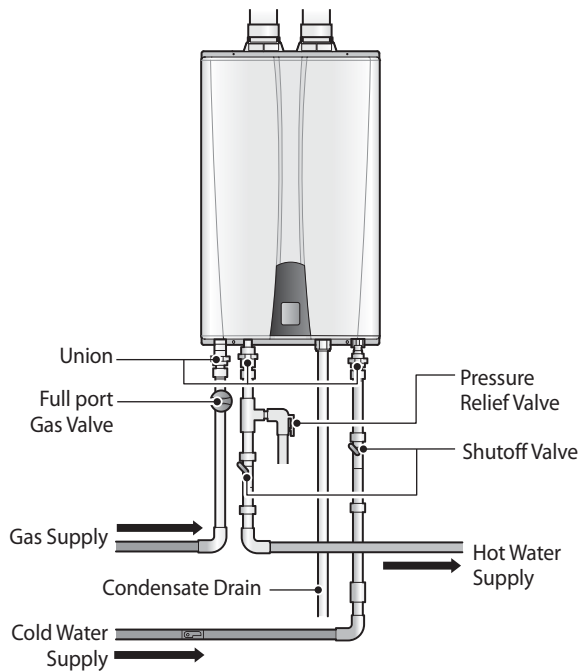

[NPE-180S/ 180S/ 210S/ 240S]

3.4.1 Using the Water Heater for Combination Water Heating and Space Heating

When using the water heater for both water (potable) heating and space heating, follow these guidelines:

- Ensure that all piping and components connected the water heater are suitable for potable water applications.
- Do not introduce toxic chemicals, such as boiler treatments, into the potable water.
- On Combi applications, circulators suitable for DHW applications must be used.
- Do not connect the water heater to any heating systems or components that have been previously used with non-potable water heaters.
- If the system requires varying temperatures for water—for example, hotter water for space heating than for other uses—install a mixing valve to temper the water and reduce the potential for scalding.
- Do not use the water heater for space heating only.
- Make sure circulator flow rate through the Water Heater does not exceed 4 GPM.

CAUTION

Do not configure the system for DHW recirculation when it is configured to run an air handler using the H2Air add-on controller. DHW recirculation and Navien H2Air configurations cannot be used at the same time.

3.4.2 Selecting a Recirculation Mode ("A" model only)

On all "A" model Navien water heaters, you can choose from two pre-heating modes: internal recirculation mode or external recirculation mode. To select a recirculation mode, you must set the DIP switches on the front panel, and set the position of the 2-way valve inside the water heater. By default, the DIP switches are set to OFF.

When the optional ComfortFlow recirculation mode is activated, energy consumption increases because the water heater operates to maintain the water temperature within the circulation loop. You can use the Navien Intelligent Preheating feature, set the timer on the optional Remote Controller, or install the HotButton kit accessories to reduce energy consumption.

The recirculation feature of the "A" models has three performance advantages:

- Elimination of any minimum flow rate requirement.
- Elimination of any hot/cold/hot stacking—the "cold water sandwich" effect.
- Quicker hot water delivery to fixtures, which results in less water wasted.

Note

When using external recirculation mode with the built-in pump, observe the following maximum recirculation pipe lengths including fittings ($\frac{3}{4}$ in pipe is recommended):

- $\frac{1}{2}$ in Copper Pipe- 100 ft (30 m) of equivalent length
 - $\frac{3}{4}$ in Copper Pipe- 500 ft (150 m) of equivalent length
- Lengths in excess of these limits will require an external recirculation pump.

Internal Recirculation Mode

To use the internal recirculation mode:

1. Connect the water supply.
2. Set the 2-way valve inside the water heater to "INT."

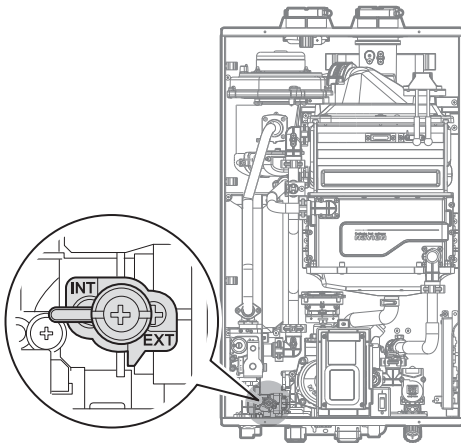

3. Set the front panel DIP switches at the far left (set of ten) to: 1—ON; 2—OFF.

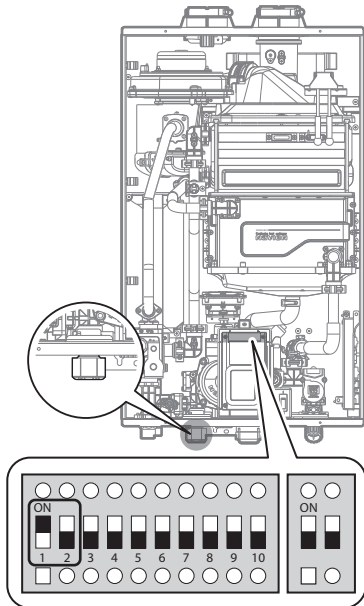
**CAUTION**

Do not remove recirculation cap. (Internal Recirculation Mode)

The following diagram shows the internal recirculation flow for pre-heating:

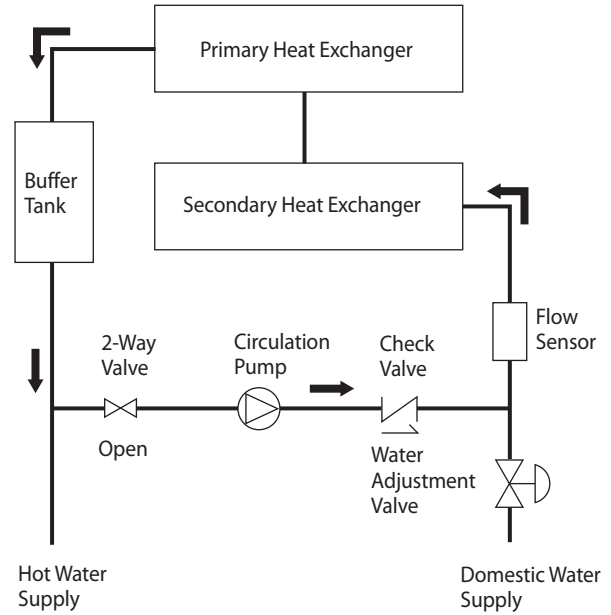

Internal Recirculation Mode

External Recirculation Mode

To use the external recirculation mode:

1. Connect the water supply to support recirculation. Refer to the "[NPE-180A/ 210A/ 240A]" diagram on page 21.
2. Set the 2-way valve inside the water heater to "EXT."

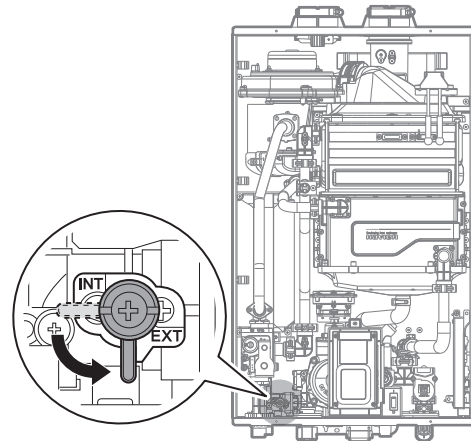

- Set the front panel DIP switches at the far left (set of ten) to: 1—OFF; 2—ON.

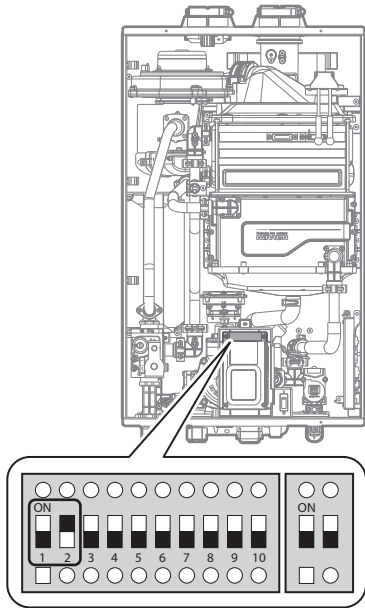

The following diagram shows the external recirculation flow for pre-heating:

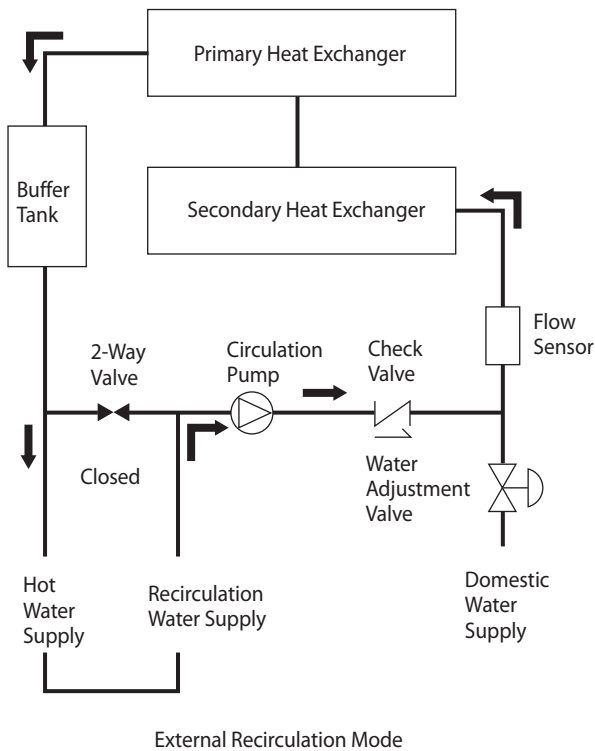

3.4.3 External Pump Wire Connection

An external pump may be connected to the water heater for recirculation applications. When selecting a circulator, it shall be sized to maintain a flow of 2-4 GPM through the water heater. Follow the instructions below when connecting the pump wire accessory to the PCB.

! WARNING

Failure to follow the instructions below may result in property damage, personal injury or death. To avoid the danger of electric shock, make sure that the water heater is turned off before connecting the wire to the PCB.

! CAUTION

An external pump cannot be used in an external recirculation mode application utilizing a by-pass Valve.

<Specifications>

- Maximum Power Consumption: 150W, 1.5A
- Length: 6 ft (183 cm)
- ※ When using a pump with larger power requirements than the listed specification above, a relay should be used to ensure proper operation.

- Remove the water heater front cover by loosening the 4 Phillips head screws securing it to the case.

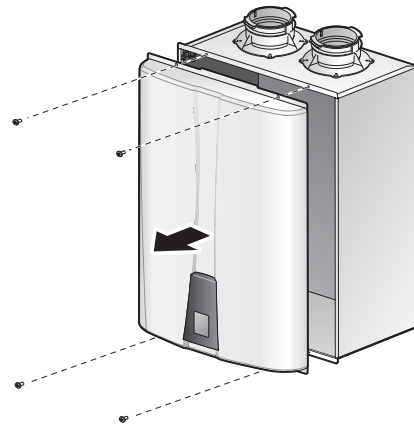

2. Locate the power switch on the right side of the front panel and switch the system off.

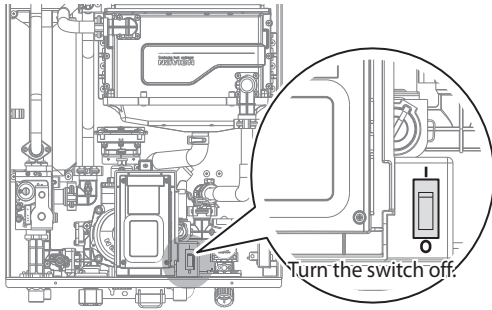

3. Remove the 2 screws holding the PCB box in place and remove the PCB box from the system.

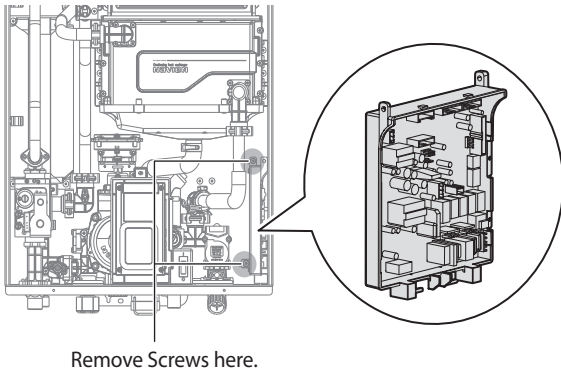

4. Connect the external pump wiring connector to the connector socket on the PCB (TB1).

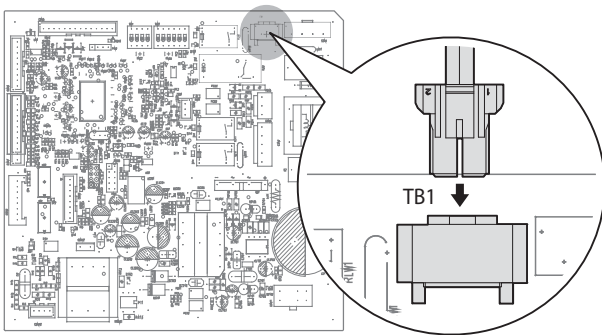

5. Put the PCB box back in its original place and secure it using the 2 mounting screws.

6. Remove the plastic insulation from the external pump wire with a wire stripper before connecting it to the pump.

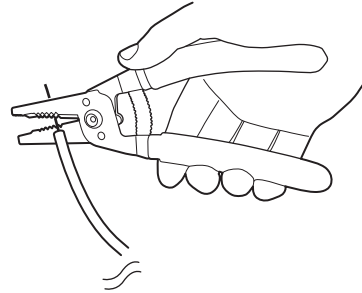

7. Connect the External Pump Wire to the proper wires from the pump junction box.

WARNING

To avoid the danger of electric shock, turn on the water heater ONLY after connecting the wire to the external pump.

8. Locate the 10-switch DIP (SW1) on the front panel and turn on the proper switches based on the desired recirculation setting (see Recirculation Dipswitch Settings below).

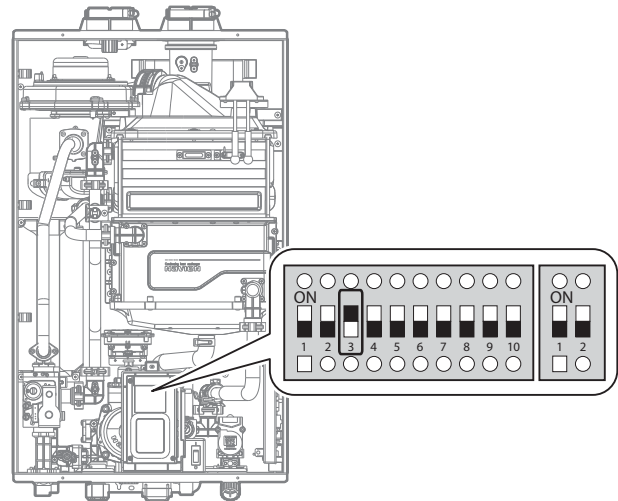

9. Turn on the switch beside the front panel.

10. Put the water heater cover back on and secure it with the 4 screws.

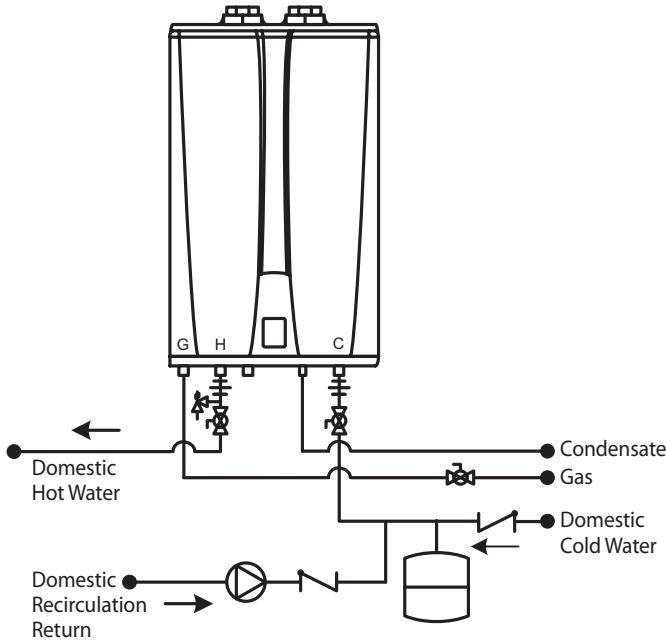

Recirculation Using External Pump Only

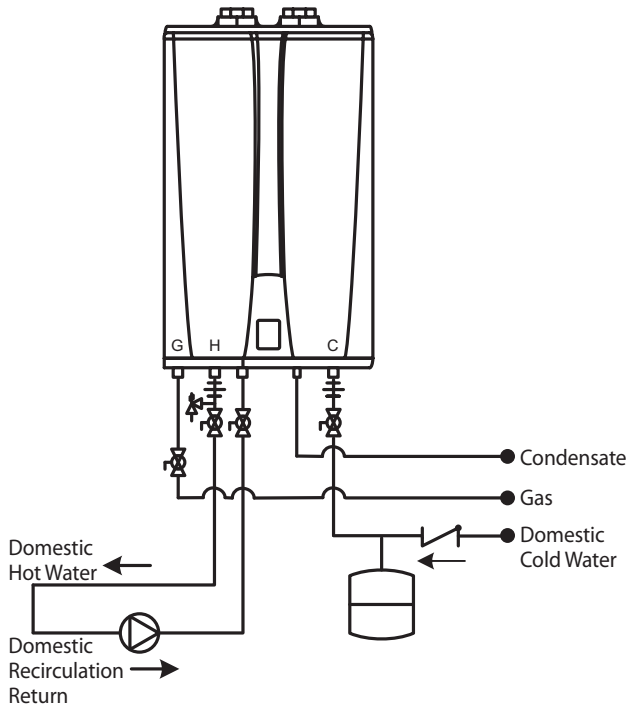

**Recirculation Using Two Pumps
(Navien Internal Pump & External Pump)**

3.4.4 Connecting a Pressure Relief Valve

! WARNING

Improper installation of the pressure relief valve may result in property damage, personal injury, or death. Follow all instructions and guidelines when installing the pressure relief valve. The valve should be installed only by a licensed professional.

To complete the installation of the water heater, you must install an approved $\frac{3}{4}$ in, maximum 150 PSI pressure relief valve on the hot water outlet. The water heater has a built-in high temperature shut off switch, so install a "pressure only" relief valve. This valve is not supplied, but is required. The following examples are approved for use with the water heater:

- Wilkins P-1000A (Zurn Industries)
- Conbraco 17-402-04
- Watts Industries 3L(M7)
- Cash Acme FWL-2, $\frac{3}{4}$ in

The pressure relief valve should be placed as close to the water heater as possible. No other valve should be placed between the pressure relief valve and the water heater.

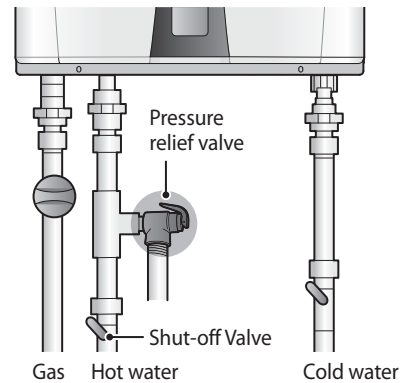

When installing the valve, follow these guidelines:

- Ensure that the discharge capacity of the pressure relief valve is equal to or greater than the maximum pressure rating of the water heater.
- Ensure that the maximum BTU/H rating on the pressure relief valve is equal to or greater than the maximum input BTU/H rating of the water heater.
- Direct the discharge piping of the pressure relief valve so that hot water will not splash on anyone or any nearby equipment.
- Attach the discharge line to the pressure relief valve and run the end of the line to within 6-12 in (150-300 mm) of the floor.
- Ensure that the discharge line will allow free and complete drainage without restriction. Do not install a reducing coupling or other restriction on the discharge line.
- If the relief valve discharges periodically, this may be due to thermal expansion in a closed water supply system. Contact the water supplier or local plumbing inspector on how to correct this situation. Do not plug the relief valve.

3.5 Connecting the Condensate Drain

The Navien Condensing Water Heater creates condensation when it operates. This condensation has an acidic pH of 3-5. Follow all local codes and regulations when disposing of condensate from the water heater. We recommend draining the condensate into a laundry tub, as the alkali in laundry detergent will neutralize the acid in the condensate. However, other suitable waste drain locations may be used according to local codes.

CAUTION

- Do not cap or plug the integrated condensate line. If prevented from draining, condensate can damage the water heater.
- The condensate line must have a negative slope to drain properly.

Before connecting the condensate drain, choose one of the following disposal options:

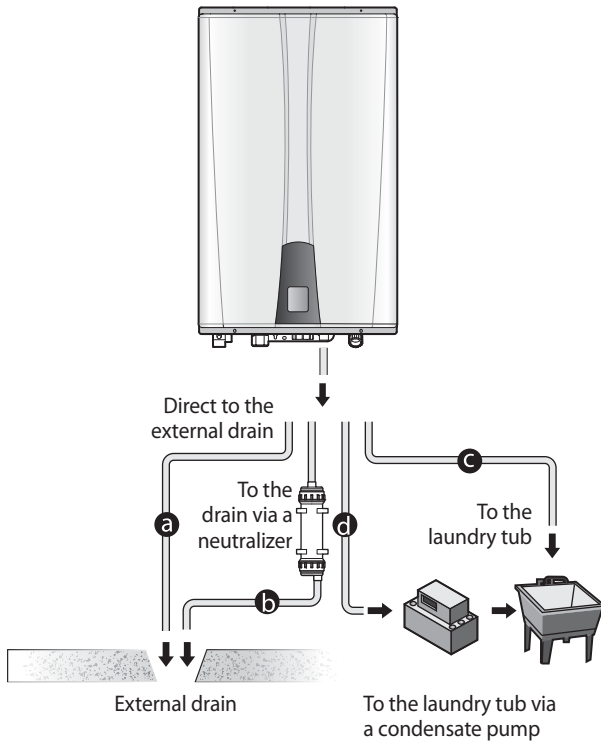

- a. From the water heater directly into an external drain.
- b. From the water heater, through a neutralizing agent, and then into an external drain.

Note If you choose this option, the neutralizing agent must be replaced periodically. Depletion of the neutralizing agent will vary, based on the usage rate of the water heater. During the first year of operation, the neutralizer should be checked every few months for depletion and replaced as needed.

- c. From the water heater into a laundry tub.

Note The bottom of the water heater must be higher than the top of the laundry tub to use this option. The condensate line must have a negative slope to drain properly.

- d. From the water heater into a condensate pump, and then into a laundry tub.

Note A pump can be used when there is a long distance between the water heater and the laundry tub or when the bottom of the water heater is lower than the top of the laundry tub.

To connect the condensate drain:

1. Connect a drain line to the 1/2 in fitting at the bottom of the water heater.
Use only corrosion-resistant material for the drain line, such as PVC or CPVC. Do not reduce the size of this fitting or the drain line to less than 1/2 in.

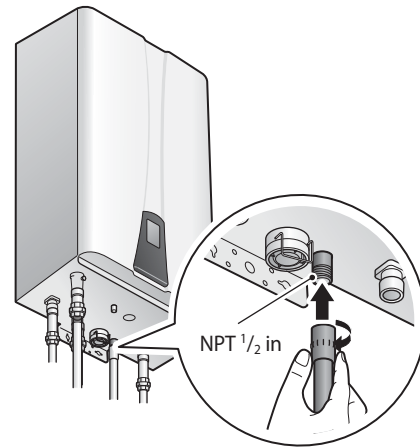

2. Place the free end of the drain line into an appropriate drain.
3. If you are using a condensate pump, ensure that the pump allows for up to 2 GPH of drainage for each water heater in the system.
If you are not using a condensate pump, ensure that the drain line is pitched downward at a minimum slope of 1/4 in per foot.

3.5.1 Condensate Neutralizer Kit

WARNING

- To avoid damaging the appliance, the neutralizer inlet and discharge must be lower than the condensate drain.
- Do NOT allow exhaust flue gases to vent through the neutralizer. Leakage can cause injury or death from carbon monoxide.
- The connection between the appliance and the neutralizer must be installed to prevent the backflow of condensate into the appliance.
- Do not connect more than one appliance to the neutralizer.

If option 'b' is selected for condensate disposal, the Navien condensate neutralizer kit is recommended. The condensate from the appliance flows through the neutralizing media and increases the pH of the condensate. An increased pH prevents corrosion of the installation's drainage system and the public sewer system.

Installation

- The inlet has a center connection port and the outlet has an offset connection.
- Install the neutralizer on the wall or the floor and secure it using the brackets supplied with the kit.
- If the neutralizer is installed horizontally, rotate the neutralizer to position the outlet at the highest point (Figure 1).
- If the neutralizer is mounted vertically, ensure that the outlet is higher than the inlet (Figure 2).
- Ensure that the condensate runs freely to the drain.
- Ensure all connections are made to prevent the backflow of condensate. Use corrosion resistant piping and secure all piping to prevent movement.

Note Do not install condensate piping in areas where the temperature drops below freezing point. Protect piping in high pedestrian areas from damage and vibration.

- For increased safety when the condensate drain blocks, install a Y-fitting. Connect the Y-fitting as shown in the installation diagram and ensure that the condensate runs freely to the drain.
- Ensure that the discharge connection is accessible. Access to the discharge connection is required for maintenance and pH testing.
- If there is insufficient gradient for drainage, install a drainage pump designed for boiler and water heater condensate removal.

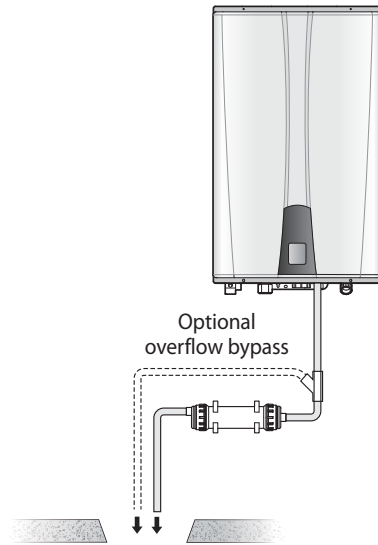

Figure 1. Horizontal installation

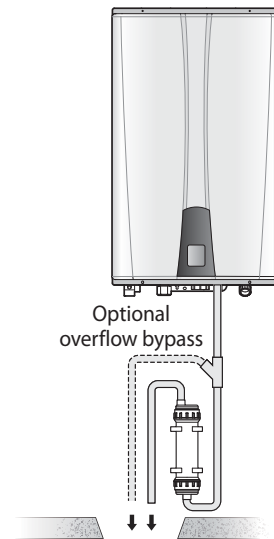

Figure 2. Vertical installation

Maintenance

Periodically monitor the level of media in the neutralizer and test the pH level at the outlet. We recommend an annual pH test using recognized test strips or an electronic pH meter to obtain precise measurements. Replace the neutralizing media when the pH drops below the minimum level required by the local water authority. If the pH level is not specified, replace the neutralizing media when the pH is below 6.0. For replacement media, contact your local Navien distributor.

3.6 Venting the Water Heater



WARNING

Improper venting of the water heater can result in excessive levels of carbon monoxide, which can lead to severe personal injury or death. **This water heater must be vented in accordance with the “Venting of Equipment” section of the latest edition of the ANSI Z223.1/NFPA 54 National Fuel Gas Code in the USA and/or the “Venting systems and air supply for water heaters” section of the latest version of the CAN/CGA B149.1 Natural Gas and Propane Installation Code in Canada, as well as all applicable local building codes and regulations.** Follow all instructions and guidelines when venting the water heater. Venting should be performed only by a licensed professional.

The water heater must be properly vented to ensure a constant supply of clean intake air and to ensure that exhaust air is properly removed from living areas. When venting the water heater, follow these guidelines:

- Do not install the water heater in areas with contaminated air (containing a high level of dust, sawdust, sand, flour, aerosols, or any other such airborne contaminants), as contaminants can cause operational problems. The warranty does not cover damage caused by contaminants in the installation area. If you must install the water heater in an area with contaminated air, use direct venting to supply air from outside the building. We recommend regular filter cleaning and maintenance in these areas.
 - For best results, keep the venting system as short and straight as possible.
 - Locate the water heater as close as possible to the vent termination.
 - Do not connect the water heater vent to a vent for any other gas water heater or vent stack.
 - For horizontal runs, slope the horizontal section upward toward the vent termination at a rate of $\frac{1}{4}$ in per foot (2 % slope).
 - Create an airtight seal at each joint in the exhaust and intake air pipes from the water heater collar to the vent termination.
 - To avoid moisture and frost build-up and to maintain clearances to openings on adjacent homes, 45° elbows, 90° elbows, or tees may be attached to the end of the termination vent pipe to direct the exhaust plumes away from buildings, as long as the total allowable vent lengths, maximum number of elbows, and distances to air intake restrictions are observed.
- Do not store hazardous or flammable substances near the vent termination.
 - If this water heater will be installed in areas where snow is known to accumulate, protect the vent termination from blockage.
 - Ensure that the vent termination is at least 12 in (305 mm) above the highest anticipated snow line, or as required by local codes, whichever is greater.
 - Support the vent pipe with hangers at regular intervals or as required by local codes.
 - Exhaust and intake air pipes must be supported at least every 4 ft (1.2 m).
 - The vent for this appliance shall not terminate over public walkways; or near soffit vents or crawl space vents or where condensate or vapor could create a nuisance or hazard or cause property damage; or where condensate or vapor could cause damage or could be detrimental to the operation of regulators, relief valves, or other equipment.

3.6.1 Selecting a Vent Type

All water heaters are prepared at the factory to be direct vent (sealed combustion) water heaters that draw all of their required combustion air directly from outside the building. Navien recommends direct air vent installations whenever possible to avoid back drafting cold air through the water heater. If you cannot use a direct vent, ensure that an ample supply of make-up air is available in the installation location.

Navien also recommends installing a new vent system with this appliance. If reusing an existing vent system, thoroughly inspect it for punctures, cracks, or blockages prior to connecting it to the water heater.

Direct Venting

The water heater uses 2 in or 3 in diameter exhaust and 2 in or 3 in diameter intake air ducts. To ensure the draw of air directly from and exhaust of air directly to the outside of the building, create an airtight seal from the water heater collar to the vent termination.

Intake materials can be made of ABS, PVC, CPVC, PP, galvanized steel, corrugated aluminum or any other such materials. If you use a corrugated material, ensure that there is not inadvertent crimping of, or damage to, the intake air pipe.

When using direct venting, maintain the following venting clearances, as required by **ANSI Z21.10.3 and the National Fuel Gas Code, ANSI Z223.1/NFPA 54, and CAN/CGA B149.1 Natural Gas and Propane Installation Code:**

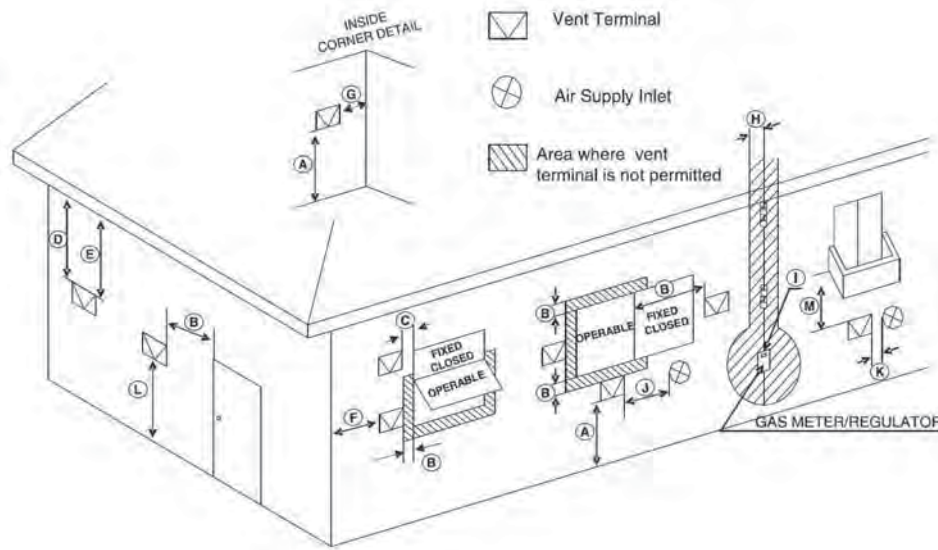

Ref	Description	Canadian Direct Vent Installations ¹	US Direct Vent Installations ²
A	Clearance above grade, veranda, porch, deck, or balcony	12 in (30 cm)	12 in (30 cm)
B	Clearance to window or door that may be opened	36 in (91 cm)	12 in (30 cm)
C	Clearance to permanently closed window	*	*
D	Vertical clearance to ventilated soffit located above the terminal within a horizontal distance of 2 ft (61 cm) from the center line of the terminal	*	*
E	Clearance to unventilated soffit	*	*
F	Clearance to outside corner	*	*
G	Clearance to inside corner	*	*
H	Clearance to each side of center line extended above meter/regulator assembly	3 ft (91 cm) within a height 15 ft above the meter/regulator assembly	*
I	Clearance to service regulator vent outlet	3 ft (91 cm)	*
J	Clearance to nonmechanical air supply inlet to building or the combustion air inlet to any other appliance	36 in (91 cm)	12 in (30 cm)
K	Clearance to a mechanical air supply inlet	6 ft (1.83 m)	3 ft (91 cm) above if within 10 ft (3 m) horizontally
L	Clearance above paved sidewalk or paved driveway located on public property	7 ft (2.13 m) †	*
M	Clearance under veranda, porch deck, or balcony	12 in (30 cm) ‡	*

¹ In accordance with the current CSA B149.1 Natural Gas and Propane Installation Code

² In accordance with the current ANSI Z223.1 / NFPA 54 National Fuel Gas Code

† A vent shall not terminate directly above a sidewalk or paved driveway that is located between two single family dwellings and serves both dwellings.

‡ Permitted only if veranda, porch, deck, or balcony is fully open on a minimum of two sides beneath the floor.

* Clearance in accordance with local installation codes and the requirements of the gas supplier.

Non-Direct Venting (Single Pipe)

If, at any time, the installation location could experience negative pressure, there is a possibility of back drafting cold air through the water heater’s heat exchanger. This situation could lead to the freezing of the heat exchanger and malfunction of the water heater.

However, building codes in most jurisdictions disallow negative pressures in residences. In a home with a well-balanced air supply, the heat exchanger should not be in danger of freezing. Because the cause of back drafting is not considered a manufacturing problem, any freezing damage which occurs from back drafting will not be covered by the Navien warranty. If there is any question about the possibility of back drafting in the installation location, use a direct venting system for the water heater.

When installed in a manufactured home (mobile home), all combustion air must be supplied from the outdoors as described on page 28.

When using non-direct venting, maintain non-direct vent clearances shown on page 32 as required by **ANSI Z21.10.3 and the National Fuel Gas Code, ANSI Z223.1/NFPA 54, and CAN/CSA B149.1 Natural Gas And Propane Installation Code.**

To use non-direct venting for the water heater:

1. Insert the termination end cap into the intake air duct. Do not glue the end cap, to allow for easy removal and cleaning of the cap.

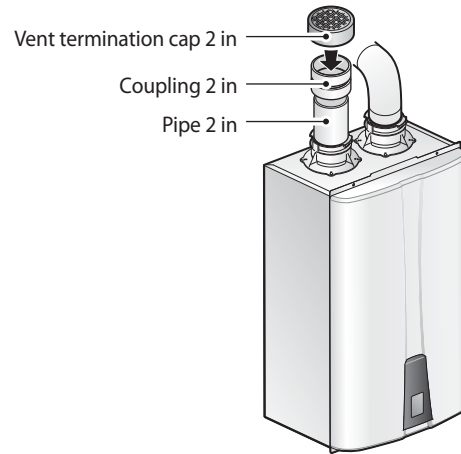

2. Provide two openings to allow for circulation of combustion air as specified by ANSI Z223.1/NFPA 54 or CAN/CGA B-149.1:

	Maximum Input (BTU/H)	Outdoor make up air is provided, a minimum free area of 1 in ² , per 4,000 BTU/H	Indoor make up air is provided, a minimum free area of 1 in ² per 1,000 BTU/H
NPE-150S	120,000	30 in ² 10 in (W) x 3 in (H) or 6 in round	120 in ² 11 in (W) x 11 in (H)
NPE-180A NPE-180S	150,000	40 in ² 10 in (W) x 4 in (H) or 7 in round	150 in ² 12 1/4 in (W) x 12 1/4 in (H)
NPE-210A NPE-210S	180,000	45 in ² 10 in (W) x 5 in (H) or 8 in round	180 in ² 13 1/4 in (W) x 13 1/4 in (H)
NPE-240A NPE-240S	199,900	50 in ² 10 in (W) x 5 in (H) or 8 in round	199 in ² 14 1/4 in (W) x 14 1/4 in (H)

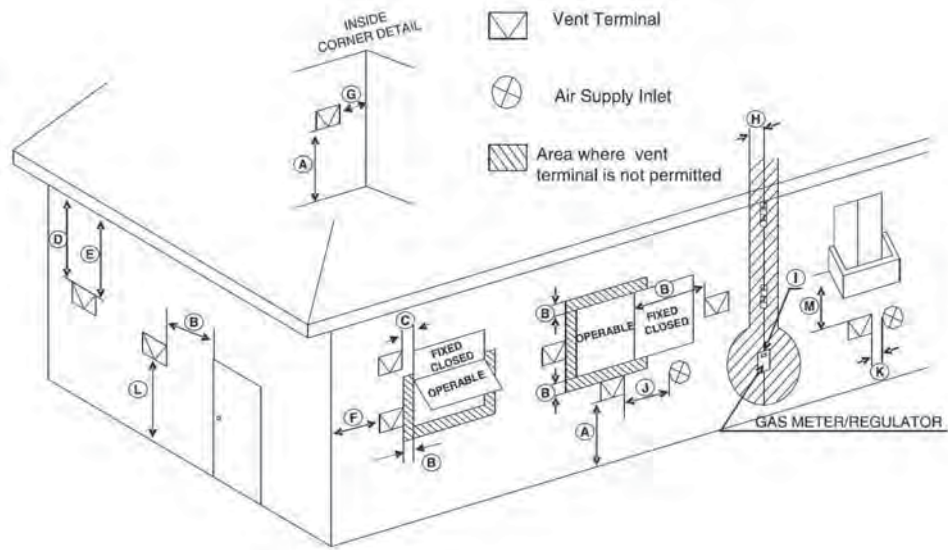

Ref	Description	Canadian Non-Direct Vent Installations ¹	US Non-Direct Vent Installations ²
A	Clearance above grade, veranda, porch, deck, or balcony	12 in (30 cm)	12 in (30 cm)
B	Clearance to window or door that may be opened	36 in (91 cm)	48 in (120 cm) below or to side of opening; 12 in (30 cm) above opening
C	Clearance to permanently closed window	*	*
D	Vertical clearance to ventilated soffit located above the terminal within a horizontal distance of 2 ft (61 cm) from the center line of the terminal	*	*
E	Clearance to unventilated soffit	*	*
F	Clearance to outside corner	*	*
G	Clearance to inside corner	*	*
H	Clearance to each side of center line extended above meter/regulator assembly	36 in (91 cm) within a height 15 ft (4.57 m) above the meter/regulator assembly	*
I	Clearance to service regulator vent outlet	36 in (91 cm)	*
J	Clearance to nonmechanical air supply inlet to building or the combustion air inlet to any other appliance	36 in (91 cm)	48 in (120 cm) below or to side of opening; 12 in (30 cm) above opening
K	Clearance to a mechanical air supply inlet	6 ft (1.83 m)	36 in (91 cm) above if within 10 ft (3 m) horizontally
L	Clearance above paved sidewalk or paved driveway located on public property	7 ft (2.13 m) †	*
M	Clearance under veranda, porch deck, or balcony	12 in (30 cm) ‡	*

1 In accordance with the current CSA B149.1 Natural Gas and Propane Installation Code

2 In accordance with the current ANSI Z223.1 / NFPA 54 National Fuel Gas Code

† A vent shall not terminate directly above a sidewalk or paved driveway that is located between two single family dwellings and serves both dwellings.

‡ Permitted only if veranda, porch, deck, or balcony is fully open on a minimum of two sides beneath the floor.

* Clearance in accordance with local installation codes and the requirements of the gas supplier.

3.6.2 Selecting Vent Pipe Materials

Venting requirements differ in the US and Canada. Consult the following chart or the most recent edition of ANSI Z223.1/ NFPA 54 or CAN/CGA B149.1, as well as all applicable local codes and regulations when selecting vent pipe materials. Do not use cellular core PVC (ASTM F891), cellular core CPVC, Radel® (polyphenolsulfone) for the exhaust vent.

Locale	Recommended Vent Materials
USA	<ul style="list-style-type: none"> • PVC Schedule 40 (Solid Core) • CPVC Schedule 40 or 80 (Solid Core) • Approved Polypropylene*
Canada**	<ul style="list-style-type: none"> • Type BH Special Gas Vent Class IIA (PVC) • Type BH Special Gas Vent Class IIB (CPVC) • Type BH Special Gas Vent Class IIC (Polypropylene)

* Approved polypropylene systems include:
 Duravent Polypro (Single Wall): 2PPS-xxx (2 in), 3PPS-xxx (3 in)
 Centrotherm Innoflue SW: ISxx02xx (2 in), ISxx03xx (3 in)
 Centrotherm Innoflue Flex: IFVL02XXX (2 in)

Refer to the manufacturer's literature for detailed information.

**For installation in Canada, field-supplied plastic vent piping must comply with CAN/CGA B149.1 (latest edition) and be certified to the Standard For Type BH Gas Venting Systems, ULC-S636. Components of this listed system must not be interchanged with other vent systems or unlisted pipes or fittings. All plastic components and specified primers and glues of the certified vent system must be from a single system manufacturer and must not be intermixed with another system manufacturer's parts. The supplied vent connector and vent termination are certified as part of the water heater.

CAUTION

- This water heater has a built-in control to limit the exhaust temperature to 149°F (65°C). As a result, the Navien water heater can be vented with Schedule 40 PVC. If the incoming (or recirculation return) water temperature does not exceed 150°F (66°C), the exhaust temperature will not exceed 149 °F (65 °C).
- However, if you set the water heater at a temperature above 150 °F (66 °C) and you are also incorporating either an external recirculation loop or a combination heating system, the exhaust temperature can exceed 149 °F (65 °C). In that case, you must use Schedule 40 or 80 CPVC or Approved Polypropylene in the USA or Type BH Special Gas Vent Class IIB (CPVC) or Class IC (Polypropylene) that conforms to ULC-S636 in Canada.
- In systems with 2 in vents, if the exhaust temperature exceeds 149 °F (65 °C), CPVC pipe (field supplied) must be used for the first 3 ft of equivalent pipe length. For systems with 3 in vents, if the exhaust temperature exceeds 149 °F (65 °C), CPVC pipe (field supplied) must be used for the first 5 in of equivalent pipe length.

Example of a Centrotherm Innoflue® Flex (2 in) Vent System*

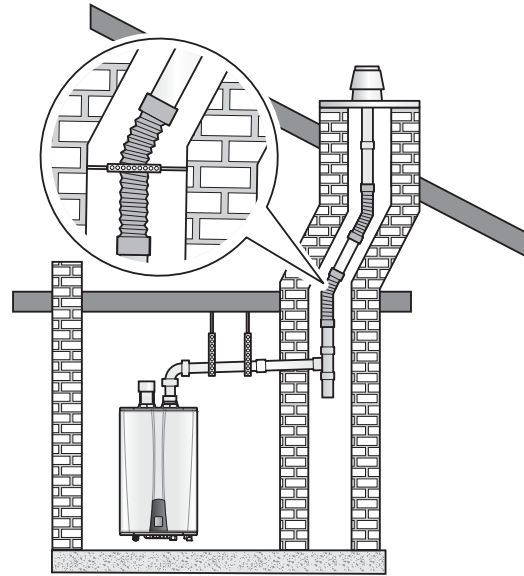

* VERTICAL installations only. Horizontal termination is not allowed.

The following table lists the model types approved for use with the Centrotherm Innoflue® Flex 2 in vent pipes, and the maximum length of the vent system.

Model type	NPE-150S	NPE-180A/S	NPE-210A/S
Max. length	50 ft	50 ft	50 ft

- Use of flexible vent pipes is not approved for any other models that are not listed in the table.
- All flexible vent pipe must be installed VERTICALLY through the roof. No horizontal terminations are permitted.
- Use a 2 in snap fit coupler or the Innoflue® Single Wall Residential vent pipes to connect the Innoflue® Flex 2 in vent pipes to the exhaust.
- After installation, ensure that the vent system is tightly sealed at the joints.
- All installation using the flexible vent materials must be in INDIRECT VENTING only.

Refer to the manufacturer's literature for detailed information.

3.6.3 Measuring Vent Length

The maximum vent length when using 2 in exhaust ducts is 60 ft. The maximum vent length when using 3 in vent ducts is 150 ft. The intake duct length can be of equal length to the exhaust duct length. Both maximum lengths are reduced by the number of elbows used, as shown in the following table:

Vent Size	Maximum Length	Maximum # of Elbows	Equivalent Lengths
2 in	60 ft (18 m)	6	Reduce the maximum vent length accordingly for each elbow used: <ul style="list-style-type: none"> • Each 90° elbow equates to 8 linear ft (2.4 m) of vent • Each 45° elbow equates to 4 linear ft (1.2 m) of vent
3 in	150 ft (45 m)	8	Reduce the maximum vent length accordingly for each elbow used: <ul style="list-style-type: none"> • Each 90° elbow equates to 5 linear ft (1.5 m) of vent • Each 45° elbow equates to 3 linear ft (0.9 m) of vent

Note

- The Maximum Length does not include any elbows.
- If using a concentric termination as shown on pages 34-36, count this as 5 linear ft (1.5 m) of vent.
- The maximum vent lengths at high altitudes are the same as shown in the table above.

3.6.4 Terminating the Vent

Before installing the water heater, determine what type of vent termination is appropriate for the installation location and situation. Examples in this section describe typical venting configurations, but they do not include all possible options.

Along with 2 in and 3 in PVC Concentric Terminations shown on pages 35-36, the following terminations can also be used:

- IPEX Low Profile Termination Kits:
 - 2 in Low Profile Vent Kit #196984
 - 3 in Low Profile Vent Kit #196985
- Duravent PolyPro Horizontal Concentric Termination Kit
 - 2 in x 4 in Concentric Vent Kit #2PPS-HK
 - 3 in x 5 in Concentric Vent Kit #3PPS-HK

Refer to the vent manufacturer's instructions for detailed installation procedures.

Indoor Water Heater Installation Venting Examples

The following are some possible indoor venting options:

- 2 in or 3 in Two-pipe Sidewall Venting

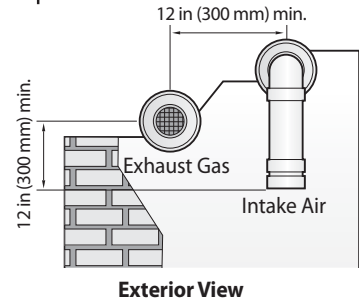
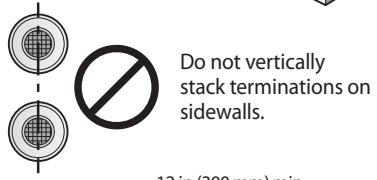
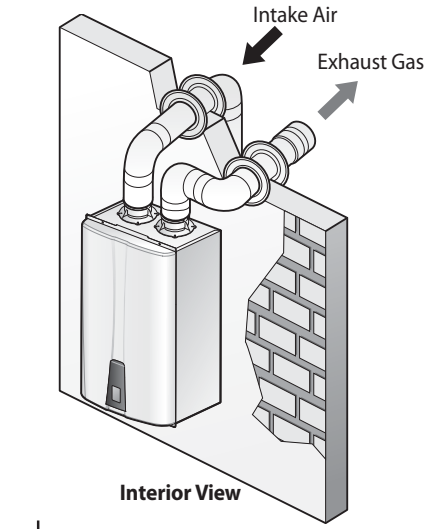

- Non-concentric Sidewall Venting – Air is drawn from a different location at a minimum of 12 in (300 mm) from the exhaust termination. Try to minimize the length of the intake air pipe with this venting.

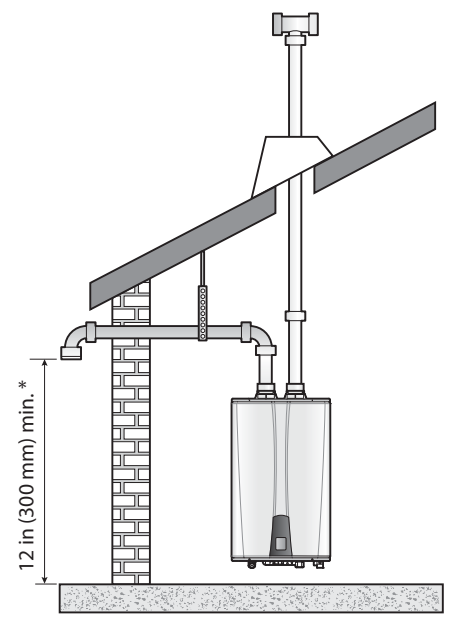

* 12 in (300 mm) above the highest anticipated snow level, or as required by local codes, whichever is greater

- Concentric Sidewall Venting

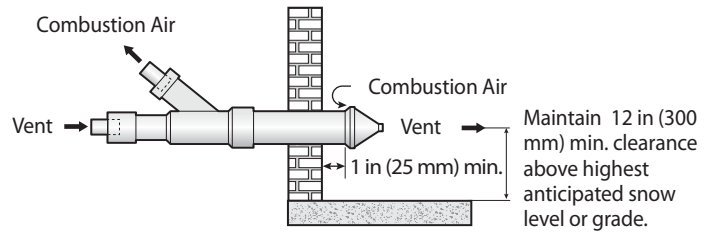

CAUTION

Refer to the figures below for the orientation of vent if the IPEX low profile vent kit if it is used for termination.

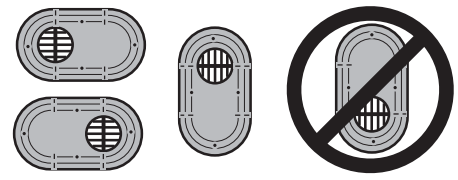

- 2 in or 3 in Two-pipe Vertical Venting – Intake and exhaust pipes do not have to terminate in the same area.

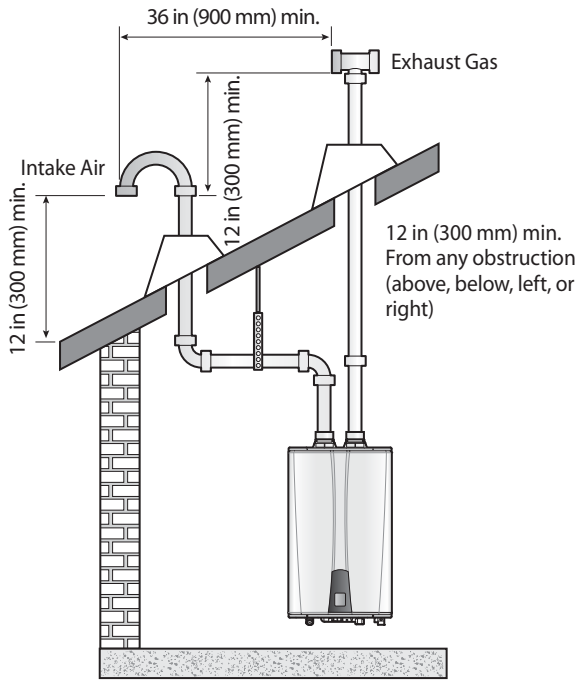

- Concentric Roof Venting

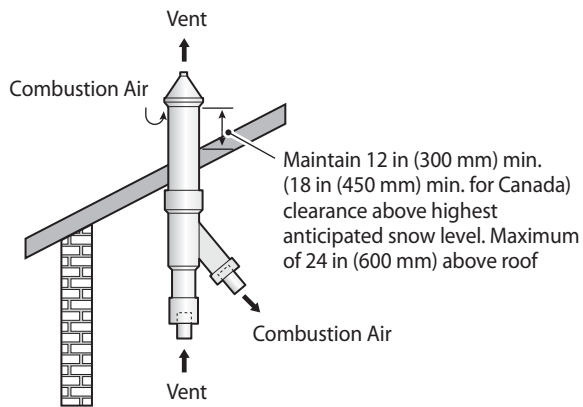

Outdoor Installation

Outdoor installation should only be considered in mild climates. Freezing temperatures or contaminated air can damage the water heater. When installing the water heater outdoors, maintain clearances from building openings, as described in the “Non-Direct Venting (Single Pipe)” section on page 31. Outdoor installation areas should be in an open, unroofed area and should allow for the following minimum clearances from the water heater:

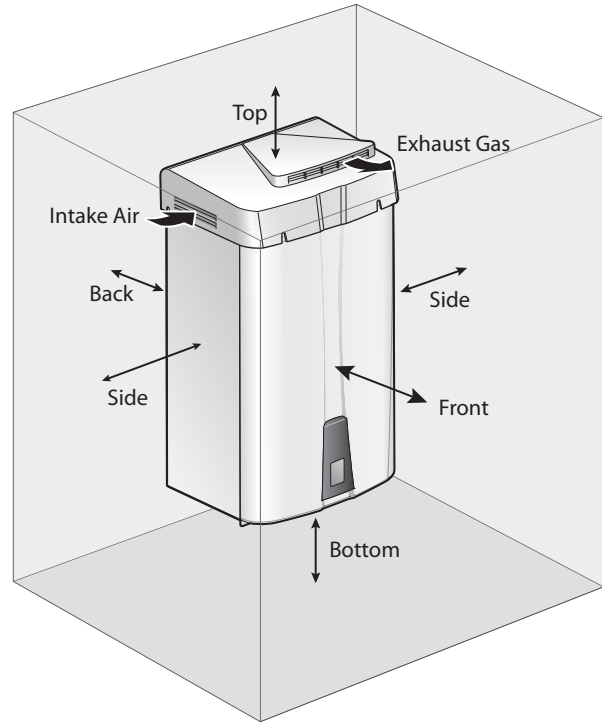

Bottom	12 in
Back	0.5 in
Sides	3 in
Front	24 in
Top	36 in

When installing a water heater outdoors, follow these guidelines:

- The Navien Outdoor Vent Kit must be used to ensure proper operation of the water heater.
- Ensure that there is plenty of clearance around the air intake and that it is adequately protected to prevent any debris, liquids, or flammable gases from entering the air intake.
- If the water heater is installed under an eave, maintain a clearance of 3 ft or more from the eave to the top of the water heater vent terminals.

3.7 Connecting the Power Supply



WARNING

Improperly connecting the power supply can result in electrical shock and electrocution. Follow all applicable electrical codes of the local authority having jurisdiction. In the absence of such requirements, follow the latest edition of **the National Electrical Code (NFPA 70) in the USA or the latest edition of CSA C22.1 Canadian Electrical Code Part 1 in Canada**. Connecting the power supply should be performed only by a licensed professional.

When connecting the power supply, follow these guidelines:

- Do not connect the electric supply until all plumbing and gas piping is complete and the water heater has been filled with water.
- Do not connect the water heater to a 220-240 V AC power supply. Doing so will damage the water heater and void the warranty.
- All water heaters come with a factory-installed, 3-pronged (grounded) plug. The water heater can be plugged into any grounded electrical outlet nearby, as it requires only 2-4 Amps. It is not necessary to run a dedicated electrical line to the water heater.
- If local codes require the water heater to be wired directly, remove and discard the factory-installed plug. Install a power switch between the breaker and the water heater to facilitate end-user maintenance and servicing. Connect the water heater to a 110-120 V AC at 60 Hz with a maximum of 2 A (4 A if an external pump is connected) rating electrical supply.
- The water heater must be electrically grounded. If using the power plug, ensure that the electrical outlet you connect the water heater to is properly grounded. If wiring the water heater directly to a power supply, do not attach the ground wire to either the gas or the water piping as plastic pipe or dielectric unions may prevent proper grounding.
- We recommend using a surge protector to protect the water heater from power surges.
- If there is a power failure in cold weather areas, the freeze prevention system in the water heater will not operate and may result in freezing of the heat exchanger. In cold weather areas where power failures are common, you must completely drain the water heater to prevent damage if the power will be off for any extended period of time. A battery back-up (available at most computer retailers) may be used to supply hot water during periods of power outages. Damage caused by freezing is not covered under warranty.

3.8 Setting the DIP Switches

The water heater has two DIP switch locations: on the main circuit board (PCB) and on the front panel. Each location has two sets of DIP switches that control the functionality of the water heater. Set the DIP switches appropriately, based on the installation environment.

3.8.1 Circuit Board DIP Switches

The two sets of DIP switches on the circuit board configure the water heater's model settings. These configurations are set at the factory and should not be changed.

3.8.2 Setting the Front Panel DIP Switches

The two sets of DIP switches on the front panel configure the water heater's pump & recirculation, display, well pump, storage tank & solar system, lime alarm, high altitude, cascade venting and gas type settings. Some of these configurations are set at the factory and should not be changed. The following tables describe the functions of the DIP switches and their settings:

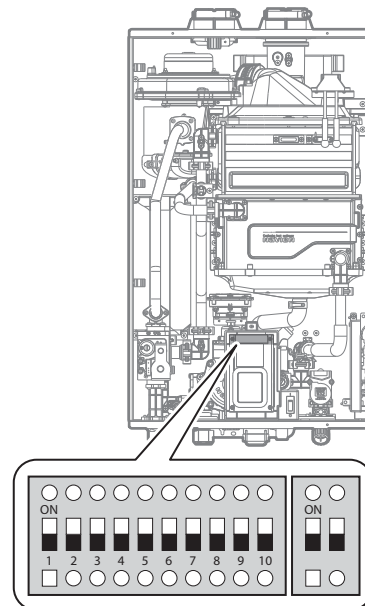

• 10-switch Panel:

Switch	Function	Setting	Remark
1-3	Recirculation Mode- Internal Navien Pump ("A" model only)	No Recirculation	1-OFF; 2-OFF; 3-OFF
		Internal Recirculation	1-ON; 2-OFF; 3-OFF
		External Recirculation	1-OFF; 2-ON; 3-OFF
		Intelligent Preheating*	1-ON; 2-ON; 3-OFF
	Recirculation Mode- External Pump Connected**	External Pump Only	1-OFF; 2-OFF; 3-ON
		Internal Recirculation ("A" model only)	1-ON; 2-OFF; 3-ON
		External Recirculation ("A" model only)	1-OFF; 2-ON; 3-ON
		Intelligent Preheating*	1-ON; 2-ON; 3-ON
4	Display Temperature Unit	Celsius	4-ON
		Fahrenheit	4-OFF
5	Well Pump	Well Pump Operation	5-ON
		Do Not Use Well Pump	5-OFF
6	DHW Storage Tank/ Solar System	Storage Tank/Solar System Operation	6-ON
		Do Not Use Storage Tank/Solar System	6-OFF
7 & 8	Lime Alarm***	6 Months Alert	7-ON; 8-OFF
		12 Months Alert	7-OFF; 8-ON
		24 Months Alert	7-ON; 8-ON
9 & 10	High Altitude ****	0–1,999 ft (0–609 m)	9-OFF, 10-OFF
		2,000–5,399 ft (610–1,645 m)	9-ON, 10-OFF
		5,400–7,699 ft (1,646–2,346 m)	9-OFF, 10-ON
		7,700–10,100 ft (2,347–3,078 m)	9-ON, 10-ON

***Intelligent Preheating:**
Learns the user's hot water usage patterns and starts preheating prior to an anticipated draw.

- Preheating starts when remote controller is not connected.
- When remote controller is connected, preheating starts and operates based on the timer.
- Set the timer on the remote controller to use hot water at the time of your choice.
- Intelligent preheating does not function in Cascade Mode (Preheating OFF).
- Freeze protection is still available with preheating OFF.

****External Pump:**
These settings are to be used when an external pump is wired to the water heater.

*****Lime Alarm:**
Displays a "760" error when the set time period has been reached to indicate a flush or service is necessary.

******High Altitude**
Above 2,000 ft (610 m), the water heater will de-rate by 4% for each 1,000 ft (305 m) of altitude gain.

Note

This water heater may be installed at elevations up to 10,100 ft (3,078 m) for use with Natural Gas and 4,500 ft (1,370 m) for use with Propane. To use the water heater at a specific altitude, the DIP switches should be set as described above.



CAUTION

Do not configure the system for DHW recirculation when it is configured to run an air handler using the H2Air controller. DHW recirculation and Navien H2Air configurations cannot be used at the same time.

• 2-switch Panel:

Switch	Function	Setting	
1	Cascade Vent	Common Vent	1-OFF
		Individual Vent	1-ON
2	Gas Type	Natural Gas	OFF
		Propane Gas	ON

4. Installing a Cascade System

When installing a cascade system, carefully consider the design of the system and the features of the installation location. Follow all local codes and regulations, as well as all guidelines for installing the water heater. The following sections describe additional considerations that are specific to installing cascade systems. Read them carefully before designing or installing the system.

4.1 Connecting Water Supplies

Several options are available for plumbing a cascade system of water heaters. The options shown here are only examples. The setup you choose will vary based on the installation location, local building codes, and other factors. Follow all applicable regulations when installing a cascade system.

You can connect up to 16 water heaters to meet high-volume hot water demands. Some possible connection options include the following:

- Recirculation via Internal Pumps ("A" model only):

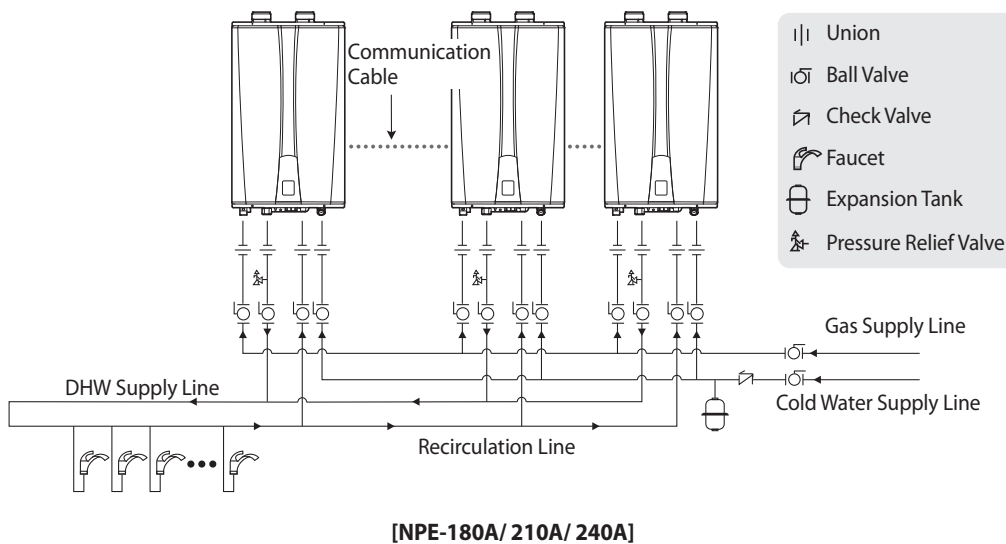

Note

The recommended minimum recirculation flow rate for each water heater is 2 GPM. Depending on the number of water heaters and the diameter of the recirculation line, it may not be necessary to connect all water heaters to the recirculation line. If this is the case, set the unconnected water heaters to internal recirculation mode. The master water heater must always be connected to the recirculation line and set to external recirculation mode.

- Multiple NPE-S Units:

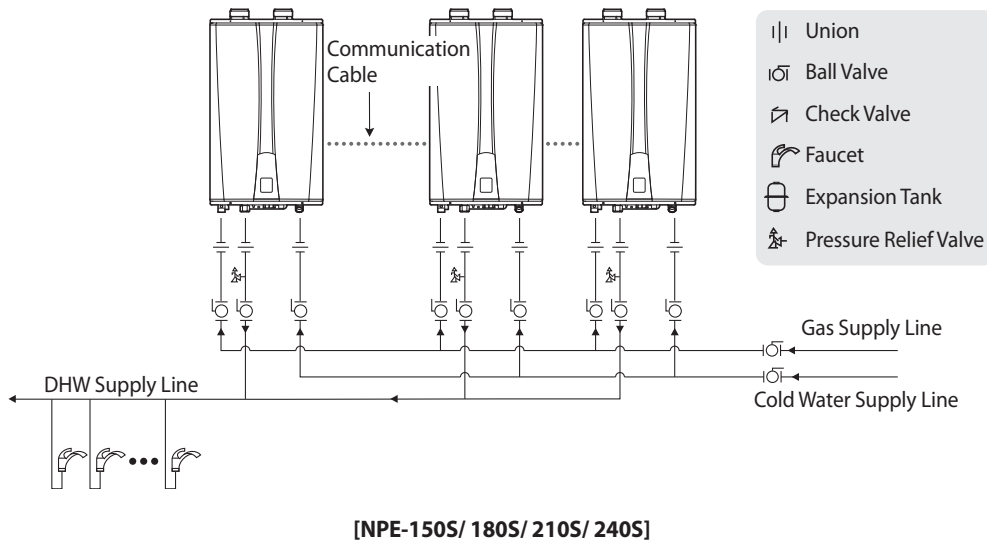

4.1.1 Piping Sizes and Considerations

When plumbing a cascade system, consider the following pipe diameters and flow rates. Note that flow rates above 6.6 ft/s may cause pipe erosion. These specifications may vary depending on installation conditions.

Qty	$\Delta T=54^{\circ}\text{F}$ Flow rate (GPM)	Water Velocity (ft/s)	Pipe Diameter (mm/in)	
1	7.19	4.78	20A	3/4 in
2	14.38	5.61	25A	1 in
3	21.57	5.54	30A	1 1/4 in
4	28.77	5.21	40A	1 1/2 in
5	35.96	6.53	40A	1 1/2 in
6	43.15	4.49	50A	2 in
7	50.34	5.24	50A	2 in
8	57.5	6.00	50A	2 in
9	64.72	4.39	65A	2 1/2 in
10	71.92	4.75	65A	2 1/2 in
11	79.11	5.34	65A	2 1/2 in
12	86.30	5.84	65A	2 1/2 in
13	93.49	6.33	65A	2 1/2 in
14	100.68	6.79	65A	2 1/2 in
15	107.87	5.11	80A	3 in
16	115.07	5.44	80A	3 in
17	122.26	5.81	80A	3 in
18	129.45	6.14	80A	3 in
19	136.64	6.46	80A	3 in
20	143.83	6.83	80A	3 in
21	151.02	4.06	100A	4 in
22	158.21	4.25	100A	4 in
23	165.41	4.45	100A	4 in
24	172.60	4.65	100A	4 in
25	179.79	4.85	100A	4 in
26	186.98	5.05	100A	4 in
27	194.17	5.24	100A	4 in
28	201.36	5.44	100A	4 in
29	208.56	5.61	100A	4 in
30	215.75	5.81	100A	4 in

Note The table above is based on model NPE-240A.

4.2 Connecting the Communication Cables

Up to 16 water heaters can be connected with Navien Ready-Link communication cables. Select one of the water heaters in the cascade system as the master water heater, and then connect the other water heaters to it as slaves. Before making any connections, ensure that the power is turned off to all water heaters.

Connect the Ready-Link cables to the J6 ports on the right side of the front panel:

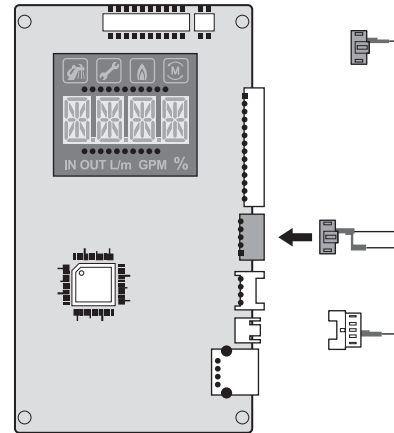

4.2.1 Configuring the Communication Settings

After connecting the Ready-Link communication cables, restore power to the water heater and turn on all water heaters using the Power button.

To configure the communication settings:

1. On the master water heater, press and hold the **Diagnostic** and **Up(+)** buttons for more than 5 seconds. "MA.00" will appear on the display to confirm that this water heater is set as the master.

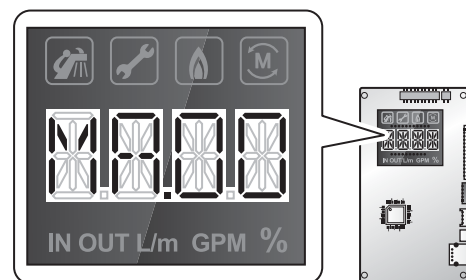

2. On the slave water heater, press and hold the **Diagnostic** and **Down(-)** buttons for more than 2 seconds. "SL.01" will appear on the display to confirm that this water heater is set as a slave.

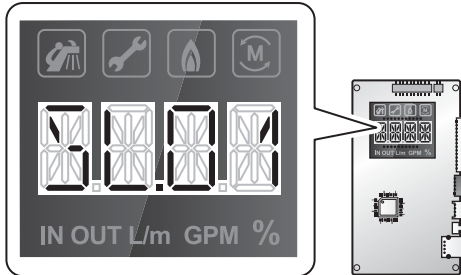

3. Repeat step 2 to configure the rest of the slave water heaters in the system.
4. On the master water heater, press and hold the **Diagnostic** and **Up(+)** buttons for more than 5 seconds. All the display screens on the configured water heaters will return to the temperature display.

Note

- To add additional slaves at a later time, repeat step 2.
- To cancel the cascade communication setup, on the master water heater, press and hold the **Diagnostic** and **Reset** buttons for more than 5 seconds. The water heaters will revert to independent operation. Repeat steps 1-4 to reassign the master water heater.

5. Installing a Common Vent System

About the Common Vent System

The Navien Common Vent System* provides an easy way to install the vent system for up to 8 Navien NPE water heater units. By sharing the main intake and exhaust vent pipes, effective system venting is available with less venting materials and minimal number of penetrations on the walls or roofing.

* Independently tested and approved by CSA

Read all safety messages and carefully follow the guidelines in this manual when installing a common vent system for the Navien NPE water heater units.



WARNING

Improper venting of the water heater units can result in excessive levels of carbon monoxide, which can lead to severe personal injury or death. **The water heater units must be vented in accordance with the "Venting of Equipment" section of the latest edition of the ANSI Z223.1/NFPA 54 Natural Fuel Gas Code in the USA, as well as all applicable local building codes and regulations.** Follow all instructions and guidelines when venting the water heater units. Venting should be performed only by a licensed professional.

Guidelines for a Common Vent System



CAUTION

- To ensure the correct operation of the common vent system,
 - a cascade communication cable **MUST** be installed between all units in the common vent system by the installer.
 - backflow vent dampers must be installed in the exhaust duct of each water heater unit.
 - **use direct vent systems** (with separate intake and exhaust lines).
- This section covers the installation of a common vent system for **NPE water heaters only**.

To ensure the safe and correct installation of the common vent system, carefully follow the instructions and guidelines.

- Check to see if all contents are included in the package (refer to the "Included Items" on page 46).
- A maximum of 8 NPE water heaters may be connected to one common vent system. In a cascade system that has more than 8 water heaters, use 2 common vent systems, or consult Navien.
- Use only the PVC cements specified in this manual when connecting pipes, joints, or elbows.
- Position the water heater units as close as possible to the vent termination.
- Install a new vent system with this appliance. If an existing vent system is reused, thoroughly inspect it for punctures, cracks, or blockages prior to connecting it to the water heater unit.
- The common vent system covered in this manual is approved only for direct venting applications.
- Horizontal vent pipe runs must be supported every 4 feet (1.2 m) (minimum). All vertical vent pipe runs must be supported every 6 feet (1.8 m) (minimum). Support the vent pipe with hangers at regular intervals or as required by local codes.
- Install a backflow damper for each water heater unit. Use only the damper specified in this manual.
- To avoid moisture and frost build-up and to maintain clearances to openings on adjacent homes, 45° elbows, 90° elbows, or tees may be attached to the end of the termination vent pipe to direct the exhaust plumes away from buildings, as long as the total allowable vent lengths, maximum number of elbows, and distances to air intake restrictions are observed.
- If the water heater units will be installed in areas where snow is known to accumulate, protect the vent termination from blockage. Provide a minimum of 1 foot (30 cm) clearance from the bottom of the exhaust of the expected snow accumulation level. Snow removal may be necessary to maintain clearance.
- Ensure that the vent termination is at least 12 in (305 mm) above ground, 12 in (305 mm) above the highest anticipated snow level, or as required by local codes, whichever is greater.
- Support the vent pipe with hangers at regular intervals or as required by local codes.
- The vent for this appliance shall not terminate over public walkways; or near soffit vents or crawl space vents or where condensate or vapor could create a nuisance or hazard or cause property damage; or where condensate or vapor could cause damage or could be detrimental to the operation of regulators, relief valves, or other equipment.

Clearances Between Multiple Units

Ensure that the installed water heaters satisfy all installation clearances provided in the manual. It is essential that there is sufficient clearance space for the common vent system to work properly.

The water heater units can be mounted either IN-LINE or BACK TO BACK.

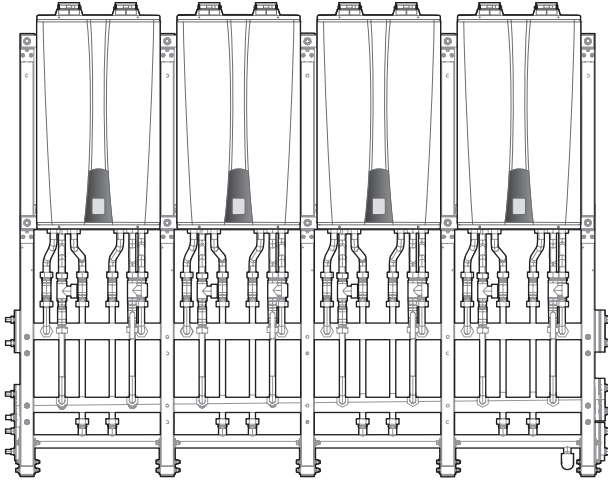

Navien Modular Configuration with Rack System

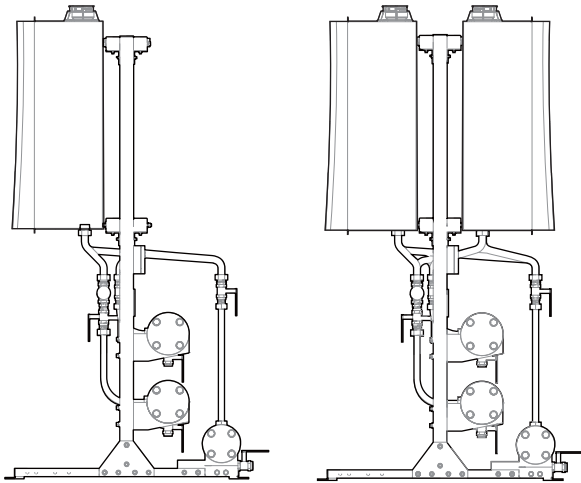

In-line Setup

Back to Back Setup

<Clearance Chart for Common Vent Applications>

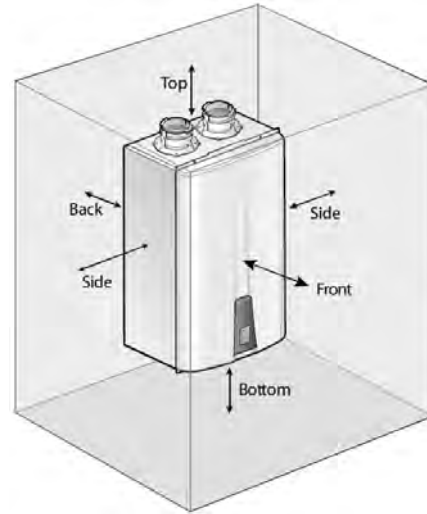

Bottom	12" (300 mm)
Back	0.5" (13 mm)
Side	3" (76 mm)
Front	24" (609 mm)
Top	36" (914 mm)

General and Local Standards Information

When installing and operating the common vent system, the following standards and regulations must be complied with and adhered to:

- Local codes or, in the absence of local codes, the National Fuel Gas Code, ANSI Z223.1/NFPA 54.
- Appliance manufacturer's Installation Instructions.
- Regulations on the supervision of construction.
- Statutory provisions.
- Installation and service work must be carried out by licensed professionals only.

Risk Guidelines

- Ensure that all common vent system components are manufactured and installed in accordance with valid standards, regulations, and safety engineering rules.
- To avoid risk, the common vent system must be installed and used only for the original purpose described in this manual.
- Defects or damages found in a common vent system must be addressed and repaired immediately.
- For roof or chimney modifications, refer to the relevant industrial safety regulations.
- Works on roofs and facades are dangerous. Comply with all relevant regulations.

Cutting and Assembling Common Vent System

Components

Standard tools are suitable for the cutting and assembly of common vent system components. Follow the guidelines listed below when working with the components.

- When cutting vent components, ensure that the cuts are straight. Chamfer and deburr all edges before installing the components.
- All vent joints must be fully tightened.
- Before operating the system, ensure that the installed vent system is clean and free of debris.
- Ensure that the vent system is rigidly supported according to the manual's instructions.

Selecting Vent Pipe Materials

Consult the following chart or the most recent edition of ANSI Z223.1/NFPA 54, as well as all applicable local codes and regulations when selecting vent pipe materials. This appliance should be vented with materials approved for Category IV gas appliances. Do not use cellular core PVC (ASTM F891), cellular core CPVC, or Radel® (polyphenolsulfone) for the exhaust vent. See below for recommended vent materials.

Locale	Recommended Vent Materials
USA	<ul style="list-style-type: none">• PVC Schedule 40 (Solid Core)• CPVC Schedule 40 or 80 (Solid Core)

Vent Pipe Pitch and Supports

For horizontal runs, slope the horizontal section upward toward the vent termination at a rate of 1/4" per foot (2% slope).

Connecting Pipes with Cement

! CAUTION

The vapors from primers and solvent cements can make you dizzy and are dangerous to your health. Ensure that the work area is well ventilated, or wear an approved organic vapour respirator when working with primers and solvent cements.

To connect the vent pipes using cement:

1. Spread an even layer of solvent cement on the inside of the pipe fitting and the outside of the pipe.

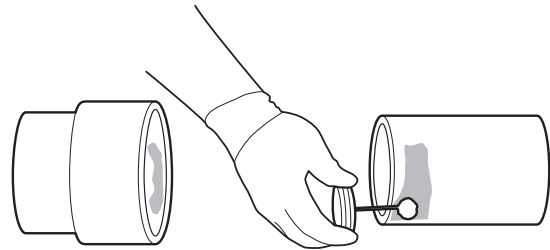

2. Align the pipe with the pipe fitting and twist the pipe a quarter turn as you insert it into the fitting. Twisting the pipe spreads the solvent cement evenly to ensure a solid joint.

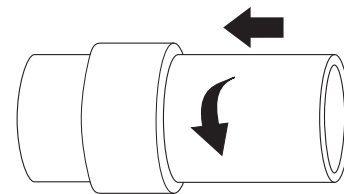

3. Hold the pipe and pipe fitting together for about 15 seconds until the cement sets.

Note

- Use approved solvent type cement for the proper vent materials.
- Use solvent type cement only.
- Check the date of manufacture before using the cement. Ensure that cement was not manufactured more than 2 years prior to using it.
- Ensure that the inside of the pipe fitting and the outside of the pipe, where cement will be applied, is clean.
- Apply an even layer of cement over all mating surfaces.
- Use solvent cement in room temperatures higher than 32°F (0°C).
- Installing vent pipe with cement in cold ambient temperatures can result in longer cure times.



DANGER

Be careful not to apply force or impact to pipes after making connections. An impact may break the bond and harmful gas might leak inside the room.

Determining the Length of a Common Vent System

Follow the instructions listed below to determine the length of a common vent.

1. Add the BTU/H input ratings for each unit in the cascading system to determine the total BTU/H rating.
2. Determine the total length (L) of the common vent, which consists of the horizontal width (W) and the vertical height (H):
Total length (L) = W + H.

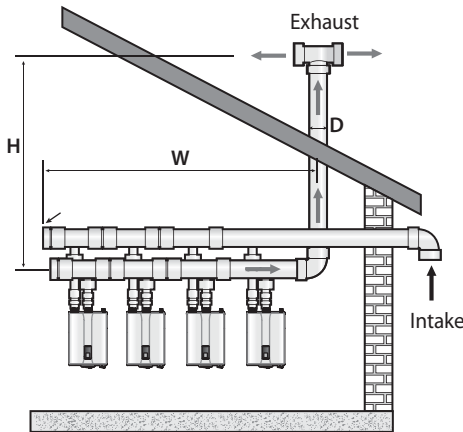

Common Vent Length Table [Total Length (L) = W + H]

Vent Length for NPE Water Heater Units

Required Load (Total BTU/H)	Model	Total Length (ft)			
	NPE-240A/S	D=3"	D=4"	D=6"	D=8"
399,800	2	60	106	200	
599,700	3	40	71	160	
799,600	4	30	53	120	
999,500	5			96	150
1,199,400	6			80	142
1,393,300	7			68	121
1,599,200	8			60	106

Note

Every 90° elbow used is equivalent to 8 linear feet (2.4 m) of vent length.

Example of a Typical Installation (Direct Vent Only)

The following illustration depicts an example of a common vent system installed for a cascade system of 8 Navien NPE heater units.

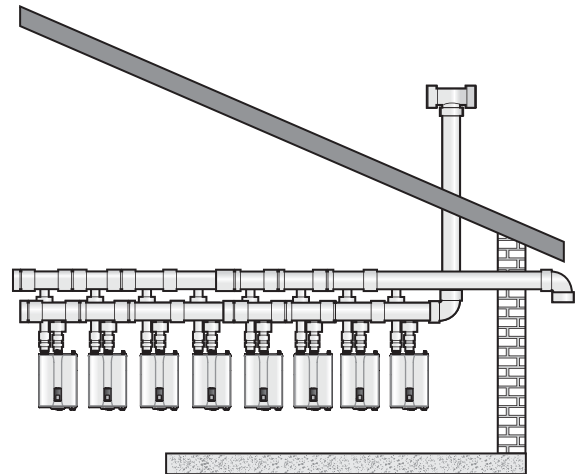

Note

The illustration is intended for reference purposes only.



Navien Backflow Damper (Back-draft Damper)

The Navien backflow damper prevents backflow (back-draft) at the exhaust vent while the water heater unit operates.

By closing the exhaust vent as soon as the combustion cycle ends, the Navien backflow damper retains heat in the system for longer periods. This improves the system's thermal efficiency.

Note When using a common vent in a cascade system, backflow devices are required to prevent exhaust from entering the building.

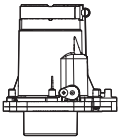
Included Items

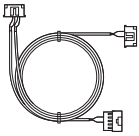
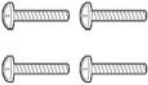
Backflow Damper	
Installation Manual	
Ready-Link communication cable	
Screw (4 ea)	

Specifications

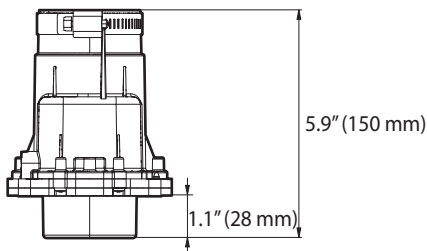

Part Name	Backflow Damper
Part No.	30014367A
Material	PP (Polypropylene)

Maintenance Port

Navien Backflow Damper has a maintenance port to allow you to easily inspect the operating condition of the damper plate.

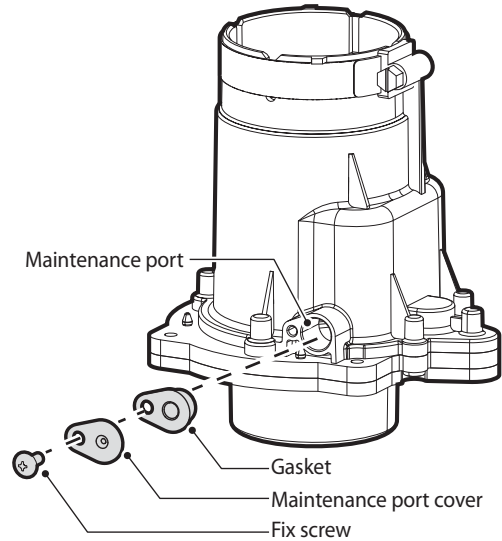
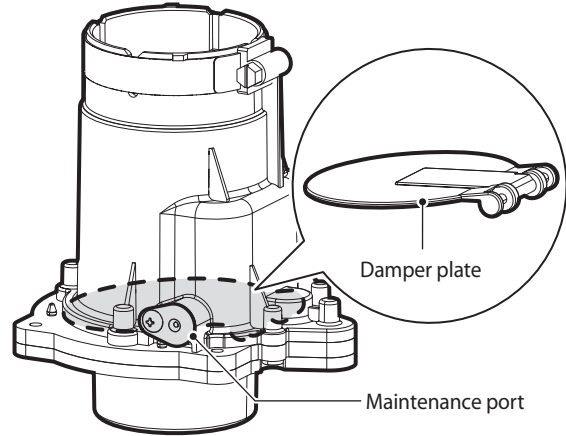

Refer to < Maintenance > for detailed inspection procedures.
Navien Backflow Damper (Back-draft Damper)

Note When using a common vent in a cascade system, backflow devices are required to prevent exhaust from entering the building.

Starting the Common Vent System

Backflow Damper Assembly

Follow the instructions below to assemble the backflow damper on the NPE water heater units:

1. Remove the screws from the exhaust vent adapter.

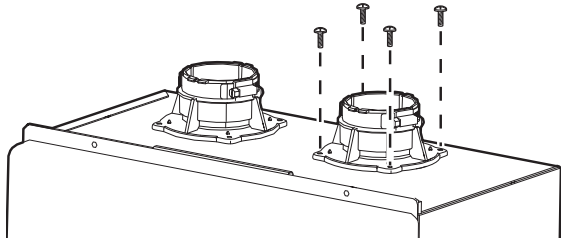

2. Detach the exhaust vent adapter.

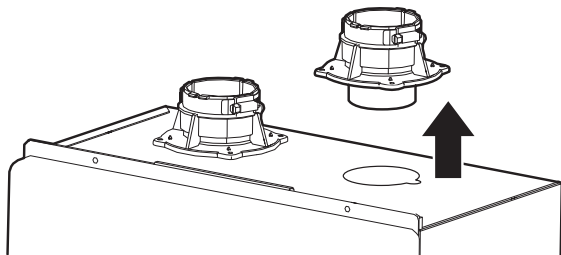

3. Connect the backflow damper to the exhaust duct of the water heater unit.

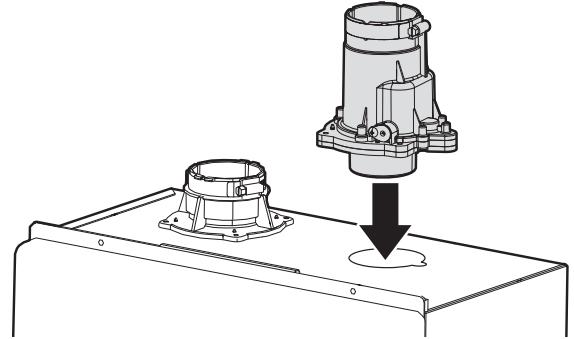

4. Tighten the four mounting screws to secure the backflow damper in place. The screws (x 4) are supplied with the backflow damper.

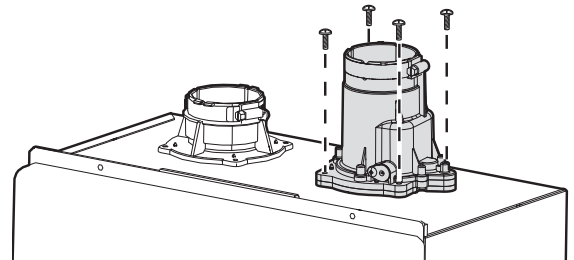

Connecting the Pipe to the Damper

1. Insert 2" vent pipe to the backflow damper to start the vent run.

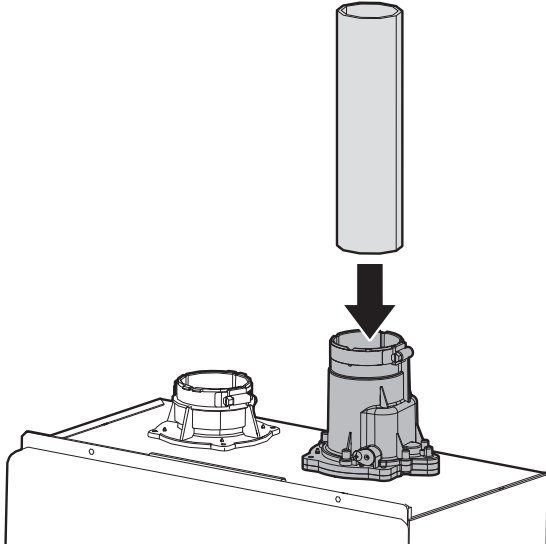

2. Completely slide the vent pipe ends into the transition fitting. Tighten the clamp with a screwdriver to properly seal the joint.

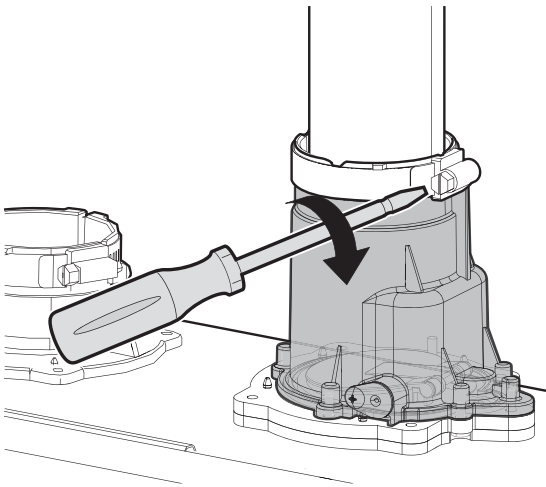

Assembling the T Joint

1. Connect an 8"-to-2" reducer to the 8" tee. Apply solvent cement to the mating surfaces.

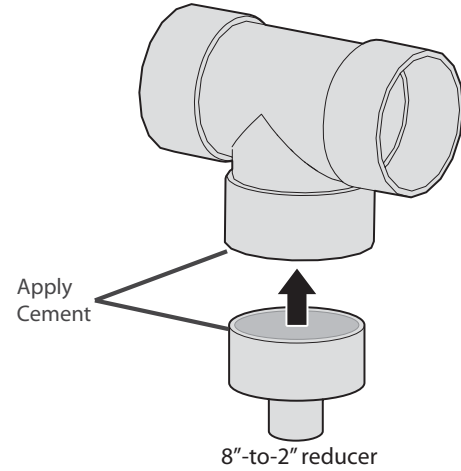

Note

Multiple reducers can be used to allow proper connection of 2" vent pipe to the common vent system.

2. Assemble the tee joint assembly (8"-to-2" reducer + tee joint) to the vent pipe. Apply solvent cement to the mating surfaces.

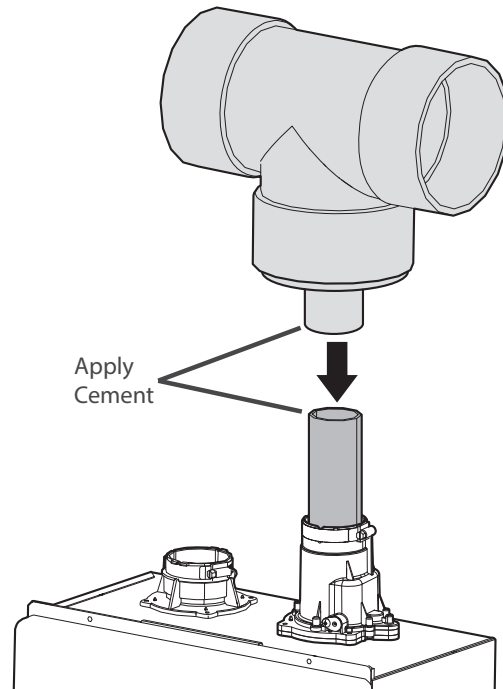

Connecting and Terminating the Vent Pipe

Refer to the following example to install the common vent system. The installation area should be measured to ensure that sufficient space is available to install the water heater units and the common vent system. Ensure that the common vent system is installed near the water heater units while satisfying all clearance requirements that are specified in this manual as well as the Installation Manuals supplied with the water heater units.

Connecting the Main Pipe Runs to T Joint

After connecting the tee joint to the 8"-to-2" reducer, connect the main trunk pipe to each side of the tee. Each trunk pipe is connected to the other tee joint. Refer to <"Connecting Pipes with Cement"> on page 44 for more information.

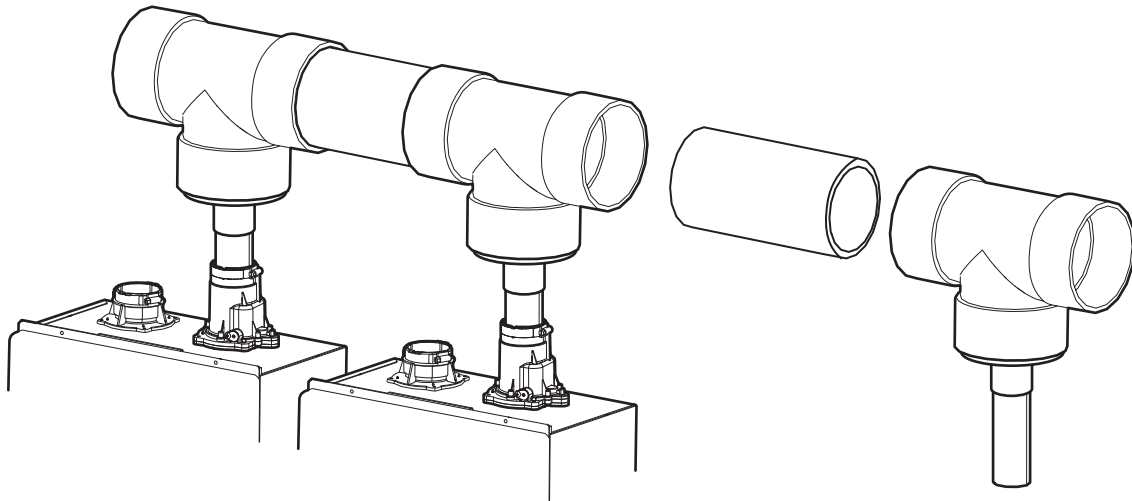

Installing the System Termination

End caps, pipe elbows or tee joints can be used at the open ends of the intake and exhaust vent pipes. Refer to the following installation examples that depict how the parts are fitted at the end of the common vent system piping.

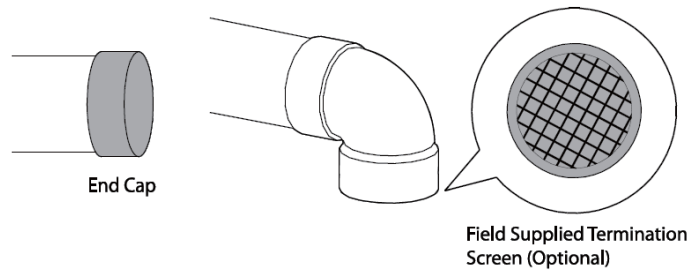

Note

The illustration is intended for reference purposes only.

Setting Up the Common Vent System

DANGER

Incorrect DIP switch settings may lead to severe personal injury, death, or property damage.

Refer to the following figures when setting DIP switches.

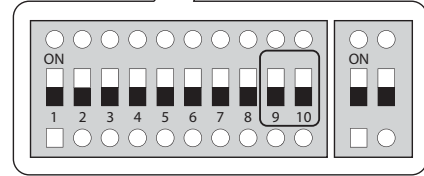
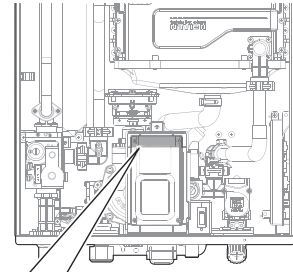
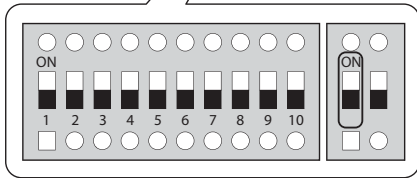
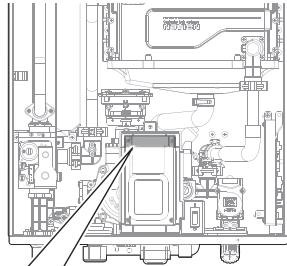

Switch (10-Switch DIP)	Function	Setting	
9 & 10	High Altitude Settings	0 – 1,999 ft (0 – 609 m)	9-OFF, 10-OFF
		2,000 – 4,500 ft (610 – 1,372 m)	9-ON, 10-OFF

Switch (2-Switch DIP)	Function	Setting	
1	Cascade Vent Settings	Common Vent	1-OFF
		Individual Vent	1-ON

Note

The NPE series water heaters may be installed at elevations up to 4,500 ft (1,372 m) for use with Natural Gas and Propane. To use the water heaters in the common vent system at a specific altitude, the DIP switches should be set as described above.

Common Vent Termination Clearances

Direct Vent Application – Vertical Installation

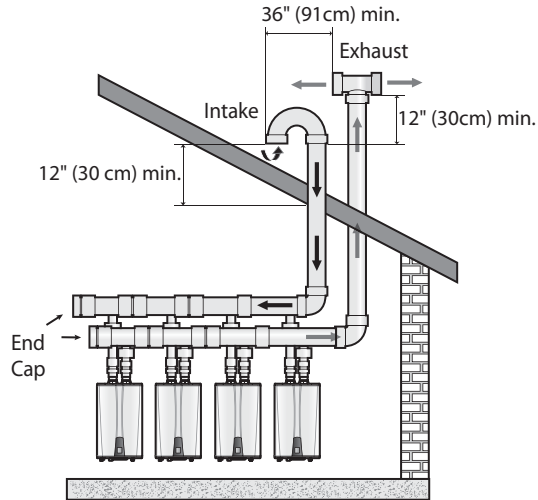

Venting Intake and Exhaust to Different Locations

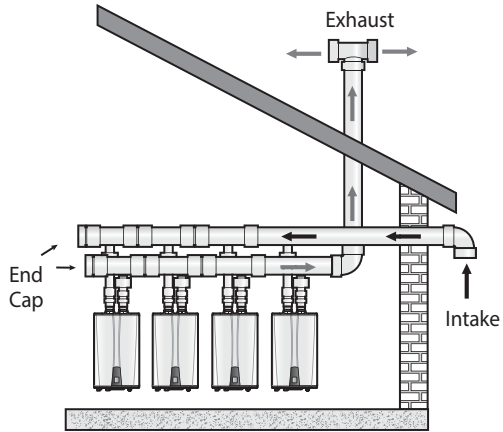

Direct Vent Application – Horizontal Installation

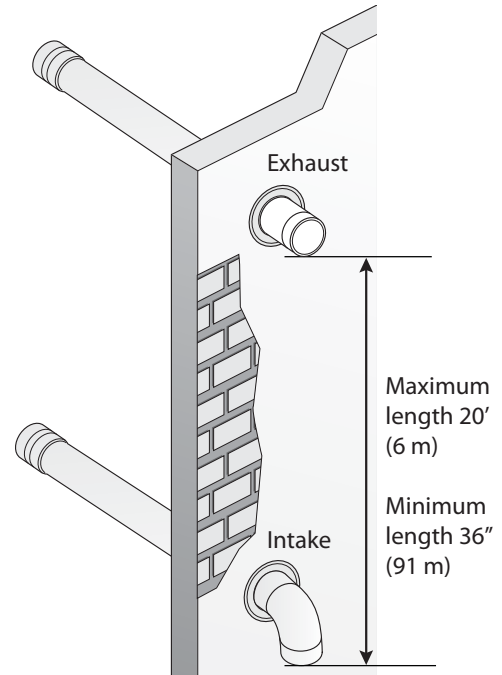

Note

- The illustration is intended for reference purposes only.
- Direct the exhaust away from any building openings.
- During cold weather situations, the temperature of the exhaust will be much warmer than the ambient air. Therefore, you will see water vapor being produced at the termination.

Exhaust Vent Termination Clearances (For Direct Vent)

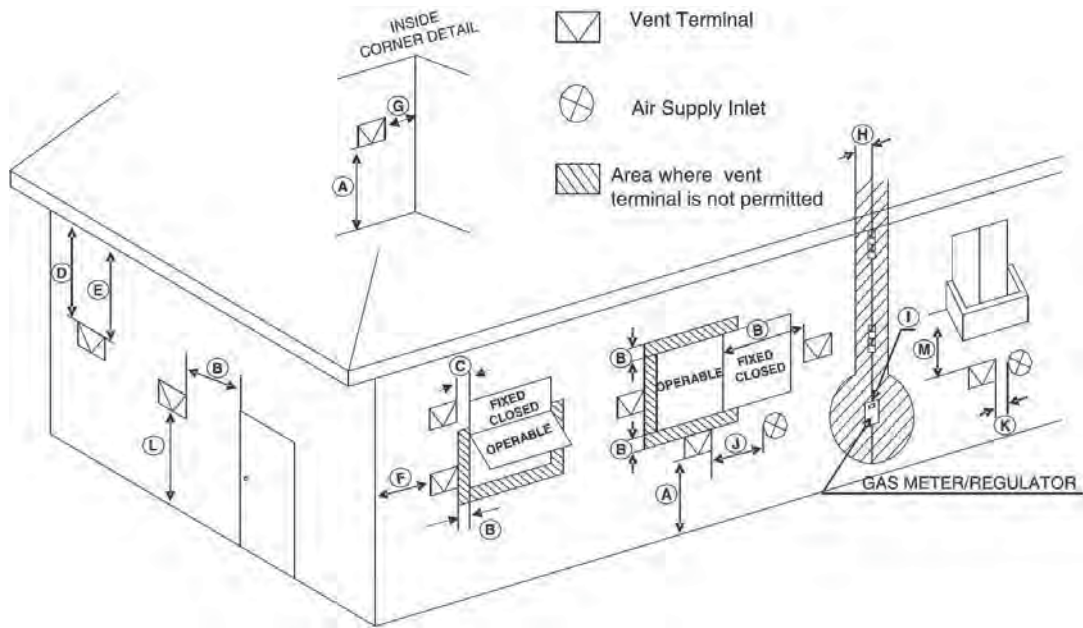

Ref	Description	Canadian Direct Vent Installations ¹	U.S. Direct Vent Installations ²
A	Clearance above grade, veranda, porch, deck, or balcony	12 in (30 cm)	12 in (30 cm)
B	Clearance to window or door that may be opened	12 in (30 cm)	12 in (30 cm)
C	Clearance to permanently closed window	*	*
D	Vertical clearance to ventilated soffit located above the terminal within a horizontal distance of 2 feet (61 cm) from the center line of the terminal	*	*
E	Clearance to unventilated soffit	*	*
F	Clearance to outside corner	*	*
G	Clearance to inside corner	*	*
H	Clearance to each side of center line extended above meter/regulator assembly	3 ft (91 cm) within a height 15 ft above the meter/regulator assembly	*
I	Clearance to service regulator vent outlet	3 ft (91 cm)	*
J	Clearance to nonmechanical air supply inlet to building or the combustion air inlet to any other appliance	36 in (91 cm)	12 in (30 cm)
K	Clearance to a mechanical air supply inlet	6 ft (1.83 m)	3 ft (91 cm) above if within 10 ft (3 m) horizontally
L	Clearance above paved sidewalk or paved driveway located on public property	7 ft (2.13 m)†	*
M	Clearance under veranda, porch deck, or balcony	12 in (30 cm)‡	*

¹ In accordance with the current CSA B149.1 Natural Gas and Propane Installation Code

² In accordance with the current ANSI Z223.1 / NFPA 54 National Fuel Gas Code

† A vent shall not terminate directly above a sidewalk or a paved driveway that is located between two single family dwellings, that serves both dwellings.

‡ Permitted only if the veranda, porch, deck, or balcony is fully open on a minimum of two sides beneath the floor.

* Clearance in accordance with local installation codes and the requirements of the gas supplier.

Maintenance

Periodically check the damper condition inside the backflow damper through the maintenance port to ensure optimal performance of the system. Follow the instructions to check the damper condition and replace the backflow damper if necessary.

3. Remove the screw that fixes the maintenance port cover to the backflow damper, and then remove the gasket and the maintenance port cover.

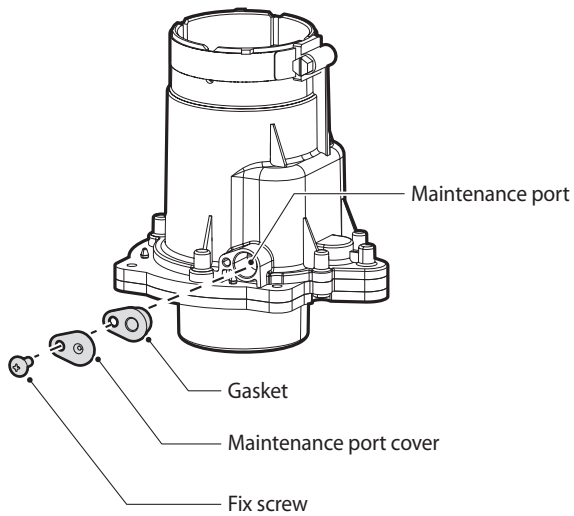

4. Through the maintenance port, check the operating condition of the damper plate inside the backflow damper.

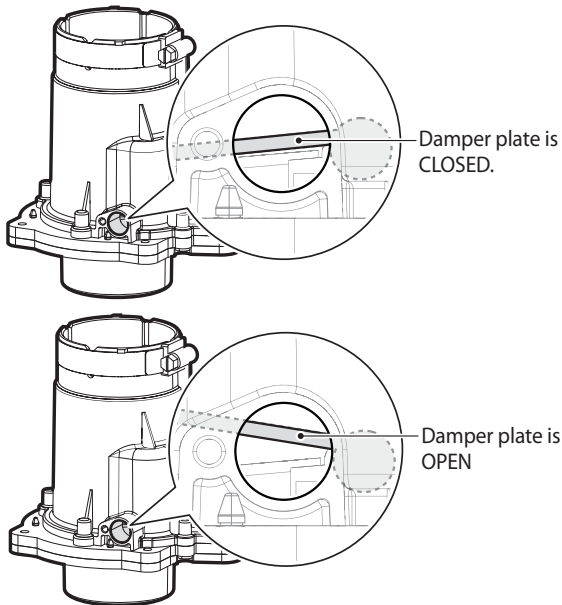

5. Reinstall the gasket and maintenance port cover, and then fix them with a set screw.

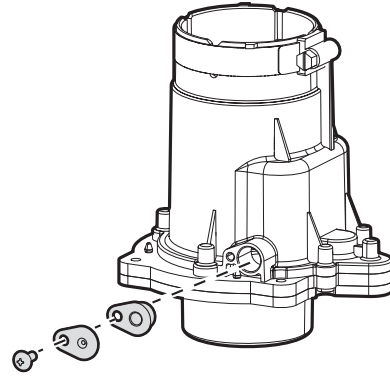

6. Visually inspect the maintenance port to ensure that the gasket is properly installed between the maintenance port and the maintenance port cover.

WARNING

Ensure that the gasket is properly installed under the maintenance port cover, after checking the operating condition of the damper through the maintenance port. Harmful exhaust gas may leak if the gasket is not installed, or if it is not installed properly.

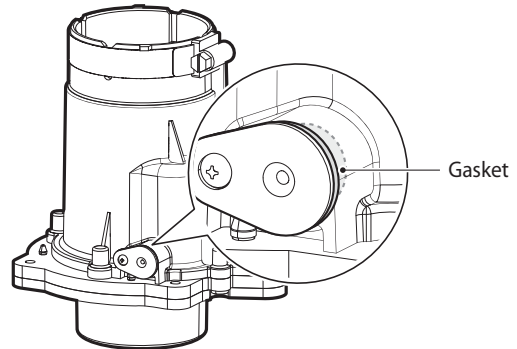

6. Appendixes

6.1 Gas Conversion

This water heater is configured for Natural Gas from the factory. If conversion to Propane Gas is required, the conversion kit supplied with the water heater must be used.

WARNING

This conversion kit shall be installed by a qualified service agency* in accordance with Navien's instructions and all applicable codes and requirements of the authority having jurisdiction. The information in these instructions must be followed to minimize the risk of fire or explosion or to prevent property damage, personal injury or death. The qualified service agency is responsible for the proper installation of this kit. The installation is not proper and complete until the operation of the converted appliance is checked as specified in the manufacturer's instructions supplied with the kit.

* A qualified service agency is any individual, firm, corporation or company which either in person or through a representative is engaged in and is responsible for the connection, utilization, repair or servicing of gas utilization equipment or accessories; who is experienced in such work, familiar with all precautions required, and has complied with all of the requirements of the authority having jurisdiction.

In Canada: The conversion shall be carried out in accordance with the requirements of the provincial authorities having jurisdiction and in accordance with the requirements of the CAN-B149.1 and CAN1-B149.2 Installation Code.

Tools Required:

- Phillips Screwdriver
- Flathead Screwdriver
- $\frac{5}{32}$ in or 4 mm Allen Wrench
- Combustion Analyzer or Dual Port Manometer
- Gas Leak Detector

Included Items:

- Gas Orifice (refer to below table)

Water Heater	NG	LP
NPE-150S	Ø6.30	Ø5.10

Water Heater	NG		LP	
	1STAGE	2STAGE	1STAGE	2STAGE
NPE-180A NPE-180S	Ø4.80	Ø5.95	Ø3.80	Ø4.70
NPE-210A NPE-210S	Ø6.10	Ø6.30	Ø4.50	Ø4.80

Water Heater	NG		LP	
	1STAGE	2STAGE	1STAGE	2STAGE
NPE-240A NPE-240S	Ø6.10	Ø6.30	Ø4.50	Ø4.80

Table 1. Orifice size

- Gas Pressure and Conversion Kit Number Labels

Procedure:

1. Turn off both gas and water supply to the water heater.
2. Using a Phillips hand screwdriver, remove 4 screws (2 from the top and 2 from the bottom) of the front cover assembly to gain access to the internal components. See Figure 1 for illustration of the front cover on the unit.



Figure 1. NPE Series Front cover

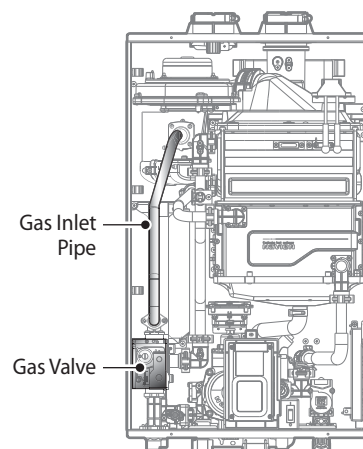

Figure 2. NPE Series Internal Components

3. Once the front cover is removed, place it in a safe location to prevent accidental damage. With the internal components exposed, locate the gas inlet pipe and the Gas Valve near the left side of the unit which are highlighted in Figure 2.
4. Use a Phillips screwdriver to remove the two screws at Location A - the connection below the Gas Valve where it connects to the pipe. See Figure 3 for reference. Once the screws are removed, carefully separate the pipe from the Gas Valve.
5. Once the gas inlet pipe is detached from the Gas Valve, find Location B - the connection above the Gas Valve where it is attached to the Fan Motor Assembly. Carefully remove the four screws by hand using a Phillips screwdriver and pull the Gas Valve away from the Fan Assembly to access the Gas Orifice.

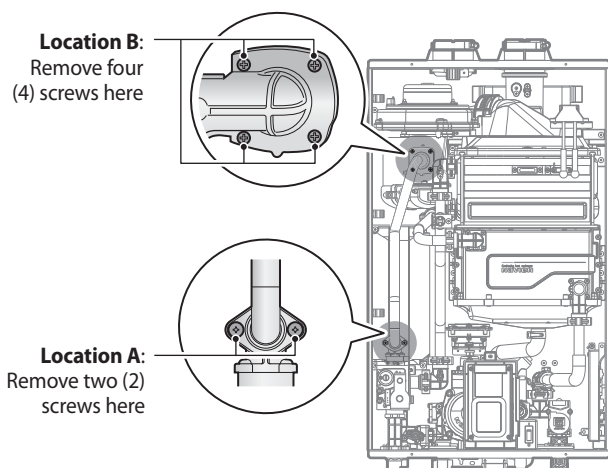

Figure 3. Detaching Gas Valve from Gas Inlet Pipe and Fan Motor Assembly

6. Once the Gas Orifice is exposed, remove the two screws that hold the part in place. Remove the Gas Orifice from its housing and prepare the new Gas Orifice for the LP conversion for installation.

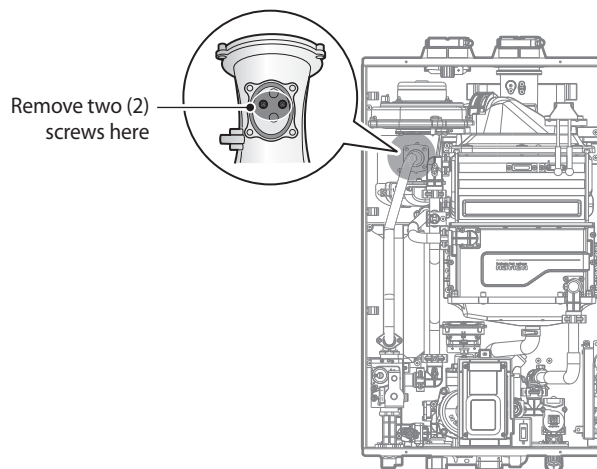
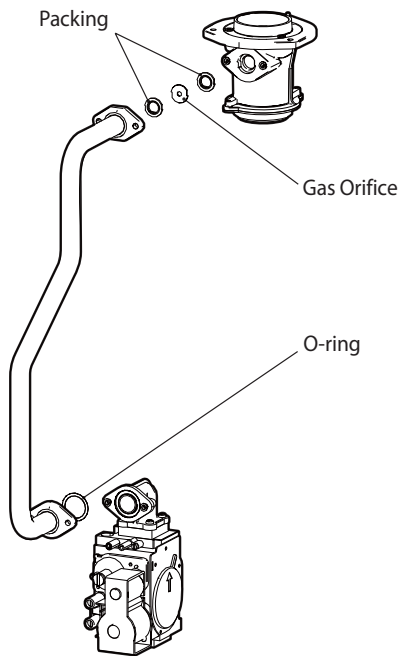

Figure 4. Access to Gas Orifice in Fan Assembly

! WARNING

- DO NOT adjust or attempt to measure gas valve outlet pressure. The gas valve is factory-set for the correct outlet pressure. This setting is suitable for natural gas and propane, requiring no field adjustment.
- Attempting to alter or measure the gas valve outlet pressure could result in damage to the valve, causing potential severe personal injury, death or substantial property damage. Navien water heaters are shipped ready to fire natural gas ONLY.



<NPE-150S>

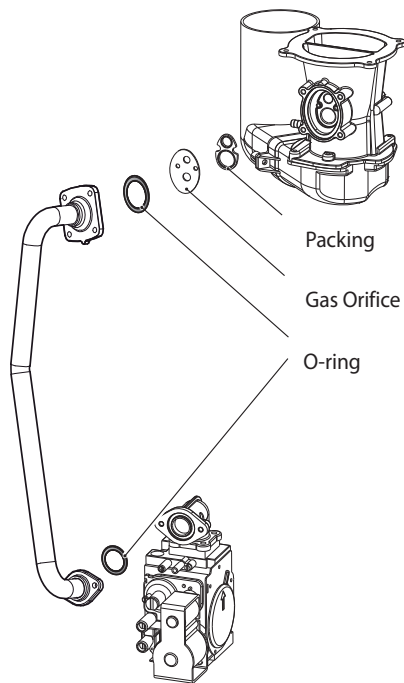

<NPE-180A/ 210A/ 240A/ 180S/ 210S/ 240S>

Figure 5. Exploded view of Gas assembly

! DANGER

See Figure 5. Inspect the O-ring between the gas valve and gas valve inlet adapter whenever they are disassembled. The O-ring must be in good condition and must be installed. Failure to comply will cause a gas leak, resulting in severe personal injury or death.

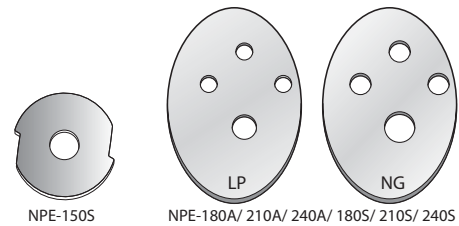
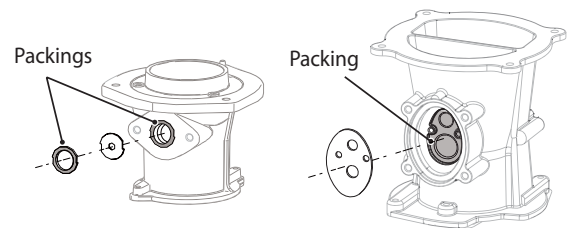

Figure 6. Orifice identification

- Remove the Gas Orifice, ensure that the packing is properly seated inside the port, and then install the new Gas Orifice for use with LP gas. Ensure that the Orifice is properly seated on the packing inside the port before proceeding to the next step.



- Replace the gas inlet pipe to its original position and use all screws to secure all connections.

Note Do not overtighten as this may damage or crack the components.

- Set the Front Panel Dip switch according to the gas type.

! WARNING

Be sure to turn off the power before changing the DIP switch setting.

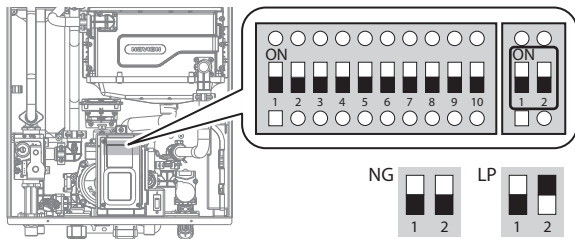

! DANGER

- When conversion is required, be sure to set the Front Panel DIP switches according to the supply gas type.
- Failure to properly set the DIP switches could cause carbon monoxide poisoning, resulting in severe personal injury or death.

10. Turn on the gas and water supply to the water heater.

11. Measure and adjust the gas/air ratio.

Option 1. Using Combustion Analyzer (recommended)

- Loosen the screw, rotate the plate and remove the gasket to access the emissions monitoring port as shown in Figure 7.
- Insert the analyzer into the port (Figure 7).

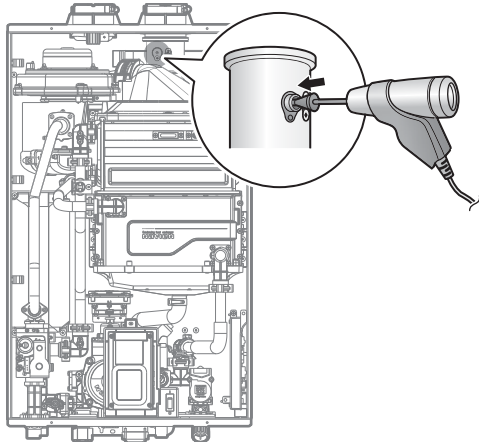

Figure 7

Water Heater	Fuel	High fire	Low fire
		%CO ₂	%CO ₂
NPE-150S	NG	8.9	9.5
	LP	10.2	10.8
NPE-180A NPE-180S	NG	8.9	9.5
	LP	10.2	10.8
NPE-210A NPE-210S	NG	8.9	9.5
	LP	10.2	10.8
NPE-240A NPE-240S	NG	8.9	9.5
	LP	10.2	10.8

Table 2. CO₂ and CO value
(CO₂ values must be within 0.5% of the values listed.)

- Fully open several hot water fixtures and set the water heater to operate at 1-stage MIN mode (refer to page 59). Measure the CO₂ value at low fire. If the CO₂ value is not within 0.5% of the value listed in Table 2, the gas valve set screw will need to be adjusted. If adjustment is necessary, locate the set screw as shown in Figure 8. Using a $\frac{5}{32}$ in or 4 mm Allen wrench, turn the set screw no more than $\frac{1}{4}$ turn clockwise to raise or counterclockwise to lower the CO₂ value.

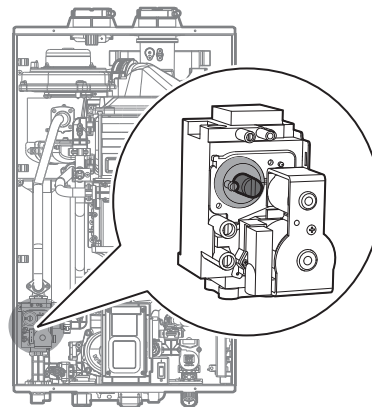

Figure 8. Set Screw Location

Note

The set screw is located behind the screw-on cover. This must be removed first.

- d. Fully open several hot water fixtures and set the water heater to operate at 2-stage MAX mode (refer to page 59). Measure the CO₂ value at high fire. If the CO₂ values do not match Table 2 at high fire, do not adjust the gas valve. Check for the proper Gas Orifice.

! DANGER

Improper gas valve settings can cause severe personal injury, death or substantial property damage.

Option 2. Using Digital Manometer

- a. Open the offset pressure port by loosening the screw two turns as shown in Figure 9.

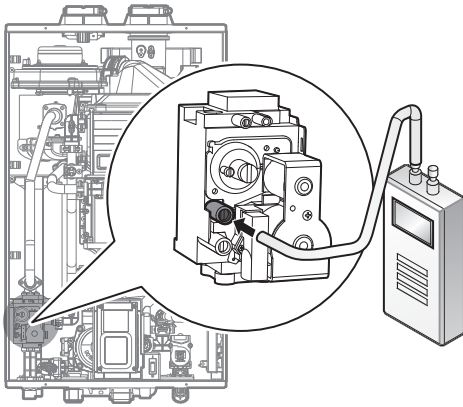

Figure 9

- b. Connect a manometer to the offset pressure port. For dual port manometers, use the positive pressure side.

Model	Kit Part No.	Gas Type	Offset
NPE-150S	NAC-N6	LP	-0.03 in ± 0.01 in
	NAC-L6	NG	-0.04 in ± 0.01 in
NPE-180A NPE-180S	NAC-01	LP	-0.03 in ± 0.01 in
	NAC-100	NG	-0.04 in ± 0.01 in
NPE-210A NPE-210S	NAC-02	LP	-0.02 in ± 0.01 in
	NAC-200	NG	-0.04 in ± 0.01 in
NPE-240A NPE-240S	NAC-03	LP	-0.02 in ± 0.01 in
	NAC-300	NG	-0.04 in ± 0.01 in

Table 3. Offset value for low fire

- c. Fully open a hot water fixture and set the water heater to operate at 1-stage MIN mode (refer to page 59). Measure the offset value at low fire and compare it to the values in Table 3. If the offset value is out of range, the gas valve set screw will need to be adjusted. If adjustment is necessary, locate the set screw as shown in Figure 10. Using a 5/32 in or 4 mm Allen wrench, turn the set screw no more than 1/4 turn clockwise to raise or counterclockwise to lower the offset value.

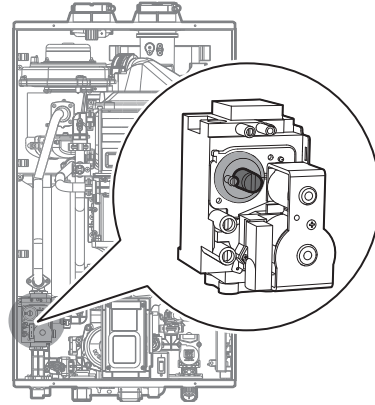

Figure 10

Note

The set screw is located behind the screw-on cover. This must be removed first.

- d. At high fire, do not check the offset value and never adjust the gas valve.

! DANGER

Improper gas valve settings can cause severe personal injury, death or substantial property damage.

12. Once the CO₂ or offset values have been confirmed, apply the included conversion stickers to show that the appliance has been converted to propane gas. Place this labels adjacent to the rating plate as shown in Figure 11.

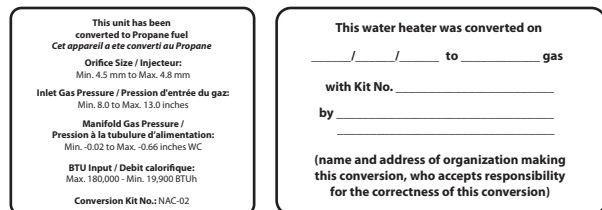

Figure 11. Proper Placement of Gas Conversion Labels

6.1.1 Setting the Operation Mode

1. Using the Front Panel, press and hold the Diagnostics Button for over 5 seconds until "1.TST" is displayed.
2. Press the + (Up) button once to change the display to "2.OPR".
3. Press the Information Button once to access the Operation Mode menu.
4. Press the + (Up) button once to set the water heater to operate at 1-stage MIN ("MIN.1").
5. To set the water heater to operate at 2-stage MAX (1-stage MAX for NPE-150S), press the + (Up) button 3 times or until "MAX.2 (MAX.1 for NPE-150S)" is displayed.
6. To exit the Operation Mode and return the water heater to normal operation, press the Reset button twice.



6.2 Technical Data

Pressure Drop Curve

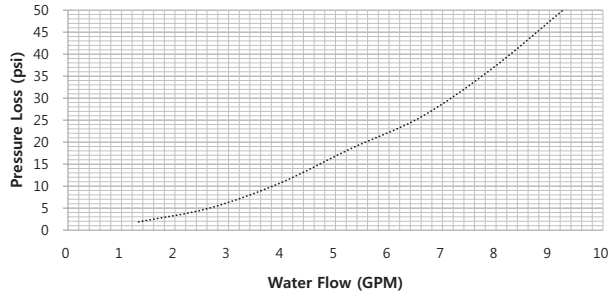

[NPE-240A/ 240S]

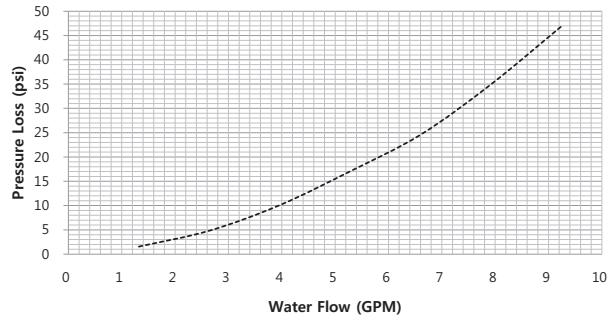

[NPE-210A/ 210S]

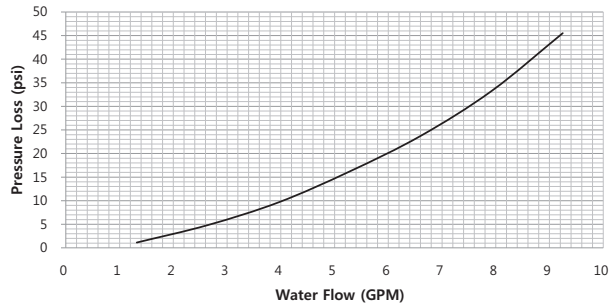

[NPE-180A/ 180S]

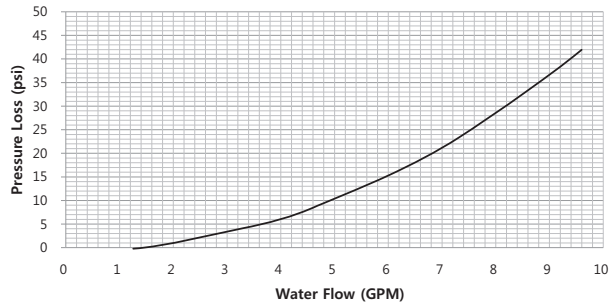

[NPE-150S]

Outlet Flow Data

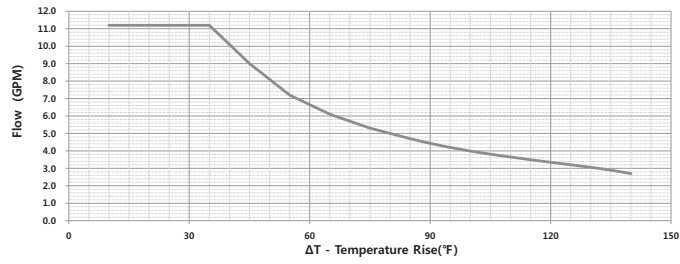

[NPE-240A]

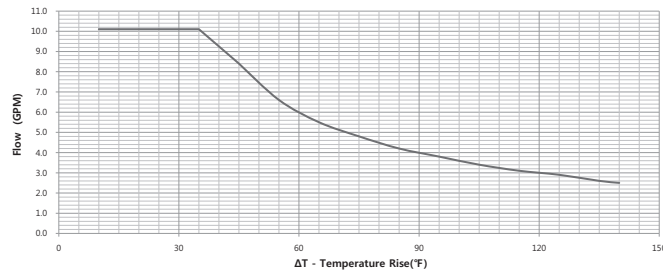

[NPE-210A]

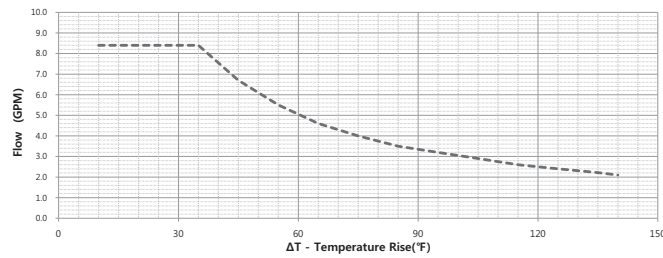

[NPE-180A]

Note

At altitudes above 2,000 ft (610m), the outlet flow will be reduced by 4% for each 1,000 ft (305 m) of altitude gain.

Outlet Flow Data

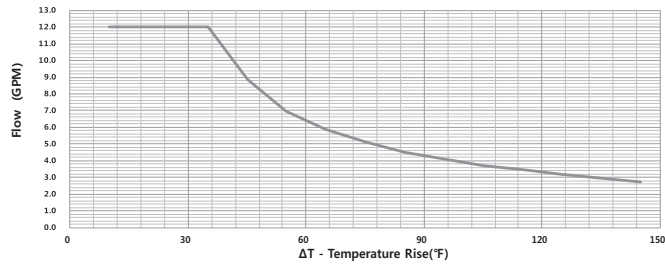

[NPE-240S]

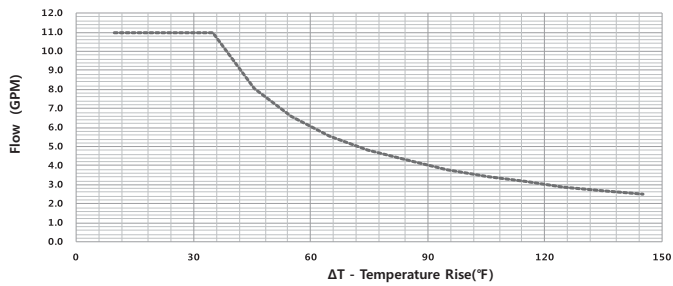

[NPE-210S]

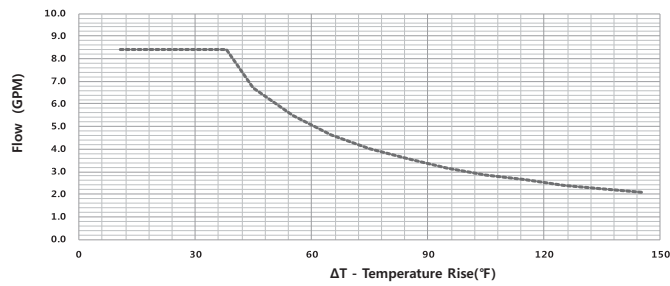

[NPE-180S]

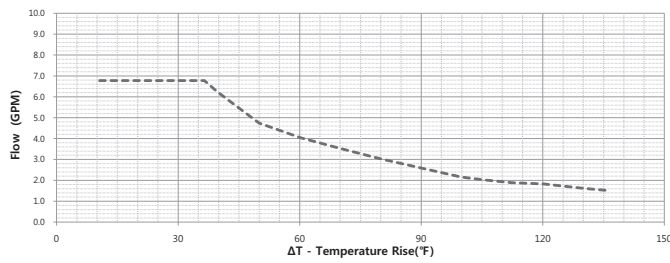

[NPE-150S]

Note

At altitudes above 2,000 ft (610m), the outlet flow will be reduced by 4% for each 1,000 ft (305 m) of altitude gain.

6.3 Wiring Diagram

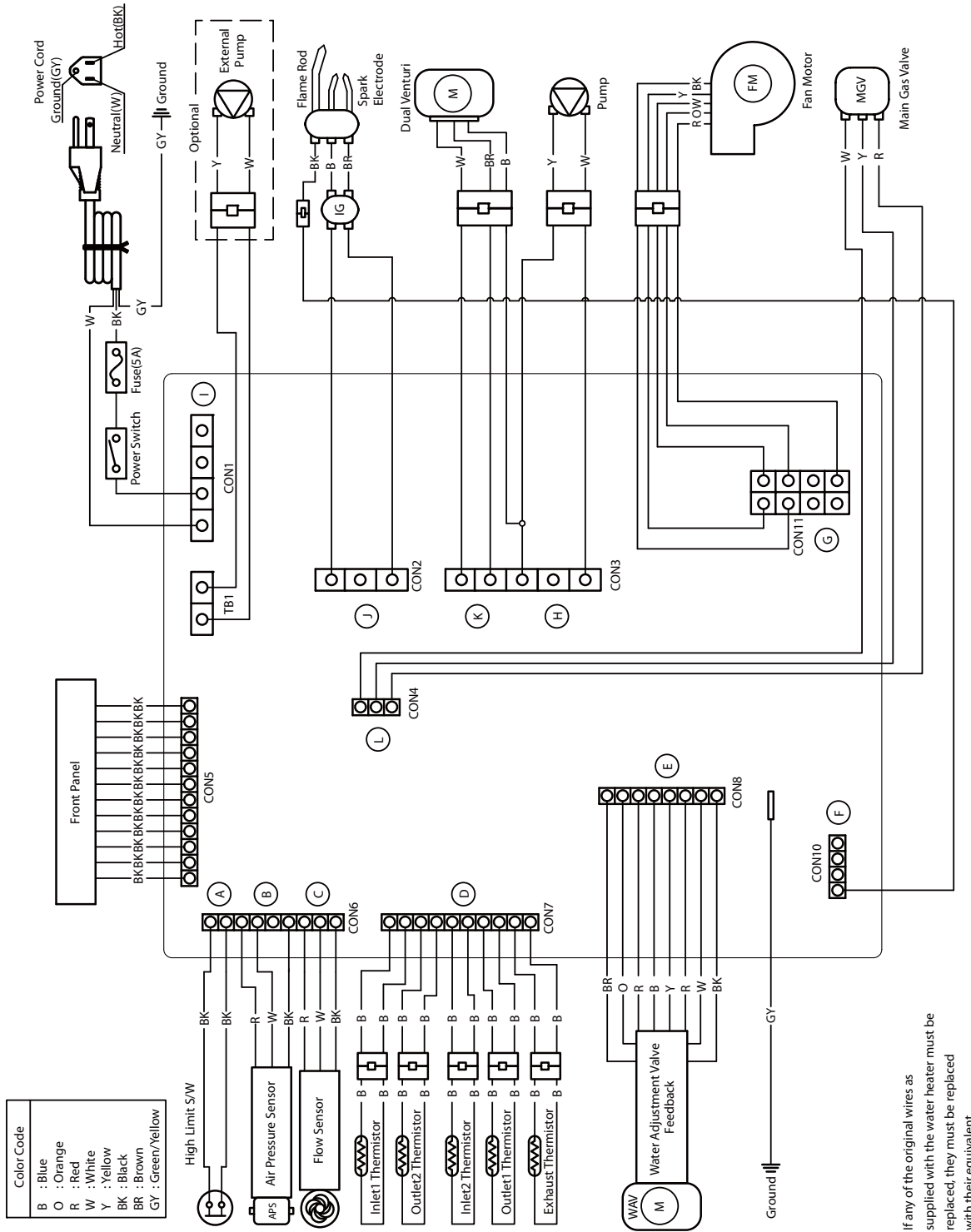

[NPE-180A/ 210A/ 240A]

If any of the original wires as supplied with the water heater must be replaced, they must be replaced with their equivalent.

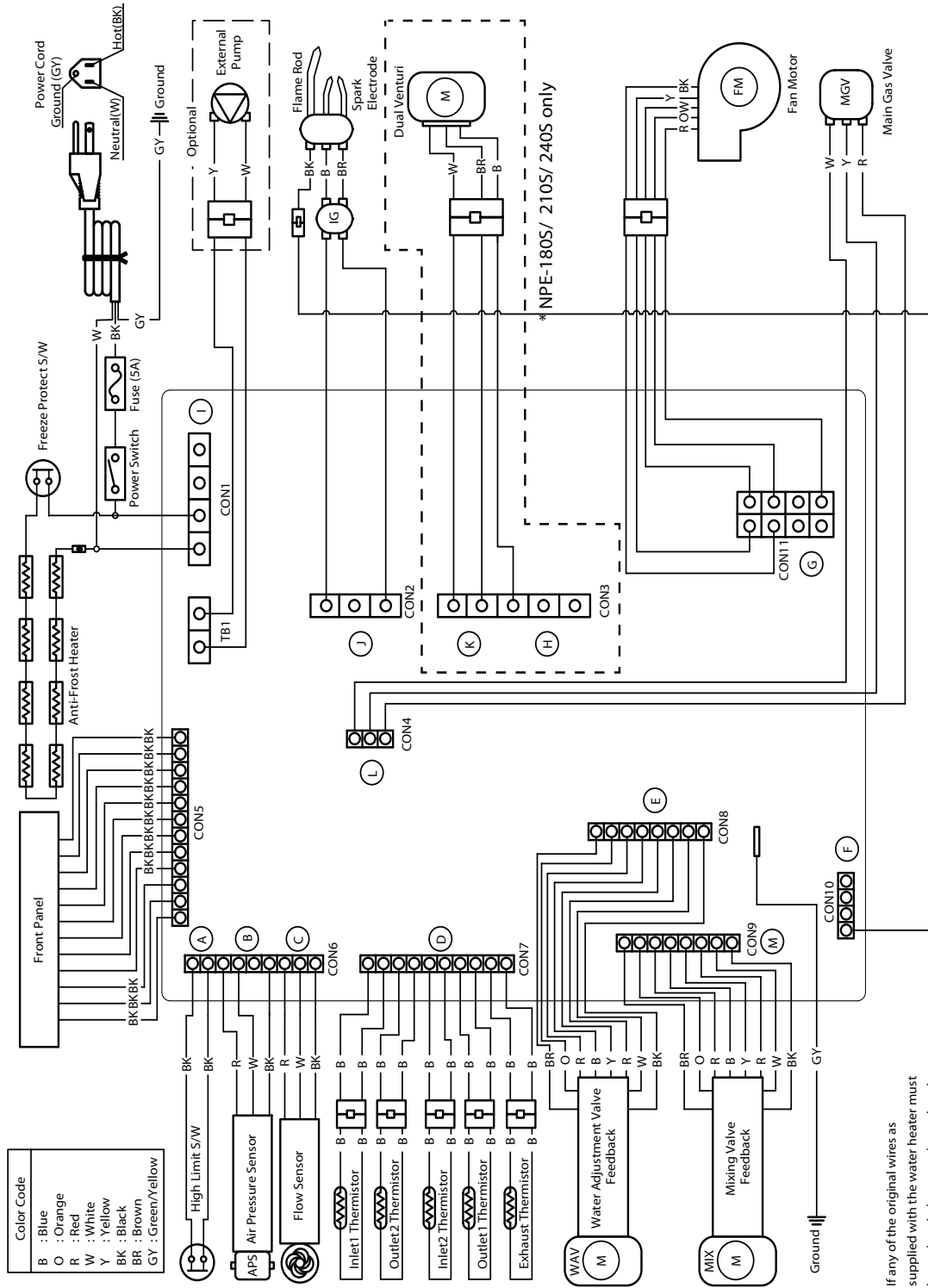

If any of the original wires as supplied with the water heater must be replaced, they must be replaced with their equivalent.

[NPE-150S/180S/ 210S/ 240S]

6.4 Ladder Diagram

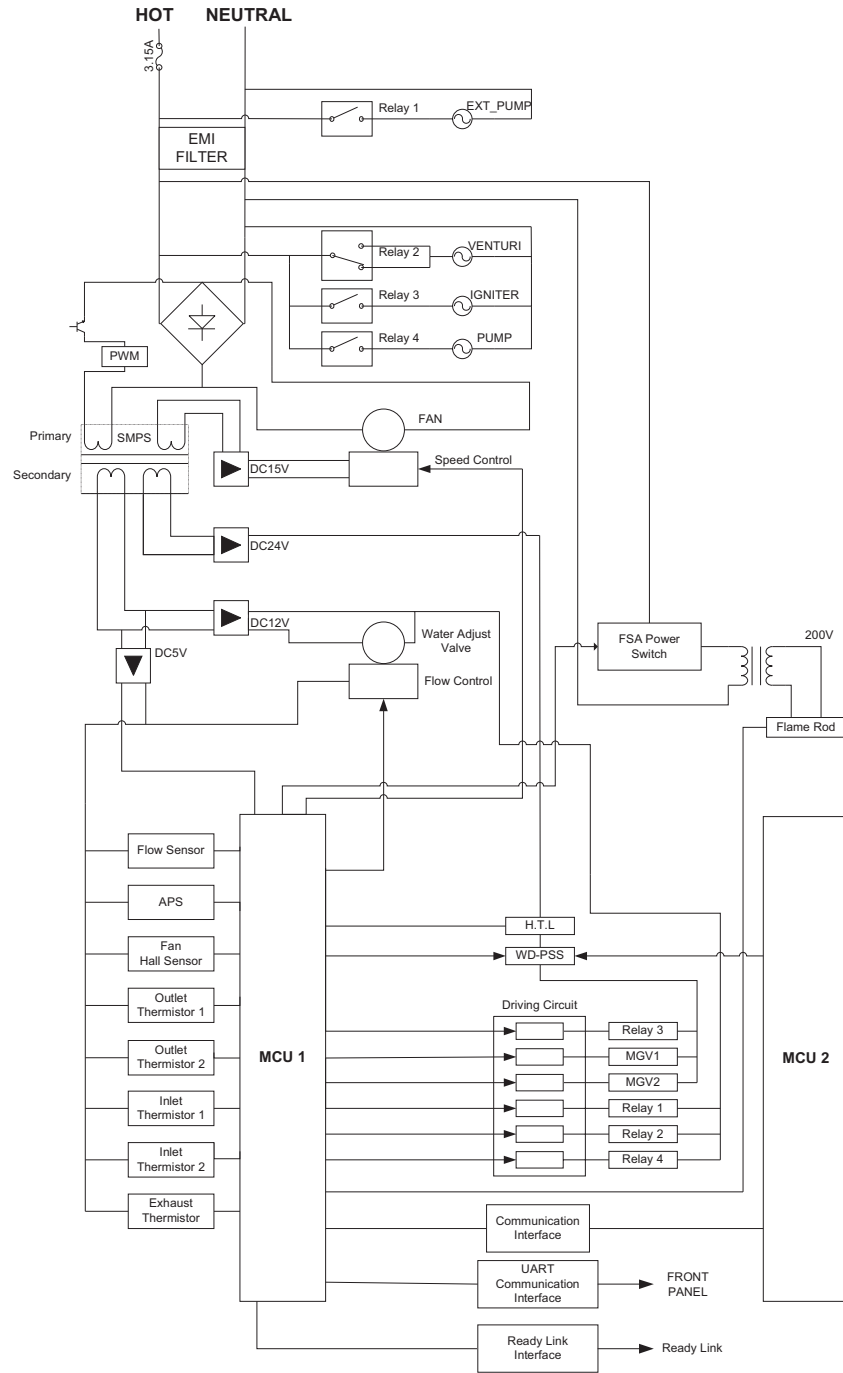

[NPE-180A/ 210A/ 240A]

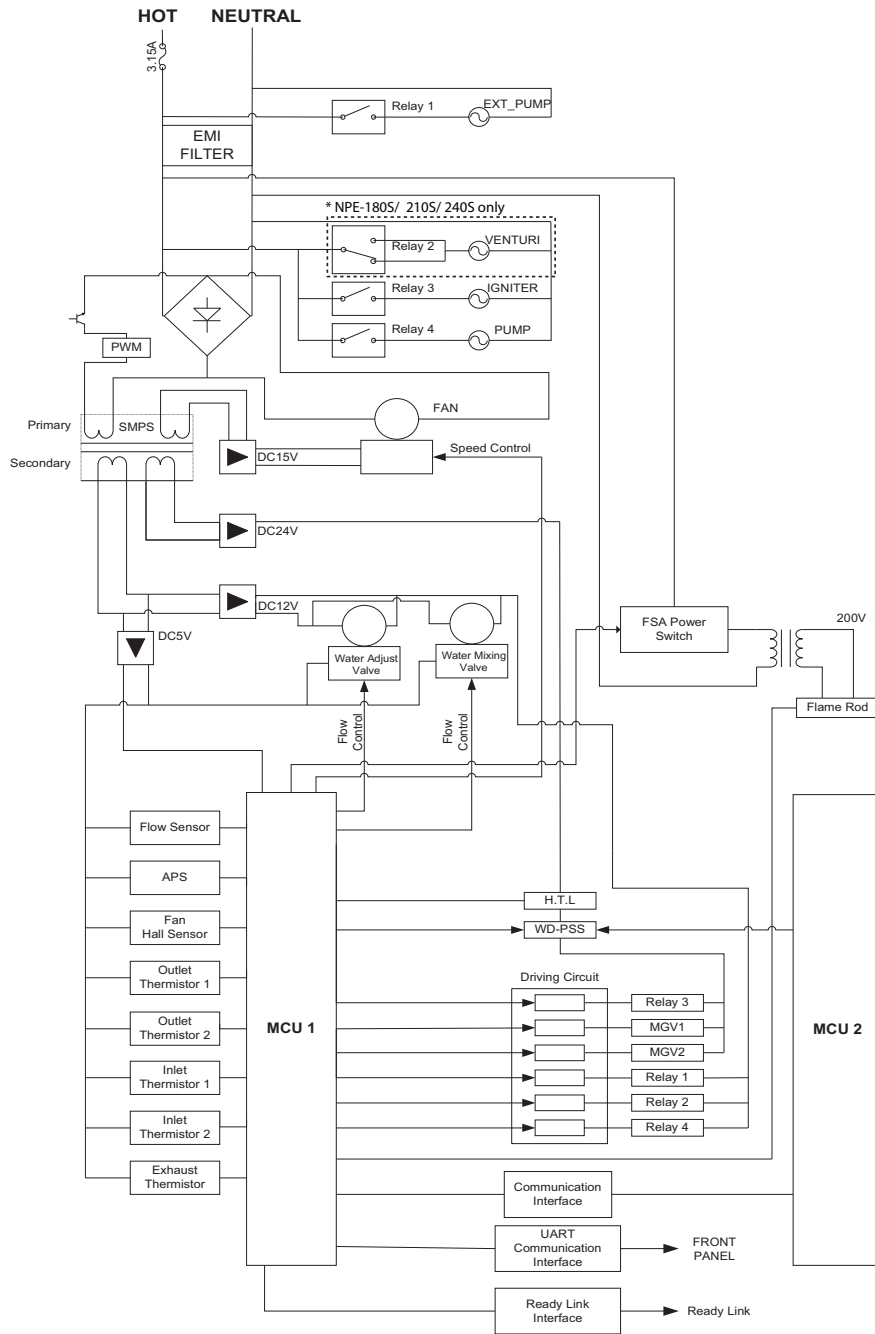

[NPE-150S/ 180S/ 210S/ 240S]

6.5 Component Assembly Diagrams and Parts Lists

6.5.1 Case Assembly

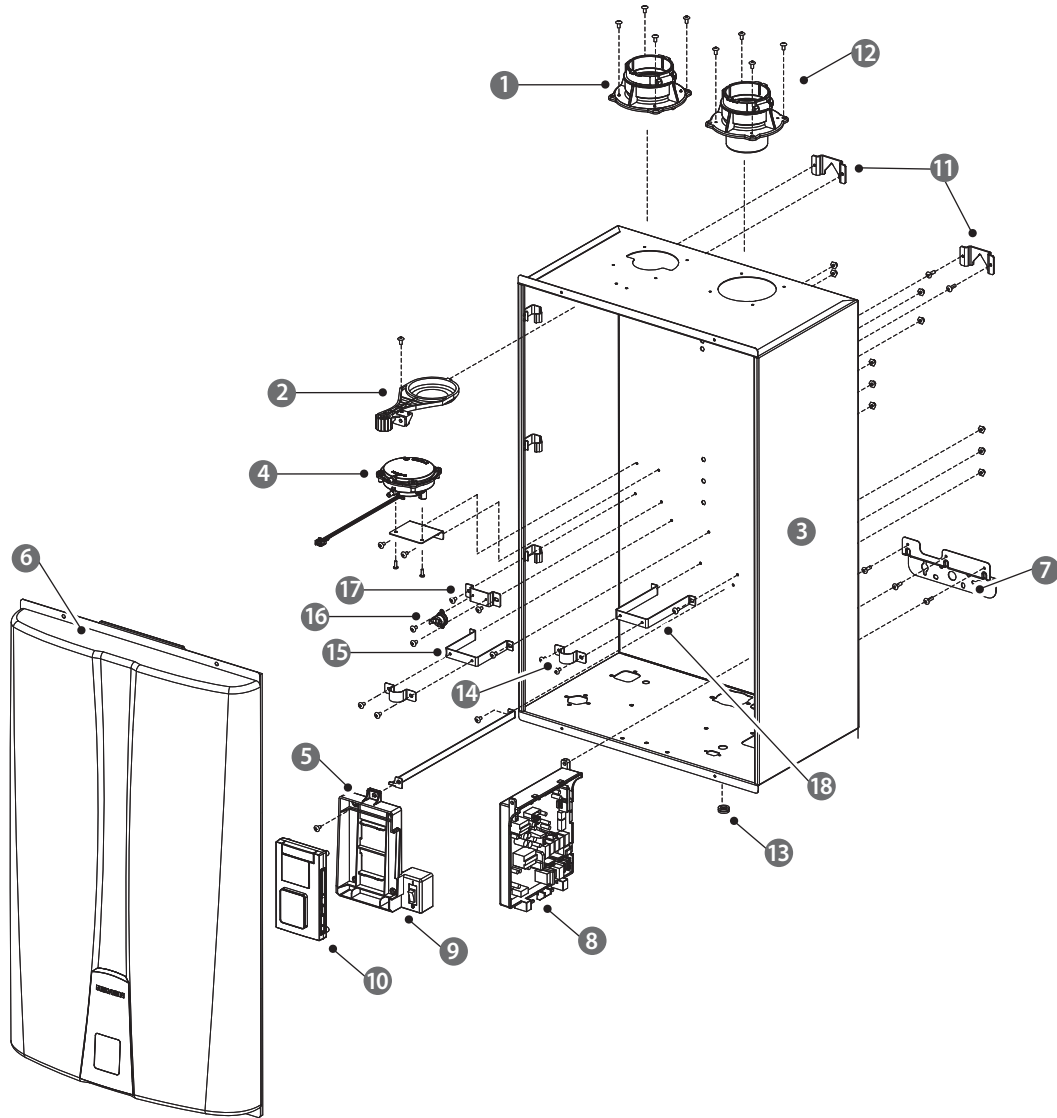

#	Description	Part #	Remark
1	Intake Air Duct Assembly	30008662B	
2	Intake Air Filter	20007667A	
3	Case	20019078C	NPE-180A/210A/240A
		20026559B	NPE-150S/180S/210S/240S
4	Air Pressure Sensor	30010346A	
5	Panel Bracket	20018388A	
6	Cover	30008678B	NPE-180A/210A/240A
		30011694A	NPE-150S/180S/210S/240S
7	Case Lower Bracket	20007643B	
8	PCB	30011969A	
9	Power Switch	30009482A	
10	Front Panel	30008333A	
11	Case Bracket	20007609A	
12	Exhaust Pipe Assembly	30008673A	
13	Rubber Ring	20025127A	
14	Saddle	20013508A	NPE-150S/180S/210S/240S
15	Saddle Bracket 1	20026170A	NPE-150S/180S/210S/240S
16	Freeze Protector Sensor	30002587A	NPE-150S/180S/210S/240S
17	Freeze Protector Sensor Bracket	20007671A	NPE-150S/180S/210S/240S
18	Saddle Bracket 2	20026172A	NPE-150S/180S/210S/240S

6.5.2 Burner Assembly(NPE-180A/ 210A/ 240A)

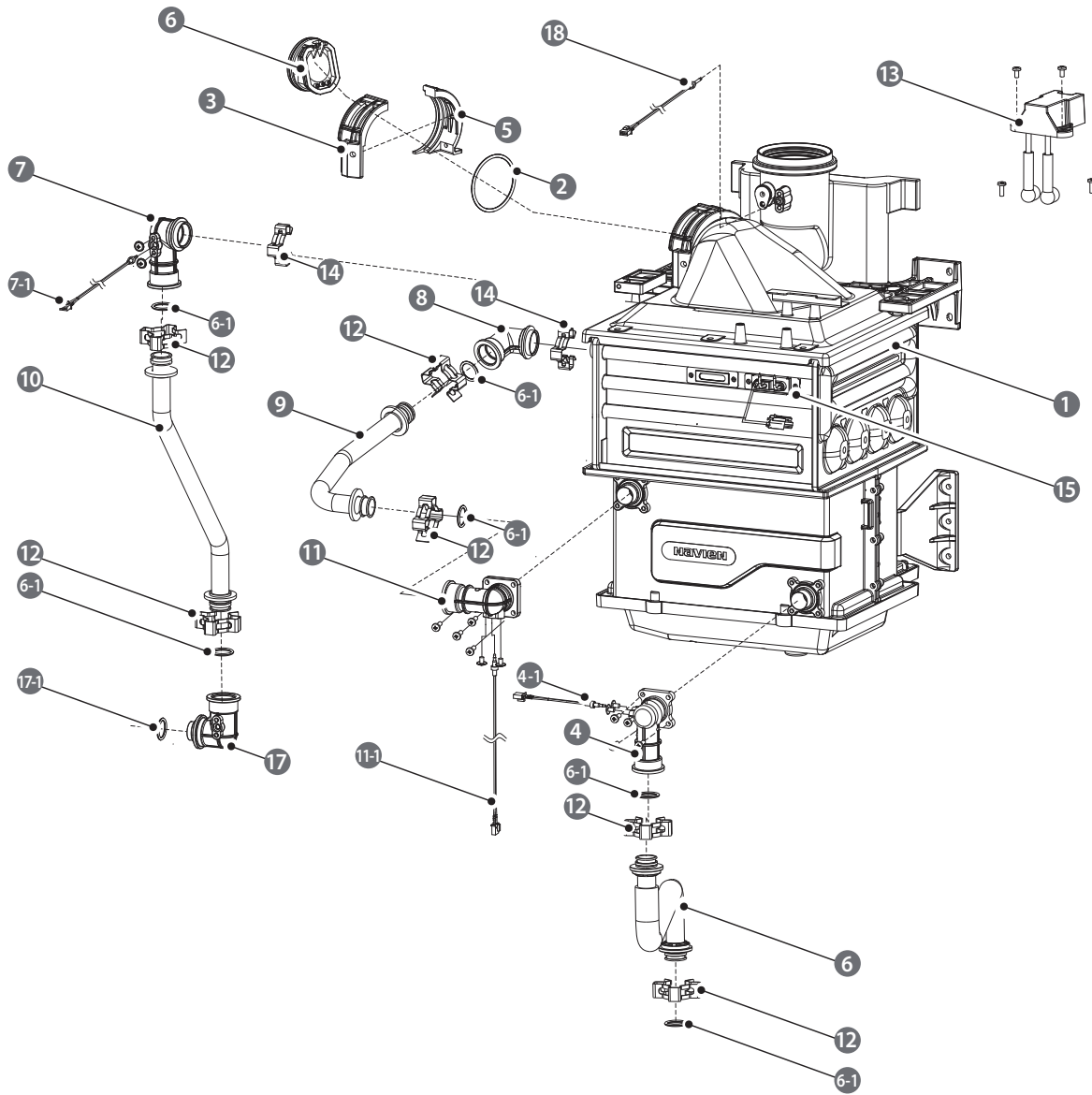

#	Description	Part #	Remark
1	Heat Exchanger Assembly	30009189A	NPE-180A
		30010812A	NPE-210A/240A
2	Fan Packing	20022744A	
3	Fan Bracket(F)	20022095A	
4	Flow Sensor Assembly	30008571A	
4-1	Thermistor	30008366A	
5	Fan Bracket(R)	20022096A	
6	Cold Inlet Pipe	30009166D	NPE-180A
		30010805D	NPE-210A/240A
6-1	O-Ring (Φ17.5x2.7t)	20006947A	
7	WPA-A (Clip)	20018344A	
7-1	Thermistor	30008366A	
8	WPA-B	20018343A	
9	H-Ex Middle Pipe	30009126A	NPE-180A
		30010803C	NPE-210A/240A
10	Hot Water Outlet Pipe	30009145A	NPE-180A
		30008442A	NPE-210A/240A
11	WPA-A (Screw)	30008569A	
11-1	Thermistor	30008366A	
12	Fastner	20017726A	
13	Ignition Transformer	30010455A	
14	Fastner	20007853A	
15	Ignitor	30008591A	
16	Damper	30008825A	
17	Buffer Tank Inlet Adapter	20018346A	
17-1	O-Ring (P16)	30009478A	
18	Thermistor	30009478A	

6.5.3 Burner Assembly(NPE-150S/180S/ 210S/ 240S)

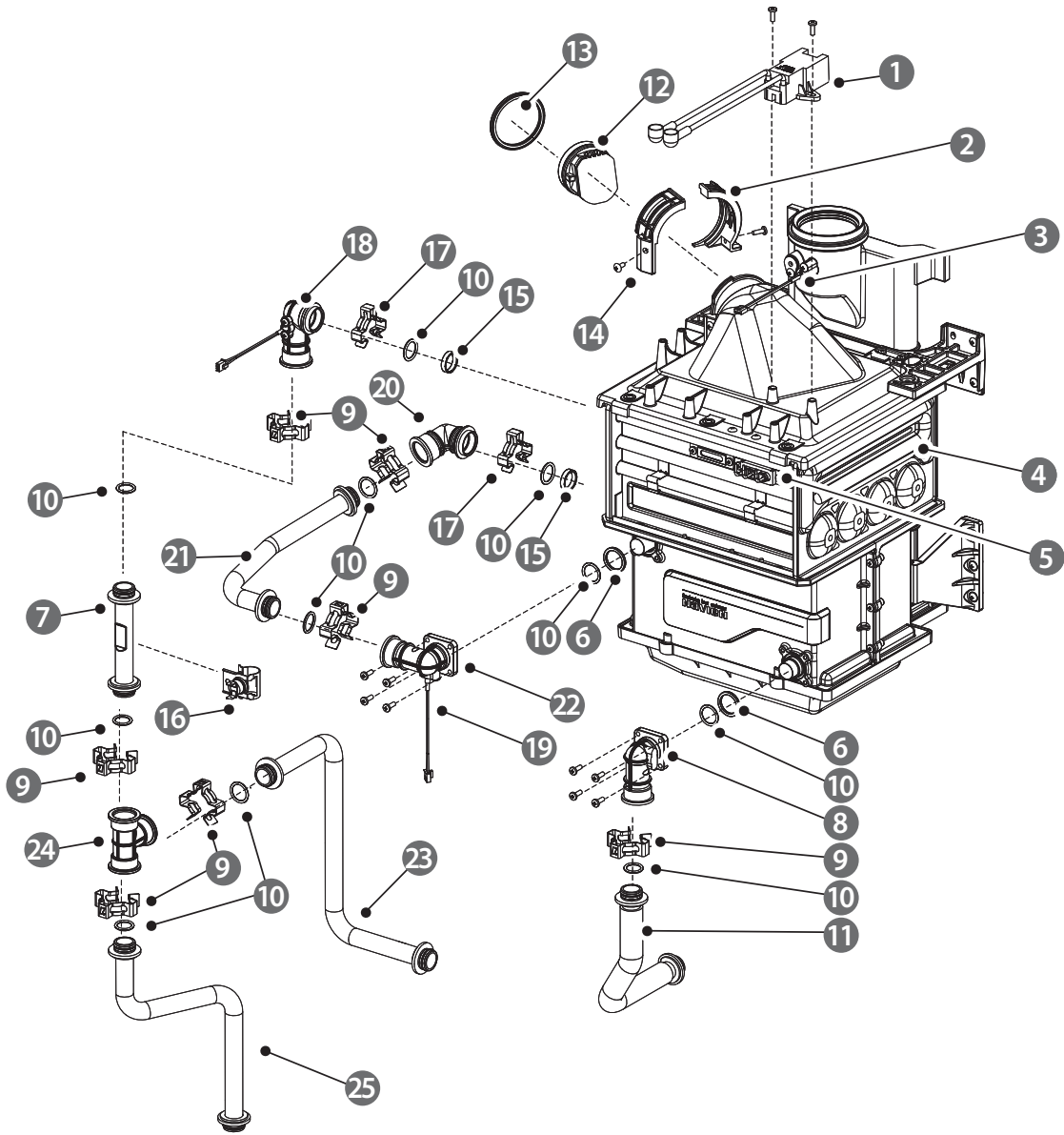

#	Description	Part #	Remark
1	Ignition Transformer	30010455A	
2	Fan Bracket (R)	20022096A	
3	Thermistor	30009478A	Exhaust
4	Heat Exchanger Assembly	30214351A	NPE-150S
		30011706A	NPE-180S
		30011705A	NPE-210S/240S
5	Ignitor	30214183A	NPE-150S
		30012226A	NPE-180S/210S/240S
6	Packing (Φ26.5x2.4t)	20006868A	
7	Heat Exchanger Outlet Pipe	30014326A	NPE-150S
		30011519A	NPE-180S
		30011515A	NPE-210S/240S
8	WPA-C (Screw)	20026780A	
9	Fastner	20017726A	
10	O-Ring (Φ17.5x2.7t)	20006947A	
11	Cold Inlet Pipe	30214751A	NPE-150S
		30011521A	NPE-180S
		30011665A	NPE-210S/240S
12	Fan Damper	30008825A	
13	Fan Packing	20022744A	
14	Fan Bracket (F)	20022095A	
15	Backup Ring	20018744B	
16	High Limit Switch	30002577A	
17	Fastner	20007853A	
18	WPA-A (Clip)	20018344A	
19	Thermistor	30008366A	Water
		20033191A	NPE-150S
20	WPA-B	20018343A	NPE-180S/210S/240S
		30014330A	NPE-150S
21	H-Ex Middle Pipe	30009126A	NPE-180S
		30010803C	NPE-210S/240S
		30008569A	
22	WPA-A (Screw)	30014327A	NPE-150S
		30011518A	NPE-180S
		30011514A	NPE-210S/240S
23	Mixing Pipe	20025960A	
24	WPA-T	30014328A	NPE-150S
		30011520A	NPE-180S
		30011516A	NPE-210S/240S
25	Hot Water Outlet Pipe	30014328A	NPE-150S
		30011520A	NPE-180S
		30011516A	NPE-210S/240S

6.5.4 Waterway Assembly(NPE-180A/210A/240A)

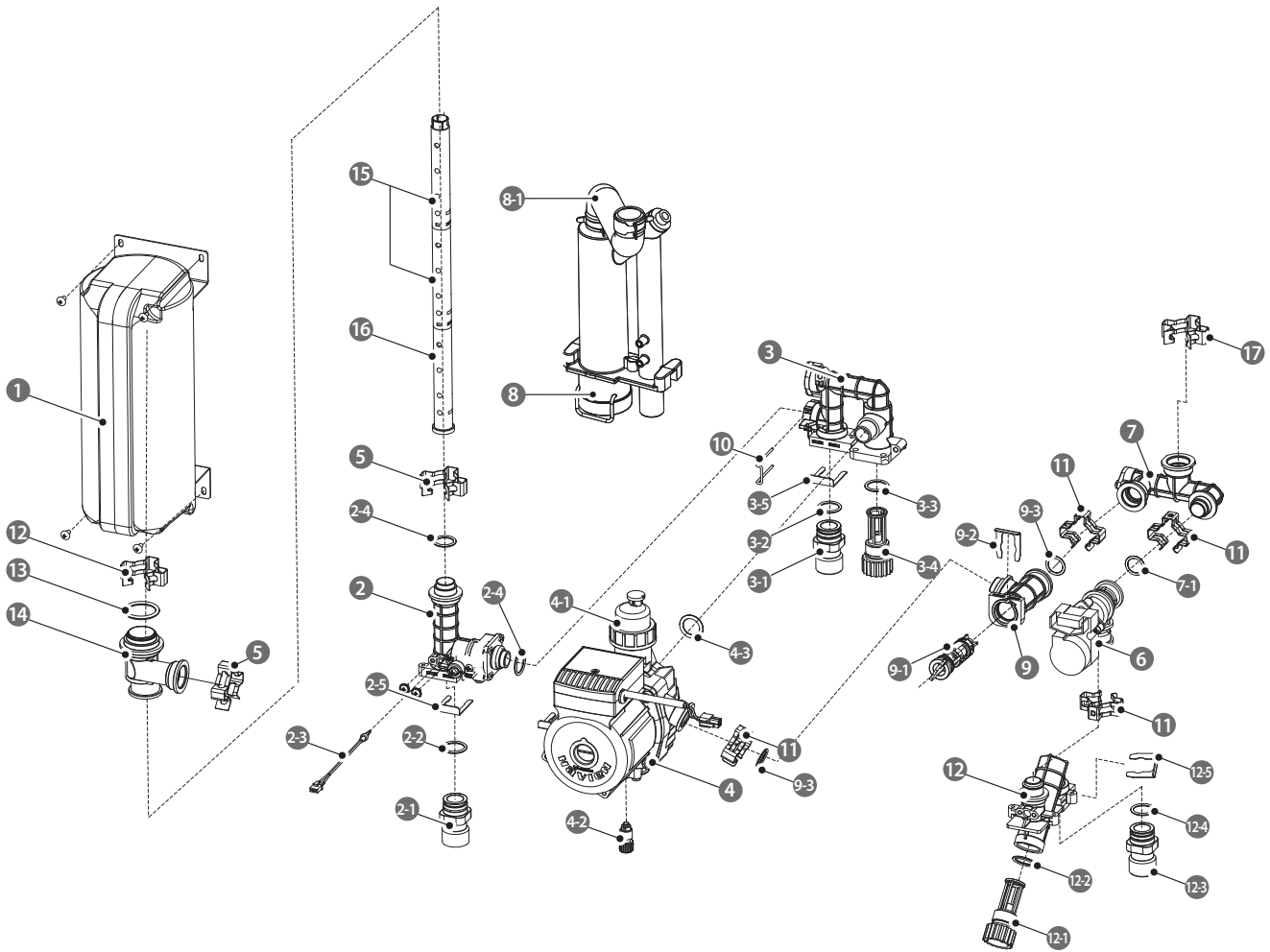

#	Description	Part #	Remark
1	Buffer Tank	30010953A	
2	Hot Water Outlet Pipe Assembly	30008338A	
2-1	Pipe Adapter	30008349A	
2-2	O-RING (P20)	20017212A	
2-3	Thermistor (Red)	30008366A	
2-4	O-RING (P16)	20006947A	
2-5	Pipe Clip	20007733A	
3	Return Pipe Assembly	30008350A	
3-1	Pipe adapter	30008349A	

#	Description	Part #	Remark
3-2	O-RING (P20)	20017212A	
3-3	O-RING (P19)	20017211A	
3-4	Water Filter	30008351A	
3-5	Pipe Clip	20007733A	
4	Circulation Pump	30010346A	
4-1	Pump Air Separator	30006831A	
4-2	Drain Plug	30003550B	
4-3	O-RING (P18)	20006947A	
5	Fastner	20017726A	
6	Water adjustment valve (WAV)	30008245A	
7	WAV Outlet Pipe Assembly	30008624B	
7-1	O-Ring (P16)	20011438A	
8	Syphon	30009756B	
8-1	Syphon Hose	20018429A	
9	Pump Outlet Pipe Assembly	30008361A	
9-1	Check Valve	30008360A	
9-2	Pipe Clip	20017722A	
9-3	O-Ring (P16)	20017210A	
10	Return Pipe clip	20017767A	
11	Fastner	20007859A	
12	Cold Water Inlet Pipe Assembly	30009437A	
12-1	Water Filter	30008351A	
12-2	O-RING (P19)	20017211A	
12-3	Pipe adapter	30008349A	
12-4	O-RING (P20)	20017212A	
12-5	Pipe Clip	20007733A	
13	O-RING (P29)	20017923A	
14	Buffer Tank adapter	20017757A	
15	Buffer tank pipe A	20017759A	
16	Buffer tank pipe B	20017760A	
17	Fastner	20017724A	

6.5.5 Waterway Assembly(NPE-180S/ 210S/ 240S)

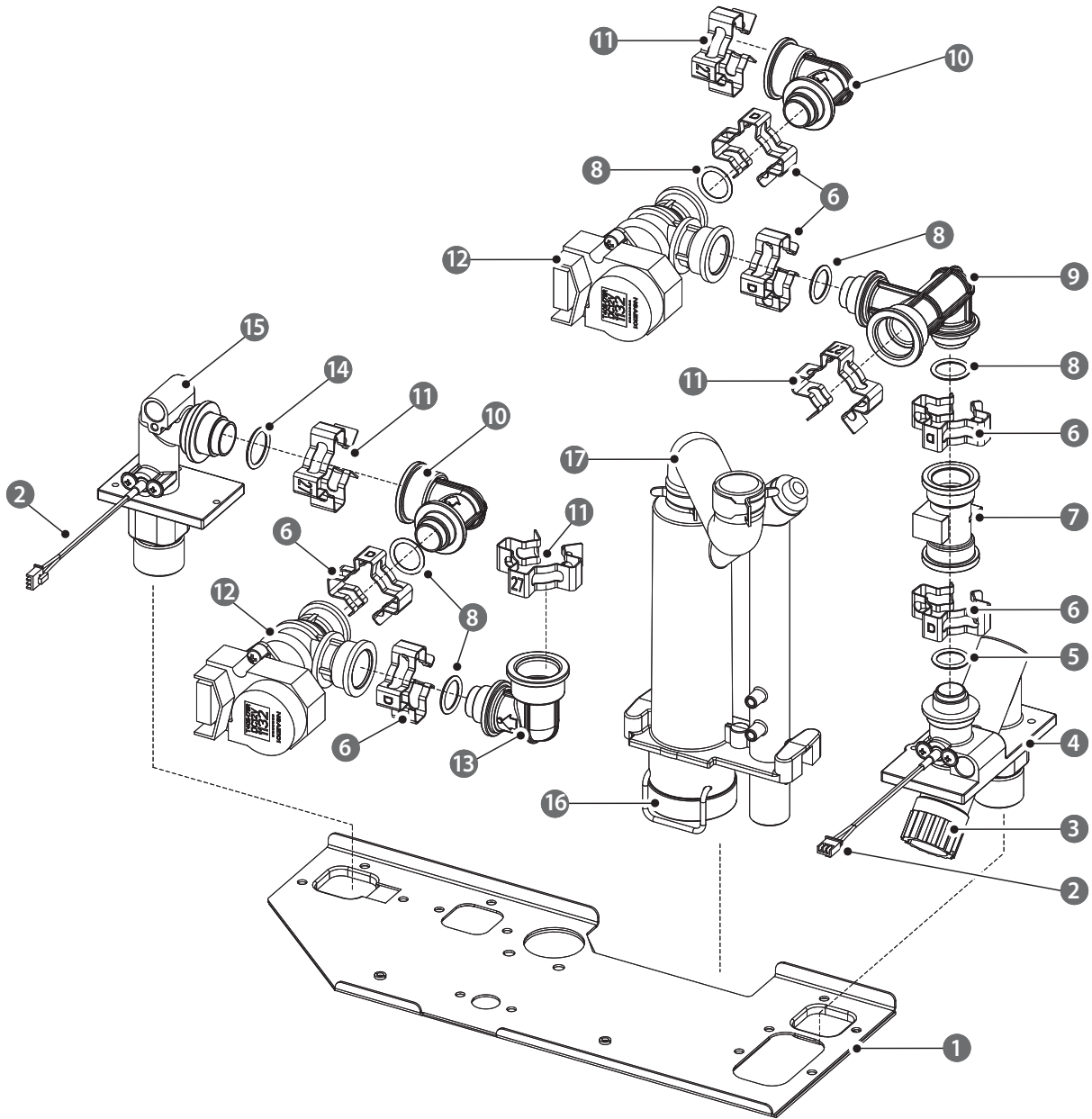

#	Description	Part #	Remark
1	Bracket	20026489A	
2	Thermistor	30008366A	
3	Water Filter	30008171A	
4	Cold Water Inlet Adapter	30011597A	
5	O-Ring (P15)	20017217A	
6	Fastner	20007859A	
7	Flow Sensor	30011534A	
8	O-Ring (P16)	20017210A	
9	Flow Sensor Outlet Adapter	20025959A	
10	Outlet Adapter	20025961A	
11	Fastner	20017726A	
12	Water Adjustment Valve (WAV)	30011532A	
13	Inlet Adapter	20025962A	
14	O-Ring (P18)	20006947A	
15	How Water Outlet Adapter	30011601A	
16	Siphon	30009756B	
17	Siphon Hose	20018429A	

6.5.6 Fan(Gas) Assembly

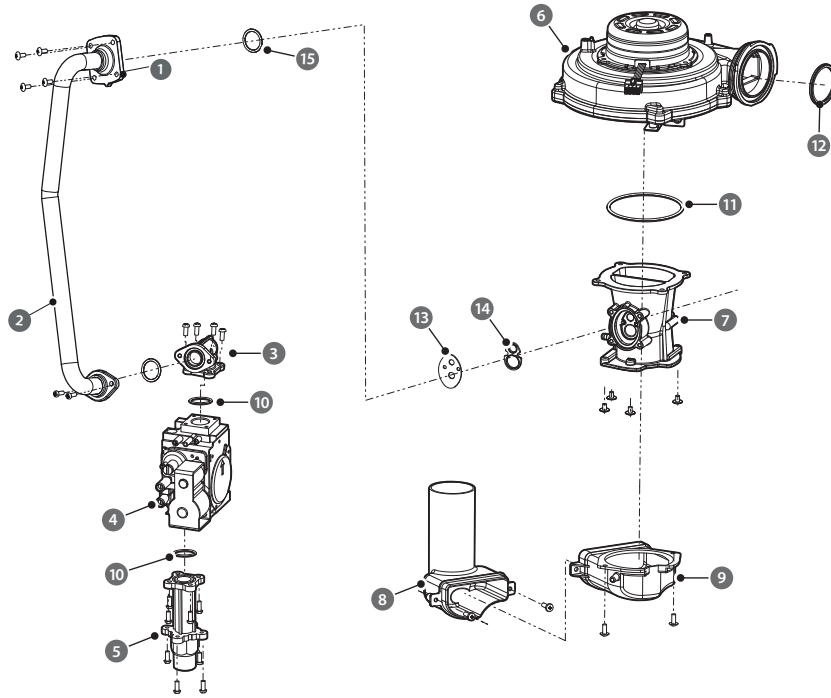

[NPE-180S/180A/210S/210A/240S/240A]

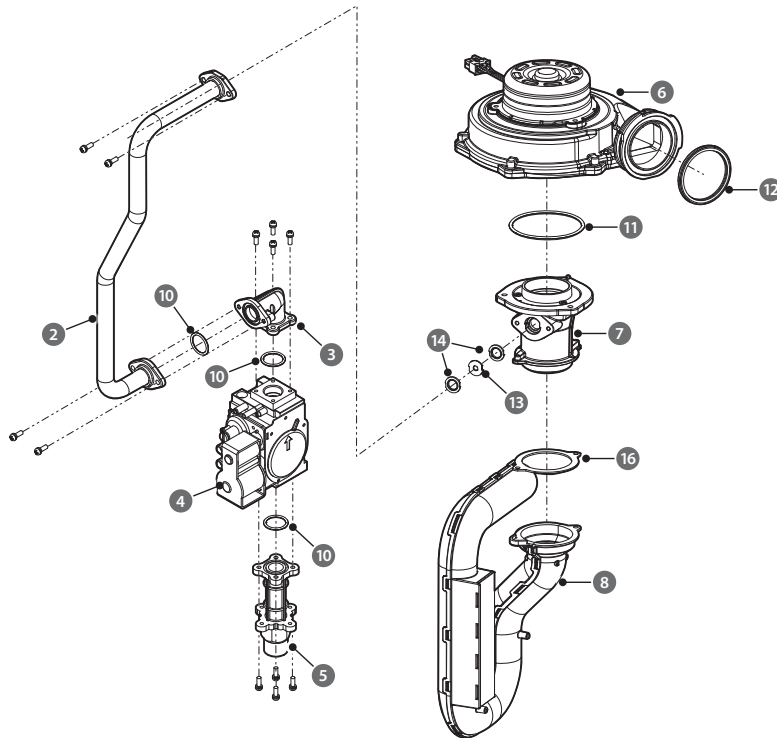

[NPE-150S]

#	Description	Part #	Remark
1	Gas Adapter	30009921A	NPE-180S/180A
		30009922A	NPE-210S/210A/240S/240A
2	Gas Pipe	30014329A	NPE-150S
		30013323A	NPE180S/180A
		30008431A	NPE-210S/210A/240S/240A
3	Gas Connector	20018430A	
4	Gas Valve	30008429A	
5	Gas Inlet Adapter	20023809A	
6	Fan Assembly	30015421A	NPE-150S
		30008834A	NPE-180S/180A/210S/210A/240S/240A
7	Single Venturi	30014688A	NPE-150S
	Dual Venturi	30009219A	NPE-180S/180A
		30008909A	NPE-210S/210A/240S/240A
8	Silence	30015322A	NPE-150S
		20019142A	NPE-180S/180A
		20023829A	NPE-210S/210A/240S/240A
9	Silence Adapter	20023861A	NPE-180S/180A
		20019141A	NPE-210S/210A/240S/240A
10	O-Ring (P20)	20006934A	
11	O-Ring (G70)	20007001A	NPE-150S
	O-Ring (G75)	20018079A	NPE-180S/180A/210S/210A/240S/240A
12	Fan Packing	20022744A	
13	Gas Orifice	20029420B	NPE-150S (NG)
		20034178A	NPE-150S (LP)
		20024159A	NPE-180S/180A (NG)
		20024190A	NPE-180S/180A (LP)
		20019144A	NPE-210S/210A/240S/240A (NG)
		20024189A	NPE-210S/210A/240S/240A (LP)
14	Venturi Packing	20030893A	NPE-150S
		20022660A	NPE-180S/180A/210S/210A/240S/240A
15	O-Ring (P34)	20019090A	NPE-180S/180A/210S/210A/240S/240A
16	Silence Packing	20032129A	NPE-150S

6.6 Installation Check list

After installing the water heater, review the following checklist. You should be able to answer “Yes” to all of the items in the checklist. If not, review the appropriate sections to complete the installation. To troubleshoot any operational problems refer to “Troubleshooting” in the Owner’s Manual.

If you have additional questions or need assistance with installation, contact Technical Support at 1-800-519-8794 or 1-949-420-0420, or refer to the technical support section of Navien’s website (www.navien.com).

Installing the Water Heater	Yes	No
Have you maintained the required clearances from building openings and intake air vents?		
Have you minimized the distance between the water heater and the vent termination?		
Have you minimized the distance between the water heater and major fixtures?		
Have you maintained the proper service and maintenance clearances?		
Is the make-up air supply sufficient for proper operation?		
Is the make-up air supply free from dust, dirt, corrosive elements, and flammable vapors?		
Is the water heater and vent piping clear of combustibile materials, including clothing, cleaning materials, and rags?		

Connecting the Gas Supply	Yes	No
Does the gas supply match the type specified on the water heater’s rating plate?		
Is the gas line at least 1/2 in or 3/4 in ID (Inner Diameter)?		
Is the gas supply line sufficient in length and diameter to deliver the required BTUs?		
Have you measured the pressure of the gas supply line?		
Is the gas supply pressure within the recommended ranges specified in this manual?		
Is the gas supply line equipped with a manual full port valve?		
Have you tested the gas line pressure and all fittings for leaks?		
Has the gas company inspected the installation, if required?		

Connecting the Water Supply	Yes	No
Is the water supply pressure sufficient (greater than 40 PSI)?		
Have you installed shut off valves on the inlet and outlet to facilitate cleaning of the inlet water filter?		
Have you bled the air out at each fixture?		
Have you checked each fixture to ensure hot water is being supplied?		
Have you cleaned the inlet water filter?		
If you installed a recirculation line, have you insulated the hot water pipes and the return line?		

Connecting a Pressure Relief Valve	Yes	No
Have you installed an approved pressure relief valve on the water heater?		
Does the rating of the pressure relief valve match or exceed the maximum BTU rating of the water heater?		
Is the pressure relief valve at least 3/4 in in diameter?		

Connecting a Pressure Relief Valve	Yes	No
Have you installed the pressure relief valve on the hot water outlet pipe near the water heater?		
Have you installed a discharge drain tube from the pressure relief valve to within 6–12 in (150–300 mm) of the floor?		

Connecting the Condensate Drain	Yes	No
Have you installed a condensate drain line from the water heater to a drain or laundry tub?		

Venting the Water Heater	Yes	No
Have you vented the water heater with 2 in or 3 in PVC, CPVC, Polypropylene, Type BH Special Gas Vent (ULC-S636) for Category IV Water Heaters (Canada), or in accordance with all local codes and the guidelines in this manual?		
Have you ensured that PVC cellular core pipe has not been used as venting for the water heater?		
Is the vent sloped upward toward the vent termination at a rate of 1/4 in per foot (2 % grade)?		
Are all vent runs properly supported?		
Have you properly supported the vent termination?		
Have you properly sealed all air intake and exhaust joints, from the flue collar to the to the vent termination?		
Have you installed end caps on the exhaust and intake pipes?		
Have you checked the venting for leaks?		
Is the vent termination at least 12 in (300 mm) above the exterior grade?		
Have you ensured that sufficient make-up air is available?		
Is the total vent length within the maximum vent length restriction?		

Connecting the Power Supply	Yes	No
Is the supplied voltage 110-120 V AC?		
Is the water heater plugged into a properly grounded outlet?		
If you have made a direct power supply connection, have you installed a power switch to facilitate end-user maintenance?		
Have you checked the polarity of the electrical connection?		
Is the system properly set up for cascade operation (master and slave water heaters), if applicable?		

Setting the DIP Switches	Yes	No
Have you verified the positions of all DIP switches on the circuit board?		
Have you verified the positions of all DIP switches on the front panel?		

Operating the Water Heater	Yes	No
Have you shown the owner how to clean the inlet water filter?		
Have you given the Installation Manual and Owner's Manual to the owner for future reference?		
Have you shown the owner how to shut off the gas in case of an emergency?		

6.7 Navien H2Air Add-on Controller Kit (Optional)

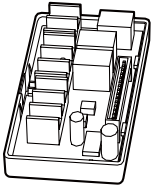

The Navien H2Air is an add-on controller for the Navien NPE-A series water heaters. It adds input and output functions to the NPE-A series water heaters for a combination application where space heating and domestic hot water (DHW) are supplied simultaneously. With this add-on controller, a thermostat (1 or 2-stage) and an outdoor sensor can be installed along with a hydronic air handler to add space heating functionality to the system.

CAUTION

This device is designed to work with the NPE-A series models ONLY.

Basic Principles

The following diagram shows the basic operation of an NPE-A series water heater system with the Navien H2Air add-on controller.

CAUTION

Do not configure the system for DHW recirculation when it is configured to run an air handler using the H2Air add-on controller. DHW recirculation and Navien H2Air configurations cannot be used at the same time.

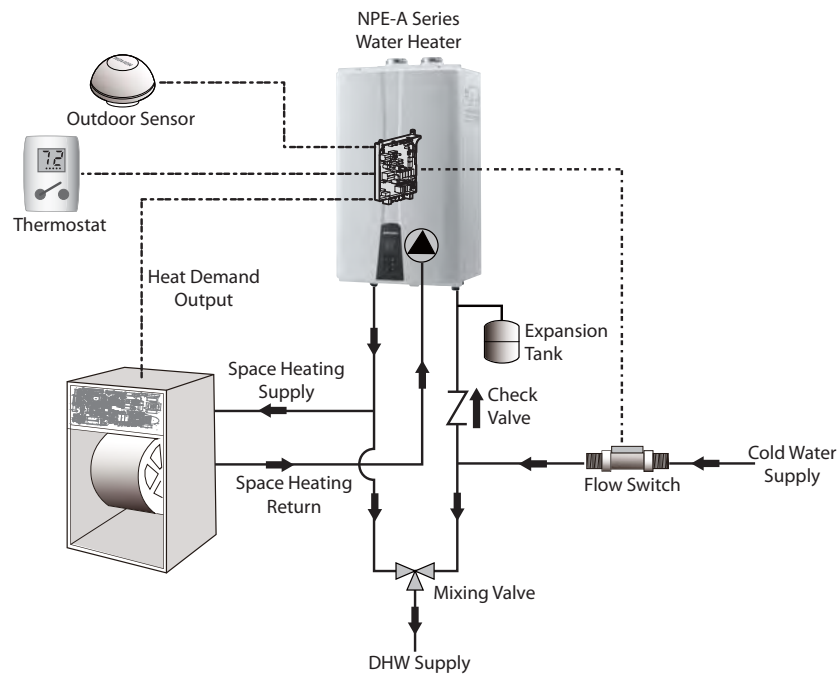

For details, refer to the installation manual that is provided with the H2Air add-on controller kit.

6.8 Navien HotButton Kit (Optional)

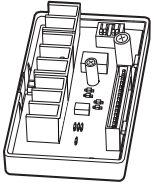

The Navien HotButton kit is an add-on input board for the Navien NPE-A series water heaters. It adds signal input functions to the NPE-A series water heaters for more efficient DHW hot water recirculation functionality.

With the HotButton kit, DHW recirculation is carried out exactly when the actual demands arise. This prevents energy loss caused by unnecessary operation of the burner and pump throughout the day.

The HotButton kit can receive signals from multiple push buttons installed in various areas and performs optimal DHW recirculation only when there is a demand for hot water.

⚠ CAUTION

This device is designed to work with the NPE-A series models ONLY.

Basic Principles

The following diagram shows the basic operation of an NPE-A series water heater system with the Navien HotButton kit.

⚠ CAUTION

The Navien HotButton can be used ONLY with a water heater system configured for DHW recirculation.

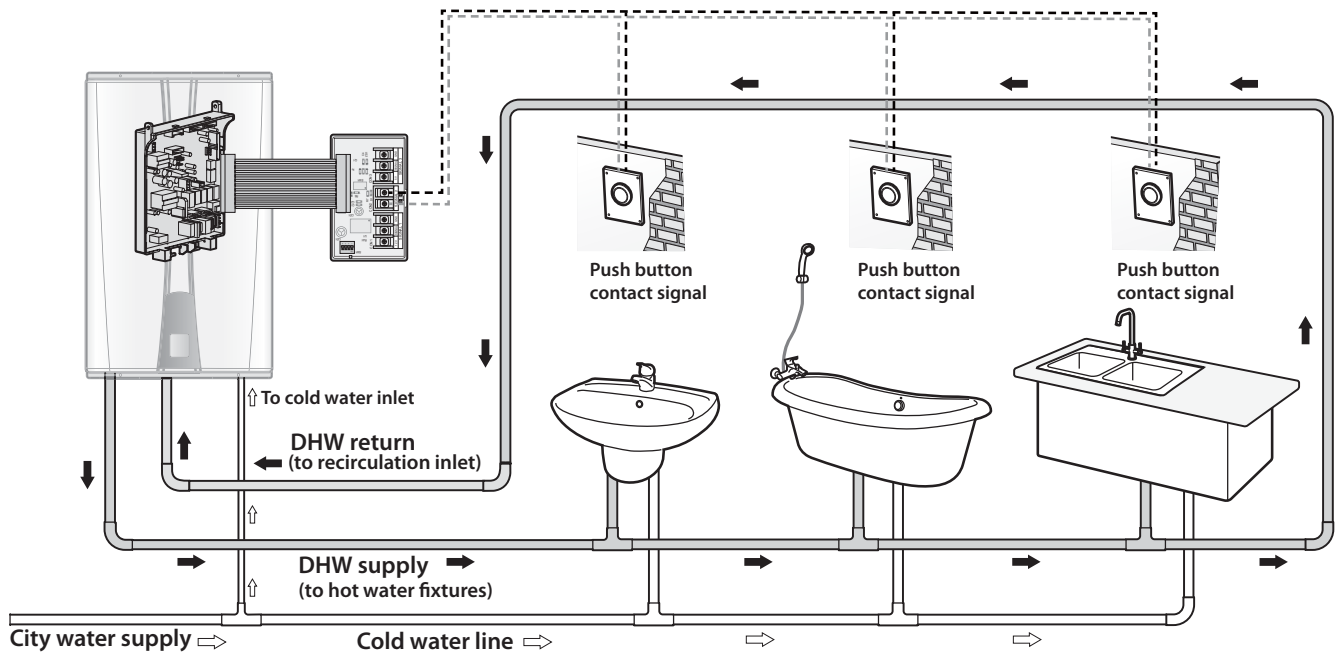

For details, refer to the installation manual that is provided with the HotButton kit.

6.9 Requirements for the State of Massachusetts

NOTICE BEFORE INSTALLATION

This appliance must be installed by a licensed plumber or gas fitter in accordance with the Massachusetts Plumbing and Fuel Gas Code 248 CMR Sections 4.00 and 5.00.

IMPORTANT: In the State of Massachusetts (248 CMR 4.00 & 5.00)

For all side wall horizontally vented gas fueled equipment installed in every dwelling, building or structure used in whole or in part for residential purposes, including those owned or operated by the Commonwealth and where the side wall exhaust vent termination is less than seven (7) feet above finished grade in the area of the venting, including but not limited to decks and porches, the following requirements shall be satisfied:

1. **INSTALLATION OF CARBON MONOXIDE DETECTORS.** No installation or replacement of a vented gas appliance shall be permitted unless a battery powered or electrically hard wired carbon monoxide detector is present on the same floor as the appliance or on the next adjacent floor when the appliance is located in a crawl space unless the appliance is located in a detached, uninhabitable garage. For all residential dwellings, a carbon monoxide detector must also be present on each habitable level of the dwelling. These requirements shall not be deemed to waive any additional requirements imposed by M.G.L. c. 148 §26F1/2.
2. **APPROVED CARBON MONOXIDE DETECTORS.** Each carbon monoxide detector as required in accordance with the above provisions shall comply with NFPA 720 and be ANSI/UL 2034 listed and IAS certified.
3. **SIGNAGE.** Whenever any through-the-wall vent is installed less than seven feet above the finished grade, a metal or plastic identification plate shall be permanently mounted to the exterior of the building at a minimum height of eight feet above grade directly in line with the exhaust vent terminal. The sign shall read, in print size no less than 0.5 inches in size, **"GAS VENT DIRECTLY BELOW. KEEP CLEAR OF ALL OBSTRUCTIONS"**.
4. **INSPECTION.** The state or local gas inspector of the side wall horizontally vented gas fueled equipment shall not approve the installation unless, upon inspection, the inspector observes carbon monoxide detectors and signage installed in accordance with the provisions of 248 CMR 5.09 and 5.12.

Memo

Installation Manual

NPE Condensing Water Heaters

Getting Service

If your water heater requires service, you have several options for getting service:

- Contact Technical Support at 1-800-519-8794 or on the website: www.navien.com.
- For warranty service, always contact Technical Support first.
- Contact the technician or professional who installed your water heater.
- Contact a licensed professional for the affected system (for example, a plumber or electrician).

When you contact Technical Support, please have the following information at hand:

- Model number
- Serial number
- Date purchased
- Installation location and type
- Error code, if any appears on the front panel display

Version: 5.3 (Feb. 25, 2016)



Navien, Inc.
800.519.8794 www.Navien.com
20 Goodyear, Irvine, CA 92618