



Dual VELOCITY™ Toaster

Owner's Manual

WARNING:

Improper installation, adjustment, alteration, maintenance can cause property damage, injury, or death. Read the installation, operating and maintenance instructions thoroughly before installing or servicing this equipment.

FOR YOUR SAFETY:

Do not store or use gasoline or other flammable vapors or liquids in the vicinity of this or any other appliance.

Toaster must be kept free of combustible materials, and the flow of ventilation air must not be obstructed. Operating personnel must not perform any maintenance or repair functions. Contact your Nieco Authorized Dealer for service or repair.

IMPORTANT: RETAIN THIS MANUAL IN A SAFE PLACE FOR FUTURE REFERENCE

TABLE OF CONTENTS

General Information	3
Operating Instructions	4
Programming Recipes and Manager Settings Overview	5
Cleaning and Maintenance, Equipment Use & Care	6
Site Preparation and Installation, Clearance Requirements.....	7
Electrical Safety, Work Area Reminders, Service Information.....	8
Wiring Diagram.....	9
Warranty.....	10
Specifications	12



The Nieco Dual Velocity™ Rapid Forced-Air Toaster: The Next Generation Of Toasting Technology

With all new Smarter Controller technology and Next Generation energy savings, the VELOCITY™ is engineered to help you conserve and save 10–20% on energy use, without sacrificing rapid service.

FEATURES

- High speed—perfectly toasts bakery products like bagels, bread, croissants and English muffins in just seconds, with 10% less energy consumption.
- Nieco's programmable touch screen Smarter Controller technology supports easy operation with advanced features that save and make you money.
- Dual toast belts with precision Touch Screen controls offer greater product flexibility with fewer adjustments. Easy to use, perfect product toast settings.
- Programmable Low Energy Mode—reduce your energy use during off-peak service hours while still maintaining toasting output for an additional 10% energy savings
- Simple clean-up of crumbs and melted cheese with removable exit slide.
- Sturdy all stainless-steel construction; no quartz glass elements means a longer-life and fewer parts for replacement.
- Control and voltage indicator notifies if wall voltage is out of spec for the unit, to ensure optimal operation performance and prevent damage.

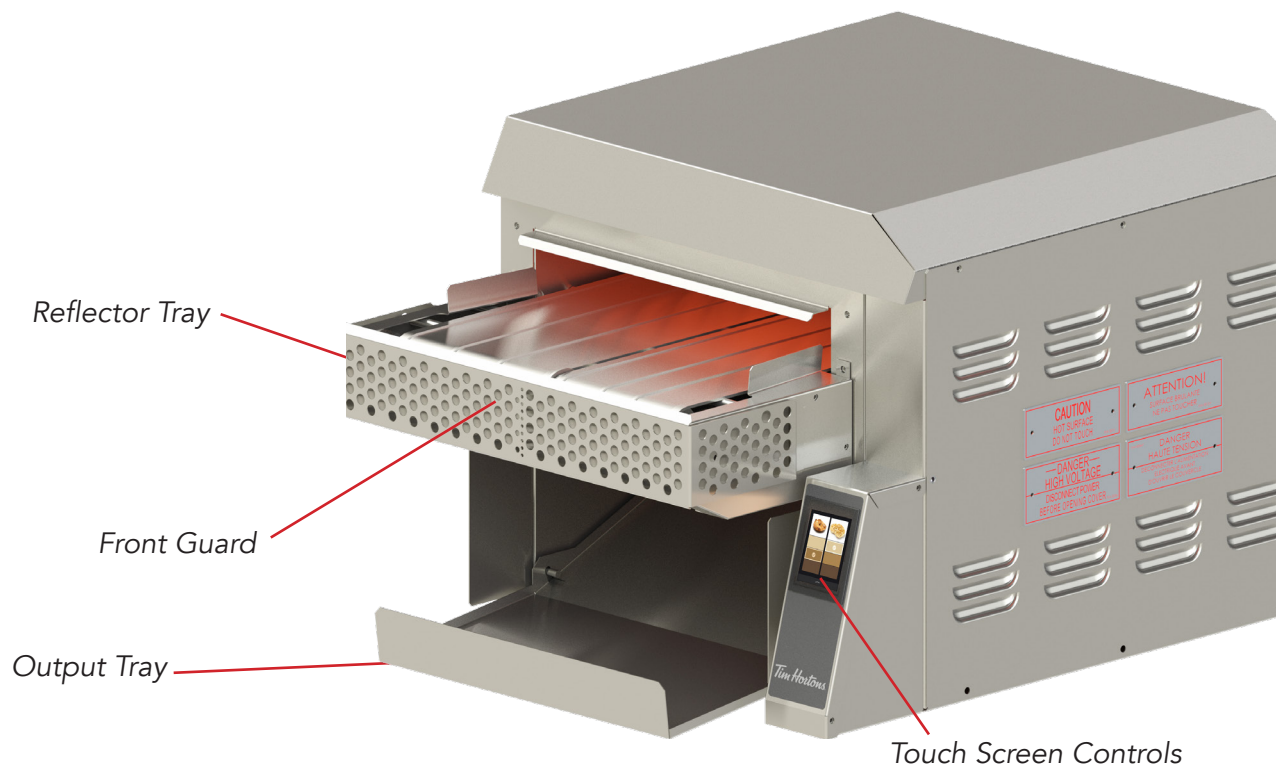

CAUTION

- Toaster surfaces are hot while operating. Touching hot surfaces can cause serious personal injuries including burns. This toaster is designed to toast bread items only. It is not designed to heat or toast protein-laden or grease/fat-laden food products, such as meat sandwiches or buttered toasts. Failure to follow these guidelines may result in fire.

DO NOT UNPLUG THE TOASTER WHILE THE BLOWER IS ON, EXCEPT IN CASE OF EMERGENCY!

OPERATING INSTRUCTIONS

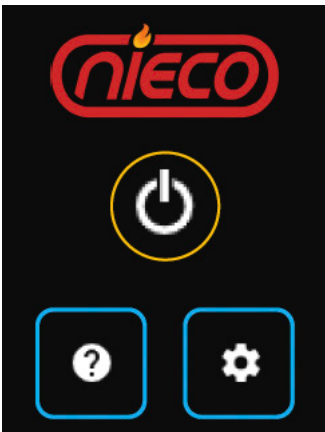

Power Menu

Touch Power symbol to power toaster blowers on or off, and access Main Menu Toast options.

Touch Help symbol to access available Help information options.

Touch Settings symbol to access Manager or Factory setting options.

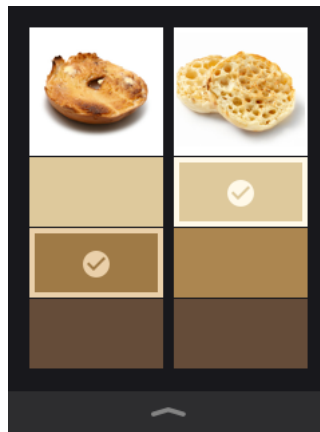

Main Menu

Shows current Toast product and level selections for Left and Right Lane.

Touch Product Image in top row to select from available menu of recipes to cook on that lane.

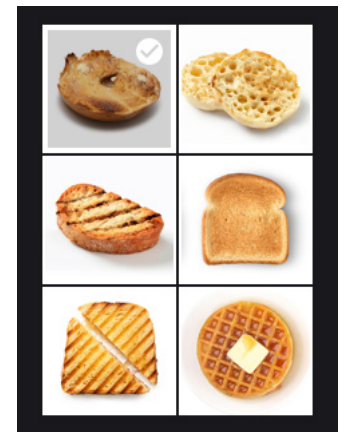

Product Recipe Menu

Displays programmed recipe options available for Selected Toast Lane.

Default toast level for a selected product is Medium. Tap the lighter or darker setting to adjust.

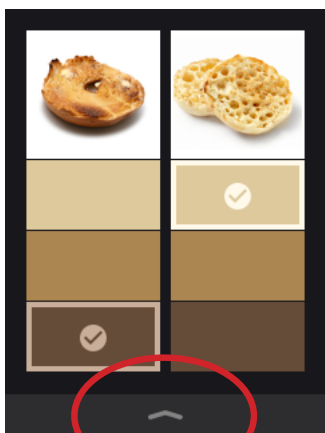

Tap to access Power Menu

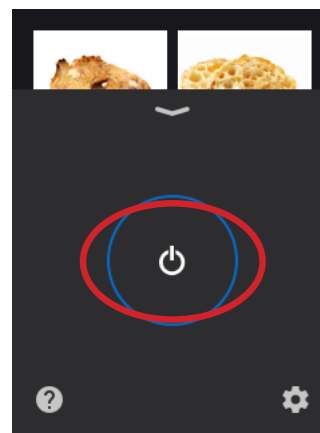

Touch Power symbol to turn off power to toaster belts and cool for cleaning.

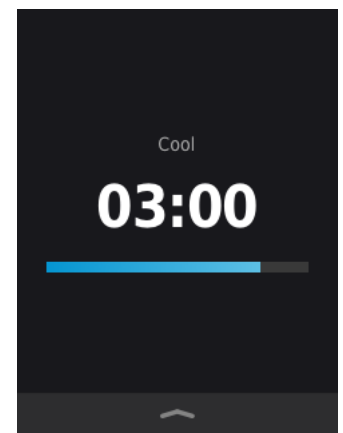

Timer indicates estimated time remaining until toaster is safe to clean.

SETTINGS

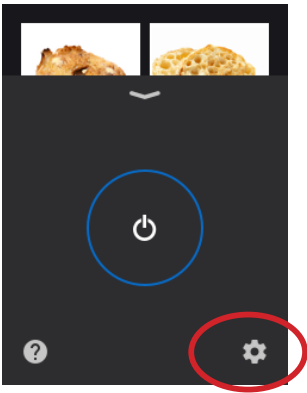

Tap the Gear icon in the lower right to access Settings.

Password: 1964

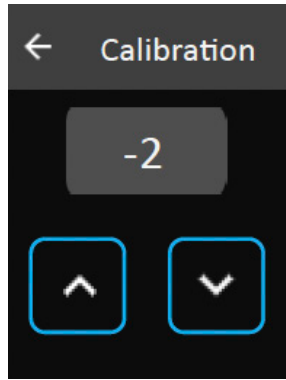

Calibration Number

Calibration value in seconds is added to any active recipe, after all other features, including Energy Mode. Default setting is 0.

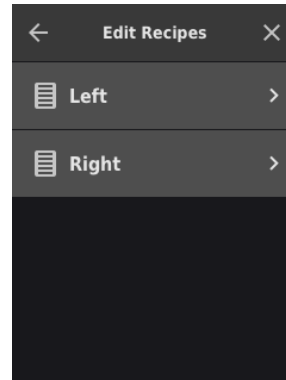

Edit Recipe Menu

Belt Select Menu

Tap Left or Right to select belt for Recipe.

- Back arrow returns user to Edit Recipe Menu
- New selections are always saved when exiting.

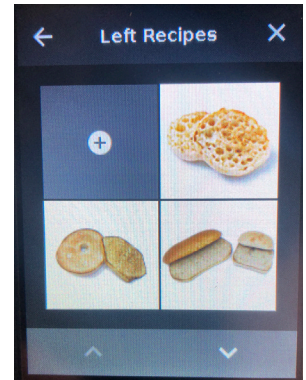

Edit Recipe

Select the product you wish to edit or add a new product

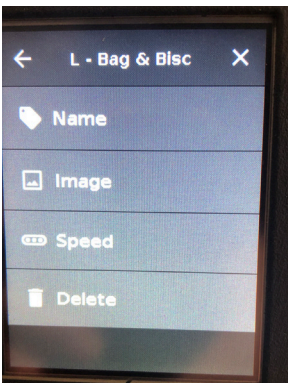

Edit Recipe Menu

Use arrows to select parameters to edit.

Default parameters:
Name,
Image,
Speed, or
Delete Product

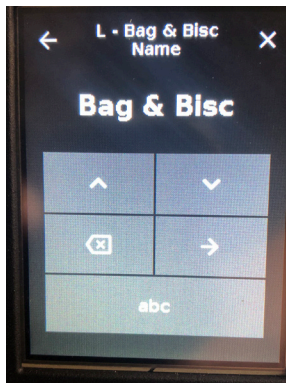

Edit Name Menu

Use arrows to select parameters to edit.

- Tap Up and Down arrows to select alphabet/numbers and change the character above the blinking cursor.
- Backspace clears last character entered.
- Back arrow returns user to Edit Recipe Menu
- New selections are always saved when exiting.

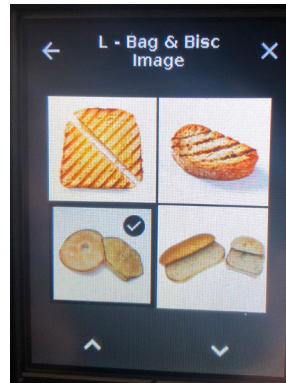

Edit Recipe Image

Use arrows to select Image.

- Tap Up and Down arrows to scroll through available image options
- Back arrow returns user to Edit Recipe Menu
- New selections are always saved when exiting.

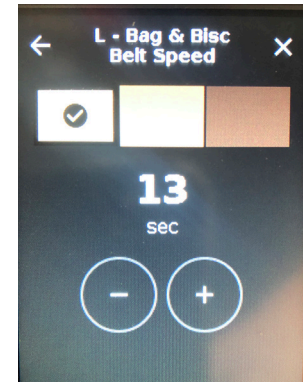

Edit Toast Speed

Use arrows to select parameters to edit.

- Choose Toast Shade to Edit Speed
- Enter belt speed
- Back arrow returns user to Edit Recipe Menu
- New selections are always saved when exiting.

MANAGER SETTINGS

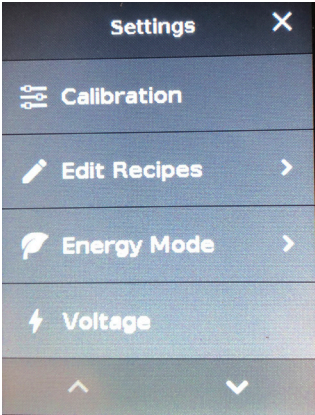

Manager Setting Menu

Use arrows to adjust settings

- Select setting to adjust
- Back arrow returns user to Manager Settings Screen
- New selections are always saved after exiting.

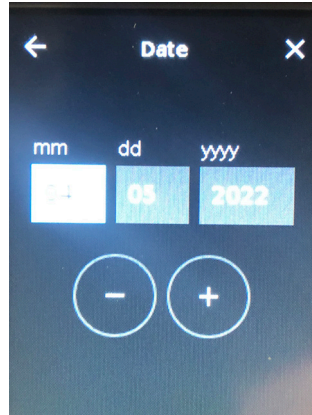

Set Current Date

Use arrows to adjust month, day, or year value.

Display Format may be changed.

mm/dd/yyyy
dd/mm/yyyy

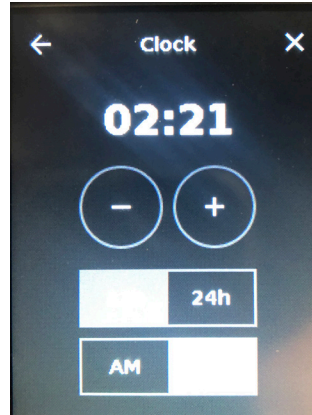

Set Time of Day

Use arrows to adjust time

- Back arrow returns user to Manager Settings Screen
- New selections are always saved after exiting.

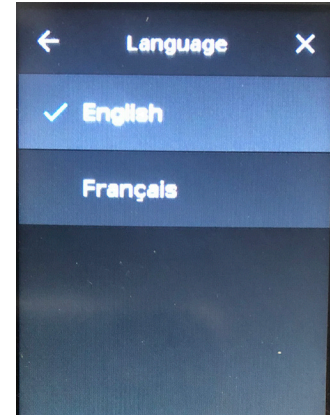

Set Language

Use arrows to select language

- Back arrow returns user to Manager Settings Screen
- New selections are always saved after exiting.

INFORMATIONAL SCREENS

These diagnostic screens access information that may be needed in troubleshooting or service.

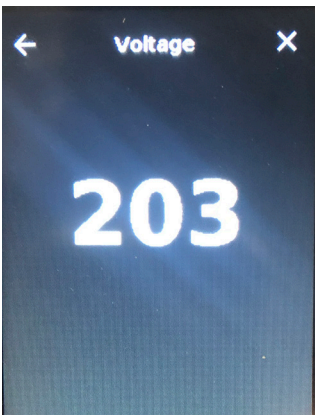

Voltage

Displays the current voltage incoming to the toaster.

Voltage that is substantially higher or lower than the rated 208V may affect toaster performance.

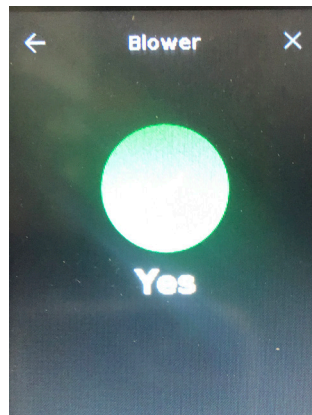

Blower

This screen displays whether the toaster blower is currently on or off.

Note: this does not allow the user to turn the blower on or off.

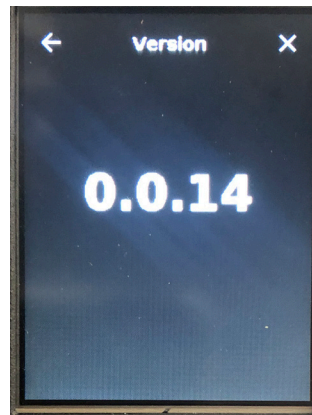

Version

Displays current software version.

SETTINGS: ENERGY MODE

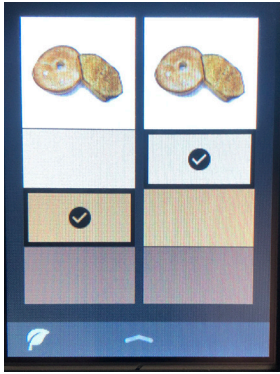

Leaf is displayed when Energy Mode is on.

Tap the arrow bottom center of screen to access the power screen.

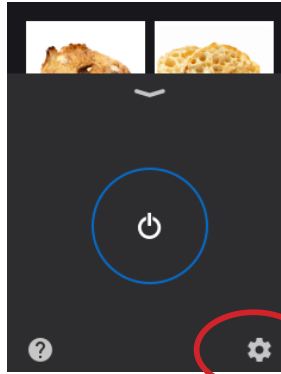

Tap the Gear icon in the lower right to access Settings.

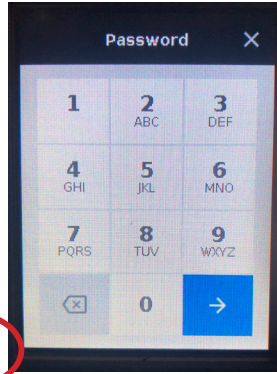

Enter password to enter settings menu.
Password: 1964

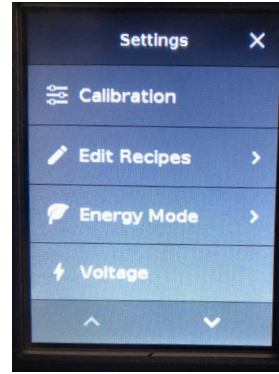

Select the Energy Mode menu.

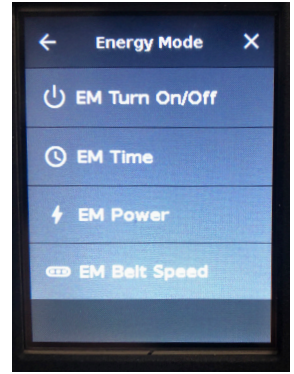

From the Energy Mode menu the feature can be; turned on or off, times can be scheduled, power adjusted, belt speeds adusted.

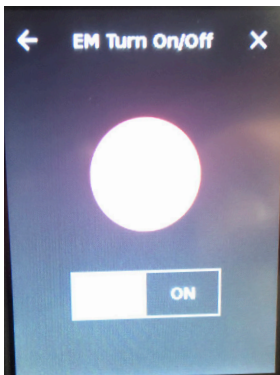

Energy Mode feature can be turned off or on from this screen.

When feature is on, circle will light green and leaf will display on home screen.

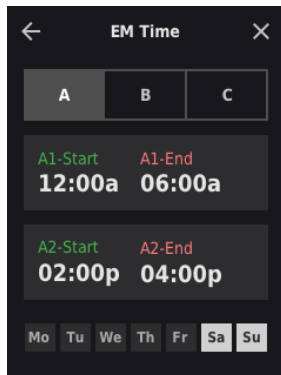

The Energy Mode Time Menu allows for three different schedules to be programed.

Each schedule can be programmed with up to two intervals and selection of days of week.

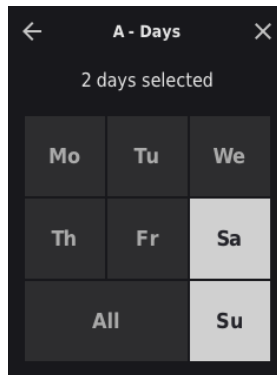

Any combination of days per week can be selected.

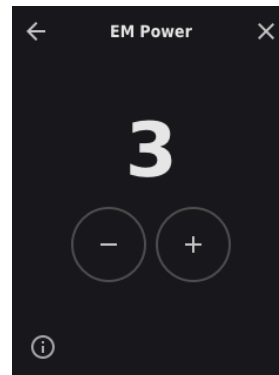

The Power Menu allows for decrease in power while unit is in Energy Mode.

The higher the number the more power will be decreased.

The maximum decrease in power will be at value 20.

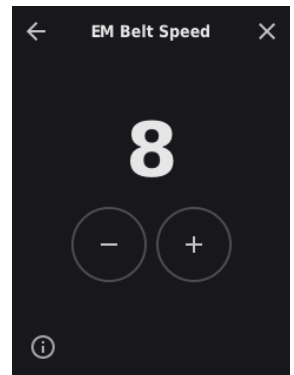

Belt Speed Menu is for the adjustment of belt speed in Energy Mode.

The higher the number the more the belt speed will slow.

The highest value is 40.



Dual VELOCITY™ Toaster

Changing Toaster Control Location

The Nieco Dual VELOCITY Toaster is designed to allow a technician to change the location of the toaster controls to best suit the position and operation of the toaster in the kitchen. This process should only be performed by a trained technician.

Instructions

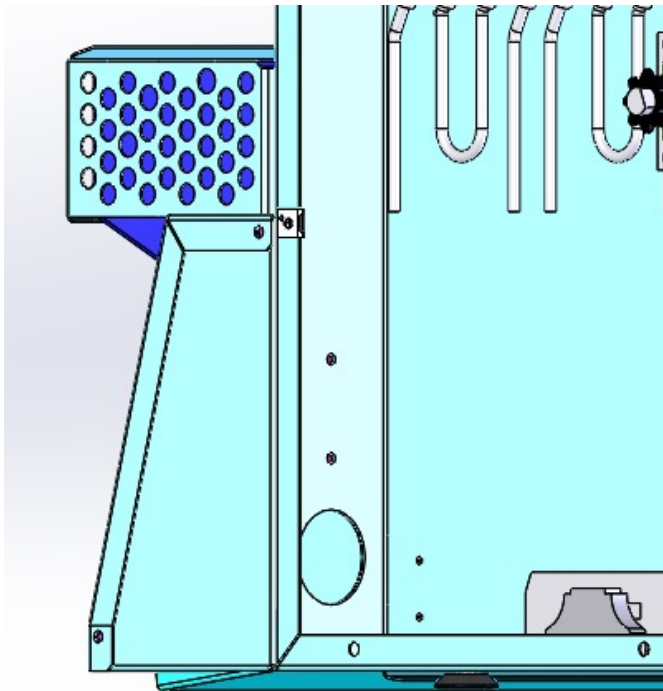

Remove side and back cover.

Unscrew box with touch screen from box with elements.

Unscrew touch screen box and detach electrical connections making note of which motor cable plugs into which spot on the control board.

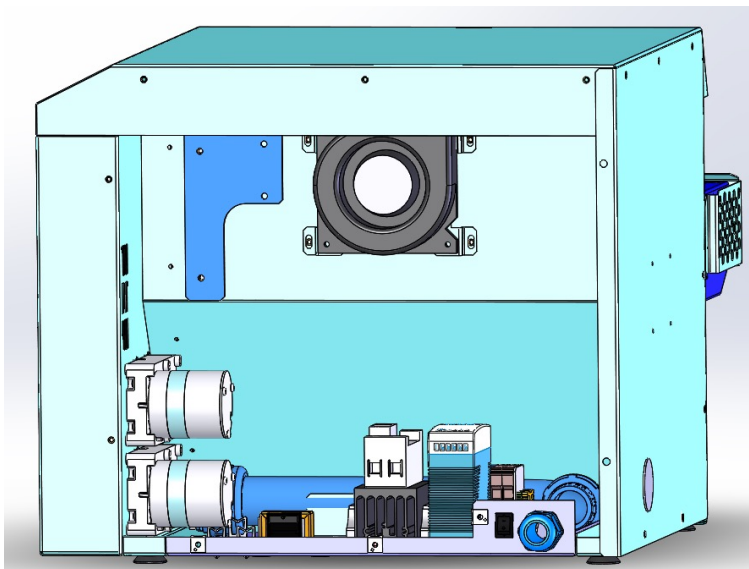

Remove snap in plug from side and install in front.

Remove extra bracket and stored flex conduit from back of toaster.



Dual VELOCITY™ Toaster Changing Toaster Control Location

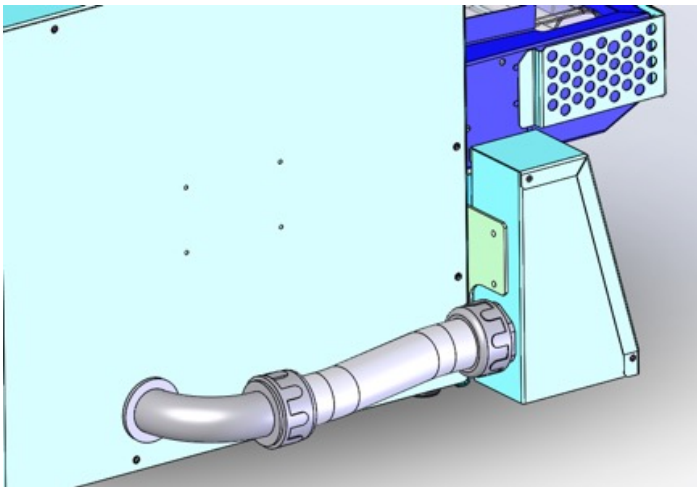

Install conduit fitting into side of toaster and back on electrical box.

Pass wires through conduit and re-attach to control board.

R4

Assemble control box and install to front of toaster.

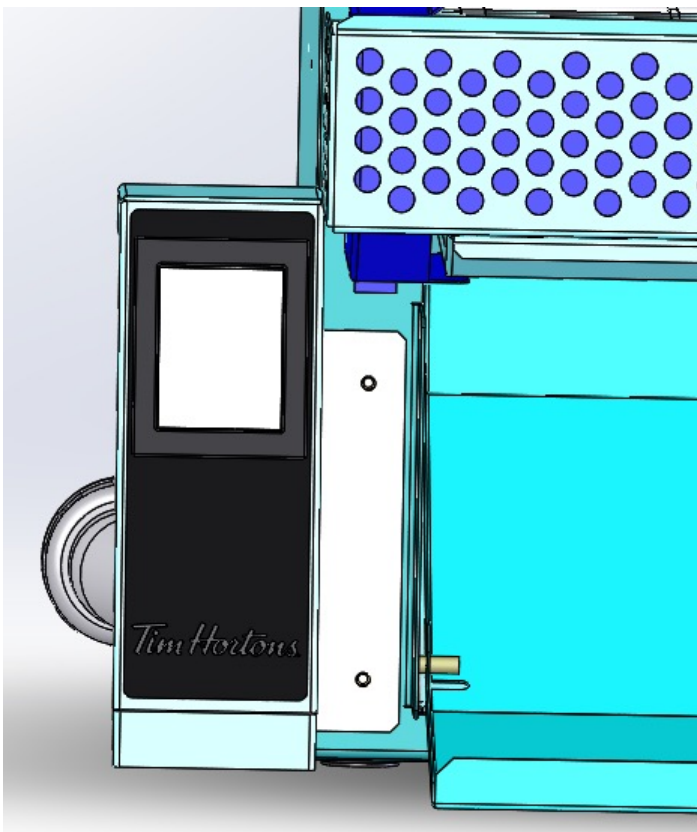

Install any remaining covers that were removed.

Power unit on and check that the belts are controlled by the proper motor.

CLEANING & MAINTENANCE

Allow toaster to cool completely. Then clean according to the steps below.

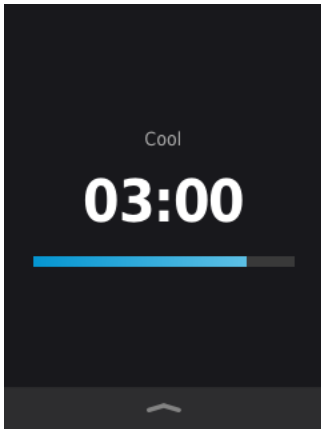

Screen will indicate when Toaster is safe to clean.



Use the cleaning brush to clean wire belt. As needed, lift belt to access other areas.



Remove the reflector tray.



Remove the output tray.



Wipe the cavity of the toaster.

EQUIPMENT USE & CARE

- Stay alert, watch what you are doing and use common sense when using equipment. Do not use equipment while you are tired or under the influence of drugs, alcohol or medication. A moment of inattention while operating equipment may result in serious personal injury.
- Avoid touching hot metal parts. Do not stand or sit on equipment. This could result in serious personal injury including burns.
- This equipment is not intended for use by persons with reduced physical, sensory or mental capacities. Do not allow persons unfamiliar with the equipment or these instructions to operate. Use of equipment by such persons could result in a hazardous situation.
- Do not overreach. Keep proper footing and balance at all times. This enables better control of the equipment in unexpected conditions.
- Do not use the equipment if the switch does not turn it on or off. Any equipment that cannot be controlled with the on/off switch and controls is dangerous and must be repaired.
- Disconnect the plug from the power source before making any adjustment or cleaning the equipment. This may result in increased risk of electric shock.
- Do not use any accessory or attachment not recommended by Nieco. Do not operate equipment on its side or inverted. Do not introduce foreign objects into equipment. Use of equipment other than intended use could result in a hazardous situation.
- Maintain the equipment. Check for breakage of cords, plugs and other parts that may affect the equipment's operation. If damaged, have the equipment repaired before use. Many accidents are caused by poorly maintained equipment.
- Use the equipment in accordance with these instructions and in the manner intended, taking into account the working conditions and work to be performed. Use of the equipment for operations different from those intended could result in a hazardous situation.

SITE PREPARATION AND INSTALLATION

This equipment is built to comply with applicable standards for manufacturers, including approval agencies, such as ETL. Many local codes exist, and it is the responsibility of the owner and installer to comply with these codes.

Check the electrical rating label to ensure that the equipment is connected to the correct voltage, phase, amperage and wattage that are stated on the equipment's identification label. The identification label is located on the back plate of the equipment. A secondary label is included inside the equipment's back plate. This equipment should be connected to a power supply that is 208 Volts, 60 Hz, AC only. Do not operate on direct current (DC). A substantial voltage drop will cause a loss of power and may damage the equipment. If the equipment does not operate when plugged into an outlet, check the power supply.

Observe all clearance requirements to provide air supply for proper operation, as well as sufficient clearance for servicing. Keep the area around the equipment free and clear of combustibles. Dimensions and clearance specifications are shown under "Specifications for Dual VELOCITY™ Toaster Ex6350" and "Clearance Requirements for Dual VELOCITY™ Toaster Ex6350".

WARNING: The installation and connection must comply with national and local electrical codes. Ensure electrical supply conforms with electrical characteristics shown on the identification label. All services must be performed by a qualified technician.

WARNING: Keep cord clear of the working area. Position the electric cord so that it will not get caught on other equipment or interfere in work space. Failure to do so can result in serious personal injury.

WARNING: Check cords before each use. If damaged, replace immediately. Never use equipment with a damaged cord since touching the damaged area could cause electrical shock resulting in serious injury.

CLEARANCE REQUIREMENTS for Nieco Dual VELOCITY™ Toaster Ex6350

This equipment must be installed in accordance with the following minimum clearances in order to provide proper operation and servicing of the appliance.

Also, it is recommended that the equipment be installed with sufficient clearances to provide proper cleaning and maintenance.

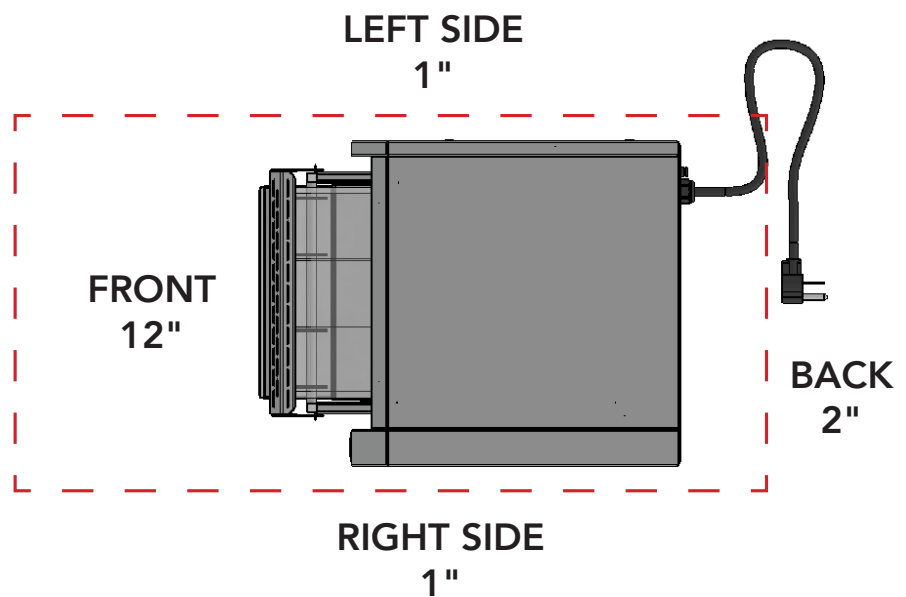

ELECTRICAL SAFETY

- Equipment supplied with cord & plug (6-30P). Ensure plug matches the outlet. Never modify the plug in any way. Do not use any adapter plugs. Modified plugs and non-matching outlets will increase the risk of electric shock.
- Avoid body contact with earthed or grounded surfaces such as pipes, radiators, ranges, refrigerators and other foodservice equipment. There is an increased risk of electric shock if your body is earthed or grounded.
- Do not expose equipment to wet conditions. Do not immerse cord, plug or equipment in water or other liquids. Water or other liquids entering equipment will increase the risk of electric shock.
- Do not abuse the cord. Do not yank cord to disconnect from power outlet. Never use the cord for carrying, pulling or unplugging the equipment. Keep cord away from heat, oil, sharp edges, moving parts or the end of table or counter. Damaged or entangled cords increase the risk of electric shock.

EXTENSION CORD

- Do not use an extension cord with this product. Use of an extension cord could violate local code and create a fire hazard.

WORK AREA

- Keep work area clean and well lit. Cluttered or dark areas can increase the likelihood of accidents.
- Do not set liquids on or near equipment. Liquids entering equipment will increase the risk of electric shock.
- Do not cover equipment or stack other objects on top of equipment.
- Unattended items on equipment can increase the risk of fire.
- Do not use equipment outdoors. Outdoor conditions can increase the risk of electrical shock.
- Do not place equipment on or near a hot gas or electric burner or in a heated oven.
This creates an increased risk of fire and electric shock.

SERVICE

- Have equipment serviced by a qualified repair person using only identical replacement parts. This will ensure that the safety of the equipment is maintained.
- When servicing equipment, use only authentic OEM replacement parts. Follow instructions in the maintenance section in this manual. Use of unauthorized parts or failure to follow maintenance instructions may create a risk of shock or injury.

WIRING DIAGRAM

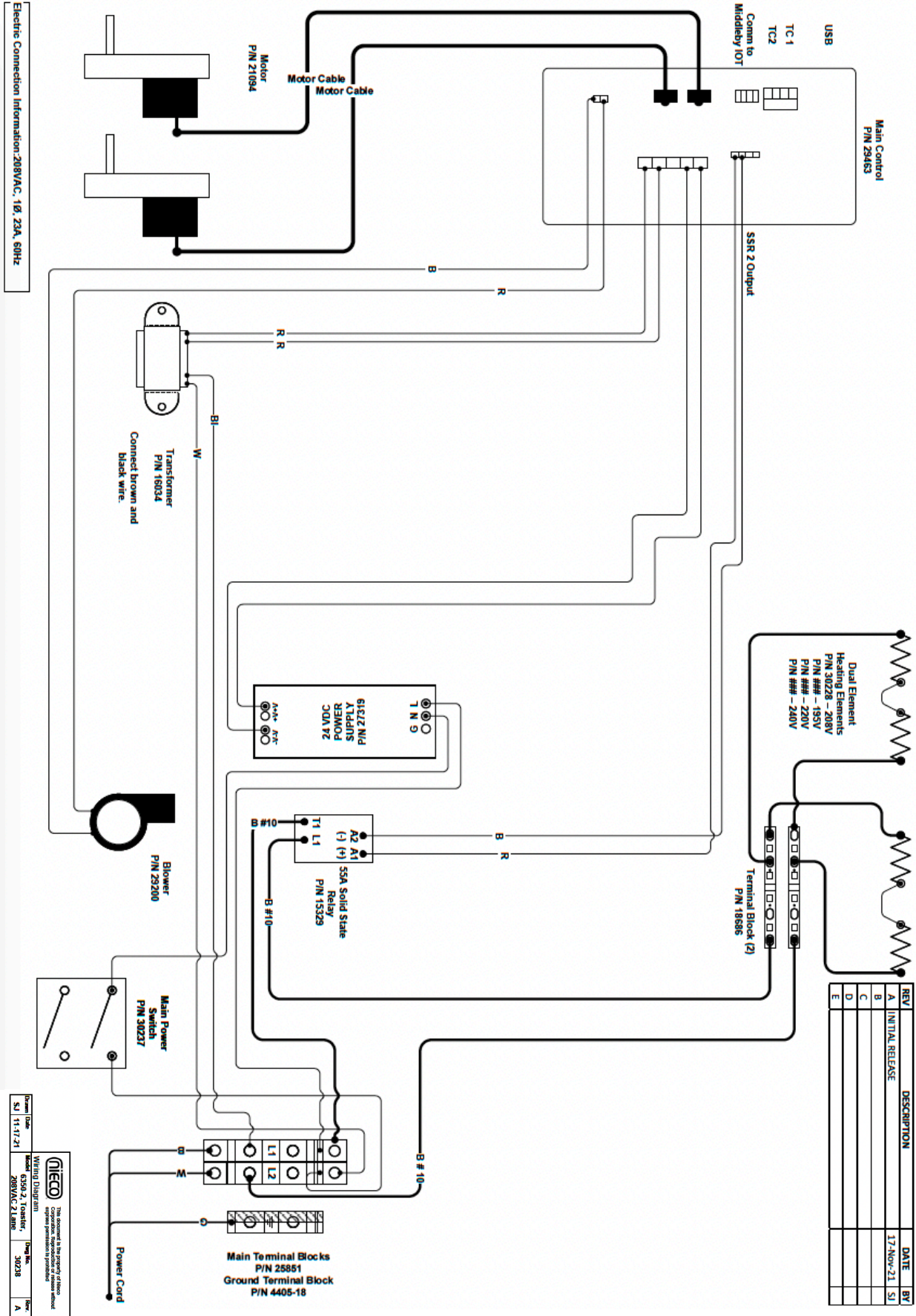

REV	DESCRIPTION	DATE	BY
A	INITIAL RELEASE	17-Nov-21	SI
B			
C			
D			
E			

NiCO
 The power is the property of NiCO.
 Copyright, reproduction or distribution
 without permission is prohibited.

WINDU Distribution
 Model: 6390-2 Toaster
 208VAC 21amps
 Part No.: 30238
 Rev: A

Drawn Date: SI 11-17-21

IMPORTANT

Nieco reserves the right to change specifications and product design.

Such revisions do not entitle the buyer to corresponding changes, improvements, additions or replacements for previously purchased equipment.

NIECO DUAL VELOCITY™ TOASTER WARRANTY

This warranty is effective for all Nieco Toasters shipped after November 1, 2021.

Your new Nieco Dual Velocity Toaster is guaranteed against original defects in manufacture of machine and component parts. This guarantee is as follows:

- All parts and labor are guaranteed for 2 years except elements as defined below.
- Elements are guaranteed for two years against any failure, whatever the cause.
- Elements replacement labor is included for one year, the second year is parts only.
- Your warranty will begin either on the date you return the Nieco warranty card that is shipped with your machine or submit install date on-line thru the Nieco website. If no registration is submitted the warranty will expire 36 months after the manufacturing date.

Generally, your guarantee provides replacement of all parts, which fail due to defects in manufacture for one year after installation of the toaster and validation of the warranty as described above. The Nieco Service provider in your area will replace parts that fail. If the part is one listed below, your Servicer will provide the labor to replace it, subject to certain conditions. The parts that will be replaced are generally parts that require service level installation or adjustment. The parts that may be replaced are listed in the Warranty Parts schedule included. Alternately, at Nieco's discretion, your machine may be swapped for a new or factory reconditioned toaster.

Nieco guarantees the correct mechanical operation of the equipment at the time of installation. Nieco makes no warranty, expressed or implied of toasting effect or of exact capacity as subjective judgments, product variations and or customer caused machine conditions beyond Nieco's ability to predict or control may alter the toasting performance of the machine.

Nieco specifically does not warrant or guarantee or provide compensation for any lost production, lost product, lost labor or lost sales or other consequential damages that may occur as a result of equipment malfunction or failure. This disclaimer of liability for consequential damages applies whether the cause of malfunction or failure is otherwise covered by our warranty or not. In any event, Nieco's liability shall be limited to replacement of the equipment or return of the equipment and refund of the original purchase price.

The Nieco warranty does not cover the following:

1. Ordinary wear and tear, deterioration or damage, except elements that are warranted against any failure.
2. Defects in parts or performance caused by improper cleaning, maintenance or adjustment.
3. Adjustments are not covered by warranty except when a part needing such is replaced under warranty by a Nieco servicer.
4. Misuse or improper cleaning or assembly of the toaster and its components.
5. External causes of defective performance. This includes electrical supply and hookup parts.
6. Machines that have been improperly repaired by non-Nieco servicers.
7. Machines with parts installed which Nieco does not approve or supply. Approved parts are available from your Nieco Service Center or otherwise authorized Nieco parts seller. No other parts have been tested or approved by Nieco.
8. Damages caused in shipment.
9. Damage from moisture into electrical components.
10. Damage from tampering with or removal of any safety device.

Warranty items, labor or parts, are available from your Nieco Service provider. Nieco parts may also be purchased directly from Nieco's United States or Canada master parts distributors.

NIECO DUAL VELOCITY™ TOASTER WARRANTY

Labor warranty is subject to these limitations:

- Labor warranty work is to be performed during regular working hours. Off-hour labor may be subject to additional charge by the servicer.
- One-hour travel in each direction to the restaurant from the servicer's place of business is included. Restaurants in more distant or remote locations may be charged additional travel time or overnight accommodation, if necessary.

Your Nieco Service provider will make warranty decisions. Nieco has provided our servicers with guidelines for warranty work and standards for repair time. If your Nieco servicer rejects your warranty claim, you are required to pay the servicer even though you dispute the charge. To dispute any warranty decision, first contact the Service provider principals. If you are not satisfied, contact Nieco Service Department or any Nieco Customer Service administrator. Nieco will immediately investigate your claim and make a warranty decision. If you have paid your servicer and your claim is honored, your money will be refunded. You are responsible for paying the servicer when due, however, regardless of the status of any claim.

Contact: service@nieco.com

If you are supplied warranty parts without warranty labor, Nieco or your warranty parts supplier may require the parts to be returned to the factory as a condition of receiving the warranty parts. This is particularly true of high value important components as motors and controls, or any parts showing a pattern of failure. If required, Nieco will pay the return freight cost and give instructions via your servicer on how to return the parts.

If required, Nieco will pay the return freight cost and give instructions via your servicer on how to return the parts.

Warranty parts not installed by the servicer will be shipped by your servicer or directly from Parts Town. If you require more immediate shipment, your service parts supplier may charge additional for expedited freight service.

If you have qualified maintenance employees or wish to use a qualified non-Nieco agency for warranty labor service otherwise covered under this Nieco warranty, you or your servicer may apply to Nieco for certification as an alternate Nieco servicer. Such servicer shall be solely responsible to the using customer for all actions and liabilities.

If Nieco qualifies such servicer, Nieco will pay scheduled warranty allowances to the servicer for warranty work performed. This payment will not include any travel time. Nieco will provide this schedule and limitations when the servicer is qualified and accepted.

Warranty Parts Schedules

These schedules list common parts that are covered as of November 1, 2021. Nieco may from time to time add, alter or delete specific parts as the machine specification or parts availability changes. A current schedule can be obtained from Nieco. Any other warranty work is on an as required basis and will be covered by Nieco servicers.

This warranty is valid for North America and most other countries. Mandated warranties in some countries may vary due to specific warranty laws, requirements or commercial practices or customs in these various countries. Check with the country Nieco Servicer for variations from this basic Nieco warranty.

The parts schedules listed are those common parts that are warranted by Nieco. If the part requires service replacement, your Nieco Servicer will do it, within the terms of this warranty. If your restaurant requires additional service or travel time, your Servicer will make an extra charge for those services or distances.

P/N	Description	Standard Repair Time
15329	Solid State Relay, 50A	30 min.
29200	High Pressure Blower	30 min.
16034	Transformer, 100-115/230V Input, 24V Output	30 min.
21094	Brushless Motor	30 min.
30228	Paired Element	30 min.

SPECIFICATIONS

Construction

Type 430 Stainless Steel

Electric Power

208 Volts, 23A Single phase

Overall Dimensions

37" H x 30" L x 27" W

Weight

112 Lbs.

Load Slot Height

1.9"

Revision History:

DATE	NOTES	REV
04.15.2022	Released	A



7950 Cameron Drive
Windsor, CA 95492

Phone: 707.284.7100
Fax: 707.284.7430

service@nieco.com