



EASY CHEESE BLOCKER™ N55350A OPERATING AND MAINTENANCE INSTRUCTIONS

IMPORTANT

1. To get the best operation and life from your machine, please read and comply with these instructions.
2. Clean machine thoroughly before and after each use using cleaning instructions below.
3. Minimize the use of alkaline cleaners as they may cause pitting and dulling of the finish.

OPERATION

1. This EASY CHEESE BLOCKER will cut up to 40 pound blocks of cheese down to size with speed and ease.
2. Place the blocker on a good firm work surface. Be sure the TUBE CAP will contact the work surface to avoid wire breakage.
3. Remove wrapping from the cheese.
4. Lift CUTTING BOW and place the cheese on the BASE so the intended cut is over the slot. Gently, but firmly, pull the CUTTING BOW downward to make the cut.

NOTE: The notches on the top of the FRONT PLATE and the raised dots on the BASE indicate ½" increments from the line of cut. They will aid in aligning the cheese block and in positioning the Cheese Blocker™ for uniform slices.

5. Remove the portion cut-off, raise the CUTTING BOW and position the cheese for the next cut.
6. If unit fails to work properly when first operated call NEMCO customer service at 1-800-782-6761.

CLEANING

NOTE: Proper maintenance plays an important part in the life span and functioning of the unit

1. The EASY CHEESE BLOCKER™ is dishwasher safe or can be placed in a sink for conventional washing methods.
2. The FRONT PLATE can be readily removed for cleaning by removing the THUMB SCREWS.
3. The machine can be totally disassembled with small hand tools.

TO REPLACE CUTTING WIRE

1. Remove THREAD CAPS and loosen WING NUTS.
2. Place the new CUTTING WIRE loops on the EYEBOLT and L-SCREW.
3. Tighten the WING NUT on the L-SCREWS until the L-SCREW is secure against the CUTTING BOW. The "L" must be in the vertical position.
4. Replace the THREAD CAP.
5. Tighten the WING NUT on the EYEBOLT to bring the eye secure against the CUTTING BOW. Replace THREAD CAP.

NOTE: Avoid twisting the wire when tightening the WING NUTS.

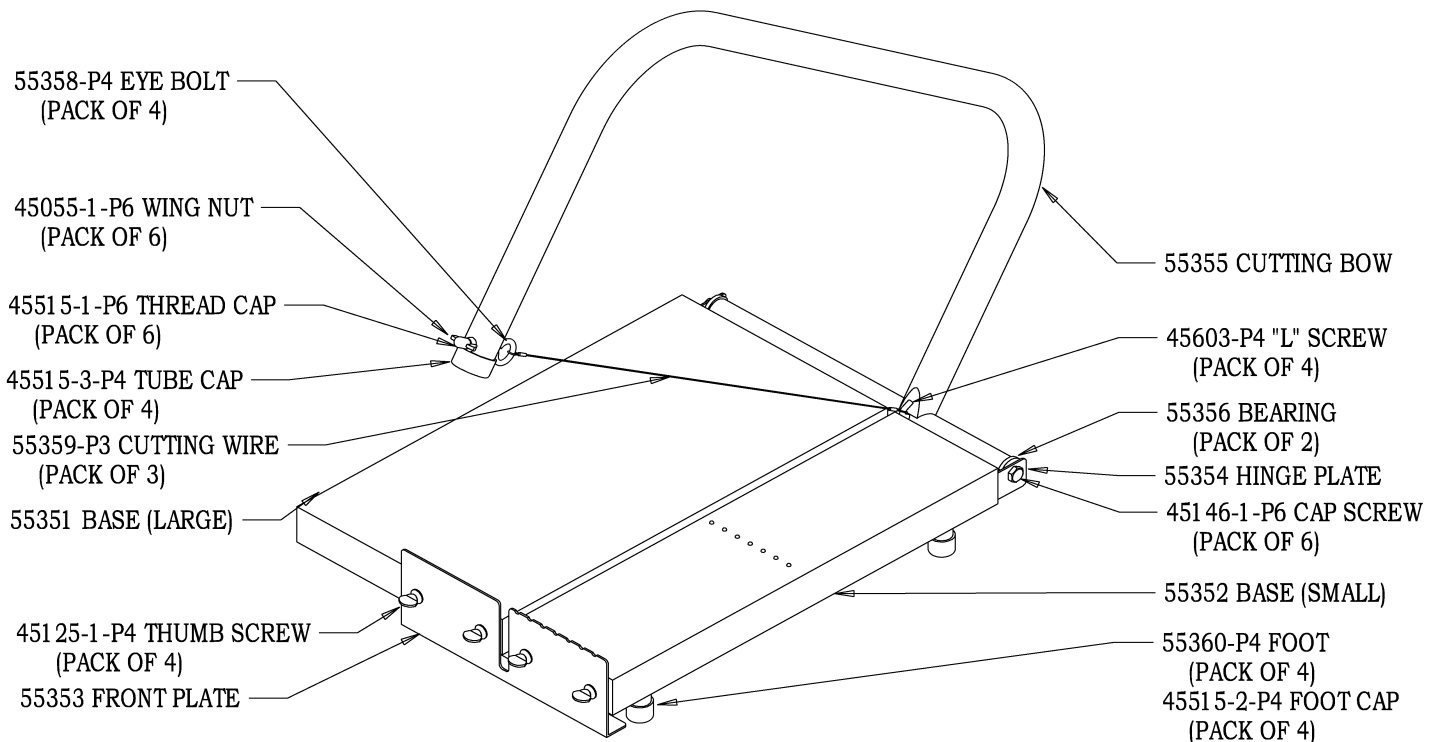

NEMCO FOOD EQUIPMENT

301 Meuse Argonne, Hicksville, OH 43526

Phone: (419) 542 7751

Fax: (419) 542-6690

Toll Free: 1-800-782-6761

46019

www.nemcofoodequip.com

4-12-10