

SPARE AND REPLACEABLE PARTS

The only ShrimpPro user-replaceable parts are those in the shrimp cutting area. While the Blade is made from long-lasting, hardened stainless steel, it will begin to lose its effectiveness in time and start tearing rather than cutting shrimp. Do not attempt to sharpen as Blade will lose its hardness. Replacement Blades may be ordered from The NEMCO factory. (See phone, fax and address below.) Having at least one spare on hand, stored in a secure and accessible place, will avoid downtime.

Generally, the other components in the cutting area will not require replacement. However, it is possible for the Feeder Discs to eventually become too smooth to reliably grasp all sizes of shrimp. Replacements may be ordered. We can also provide a new part to replace any component that is lost or damaged.

PRODUCT SERVICE

The ShrimpPro is inherently very reliable and, because of its rugged construction, should require little or no service throughout its lifetime. However, if service is ever needed, it must be performed at the factory or by an authorized service center. Any attempt to effect repair without permission or guidance from the manufacturer may invalidate the warranty and could be dangerous.

Nemco has a staffed service department and we believe prompt service is extremely important to our customers. Therefore, we request all product service inquiries be handled in the following manner:

- (1) The end user should call Nemco Customer Service with the company name, address, phone number, model number, serial number (if applicable), Nemco Sales Order number or Dealer Purchase Order

number and the nature of the problem (the "Claim Information").

- (2) The Nemco Customer Service Department will decide on the most appropriate course of action. If Nemco determines that it must inspect a product, the following procedure will be followed.

The end user will obtain a Return Goods Authorization number from Nemco Customer Service to return the product to Nemco for inspection. Please be sure to use this number on the box and on paperwork sent with the unit. Return the unit to Nemco. The Nemco Service Department will determine if the problem is covered by the foregoing warranty. If so, Nemco will repair the unit and return it to the end user. If the unit is determined not to be covered by the foregoing warranty, the dealer will be contacted to determine the next course of action.

ShrimpPro PRODUCT WARRANTY REGISTRATION

To validate your warranty, it is important that you fill in and return the Warranty Certificate promptly. When completed mail to:

NEMCO Food Equipment, Ltd.
301 Meuse Argonne
Hicksville, OH 43526

ShrimpPro SPECIFICATIONS

Manufactured by NEMCO Food Equipment, Ltd.
Model No.: 55925
Power: 120 V.A.C., 60 Hz, 1 Amp
240 V.A.C., 50Hz, 0.5 Amp
Shipping Weight: 18 lbs.
U.S. and Foreign Pats.

PRODUCT WARRANTY

Except as otherwise provided below, Nemco Food Equipment, Ltd. ("Nemco") warrants, to the original user, its electrical food preparation products (other than blades and light bulbs) to be free of electrical and mechanical defects in material and workmanship under "normal use" (defined below) for the shorter of the following periods: (a) one (1) year from the date placed in service by the original user, or (b) 18 months from the date of shipment from its factory. In addition, Nemco warrants its non-electrical food preparation products (other than blades) to be free of mechanical defects in material and workmanship under normal use for two (2) years from the date placed in service by the original user. The warranty provided for herein shall be limited to parts and labor. Any determination that a product is defective or covered by this warranty, shall be made by Nemco, in its sole discretion. The determination of whether to repair or replace a defective, covered product, or to refund the purchase price for the product, will be at Nemco's sole discretion. This warranty does not cover products used outside the United States, or damages caused by accident, misuse, negligence of any person other than Nemco, current or voltage other than stated on the appliance, fire, flood or other casualty. Any alteration to the product or unauthorized repair voids this warranty. For purposes of this warranty, the phrase, "normal use" shall mean the use of the product in connection with food in accordance with the product manual accompanying the product.

Nemco shall be responsible only for repairs or replacements of defective parts performed by Nemco's authorized service personnel. Authorized service agencies are located in principal cities throughout the continental United States, Alaska and Hawaii.

THE FOREGOING WARRANTY IS EXCLUSIVE AND IN LIEU OF ALL OTHER WARRANTIES, EXPRESS OR IMPLIED. NEMCO EXPRESSLY DISCLAIMS ANY IMPLIED WARRANTY THAT ANY OF ITS PRODUCTS IS MERCHANTABLE, FIT FOR A PARTICULAR PURPOSE, OR DOES NOT INFRINGE ON THE RIGHTS OF ANY THIRD PARTY. THE FOREGOING WARRANTY SHALL BE NEMCO'S SOLE AND EXCLUSIVE OBLIGATION. ANY PERSON'S (BUYER, USER OR OTHERWISE) EXCLUSIVE REMEDY AGAINST NEMCO, AND NEMCO'S SOLE OBLIGATION, FOR ANY AND ALL CLAIMS, WHETHER FOR BREACH OF CONTRACT, WARRANTY, TORT (INCLUDING WITHOUT LIMITATION NEGLIGENCE), OR OTHERWISE, SHALL BE LIMITED TO NEMCO REPAIRING OR REPLACING THE PRODUCT, OR, AT NEMCO'S OPTION, REFUNDING THE PURCHASE PRICE THEREFOR. IN NO EVENT SHALL NEMCO HAVE ANY LIABILITY FOR DAMAGES IN AN AMOUNT EXCEEDING THE PURCHASE PRICE OF THE PRODUCT, NOR SHALL NEMCO HAVE ANY LIABILITY FOR INCIDENTAL, SPECIAL OR CONSEQUENTIAL DAMAGES. Any person desiring to make any claim against Nemco must do so within six (6) months after expiration of the applicable warranty period, or such claim shall be forever barred.



NEMCO Food Equipment, Ltd.
301 Meuse Argonne
Hicksville, Ohio 43526
Phone (419) 542-7751
Fax (419) 542-6690
Toll Free (800) 782-6761
www.nemcofoodequip.com

ShrimpPro® Power Shrimp Cutter and Deveiner™

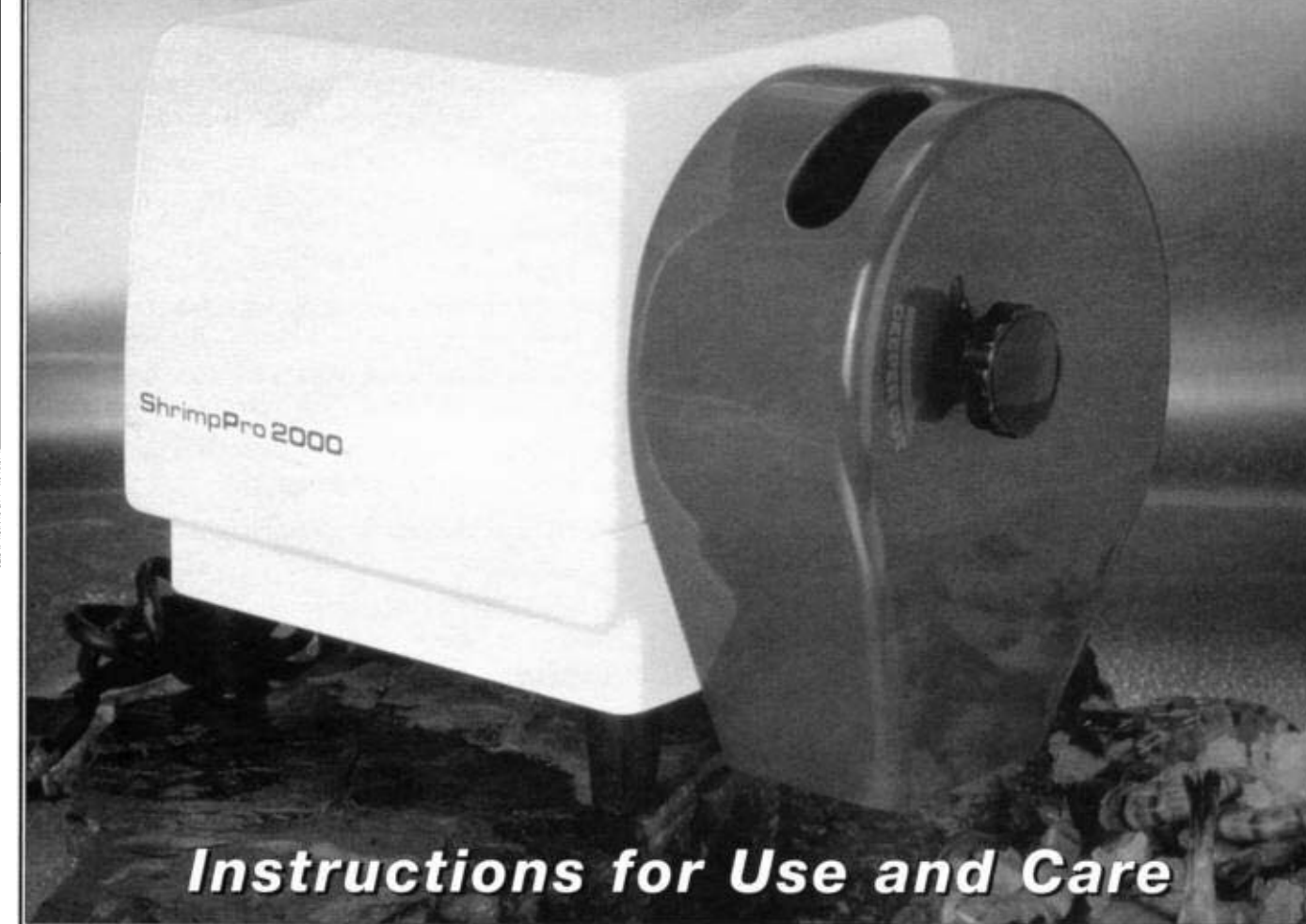

Instructions for Use and Care

Congratulations! You have just acquired the World's finest electrically powered shrimp deveiner. The ShrimpPro is a professionally engineered tool, designed for the rigors of commercial and institutional use. It turns a difficult, time-consuming and sometimes hazardous task, requiring skill, into one that is easier, faster and safer. Using the ShrimpPro, shrimp preparation can be performed by someone with little or no previous experience with a minimum of training.

The shrimp are simply dropped into the ShrimpPro's feed opening where they are grabbed by a pair of feeder discs. These discs guide the shrimp over the rotating cutter which cuts through the shell, cutting out the vein as the shrimp passes. A depth of cut adjustment allows the ShrimpPro to devein, butterfly or split the shrimp in half and the machine can be set

up to process shrimp ranging in size from 70/80 count to U/8.

Please read this instruction booklet in its entirety and keep it handy for future reference. Do not attempt to use the machine until you've finished reading and fully understand these instructions. Also, read the product warranty statement and complete the Product Warranty/Registration Certificate. Mail the completed Certificate to the manufacturer.

ATENCIÓN

Para evitar el riesgo de daños personales, es muy importante que entienda completamente estas instrucciones. Si tiene alguna dificultad siguiendo el texto en inglés, encuentre a alguien que sepa inglés y español perfectamente, para que le ayude a traducirlo.

IMPORTANT SAFEGUARDS

- **READ ALL INSTRUCTIONS**
- **NEVER** immerse the power unit in water or other liquid. Severe electrical shock can result.
- **CLOSELY SUPERVISE** nearby children when using ShrimpPro.
- **DO NOT** operate the ShrimpPro outdoors.
- **DO NOT** attempt to operate the ShrimpPro if the unit has been dropped or if power cord or power plug have been damaged. Return it for repair. (See SERVICE.) There are no user serviceable parts.
- **DO NOT** operate when wearing loose clothing or accessories (bracelet, neck chain, necktie, scarf, etc.). These could be caught by the rotating Discs and cause injury. Loose hair should be pulled back and secured.
- **MAKE SURE** that the power cord is unplugged before removing Cutting Guard.
- **AVOID** touching the moving Discs. They could grab your fingers and draw them into the cutter.
- **THE SHRIMPPRO** is equipped with a power cord with a three-blade plug. Plug this **ONLY** into a matching 120 volt A.C. three-blade outlet. **DO NOT** cut off the third blade or attempt to use with a two-blade extension cord. If you are too far from the outlet, use a three-wire extension cord of adequate power rating (see specifications), obtainable at almost any hardware store.
- **UNPLUG** the machine when not in use, before attempting to clean, when changing Blades or when making any adjustments to the Discs. Pull only on the plug, never on the cord.
- **MAKE SURE** that the power switch is in the 'OFF' position before plugging-in or unplugging the power cord.
- **DO NOT** attempt to use with unauthorized attachments or for any application other than that for which the unit was designed. Such use could create a hazardous situation or cause personal injury to the user.
- **DO NOT** operate on or near hot surfaces or appliances used for cooking.
- **DO NOT** let power cord hang over edge of table or counter.
- **WHEN NOT IN USE**, store the unit in a safe place where it will not be a hazard to passers-by.
- **ALWAYS** store with Cutting Guard securely attached so that the blade is covered for safety.
- **NEVER** attempt to lift ShrimpPro by its Cutting Guard. Always lift from under the base.

SAVE THESE INSTRUCTIONS

INSTRUCTIONS FOR USE & CARE

UNPACKING

When you open the shipping container, you will find that the ShrimpPro is fully assembled and ready to cut medium-sized shrimp (16/20 to 36/40). In the carton, you will also find two Depth Cut Rollers, differing in width. If you wish to cut small or large shrimp, you must replace the already mounted medium Roller (Item number 4 in the exploded view drawing of Page 7) with the appropriate alternate (the wider Roller for larger shrimp and the narrow one for small shrimp). The procedure for replacement is given on page 3.

Two 9/16" open end wrenches, used for Cutting Blade replacement or cleaning, and a bottle

of lubricant with a dropper top are also packed with the ShrimpPro. This is a food-grade lubricant which is approved for incidental contact with food.

Examine the ShrimpPro for possible shipping damage. Remove the Cutting Guard and inspect cutting area components (see exploded view drawing). The Cutting Guard (Item number 2) may be removed by first unscrewing the Depth Adjustment Knob (Item 1) and then pulling the Guard away from and off of the machine. When removing the Guard, make sure that the Adjustment Knob Washer (Item 3) remains on the Guard (Item 2). If any damage is noted, immediately notify both the shipping company and the manufacturer.

EXPLODED VIEW, LIST OF PARTS

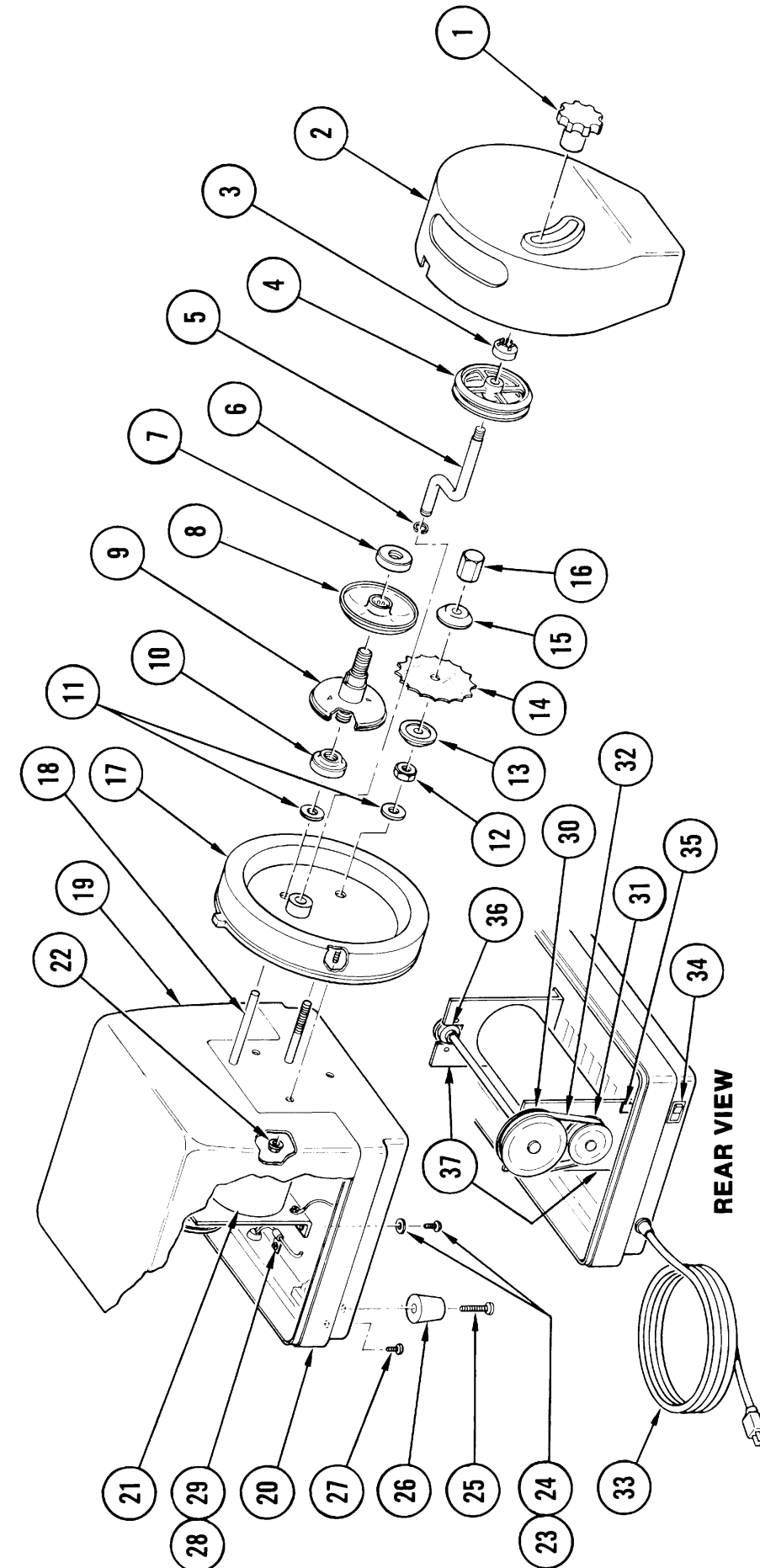

Parts List

1	47137	Depth Adjustment Knob
2	55981	Cutting Guard
3	45184	Cutting Guard Washer
4	46959	Depth Cut Roller (Medium)
	46960	Depth Cut Roller (Large)
	46961	Depth Cut Roller (Small)
5	55970	Idle Shaft
6	46328	Retainer Spring
7	56017	Jam Nut
8	55979	Female Feeder Disc
9	55974	Male Feeder Disc
10	56016	Pipe Thread Nut
11	45409	Shaft Seal

12	45073	Hex Nut, 3/8 - 16
13	55976	Blade Support Washer
14	55977	Cutting Blade
15	55976	Blade Support Washer
16	56009	Blade Holder Nut
17	55969	Front Plate
18	55961	Feeder Disk Shaft
19	55973	Top Housing
20	55968	Bottom Housing
21	47488	Motor
22	46069	Thread Cutting Nut
23	46698	Screw, #10 - 32 x 3/8"
24	45180	Washer, #10 Lock

25	46666	Screw, #10 - 16 x 1"
26	46949	Leg
27	46665	Screw, #8 x 3/4"
28	46663	Screw, #10 x 3/8"
29	46958	Cable Clamp
30	46955	Drive Pulley (Large)
31	46956	Drive Pulley (Small)
32	46957	Drive Belt
33	47481	Cordset
34	47482	Power Switch
35	55983	Rectifier
36	46953	Bearing
37	55960	Mounting Bracket

To clean:

1. Unplug the machine and remove the Cutting Guard.
2. Remove Outer Feeder Disc, Depth Cut Roller and Shaft, Cutting Blade, Blade Support Washers and Inner Feeder Disc.

CAUTION: CUTTING BLADE IS SHARP. USE EDGE CUT RESISTANT GLOVES WHEN CLEANING BLADE!

3. Use hot, soapy water and a sponge or brush to scrub all debris from the Discs, Shafts, Roller, Cutting Blade, and Cutting Guard. These components are all dishwasher-safe.
4. Treat all components that come into contact with food with an anti-bacterial solution.
5. Wipe down the cutting area of the unit with hot soapy water, using a sponge or towel. Take care that water does not enter the motor housing through the output shaft holes. Treat the Shafts and cutting area with an anti-bacterial solution.
6. With the sponge or wet towel, wipe down the unit's exterior. DO NOT allow water to enter the case through the air vents.
7. Dry the unit with a clean towel. Reassemble.

Note: ALWAYS STORE SHRIMPPRO WITH THE CUTTING GUARD ON TO PROTECT WORKERS FROM POSSIBLE BLADE CUTS.

TROUBLESHOOTING

Problem:

Motor doesn't run when power switch is turned 'ON'.

Action:

1. Check to see that unit is plugged-in.
2. Make sure that electrical outlet is live by trying another appliance or lamp in the same outlet. If unit still won't work, return it to the factory for repair. (See Service, below.)

Problem:

Motor runs but Feeder Discs do not turn.

Action:

1. Check to see that both Inner and Outer Feeder Disc Nuts have been tightened.

2. A problem may exist in the motor drive section — the drive belt may have broken or come off of the drive pulley or some other internal damage has resulted, either from the unit being dropped or being mishandled during shipping. Belt can be replaced by user ONLY with factory guidance. If problem is not the belt, unit must be returned to factory for repair. (see Service, below.)

Problem:

Shrimp is not cut down on center and vein is not effectively removed.

Action:

The Cutting Blade is not centered between Feeder Discs. Refer to PRE-OPERATING CHECKS AND ADJUSTMENTS Section for instructions for centering Discs.

Problem:

Blade is centered but vein is not effectively removed.

Action:

1. Are shrimp cut deep enough? If not, adjust with Depth Adjustment Knob.
2. Shrimp must be thawed and firm. If not fully thawed, finish in stream of cold running tap water. If not firm, try putting shrimp in pan with ice covering for approximately 10 minutes.
3. Blade may be caked with shrimp debris. Clean off all waste material from both sides of Blade with warm, wet sponge.

UNPLUG MACHINE BEFORE REMOVING CUTTING GUARD! USE CUT RESISTANT GLOVES WHEN CLEANING BLADE!

Problem:

Feeder Discs not effectively grabbing shrimp; may spin several seconds before picking up shrimp.

Action:

1. Inspect Discs. They may be coated with shrimp debris, causing them to be slick. Remove and clean.
2. Discs may be too close together for size of shrimp. Check and reset as necessary. See instructions under 'SETTING UP FOR DIFFERENT SIZE SHRIMP'.
3. If problem continues after steps above, Discs have worn smooth. Order replacements from dealer or manufacturer.

PRE-OPERATING CHECKS AND ADJUSTMENTS

Before replacing the Cutting Guard, perform the following checks:

Note: These steps presume that you will be processing medium-sized shrimp. If you will be working small or large shrimp, the Depth Cut Roller must be changed and the Feeder Discs will need readjustment. The steps needed to do each of these are covered later in this booklet.

CAUTION: USE CARE WHEN WORKING NEAR THE EXPOSED BLADE. IT IS SHARP AND CAN CUT FINGERS, USE CUT PROTECTIVE GLOVES!

1. Cutting Blade

Make sure that the Round Cutting Blade is secure on its shaft and cannot slip. Hold the Inner Blade Nut (closest to the motor - Item 12) with one of the included wrenches. With the other wrench, turn the Outer Cap Nut (Item 16) clockwise until it is tight (See Figure A). Do not overtighten.

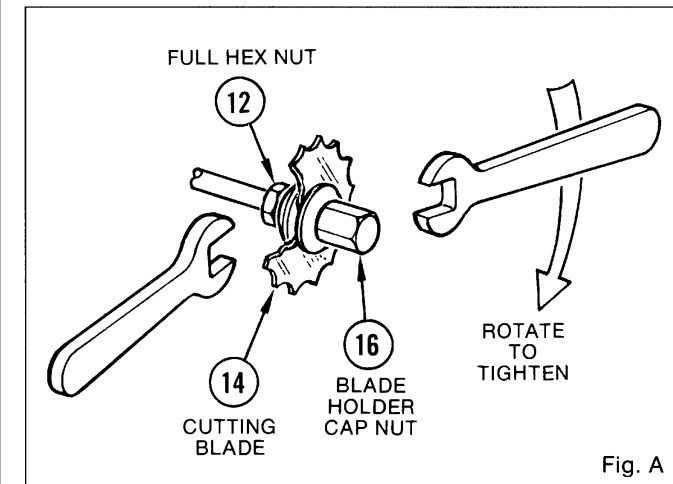

2. Depth Cut Roller

The Depth Cut Roller should be centered between the two Feeder Discs (See Figure B). If it is not correctly positioned, unscrew and remove the outer plastic Jam Nut (Item 7) from the Feeder shaft and remove the Outer Feeder Disc (Item 8). Slide the Depth Cut Roller along its shaft until it just touches the Inner Disc (Item 9). Replace the Outer Disc. When remounting this Disc, make sure that the two raised keys on the Inner Disc fit into the two keyways in the center of the Outer Disc that are marked 'M' (for medium sized shrimp). It may be necessary to lift the Depth Cut Roller in order to mate the Discs. Replace the outer Jam Nut and screw down until finger tight.

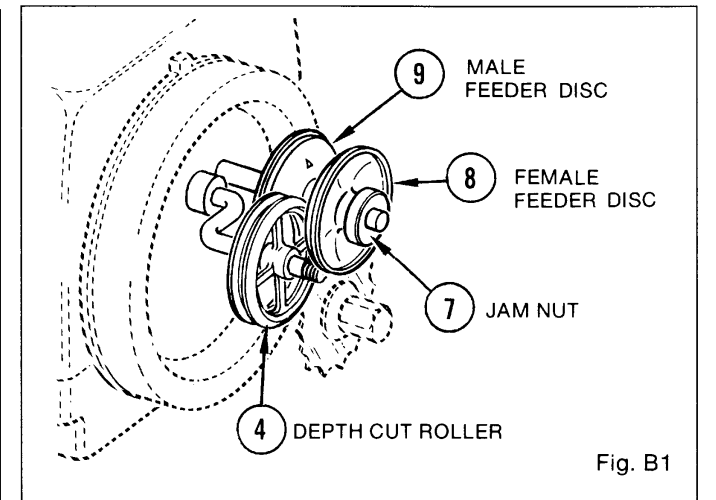

Fig. B1

3. Feeder Disc Assembly Positioning

Look down over the Feeder Discs. Make sure that the Cutting Blade is centered between the two Discs and that the groove in the Depth Cut Roller is centered over the Blade. If it is incorrectly positioned, unscrew the Feeder Shaft inner plastic nut (Item 10) by hand until the entire Feeder Disc assembly will slide on its shaft. The nut is unscrewed by turning it clockwise. See Figure C. Align the Disc Assembly so that the blade is properly centered and hand tighten the plastic nut.

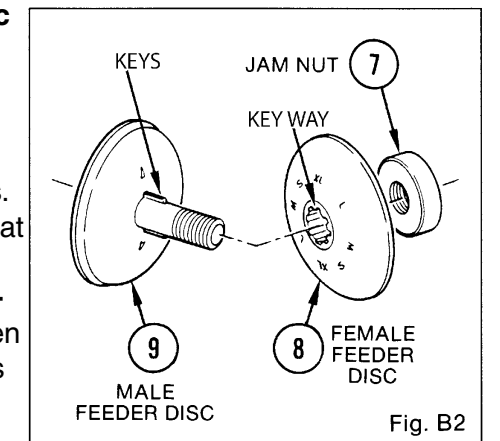

Fig. B2

4. Lubrication

Remove the cap from the dropper tip of the food lubricant bottle. Puncture the top of the dropper tip

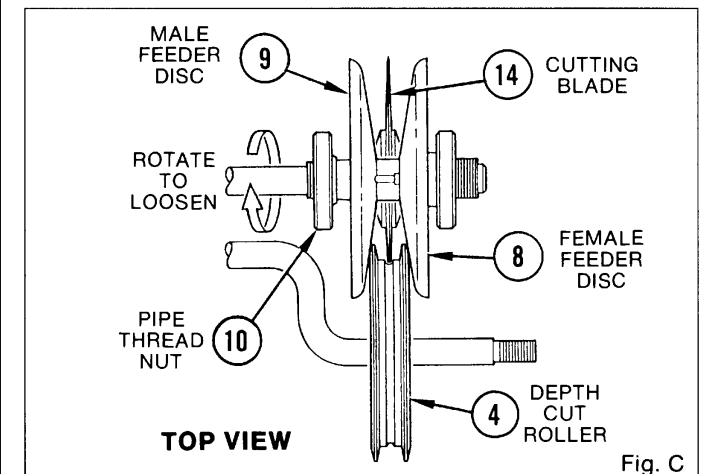

Fig. C

with a pin or small nail. Place several drops of lubricant on the Depth Adjustment Shaft on both sides of the Roller at its center hole. Lift the bent Roller Shaft and slide the Roller back and forth on it, over the lubricant, until lubricant is worked under the Roller. To ensure smooth and quiet operation, the Roller should be lubricated in this manner before each use.

5. Cutting Guard Replacement

Make sure that the power switch is in the 'OFF' position before proceeding. Make sure that the notch in the top of the Cutting Guard mates with the projection at the top of the front plate and that the Guard snaps into place on both sides. The threaded end of the Depth Adjusting Shaft fits through the plastic washer in the open arc in the front of the Guard. Replace the Adjusting Knob.

PICKING A WORK LOCATION

Choose a work location with adequate space so that you can work freely, that is well lighted, and is close to a standard 120 volt A.C. (240 volt for export model) three blade wall outlet (the line cord is about six feet long). Arrange to drape the line cord (and the extension cord, if one is used) where it will not interfere with your working freedom of movement and where it will not trip passersby.

The ShrimpPro should be placed on a flat, non-porous surface with the exit chute over the counter edge above a sink or catch tray. DO NOT select a location which can be flooded with water. The user must always work on the right side of the machine with the Feed Slot in the Cutting Guard facing him (Figure D).

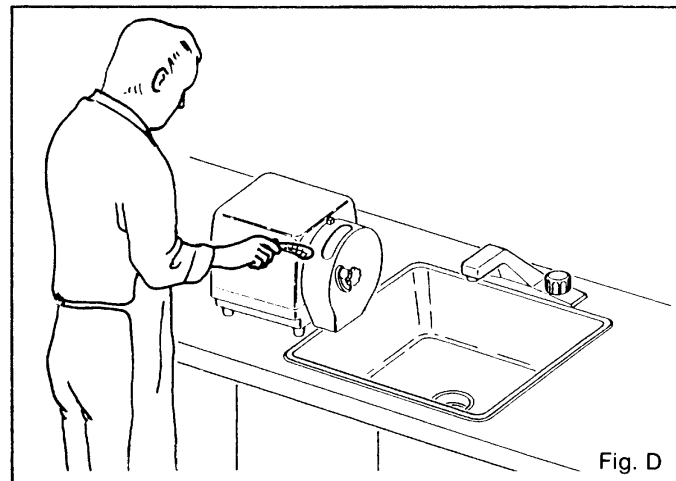

Fig. D

CUTTING AND DEVEINING SHRIMP

To be cleanly cut, shrimp must be raw, fully thawed and firm. The cutting procedure is as follows:

1. After making sure that power switch is in the 'OFF' position, plug the line cord into the wall outlet.
2. Place a container, tray or 1/2 size steam table pan containing thawed, uncooked shrimp on top of the machine.
3. Loosen Depth Adjustment Knob and slide it to the shallowest cut position (top of arc, away from 'Deeper Cut' arrow as shown in Figure E.) Tighten Knob.

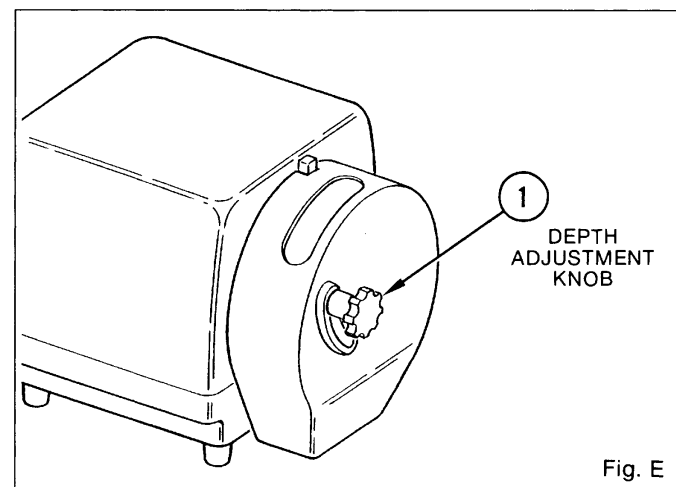

Fig. E

4. Turn the ShrimpPro 'ON'.
5. Pick up on shrimp at the tail end. Turn it so the back of the shrimp is away from you and lower it into the Feeder opening on the top of the Cutting Guard (see Figure F). The shrimp should be inserted so that it falls between the Feeder Discs and the Depth Cut Roller. The cut shrimp will be deposited in your sink or catch tray.

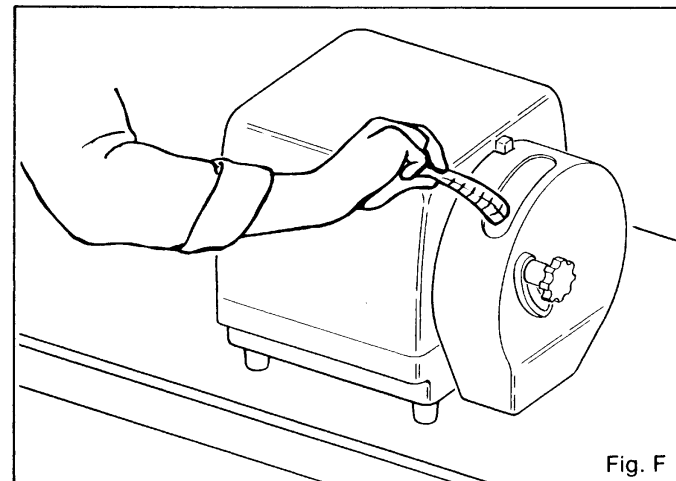

Fig. F

WARNING: NEVER, UNDER ANY CIRCUMSTANCES, ALLOW YOUR FINGERS TO ENTER THE FEEDER SLOT, A FINGER CAN BE DRAWN INTO THE MACHINE BY THE FEEDER DISCS AND BE SEVERELY INJURED.

Also, do not allow foreign objects to enter the slot. They could cause the ShrimpPro to jam and create serious damage. Should shrimp not feed properly, turn the machine off before attempting to correct the problem.

6. Inspect the cut shrimp. If greater depth of cut is desired, loosen the Depth Cut Knob and slide it down to a deeper cut position, then tighten the Knob.
7. Pass the same cut shrimp through the machine again and again, adjusting the depth of cut each time until you get the cut depth that you want. Depending upon the adjustment, shrimp can be lightly cut and deveined, butterflied or split, (knob in the full down position) or cut in any desired depth from light to full split.

SETTING UP FOR DIFFERENT SIZE SHRIMP

At delivery, the ShrimpPro has been set up for shrimp in the medium size range. If you want to cut shrimp of a different size, you must change the Depth Cut Roller and readjust the Feeder Disc spacing. ShrimpPro is shipped with two additional Rollers; one for small shrimp and one for large shrimp. The chart below shows which Roller is designed for each shrimp size group and what Feeder Disc spacing setting goes with each. Due to shrimp size and packing variations, your experience may differ somewhat. Use what works best for you.

Shrimp Size Range	Disc Setting	Roller
70/80-41/50	S	thinnest (S)
36/40-U/15	M	medium (M)
U/12-U/8	L	thickest (L)

The steps you must take to set the machine up to cut different size shrimp are similar to those covered in the earlier Section of PRE-OPERATING CHECKS AND ADJUSTMENTS. Refer back to that Section's text and illustrations if you require clarification of the instructions below.

1. Make sure that the ShrimpPro power switch is in the 'OFF' position and unplug the line cord.

NOTE: ALWAYS UNPLUG THE MACHINE BEFORE REMOVING THE CUTTING GUARD.

2. Remove the Cutting Guard by unscrewing the Depth Adjustment Knob.
 3. Unscrew and remove the Feeder Shaft outer plastic nut, then remove the Outer (female) Feeder Disc.
 4. Remove the Depth Cut Roller from the bent shaft.
 5. Select the new Depth Cut Roller from the chart above and slide it onto the Roller shaft until it just touches the Inner Feeder Disc.
 6. Remount the Outer Feeder Disc, making sure that it always engages the correct keys around the inner diameter of the Inner Disc as listed in the chart. Screw the outer plastic nut back on the shaft, making it hand tight.
 7. Loosen the inner Feeder Shaft Nut and slide the Disc assembly along the shaft until the Cutting Blade is **centered** over the groove in the selected Roller. Hand tighten the inner nut.
- A REMINDER — USE CAUTION WHEN WORKING NEAR THE CUTTING BLADE! IT IS ALWAYS BEST TO USE CUT PROTECTIVE GLOVES.**
8. Replace the Cutting Guard and Depth Adjustment Knob, making sure that Depth Shaft goes through the plastic Guide Washer in Guard arc opening. Set adjustment for shallowest cut.
 9. Check power switch. It should be in the 'OFF' position. Plug the line cord in.
 10. Turn machine on and begin to cut shrimp. Adjust for depth of cut as described earlier.

CLEANING

ShrimpPro should be thoroughly cleaned after each days use.

CAUTION: DO NOT IMMERSE THE UNIT IN WATER. THIS COULD CAUSE DAMAGE TO THE MACHINE AND CREATE THE POSSIBILITY OF OPERATOR ELECTRICAL SHOCK THE NEXT TIME IT IS USED.