

Convection Ovens

Model #s: 6220-17, 6240

USER MANUAL

6240



6220-17



CONTENTS

TECHNICAL DATA	Page. 3
INTRODUCTION	Page. 7
Identifying the danger or warning signals	
Purpose of the product	
INSTALLATION	Page. 7
Installation requirements	
Transport	
Unpacking	
Installing the feet	
Placement	
Electrical connection	
Water connection	
Water drain	
Conditioning the appliance	
OPERATION INSTRUCTIONS	Page. 11
Controls	
General cooking information	
CLEANING AND MAINTENANCE	Page. 14
Outer stainless steel surfaces	
Side supports	
Air cover	
Light bulb	
Door gasket	
Cooking chamber	
External door glass	
Internal door glass	
TROUBLESHOOTING	Page. 21
WIRING DIAGRAM	Page. 22
EXPLODED DRAWINGS AND SPARE PARTS	Page. 24
PRODUCT WARRANTY	Page. 30
PRODUCT SERVICE	Page. 30
TERMS & CONDITIONS	Page. 30

6220-17 Technical Data

CAPACITY

- (3) 18 in x 13 in / 460mm x 330mm half size pans

STANDARD EQUIPMENT

- (2) 3-level side supports, 2.92 in (74 mm) step

FUNCTIONAL FEATURES

- 200°F to 500°F temperature range
- Cooking timer up to 2 hours or run on infinite for continuous heat
- Convection cooking

CONSTRUCTION FEATURES

- Stainless steel constructed cooking chamber and shell
- Glass door to facilitate cooking and cleaning operations
- Recessed gasket to guarantee a sealed cooking chamber



INSTALLATION REQUIREMENTS

- The oven must be positioned on a level surface
- Hot surfaces must comply with the minimum distance from the oven:
 - Left Side: 19.7 in (500mm)
 - Right Side: 19.7 in (500mm)
 - Rear Panel: 19.7 in (500mm)
- Other surfaces must comply with the minimum distances from the oven:
 - Left Side: 3.94 in (100mm)
 - Right Side: 3.94 in (100mm)
 - Rear Panel: 3.94 in (100mm)

SIZE SPECIFICATIONS

Weight without packaging:	61 lbs (27.7 kg)
Height without packaging:	21.06 in (535 mm)
Width without packaging:	23.62 in (600 mm)
Depth without packaging:	27.91 in (709 mm)
Weight with packaging:	71.2 lbs (32.3 kg)
Height with packaging:	23.62 in (600mm)
Width with packaging:	25.60 in (650mm)
Depth with packaging:	29.92 in (760mm)

MAXIMUM LOAD PER PAN

3.5 lbs (1.5 kg)

OPERATION ELECTRICAL REQUIREMENTS

Voltage (V)	Amperage (A)	PH	Hz	AWG	Connection	Watts (W)	Type of Plug
120	14.5	1	60	14	L1, L2/N, G	1700	NEMA 5-15

6220-17 Overall Dimensions

Front View

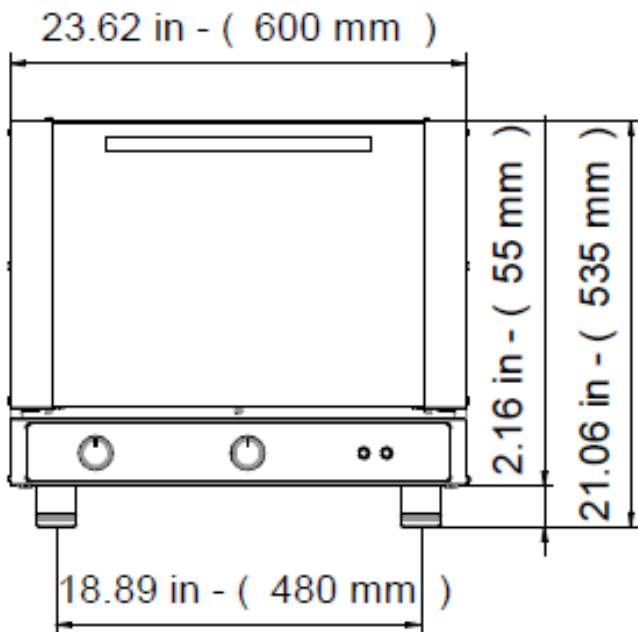

Side View

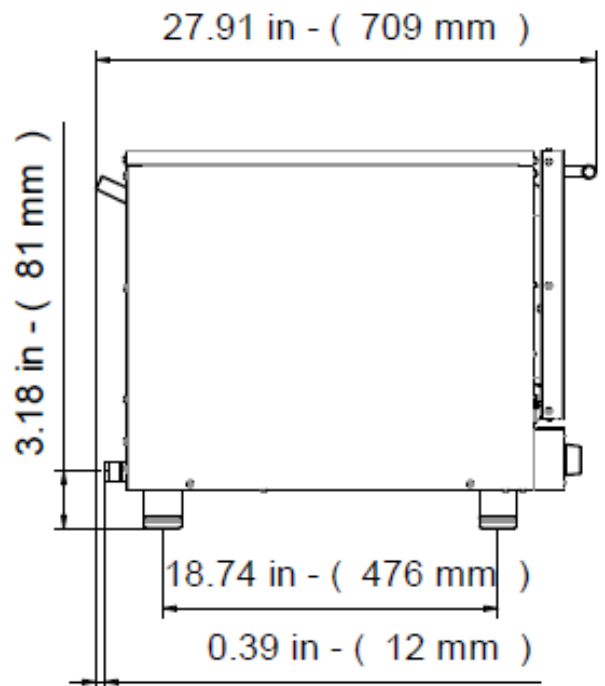

**Side View
Door Open**

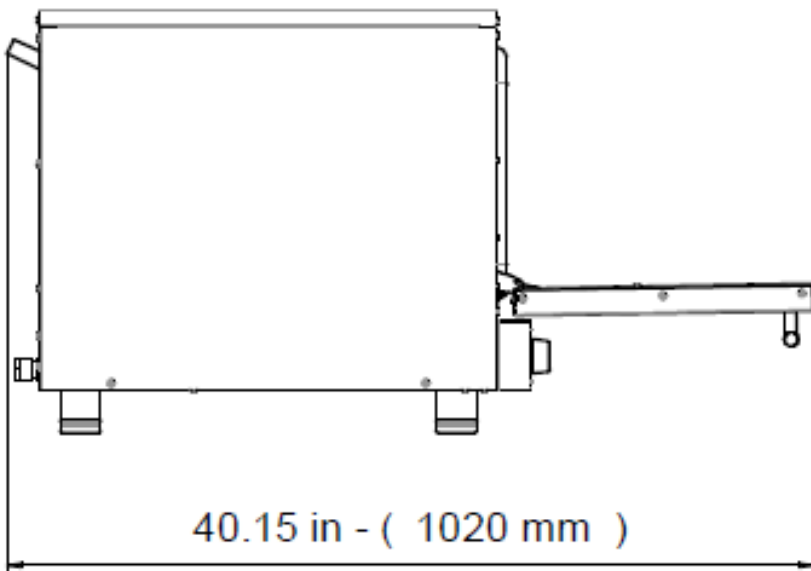

Rear View

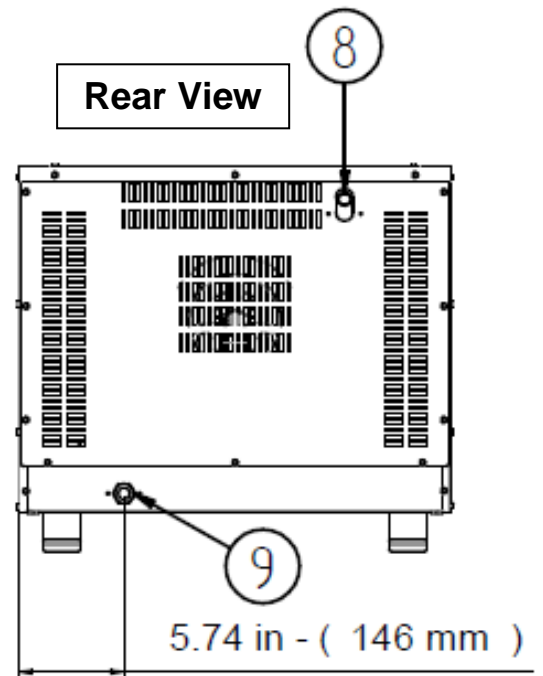

8	STEAM EXHAUST PIPE
9	POWER CORD STRAIN RELIEF

6240 Technical Data

CAPACITY

- (4) 13 in x 9 in / 330mm x 230mm quarter size pans

STANDARD EQUIPMENT

- (2) 4-level side supports, 1.00 in (25 mm) step

FUNCTIONAL FEATURES

- 200°F to 500°F temperature range
- Cooking timer up to 2 hours or run on infinite for continuous heat
- Convection cooking



CONSTRUCTION FEATURES

- Stainless steel constructed cooking chamber and shell
- Glass door to facilitate cooking and cleaning operations
- Recessed gasket to guarantee a sealed cooking chamber

INSTALLATION REQUIREMENTS

- The oven must be positioned on a level surface
- Hot surfaces must comply with the minimum distance from the oven:
 - Left Side: 19.7 in (500mm)
 - Right Side: 19.7 in (500mm)
 - Rear Panel: 19.7 in (500mm)
- Other surfaces must comply with the minimum distances from the oven:
 - Left Side: 3.94 in (100mm)
 - Right Side: 3.94 in (100mm)
 - Rear Panel: 3.94 in (100mm)

SIZE SPECIFICATIONS

Weight without packaging:	19 lbs (27.7 kg)
Height without packaging:	18.94 in (481 mm)
Width without packaging:	18.11 in (460 mm)
Depth without packaging:	20.22 in (513,6 mm)
Weight with packaging:	48.5 lbs (22 kg)
Height with packaging:	17.24 in (438mm)
Width with packaging:	20.90 in (531mm)
Depth with packaging:	23.85 in (606mm)

MAXIMUM LOAD PER PAN

3.5 lbs (1.5 kg)

OPERATION ELECTRICAL REQUIREMENTS

Voltage (V)	Amperage (A)	PH	Hz	AWG	Connection	Watts (W)	Type of Plug
120	14.5	1	60	14	L1, L2/N, G	1700	NEMA 5-15

6240 Overall Dimensions

Front View

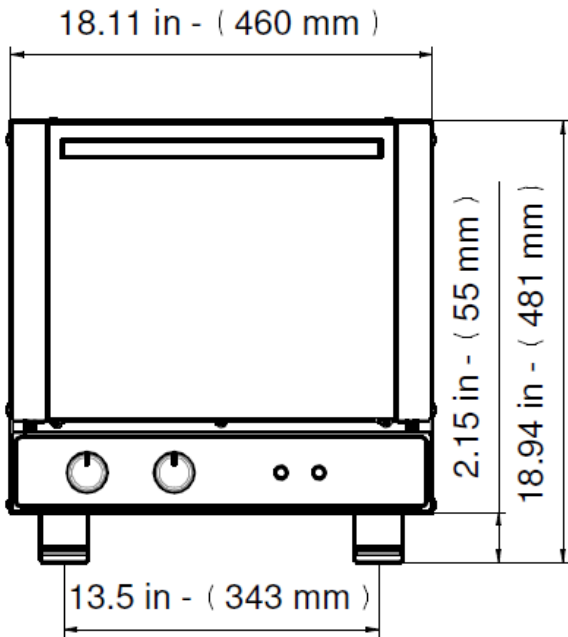

Side View

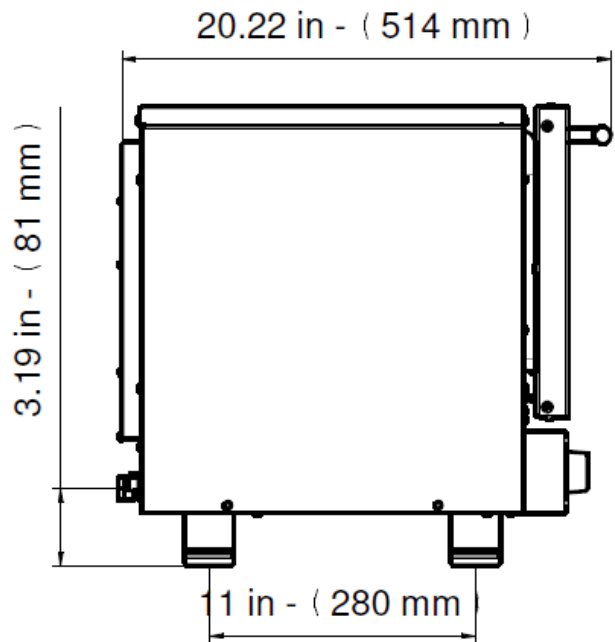

Rear View

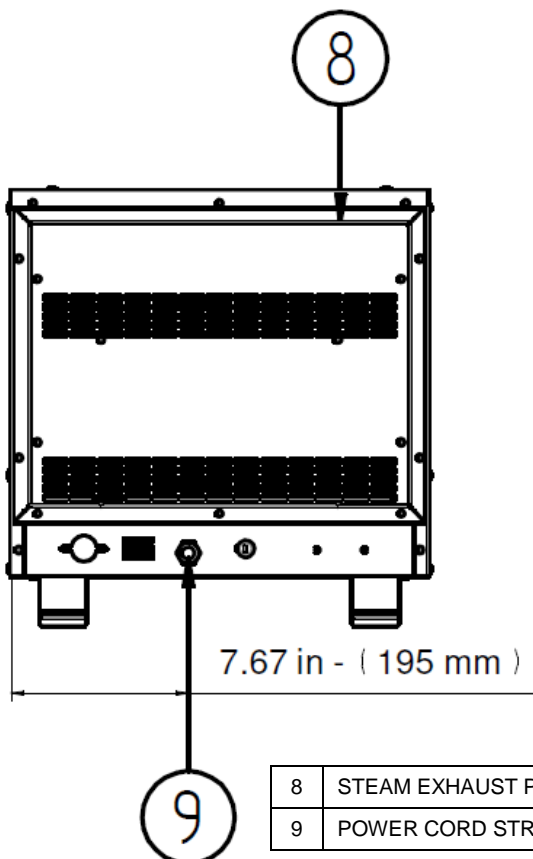

**Side View
Door Open**

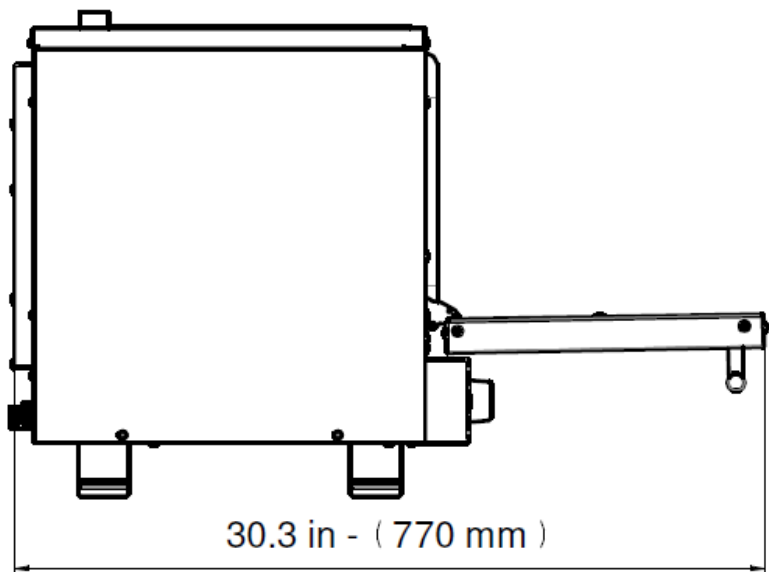

8	STEAM EXHAUST PIPE
9	POWER CORD STRAIN RELIEF

INTRODUCTION

Carefully read this user manual before using your new oven; pay special attention to the information highlighted with the **WARNING, CAUTION, and NOTES** symbols

Identifying the danger or warning signals:



WARNING

This signal indicates the presence of **danger, which may cause serious injury, death, or damage** if disregarded.



CAUTION

This signal indicates the presence of **danger, which may cause slight injury or damage** if disregarded.

NOTES

Notes aim at indicating details or recommendations regarding installation, operation, or maintenance. Notes contain important information, which is not related to possible risks.

This appliance has been specifically designed for food cooking. Any other use is considered improper.

INSTALLATION

	 CAUTION
	Risk of injury. Wear protective gloves during installation operations.

Installation requirements:

- All installation and conditioning operations must be performed by a technically skilled installer, following the manufacturer's instructions.
- Comply with the instructions contained in this user manual. The manufacturer shall not be liable for damage or harm to persons or property arising from installation errors. Nor are they responsible for any appliance breakage caused by faulty installation.



Transport

During transport the appliance must be kept in its packaging in order to protect it from any external damage.

Unpacking

- Remove the oven external packaging and make sure that the appliance has not been damaged during transport. Inform the shipping company in the event damage is detected.
- Remove any loose contents from the oven that are not intended for use during operation.
- Carefully remove the plastic film that protects stainless steel components. Remove any glue residue, which may result from removing the protective film, using a non-flammable solvent.

Installation of the feet

	 WARNING
	Risk of fire. This appliance has been designed to operate with specific feet. Do not use the appliance without installing the feet first. Using the appliance without feet may cause fire due to overheating.

If the feet are not installed on the appliance, they are inside the cooking chamber and must be screwed into the four threaded holes on the underside of the oven.

Placement

- Place the appliance on a perfectly level work surface.
- Should the appliance be installed near walls, shelves, or ceilings they must be of the non-flammable or heat-insensitive type; otherwise, they must be protected by an adequate fire retardant coating.

NOTES

The appliance is unsuitable for recessing.

The following minimum distances from heat sources must be complied with to guarantee correct ventilation of the appliance's electric component compartment:

Rear panel: 19.7 in / 500mm
Left side: 19.7 in / 500mm
Right side: 19.7 in / 500mm

And from near surfaces:

Rear panel: 3.94 in / 100mm
Left side: 3.94 in / 100mm
Right side: 3.94 in / 100mm

Do not obstruct the natural and/or forced ventilation openings on the appliance's exterior.
Do not obstruct the appliance's smoke/steam exhaust pipe.

Failure to comply with these notes WILL omit the manufacturer from any liability and will deem the warranty invalid.

Electrical Connection

NOTES

- Before making the connections, make sure that the voltage and frequency of the power supply system match the specifications of the "technical data" plate affixed to the appliance.
- The appliance must be connected to a suitable electrical system following the connection data located on the sides of the machine.
- If the power cord is damaged, it must be replaced by the manufacturer or a qualified service technician.
- If the oven is placed on a wheeled table, the connection conduit must be flexible. The table wheels must be locked.

Appliances supplied with power cord already fitted:

Make sure that a suitable power cord and plug have been connected to the oven.

Appliances supplied without power cord:

NOTE Any electric connection must be made by qualified service technician.

Remove the appliance's rear/side panel (depending on the model) to access the terminal block.

Apply the conduit and allow enough wire to pass through to reach the terminal block.

Connect the **hot legs** to terminals "**L1**" & "**L2**" of the terminal board and the **ground** to the terminal with the following symbol . Replace the appliance's rear/side panel once the operation is complete.

NOTES

- The electrical system must be fitted with a pole circuit breaker with rated breaking current equal to 150% of the current consumed by the appliance.
- The circuit breaker must be installed near the appliance, but not behind it, and the operator must be able to access it any time.
- The circuit breaker must be clearly marked and easily accessible in case of fire.

Water Connection

The appliance **MUST** be hooked up to a softened water supply that meets the water specifications below. It is **necessary to use a softener, filter system, and/or reverse osmosis system** to achieve this water purity and limit the formation of lime scale inside the cooking chamber.

The water pressure must range between 14.5psi (100 kPa) and 29 psi (200 kPa).

If the pressure from the main water line exceeds 29psi (200 kpa), install a pressure reducer upstream of the appliance.

If the value is lower than 14.5 psi (100 kpa) use a pump to raise the pressure. The water temperature must not exceed 86°F (30°C).

Connection to the water mains must be performed through the ¾" threaded solenoid valve located at the rear (bottom) of the appliance, interposing a mechanical filter and a stopcock (before connecting the filter drain off a certain amount of water to flush the pipe from any dirt).

To guarantee the correct operation of the appliance, the inlet water must be suitably treated to reach the requirements below:

Without chlorine	→	Less than 0.1 ppm (mg/L)
Hardness	→	30-70 ppm
Chloride	→	Less than 30 ppm (mg/L)
pH	→	from 7.0 to 8.5
Silica	→	Less than 12 ppm (mg/L)
Total dissolved solvents (TDS)	→	50-125 ppm

Failure to reach these specifications will damage the appliance and/or its internal components.

NOTE Any damage caused by limescale or other chemicals contained in the water **ARE NOT** covered by warranty.

NOTE The equipment must be installed with adequate backflow protection to comply with applicable federal, state, and local codes.

Conditioning the Appliance

- Before the ovens first use it is recommended to run it with an empty cooking chamber for 60 minutes at a temperature of 400°F. This will reduce the unpleasant, yet normal smells that come from heating the insulation that is wrapped around the cooking chamber and the silicone used for external sealing are dissipated.
- Refer to the "Operation Instructions" section for any details on how to use the oven correctly.

OPERATION INSTRUCTIONS

Control panels

Indicating lights



Program indicating light



Heat indicating light



Automatic humidifier indicating light
(for ovens with this option)

Program indicating light

It indicates that the oven is working and that cooking time may be active.

Heat indicating light

Switches off each time the set temperature is reached in the cooking chamber. It switches on again when the thermostat is triggered to re-establish this temperature.

Automatic humidifier indicating light (for ovens with this option)

It indicates the water solenoid valve is open, hence humidity is being produced in the cooking chamber.

Switches / buttons



HUMIDIFICATION button
(For ovens with this option)
Press to intermittently create humidity

Control knobs

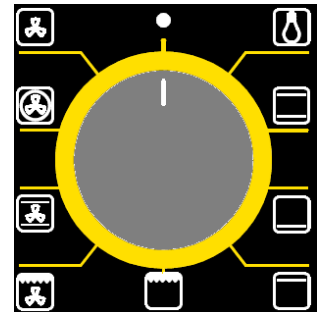
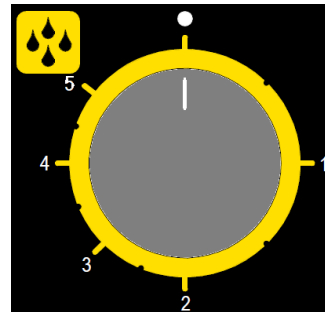
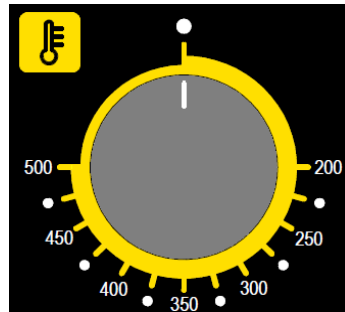
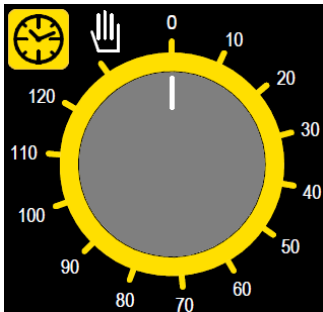



Fig. 1	Fig. 2	Fig. 3	Fig. 4
Timer Knob	Thermostat Knob	Automatic Humidifier Knob (For ovens with this option)	Function Selector Knob (For ovens with this option)

Switching on/off

Switch on the oven by turning the Timer Knob (Fig. 1) to symbol  or to the cooking time selected. It is switched off by turning the knob to “zero”.

Setting the type of cooking

Turn the function selector knob (Fig. 4) to the type of cooking desired.

Cooking time setting

Turn the Timer Knob (Fig. 1) to the cooking time selected (up to 120 minutes). End of cooking is signaled with a buzzer and the oven turning off.

Cooking temperature setting

Turn the Thermostat Knob (Fig. 2) to the desired cooking temperature.

Humidity/steam amount setting

- Turn the Automatic Humidifier Knob (Fig. 3) to the desired humidity level (from 1 to 5). 1 being minimum humidity and 5 being maximum. By turning the knob to "5" automatic humidifier control is disabled and steam is generated continuously.

General Cooking Information

Ovens fitted with humidifier button:

"Convection" cooking

Switch on the oven and turn the thermostat knob to the desired temperature.

"Convection" cooking with humidity

Switch on the oven and turn the thermostat knob to at least 300°F. When this temperature value has stabilized, press the humidification button to increase humidity in the cooking chamber.

Ovens fitted with automatic humidifier

"Convection" cooking



Switch on the oven and turn the thermostat knob to the desired temperature.

"Convection" cooking + humidity

Switch on the oven, turn the thermostat knob to the desired temperature, and turn the automatic humidifier knob to the desired humidity level.

Ovens fitted with function selector:

"Traditional" cooking

Turn the function selector knob to the symbol  and then turn the thermostat knob to the desired temperature. To achieve differentiated cooking at the top or bottom, turn the function selector knob to the symbol  for bottom heat or the symbol  for top heat.

Broiling

Turn the function selector knob to the symbol  and then the thermostat knob to the desired temperature (*"Broiling" must be performed with the oven door closed*).

Broiling with ventilation

Turn the function selector knob to the symbol  and then the thermostat knob to the desired temperature (*"Ventilated broiling must be performed with the oven door closed*).

Baking with ventilation

Turn the function selector knob to the symbol  and then the thermostat knob to the desired temperature.

Convection cooking

Turn the function selector knob to the symbol  and that of the regulation thermostat to the required temperature.

Defrosting

Turn the function selector knob to the symbol  and then the thermostat knob to “off”.

Cooking suggestions

Convection cooking

Heat is transmitted to food through pre-heated air, which is forcefully circulated in the cooking chamber. The heat reaches every part of the chamber evenly and quickly, to simultaneously cook different types of food arranged on several shelves (as long as their cooking temperature is the same), without mixing flavor and smells. Convection cooking is especially useful for rapid defrost, sterilizing bottled food, and drying fruits/vegetables.

Broiling

Almost all meats may be broiled, with the exception of some lean game and meat loafs. Meat and fish to be broiled must be slightly greased with a little oil and always placed on the rack, arranged on the closest or farthest rails depending on the type of meat in order to avoid burning it on the outside and not cooking it properly inside. It is recommended to place a tray underneath the grill to collect juice and fat drippings.

Broiling with ventilation

The thermal radiation produced by the grill is combined with forced air circulation to allow heat to gradually penetrate food without burning its surface.

CLEANING AND MAINTENANCE

	 WARNING
	Risk of electrocution. Disconnect the appliance's power supply before performing cleaning and maintenance operations.

 CAUTION
The oven is not waterproof. Do not submerge in water, spray with water jets, or steam to clean the inside or outside of the oven.

NOTES

- **Clean regularly and thoroughly.**
- **DO NOT use abrasive cleaning pads or detergents that may damage the oven. Use specified products only.**
- **At the end of every cleaning operation, make sure that any material used has been fully removed.**
- **If faults are detected, refer to the Troubleshooting guide (p. 21) and immediately perform maintenance to solve the issue. Do not wait for the component to fully break.**
- **Adapt the oven cleaning frequency based on its use.**
- **Before cleaning the appliance, allow it to cool down to room temperature.**

	 CAUTION
	Risk of injury. Wear protective gloves during maintenance and cleaning operations.

Complete Cleaning Instructions

Outer stainless steel surfaces

The outer steel surfaces must be cleaned with a cloth soaked in warm soapy water or mixed with a small amount of vinegar. Once cleaned completely the surfaces must be rinsed using a cloth soaked in only warm water and then dried with a dry soft cloth. If using other chemical products, make sure they do not contain abrasive, acid, or corrosive substances. The counter supporting the appliance and/or the floor surrounding the appliance area should also be cleaned using the same methods. Using the chemicals mentioned may corrode and deteriorate the outer stainless steel shell and cause non-reparable damage to the electrical components inside the appliance.

Side supports

- 1) Loosen the (2) hex head bolts (turn counter-clockwise) that fasten the side support to the cooking chamber.

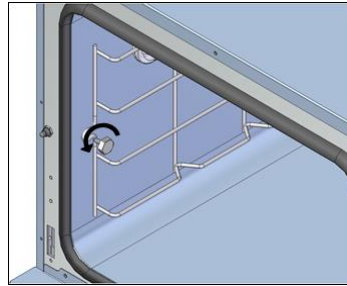

- 2) Pull the side supports towards the door to remove them from the air cover panel.
- 3) Remove the side supports from inside the oven and clean them with a mild detergent and hot water, using a soft bristle brush.
- 4) Carefully dry the side supports with a dry cloth.
- 5) Insert the side supports back into their positions on the oven air panel.

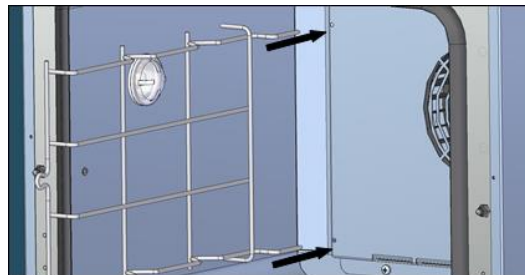

- 6) Fasten the side supports to the oven's cooking chamber using the (2) hex head bolts previously removed.

Air cover

- 1) Remove the side supports from the cooking chamber, following the "Side Supports" instructions provided.
- 2) Remove the (4) screws that fasten the air cover to the cooking chamber.

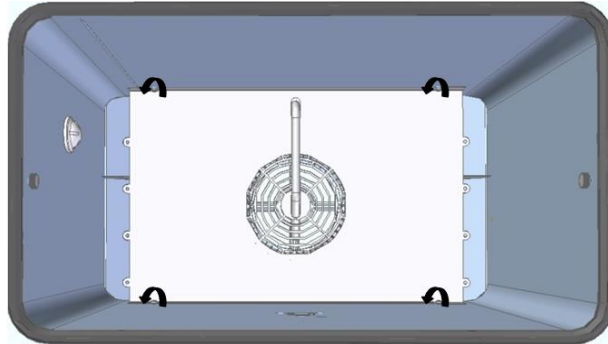

- 3) Remove the air cover from inside the oven and clean it with a mild detergent and hot water, using a soft bristle brush.
- 4) Carefully dry the air cover with a dry cloth.
- 5) Fasten the air cover to the oven's cooking chamber using (4) the screws previously removed.

Replacing the light bulb

For ovens with square light bulb covers

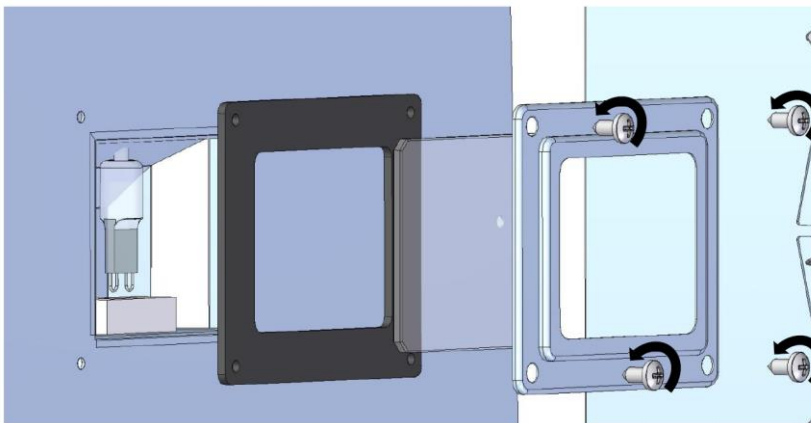

- 1) Remove the side supports from the cooking chamber, following the indications provided.
- 2) Unscrew the screws that secure the glass support and the relative seal.
- 3) Use a dry cloth to remove the light bulb from its socket and replace it with an exact match.
- 4) Reassemble the glass support and its gasket.

Door gasket - cleaning

- 1) Remove the gasket by pulling a small section until it is free from the guide. Continue pulling to fully remove the gasket. Please remember that the door gasket has a rigid profile with retainer fins (B). This profile must be pressed into the guide on the front of the cooking chamber.

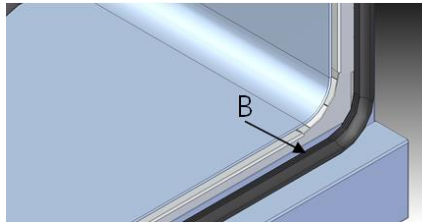

- 2) Inspect the door gasket and make sure there are no cuts or damage. If damages are found, the gasket should be replaced immediately as cooking will vary with an unsealed chamber.
- 3) If the gasket is intact, carefully wash it in a sink with soap and warm water.
- 4) After cleaning the gasket, carefully dry with a soft cloth.
- 5) Reposition the gasket inside the guide on the front of the cooking chamber, following the installation indications provided in point 1.
- 6) Press the gasket into the guide, making sure there are no gaps and the gasket is seated tightly.

Cooking chamber - cleaning

Before cleaning the cooking chamber, let it cool down to room temperature.

- 1) Remove the side supports and the air cover from the oven's cooking chamber, following the previous instructions.
- 2) Carefully clean all the parts of the cooking chamber with a mild detergent and hot water, using a soft bristle brush.
- 3) Carefully dry the oven with a dry cloth.
- 4) Remount the side supports and the air cover following the previous instructions.

External door glass cleaning

Before cleaning the outer door glass, let the door cool down completely. Clean the glass with a mild detergent and a soft cloth.

Internal door glass cleaning

(For ovens with horizontal door handle & flap door)

Before cleaning the inner door glass, let the door cool down completely.

- 1) Remove the upper and central screws on the door profiles, and partially loosen the lower screws on the door profiles.

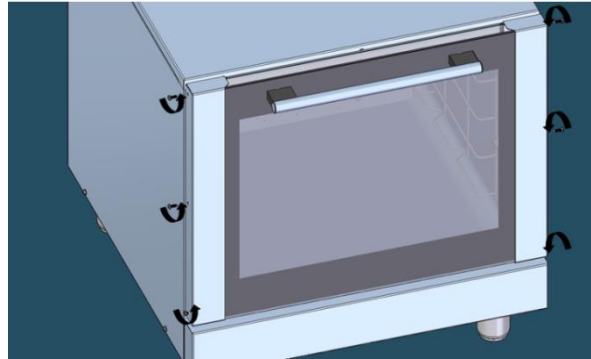

- 2) Keep the inner glass still against the oven's gasket and use the handle to open the door external glass.

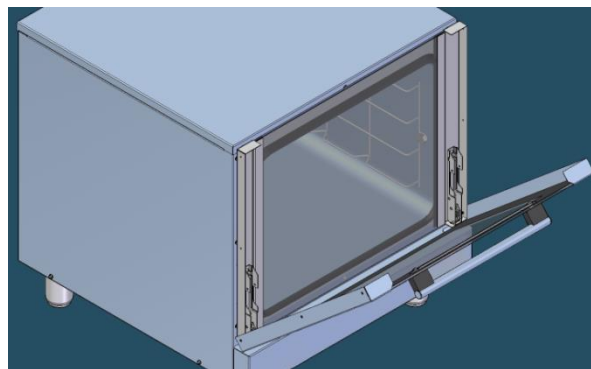

- 3) Clean the internal door glass with a mild detergent, warm water, and soft cloth.
- 4) Carefully dry the glass surfaces with a dry soft cloth.
- 5) Gently close the outer door assembly using the handle and fasten the (4) screws removed in step 1.

Internal door glass cleaning

(For ovens with horizontal door handle & removable door glass)

Before cleaning the inner door glass, let the door cool down completely.

1. Loosen the upper door profile screws.

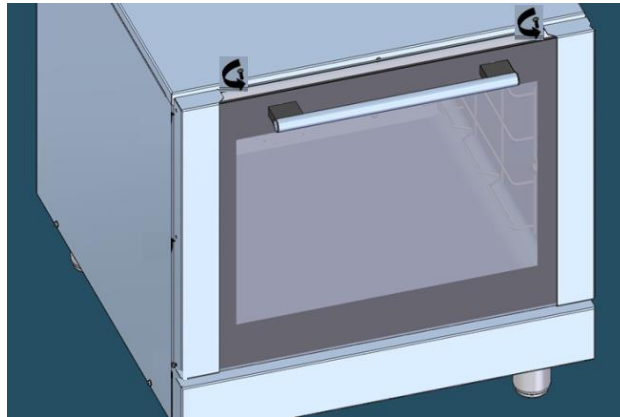

2. Open the oven door, remove the inner glass by pulling slightly.

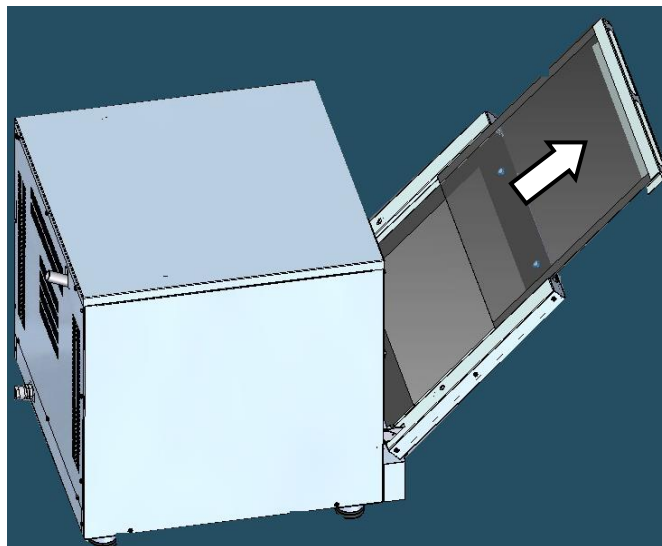

3. Repeat the operation in reverse order to reassemble the inner glass.

NOTE:

During the removal of the inner glass, make sure that the gaskets on the door column remain securely in place; otherwise reposition them in the appropriate location.

Door glass internal cleaning (For models with vertical door handle)

Before cleaning the inner door glass, let the door cool down completely.

- 1) With the oven door closed, loosen the upper, central, and lower screws on the door profiles.

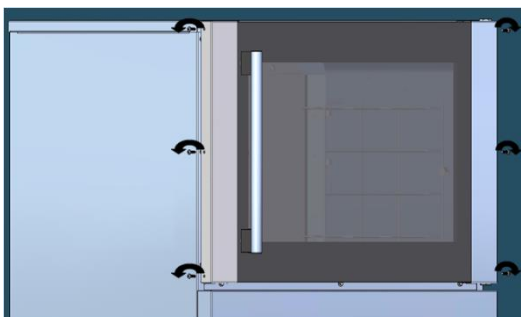

- 2) Use the handle to open the doors outer glass gently.

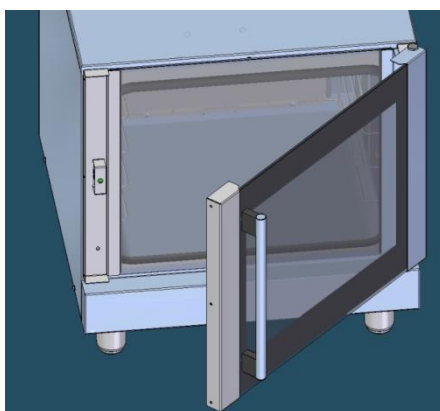

- 3) Clean the inner door glass with a mild detergent, warm water, and soft cloth.
- 4) Carefully dry the glass surfaces with a dry soft cloth.
- 5) Gently close the outer door assembly using the handle and fasten the (6) screws taken out in step 1.

Removing the oven door

To clean the oven door thoroughly, proceed as follows:

1. Fully open the door;
2. Insert the provided plugs into the holes marked "A" in the hinge (Fig. 4);
3. Lift the door gently and withdraw it (Fig. 5);
4. Put back the door in the initial position by operating inverserly.

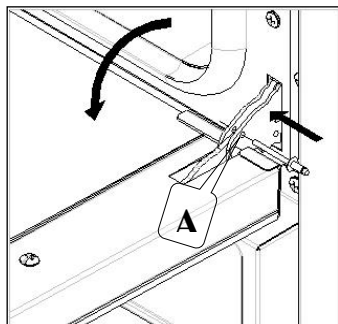

Fig. 4

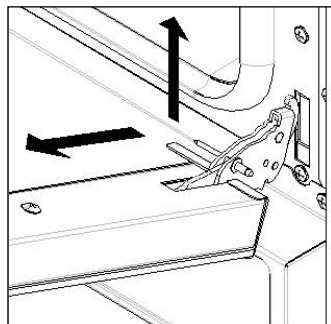
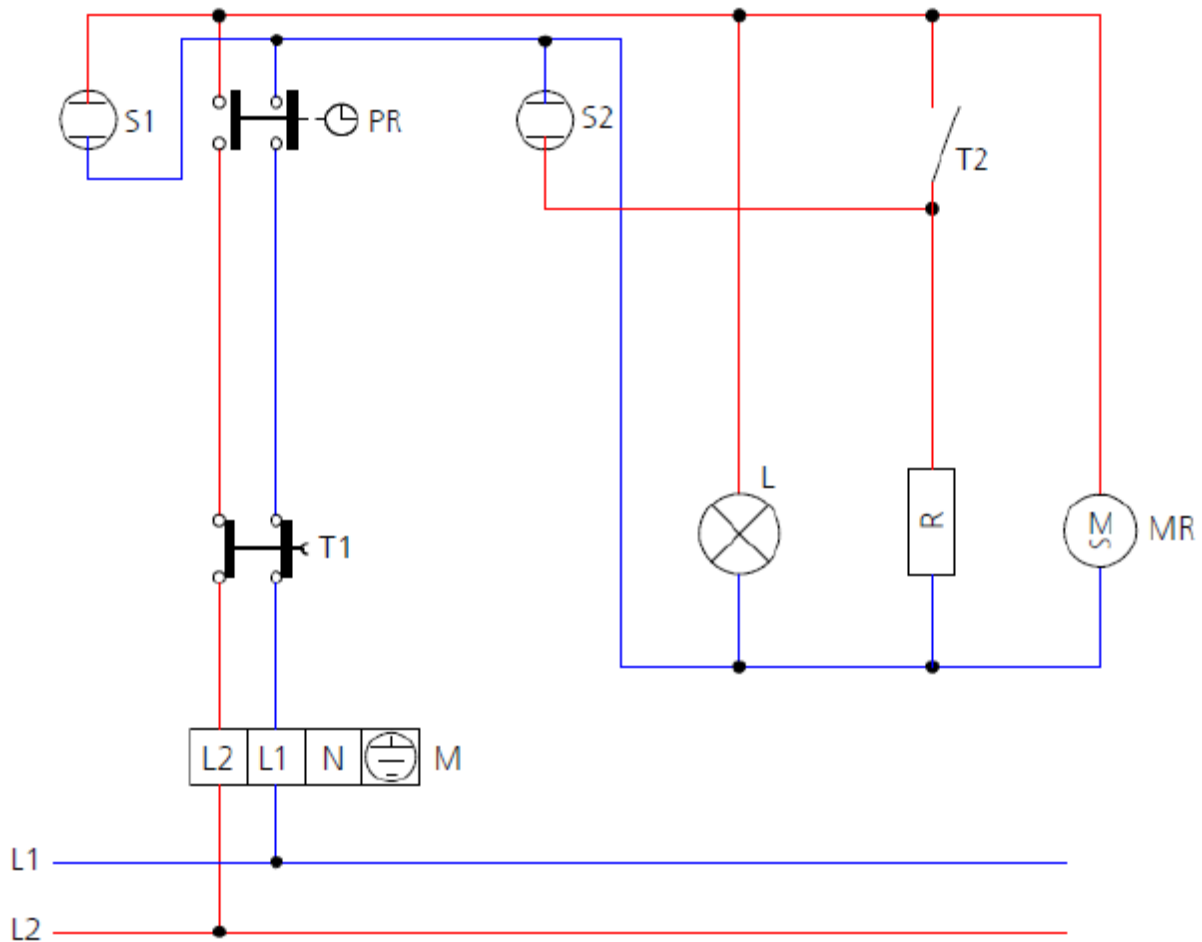

Fig. 5

TROUBLESHOOTING

Type of fault	Cause of the fault	Corrective action
The oven does not work	Incorrect connection to the power mains.	Check connection to the mains.
	Voltage not present.	Restore power supply voltage.
	Safety thermal device triggered.	Contact a skilled technician.
	Excessive heat at motor winding. Heat sources too close to the oven.	Contact Customer Service.
Cooking cycle set and activated: Oven not running/heating.	Door open or ajar.	Close the door properly.
	Damaged door switch.	Contact Customer Service.
Select steam in program or push manual steam button but no steam is created.	Incorrect connection to water mains.	Check connection to the water mains.
	Closed water valve.	Check that the water valve is open.
	Damaged or dirty water inlet filter.	Clean/replace the filter.
	Damaged water inlet solenoid valve.	Contact Customer Service.
Water/Steam escaping from around door while closed	Incorrect gasket assembly or not installed correctly.	Check gasket assembly for flaws.
	Damaged gasket.	Contact Customer Service.
	Loose hinge/handle assembly.	Contact Customer Service.
The oven does not cook evenly.	One of the fan motors is blocked or turns at low speed (in the event the oven has two motors).	Contact Customer Service.
	The fan motors are not reversing direction.	Contact Customer Service.
	Resistor damaged or lost power.	Contact Customer Service.
Light in the cooking chamber does not work.	Damaged or expired light bulb.	Replace the light bulb.
	Light bulb is loose.	Ensure the light is tight in socket.
	Damaged light socket.	Contact Customer Service.

6220-17 – Wiring Diagram



M	Power terminal board
PR	"End of cooking" programmer
T1	Safety thermostat
T2	Oven thermostat
S1	"End of cooking" indicator light
S2	Thermostat indicator light
L	Oven lighting lamp
MR	Radial motoventilator
R	Circular heating-element

6240 – Wiring Diagram

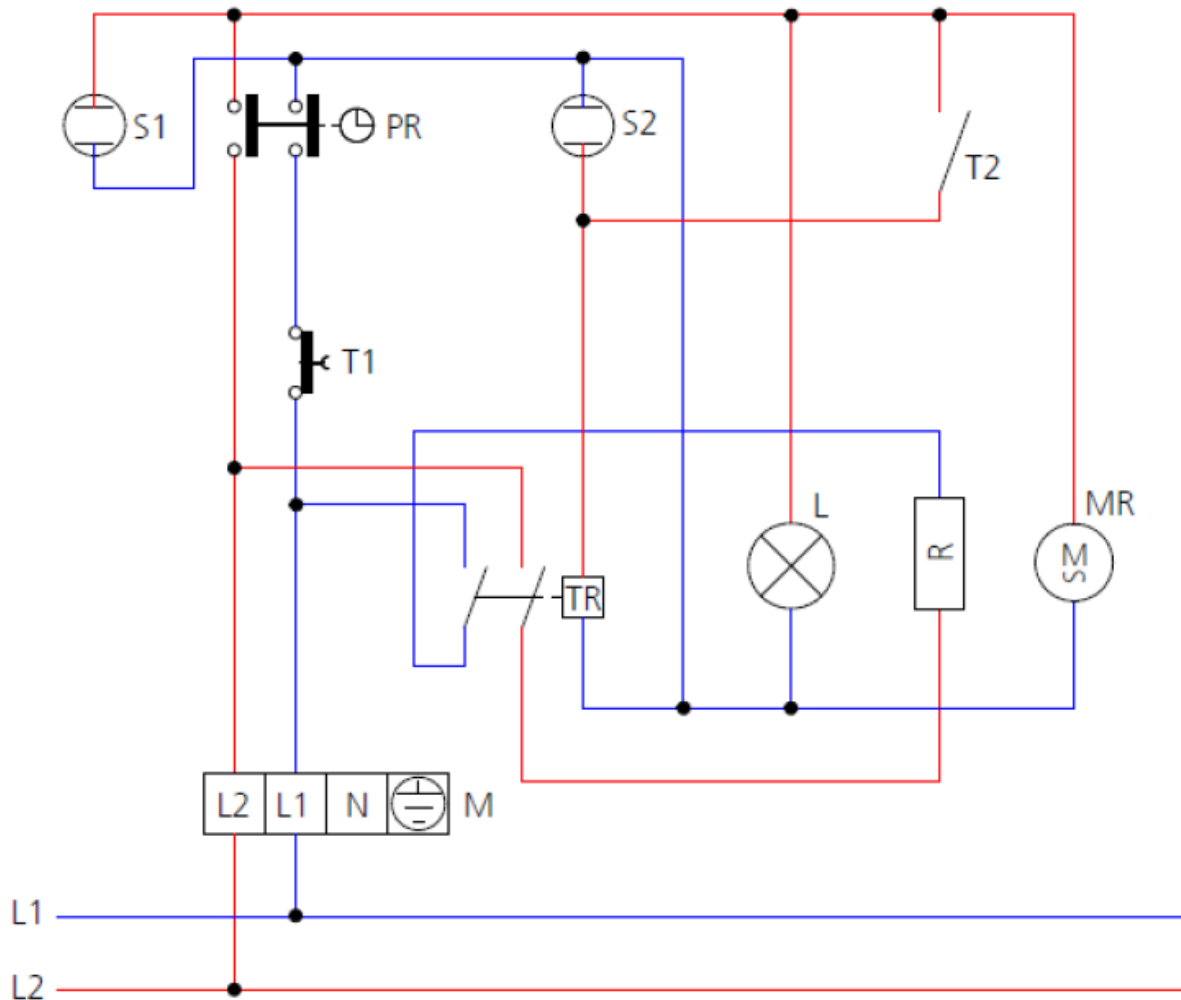

M	Power terminal board
PR	"End of cooking" programmer
T1	Safety thermostat
T2	Oven thermostat
S1	"End of cooking" indicator light
S2	Thermostat indicator light
L	Oven lighting lamp
MR	Radial motoventilator
R	Circular heating-element

6220-17 EXPLODED DRAWINGS

1/2

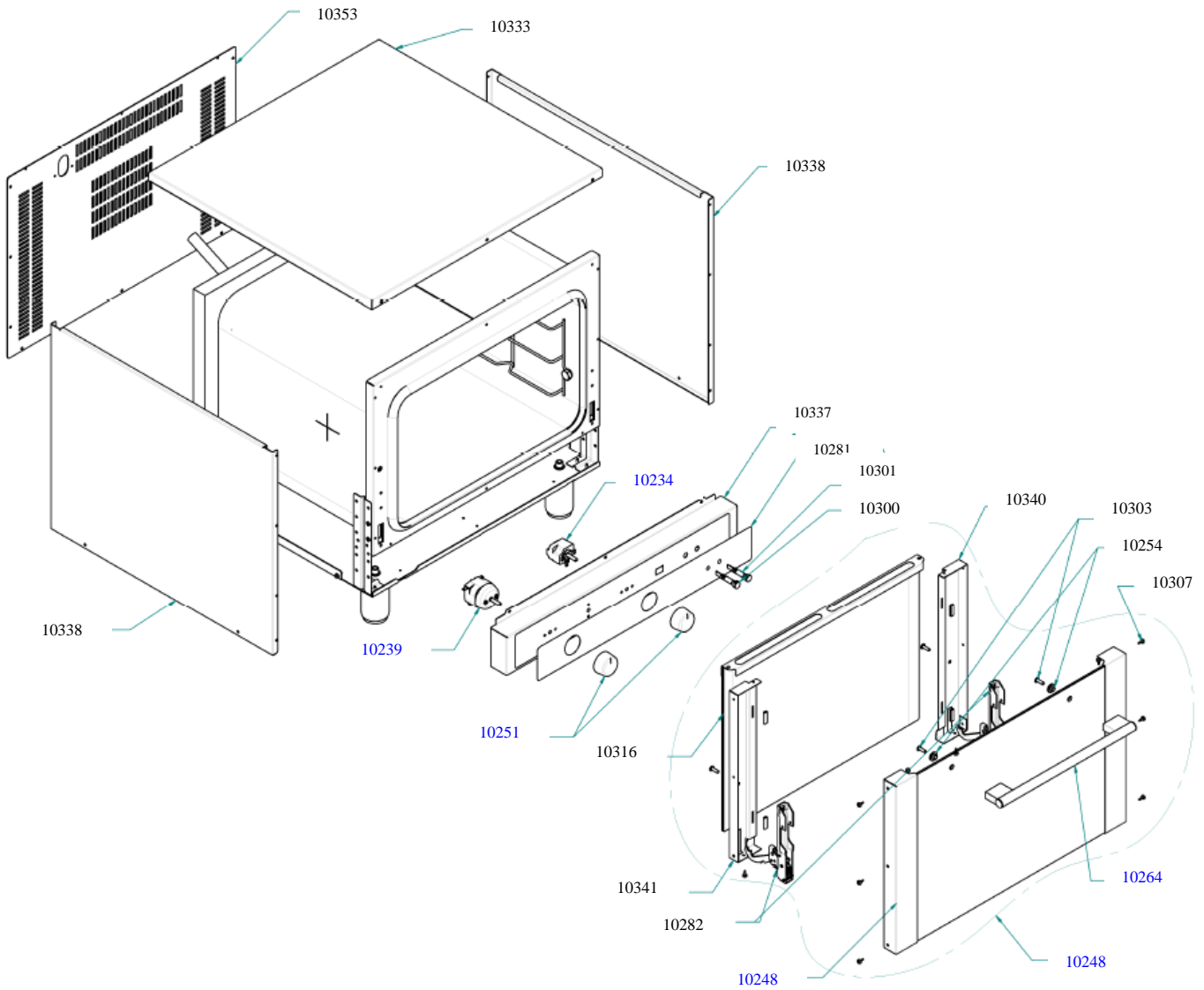

6220-17 EXPLODED DRAWINGS

2/2

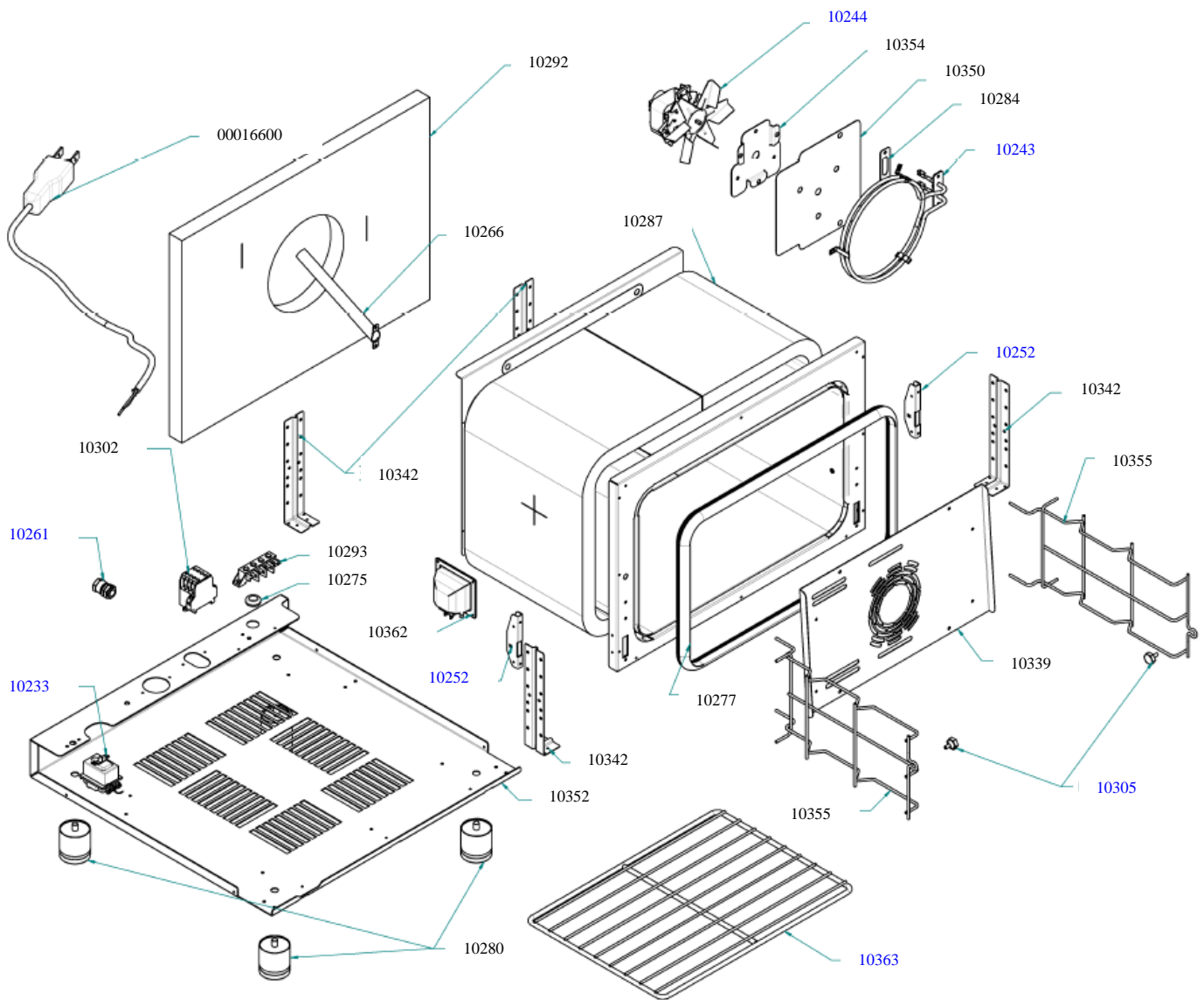

6220-17 SPARE PARTS

1/1

COMPONENT CODE	COMPONENT DESCRIPTION
10251	KNOB TIME OR TEMP
10252	DOOR HINGE BRACKET
10254	DOOR GLASS SPACER
10261	STRAIN RELIEF
10264	DOOR HANDLE
10266	EXHAUST PIPE
10362	SQUARE LIGHT ASSEMBLY
10275	WIRE BUSHING
00016600	POWER CORD
10280	2" LEGS
10244	FAN MOTOR
10281	CONTROL LABEL
10282	INTERNAL DOOR HINGE
10284	HEATING ELEMENT GASKET
10227	DOOR GASKET
10287	INSULATION
10292	INSULATION BACK
10293	TERMINAL BLOCK
10233	TWO POLE THERMOSTAT
10235	THERMOSTAT
10243	CIRCULAR HEATING ELEMENT
10300	GREEN PILOT LIGHT
10301	ORANGE PILOT LIGHT
10239	TIMER WITH ACOUSTIC SOUND
10302	MULTI-OPTION SWITCH
13303	SCREW
10305	HEX BOLT
10307	SCREW
10311	COMPLETE DOOR ASSEMBLY
10248	EXTERNAL GLASS
10316	INTERNAL DOOR & HINGE
10339	REAR COMPONENT CASING
10338	SIDE PANEL
10333	UPPER PANEL
10337	CONTROL PANEL COVER
10340	INTERNAL DOOR COLUMN LEFT
10341	INTERNAL DOOR COLUMN RIGHT
10342	CASE BRACKET
10350	FAN INSULATION
10352	BOTTOM PANEL
10353	BACK PANEL
10355	SHELF SUPPORT
10363	COOKING RACK

6240 EXPLODED DRAWINGS

1/2

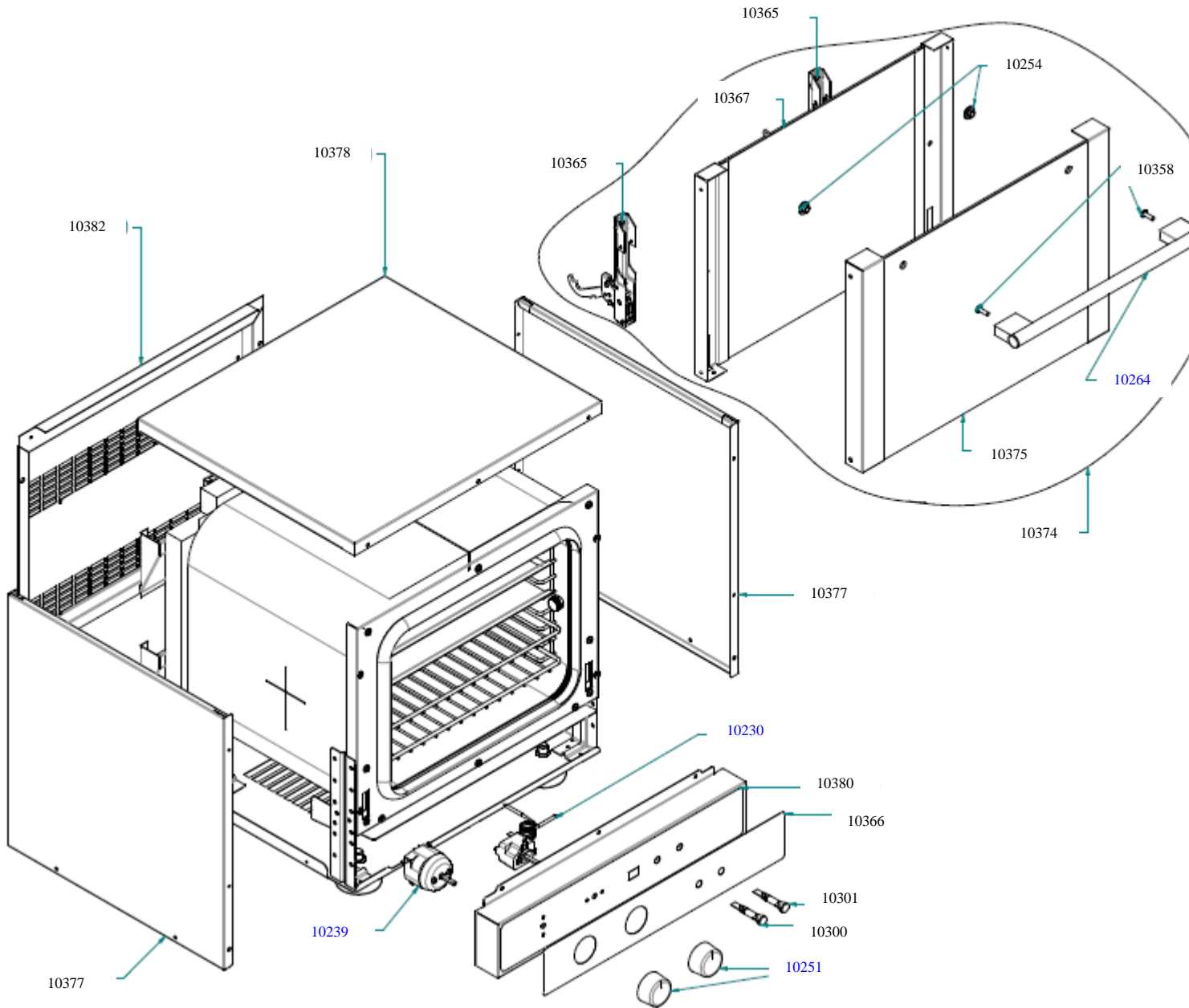

6240 SPARE PARTS

1/1

COMPONENT CODE	COMPONENT DESCRIPTION
10251	HORIZONTAL STEM KNOB
10252	HINGE BRACKET
10254	DOOR GLASS SPACER BUFFER
10261	CABLE GLAND PG 13,5
10264	PIPE HANDLE D18 C/2 BLOCKS
10386	CHIMNEY TO EXHAUST STEAM
10362	COMPLETE LAMP HOLDER
10279	POWER CABLE L=2000 MM WITH DIE-CAST PLUG 300V 15A
10365	HINGE
10280	FOOT H=56 MM
10366	FILM
10284	CIRCULAR AND LOWER RESISTOR GASKET
10367	RECES. GASKET MUFFLE FRONT
10368	MUFFLE STRIP GLASS WOOL PANEL
10369	MUFFLE BOTTOM GLASS WOOL PANEL
10370	TERMINAL BOARD FV 71
10230	ELECTRIC REGULATION THERMOSTAT
10371	UNIPOLAR THERMOSTAT
10372	MOTOR
10239	END OF COOKING
10243	CIRCULAR HEATING ELEMENT
10300	GREEN WARNING LIGHT
10301	ORANGE WARNING LIGHT
10302	CONTACTOR 110V-50//60Hz -20A
10358	GALVANISED SCREW TE M5X16
10373	HEXAGONAL RATCHET
10374	COMPLETE INSPECTION GLASS DOOR
10375	OUTER GLASS SILICONE SEALING ASSEMBLY + PROFILES
10376	INNER GLASS SILICONE SEALING ASSEMBLY + PROFILES
10377	RH/LH SIDE
10378	COVER
10379	STAINLESS STEEL AIR COVER
10380	DASHBOARD
10381	FEET
10342	OVEN COLUMNS
10382	BACK
10350	GLASS WOOL STOP PANEL
10383	BASE
10384	SIDE SUPPORT

PRODUCT WARRANTY

Except as otherwise provided below, Nemco Food Equipment, Ltd. ("Nemco") warrants, to the original user, its electrical/pneumatic products (other than blades and light bulbs) to be free of electrical and mechanical defects in material and workmanship under "normal use" (defined below) for the shorter of the following periods: (a) one (1) year from the date placed in service by the original user, or (b) 18 months from the date of shipment from its factory. Nemco also warrants its food preparation products (other than blades) to be free of mechanical defects in material and workmanship under normal use for two (2) years from the date placed in service by the original user. PaniniPro Sandwich Press to be free of electrical and mechanical defects in material and workmanship under "normal use" (defined below) for the following periods: (a) One (1) Year Labor, (b) Two (2) Year Parts. In addition, Nemco warrants its Global Solutions food preparation and electrical products (other than blades) to be free of mechanical defects in material and workmanship under normal use for one (1) year from the date placed in service by the original user. The warranty provided for herein shall be limited to parts and labor. Any determination that a product is defective or covered by this warranty, shall be made by Nemco, in its sole discretion. The determination of whether to repair or replace a defective, covered product, or to refund the purchase price for the product, will be at Nemco's sole discretion. This warranty does not cover products used outside the United States, or damages caused by accident, misuse, negligence of any person other than Nemco, current or voltage other than stated on the appliance, fire, flood or other casualty. Any alteration to the product or unauthorized repair voids this warranty. For purposes of this warranty, the phrase, "normal use" shall mean the use of the product in connection with food in accordance with the product manual accompanying the product.

Nemco shall be responsible only for repairs or replacements of defective parts performed by Nemco's authorized service personnel. Authorized service agencies are located in principal cities throughout the continental United States, Alaska and Hawaii.

THE FOREGOING WARRANTY IS EXCLUSIVE AND IN LIEU OF ALL OTHER WARRANTIES, EXPRESS OR IMPLIED. NEMCO EXPRESSLY DISCLAIMS ANY IMPLIED WARRANTY THAT ANY OF ITS PRODUCTS IS MERCHANTABILITY, FIT FOR A PARTICULAR PURPOSE, OR DOES NOT INFRINGE ON THE RIGHTS OF ANY THIRD PARTY. THE FOREGOING WARRANTY SHALL BE NEMCO'S SOLE AND EXCLUSIVE OBLIGATION. ANY PERSON'S (BUYER, USER OR OTHERWISE) EXCLUSIVE REMEDY AGAINST NEMCO, AND NEMCO'S SOLE OBLIGATION, FOR ANY AND ALL CLAIMS, WHETHER FOR BREACH OF CONTRACT, WARRANTY, TORT (INCLUDING WITHOUT LIMITATION NEGLIGENCE), OR OTHERWISE, SHALL BE LIMITED TO NEMCO REPAIRING OR REPLACING THE PRODUCT, OR, AT NEMCO'S OPTION, REFUNDING THE PURCHASE PRICE THEREFOR. IN NO EVENT SHALL NEMCO HAVE ANY LIABILITY FOR DAMAGES IN AN AMOUNT EXCEEDING THE PURCHASE PRICE OF THE PRODUCT, NOR SHALL NEMCO HAVE ANY LIABILITY FOR INCIDENTAL, SPECIAL OR CONSEQUENTIAL DAMAGES. Any person desiring to make any claim against Nemco must do so within six (6) months after expiration of the applicable warranty period, or such claim shall be forever barred.

NOTE: WARRANTY DOES NOT COVER DAMAGE TO THE GRID, GRID COATING OR NONSTICK COATING. IT IS NEMCO'S SOLE DISCRETION TO DETERMINE IF A GRID, GRID COATING OR NONSTICK COATING CLAIM IS WARRANTED.

NOTE: WARRANTY DOES NOT COVER DAMAGE TO THE ROLLERS OR ROLLER COATING. IT IS NEMCO'S SOLE DISCRETION TO DETERMINE IF A ROLLER OR ROLLER COATING CLAIM IS WARRANTED.

NOTE: PLEASE REVIEW YOUR PRODUCT MANUAL FOR SPECIFIC WATER REQUIREMENTS. DISTILLED OR TREATED WATER MAY BE REQUIRED. PRODUCT FAILURE DUE TO SEDIMENT AND LIME BUILDUP IS NOT COVERED UNDER WARRANTY.

PRODUCT SERVICE

Nemco has a staffed service department, and we believe prompt service is extremely important to our customers. Therefore, we request all product service inquiries be handled in the following manner:

1. The end user should call Nemco Customer Service with the company name, address, phone number, model number, serial number (if applicable), Nemco Sales Order number or Dealer Purchase Order number and the nature of the problem (the "Claim Information").
2. The Nemco Customer Service Department will decide on the most appropriate course of action. If Nemco determines that it must inspect a product, the following procedure will be followed:

The end user will obtain a Return Goods Authorization number from Nemco Customer Service to return the product to Nemco for inspection. Please be sure to use this number on the box and on paperwork sent with the unit. Return the unit to Nemco. The Nemco Service Department will determine if the problem is covered by the foregoing warranty. If so, Nemco will repair the unit and return it to the end user. If the unit is determined not to be covered by the foregoing warranty, the dealer will be contacted to determine the next course of action. If the unit weighs less than 70 lbs., it will be considered a carry-in warranty. The service agent performing the service must call Nemco Customer Service to obtain a Service Authorization number and provide the Claim Information. If the unit weighs 70 lbs. or more, it will be considered an on-site warranty, and the service agent performing the service must call Nemco Customer Service to obtain a Service Authorization number and provide the Claim Information.

TERMS & CONDITIONS

- No merchandise shall be returned without prior written authorization.
- All returned merchandise must be unused, in original carton and shipped prepaid.
- All returned merchandise is subject to a 25% restocking charge.
- No returns will be accepted after 90 days of shipping date.
- Purchaser should make claim directly to carrier for any damages to merchandise that occur in transit.
- This Price List supersedes all previous price lists.
- Orders with an invoice value of \$2,100 net or more will be shipped freight prepaid to one destination in the continental United States.
- Terms are COD, CIA or Net 30 days with approved credit.
- Buyer shall pay all applicable federal, state and municipal sales or use tax.
- No minimum order charge.
- Prices subject to change without notification.

nemco® | FOOD
EQUIPMENT

301 Meuse Argonne Hicksville, OH 43526 • P:800.782.6761 • F:419.542.6690

Visit us at www.nemcofoodequip.com for more information

Nemco	Global Solutions	Tecnoeka
6220-17	GS1105-17	EKFA 312 S (1700 W)
6240	GS1130	EKFA 414 S (1700 W)

Approvals / Listings for Nemco Convection Ovens:

Our convection ovens are manufactured to Nemco Food Equipment Company specifications by Tecnoeka Srl, Italy.

All have ETL LISTED and ETL SANITATION LISTED approved by INTERTEK:

1) SAFETY: All units are approved to the **Commercial UL** for use without a mechanical ventilation system **IF** local codes permit.

A representative sample of the listed devices have been tested, investigated and found to comply with the requirements of the Standard(s) for Commercial Electric Cooking Appliances (UL-197) and are identified with the ETL Listed Mark.

2) SANITATION: All units are approved to **NSF Standard**.

A representative sample of the listed devices have been tested, investigated and found to comply with the requirements of the Standard(s) for Commercial Cooking, Rethermalization and Powered Hot Food Holding and Transport Equipment (NSF-4) and are identified with the ETL Sanitation Listed Mark.

The above mentioned certifications are listed under the oven manufacturer, Tecnoeka Srl.