



nemco[®] | FOOD
EQUIPMENT

Model # 6245

USER MANUAL

CAPACITY

- (4) 18 in x 13 in / 460 mm x 330 mm half size pan

STANDARD EQUIPMENT

- (2) 4-level shelf holders, 2.92 in (74 mm) spacing

FUNCTIONAL FEATURES

- Temperature range from 200°F to 500°F
- Cooking timer up to 9 hours and 59 minutes or run on infinite for continuous heat
- 2 cooking options available:
 - convection cooking
 - convection cooking with humidity
- Humidity available in manual or automatic mode (from 10% to 100%)
- 4 cooking phases available
- Available cooking cycle delay up to 9 hours and 59 minutes
- Maintain food temperature and quality by combining heat and humidity
- Automatic pre-heating for programmed cooking cycles

CONSTRUCTION FEATURES

- Stainless steel constructed cooking chamber and shell
- Glass door to facilitate cooking and cleaning operations
- Reversing fan motor to guarantee cooking uniformity
- Recessed gasket to guarantee a sealed cooking chamber

CONTENTS

TECHNICAL DATA	Page. 3
INTRODUCTION	Page. 5
Identifying the danger or warning signals	
Purpose of the product	
INSTALLATION	Page. 5
Installation requirements	
Transport	
Unpacking	
Installing the feet	
Placement	
Electrical connection	
Water connection	
Water drain	
Conditioning the appliance	
OPERATION INSTRUCTIONS	Page. 8
Controls	
General cooking information	
CLEANING AND MAINTENANCE	Page. 11
Outer stainless steel surfaces	
Side supports	
Air cover	
Light bulb	
Door gasket	
Cooking chamber	
External door glass	
Internal door glass	
TROUBLESHOOTING	Page. 16
WIRING DIAGRAM	Page.17
EXPLODED DRAWINGS AND SPARE PARTS	Page. 18
PRODUCT WARRANTY	Page.21
PRODUCT SERVICE	Page. 21
TERMS & CONDITIONS	Page. 21

6245 – Digital Oven

INSTALLATION REQUIREMENTS

- The oven must be positioned on a level surface
- Hot surfaces must comply with the minimum distance from the oven:
 - Left Side: 19.7 in (500mm)
 - Right Side: 19.7 in (500mm)
 - Rear Panel: 19.7 in (500mm)
- Other surfaces must comply with the minimum distances from the oven:
 - Left Side: 3.94 in (100mm)
 - Right Side: 3.94 in (100mm)
 - Rear Panel: 3.94 in (100mm)

SIZE SPECIFICATIONS

Weight without packaging:	95.7 lbs (43.4 kg)
Height without packaging:	25.82 in (656 mm)
Width without packaging:	23.62 in (600 mm)
Depth without packaging:	27.83 in (707 mm)
Weight with packaging:	106.7 lbs (48.4 kg)
Height with packaging:	23.62 in (600mm)
Width with packaging:	26.77 in (680mm)
Depth with packaging:	29.92 in (760mm)

MAXIMUM LOAD PER PAN

3.5 lbs (1.5 kg)

OPERATION ELECTRICAL REQUIREMENTS

Voltage (V)	Amperage (A)	PH	Hz	AWG	Connection	Watts (W)	Type of Plug
208/240	11.5 / 13.0	1	60	12	L1, L2/N, G	2750 / 2900	NEMA 6-20

WATER QUALITY REQUIREMENTS

To guarantee correct operation of the appliance, the inlet water must be suitably treated in order to reach the requirements below:

Without Chlorine	→	Less than 0.1 ppm (mg/L)
Hardness	→	30-70 ppm
Chlorine	→	Less than 30 ppm (mg/L)
pH	→	From 7.0 to 8.5
Silica	→	Less than 12 ppm (mg/L)
Total Dissolved Solids (TDS)	→	50-125 ppm

Failure to comply with these requirements may damage the appliance and/or its internal components. The manufacturer is not liable for damage resulting from failure to comply with the water specifications above. Failure to comply will void the warranty.

6245 – Overall Dimensions

Front View

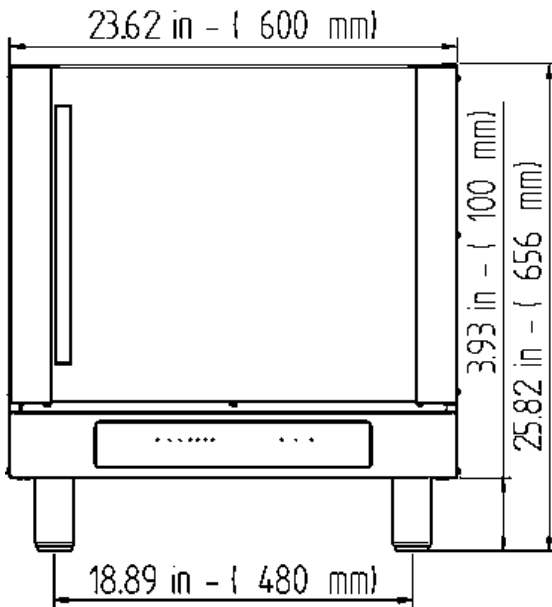

Side View

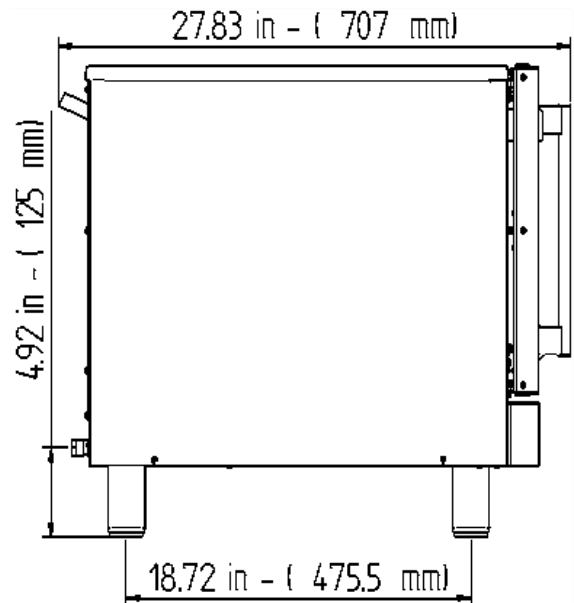

Rear View

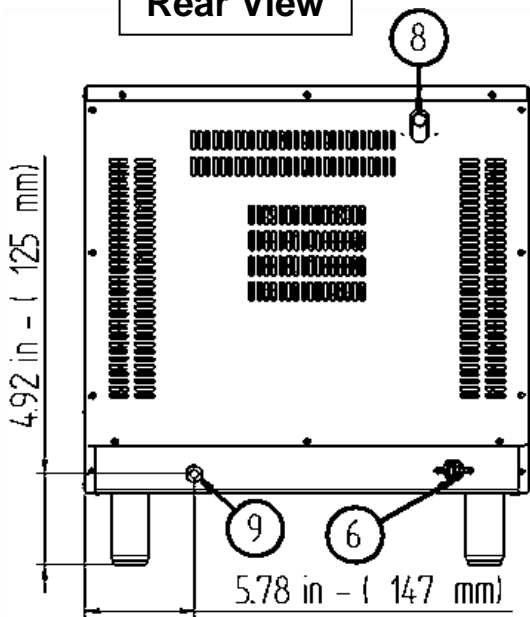

**Top View
Door Open**

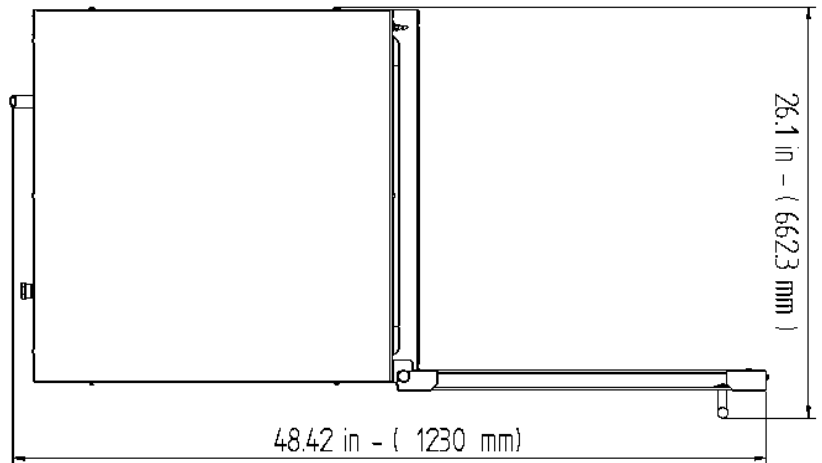

6	Water Inlet
8	Steam Exhaust Pipe
9	Power Cord Strain Relief

INTRODUCTION

Carefully read this user manual before using your new oven; pay special attention to the information highlighted with the **WARNING**, **CAUTION**, and **NOTES** symbols

Identifying the danger or warning signals:



WARNING

This signal indicates the presence of **danger, which may cause serious injury, death, or damage** if disregarded.



CAUTION

This signal indicates the presence of **danger, which may cause slight injury or damage** if disregarded.

NOTES

Notes aim at indicating details or recommendations regarding installation, operation, or maintenance. Notes contain important information, which is not related to possible risks.

This appliance has been specifically designed for food cooking. Any other use is considered improper.

INSTALLATION

	CAUTION
	Risk of injury. Wear protective gloves during installation operations.

Installation requirements:

- All installation and conditioning operations must be performed by a technically skilled installer, following the manufacturer's instructions.
- Comply with the instructions contained in this user manual. The manufacturer shall not be liable for damage or harm to persons or property arising from installation errors. Nor are they responsible for any appliance breakage caused by faulty installation.

Transport



During transport the appliance must be kept in its packaging in order to protect it from any external damage.

Unpacking

- Remove the oven external packaging and make sure that the appliance has not been damaged during transport. Inform the shipping company in the event damage is detected.
- Remove any loose contents from the oven that are not intended for use during operation.
- Carefully remove the plastic film that protects stainless steel components.

Remove any glue residue, which may result from removing the protective film, using a non-flammable solvent.

Installation of the feet

	 WARNING
	Risk of fire. This appliance has been designed to operate with specific feet. Do not use the appliance without installing the feet first. Using the appliance without feet may cause fire due to overheating.

If the feet are not installed on the appliance, they are inside the cooking chamber and must be screwed into the four threaded holes on the underside of the oven.

Placement

- Place the appliance on a perfectly level work surface.
- Should the appliance be installed near walls, shelves, or ceilings they must be of the non-flammable or heat-insensitive type; otherwise, they must be protected by an adequate fire retardant coating.

NOTES

The appliance is unsuitable for recessing.

The following minimum distances from heat sources must be complied with to guarantee correct ventilation of the appliance's electric component compartment:

Rear panel: 19.7 in / 500mm
Left side: 19.7 in / 500mm
Right side: 19.7 in / 500mm

And from near surfaces:

Rear panel: 3.94 in / 100mm
Left side: 3.94 in / 100mm
Right side: 3.94 in / 100mm

Do not obstruct the natural and/or forced ventilation openings on the appliance's exterior.
Do not obstruct the appliance's smoke/steam exhaust pipe.

Failure to comply with these notes **WILL** omit the manufacturer from any liability and will deem the warranty invalid.

Electrical Connection

NOTES

- Before making the connections, make sure that the voltage and frequency of the power supply system match the specifications of the "technical data" plate affixed to the appliance.
- The appliance must be connected to a suitable electrical system following the connection data located on the sides of the machine.
- If the power cord is damaged, it must be replaced by the manufacturer or a qualified service technician.

- If the oven is placed on a wheeled table, the connection conduit must be flexible. The table wheels must be locked.

Appliances supplied with power cord already fitted:

Make sure that a suitable power cord and plug have been connected to the oven.

Appliances supplied without power cord:

NOTE Any electric connection must be made by qualified service technician.

Remove the appliance's rear/side panel (depending on the model) to access the terminal block. Apply the conduit and allow enough wire to pass through to reach the terminal block. Connect the **hot legs** to terminals “L1” & “L2” of the terminal board and the **ground** to the terminal with the following symbol ⊕. Replace the appliance's rear/side panel once the operation is complete.

NOTES

- The electrical system must be fitted with a pole circuit breaker with rated breaking current equal to 150% of the current consumed by the appliance.
- The circuit breaker must be installed near the appliance, but not behind it, and the operator must be able to access it any time.
- The circuit breaker must be clearly marked and easily accessible in case of fire.

Water Connection

The appliance **MUST** be hooked up to a softened water supply that meets the water specifications below. It is **necessary to use a softener, filter system, and/or reverse osmosis system** to achieve this water purity and limit the formation of lime scale inside the cooking chamber.

The water pressure must range between 14.5psi (100 kPa) and 29 psi (200 kPa).

If the pressure from the main water line exceeds 29psi (200 kpa), install a pressure reducer upstream of the appliance.

If the value is lower than 14.5 psi (100 kpa) use a pump to raise the pressure. The water temperature must not exceed 86°F (30°C).

Connection to the water mains must be performed through the ¾” threaded solenoid valve located at the rear (bottom) of the appliance, interposing a mechanical filter and a stopcock (before connecting the filter drain off a certain amount of water to flush the pipe from any dirt).

To guarantee the correct operation of the appliance, the inlet water must be suitably treated to reach the requirements below:

Without chlorine	→	Less than 0.1 ppm (mg/L)
Hardness	→	30-70 ppm
Chloride	→	Less than 30 ppm (mg/L)
pH	→	from 7.0 to 8.5
Silica	→	Less than 12 ppm (mg/L)
Total dissolved solvents (TDS)	→	50-125 ppm

Failure to reach these specifications will damage the appliance and/or its internal components.

NOTE Any damage caused by limescale or other chemicals contained in the water **ARE NOT** covered by warranty.

NOTE The equipment must be installed with adequate backflow protection to comply with applicable federal, state, and local codes.

Conditioning the Appliance

- Before the ovens first use it is recommended to run it with an empty cooking chamber for 60 minutes at a temperature of 400°F. This will reduce the unpleasant, yet normal smells that come from heating the insulation that is wrapped around the cooking chamber and the silicone used for external sealing are dissipated.
- Refer to the "Operation Instructions" section for any details on how to use the oven correctly.

OPERATION INSTRUCTIONS

CONTROL PANELS

The keys on the control panel should only be activated with your fingers, any other object or tool may cause damage and/or malfunctioning, hence forfeiting the product's warranty.

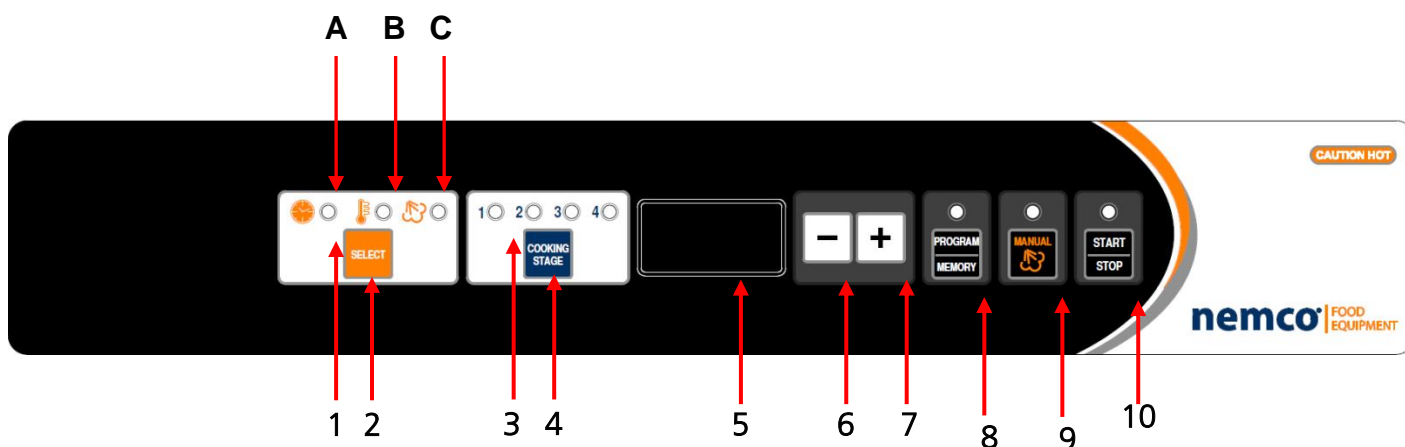

1) LED Signalling Active Parameter	6) Button to Decrease Parameter Value
2) Button to Select Cooking Parameters	7) Button to Increase Parameter Value
3) LED Signalling Active Phase	8) Button to Select/Store Cooking Program
4) Button to Select Cooking Phase	9) Manual Humidity Button
5) Digital Display	10) "START/STOP" Button
A) "Time" Active Parameter	B) "Temperature" Active Parameter
C) "Humidity Percentage" Active Parameter	

Powering On



The control panel automatically turns on as soon as the oven is electrically powered.

"r.XX" appears on the display for approximately 2 seconds ("XX" represents the revision number of the firmware included on the control board, for example "r.0.7").

Then "0.00" appears on the display to indicate time (expressed in hours and minutes) and the time LED turns on in the parameter field (🕒). The phase 1 LED turns on in the "phase" field (set to receive cooking parameters).

Powering Off









If no keys are pressed ten minutes after the completion of a cooking cycle the control panel switches off automatically (in "manual" or "automatic" mode, whether it ends automatically or by pressing the  key).

The display and the LEDs relative to the operative functions switch off; only the LED relative to the  key remains on. To reactivate the control panel just press the  key.

Operating Instructions

The cooking cycle can be carried out in "manual" or "programmed" mode and it can be divided into 4 phases. For each phase, it is possible to set the time, temperature, & humidity cooking parameters.

MANUAL MODE

- To select the cooking parameters (time, temperature, & humidity) press the  key. Every time the key is pressed, the LED relative to the selected parameter is activated. The time and cooking temperature parameters must be set for the cooking cycle to start.
- To select the phases (1, 2, 3, or 4) of the cooking cycle, press the  key. Every time the key is pressed, the LED corresponding to the selected phase is activated. With a cooking cycle in progress, the phase is signaled by the corresponding flashing LED.
- To set or change the value of the selected parameter use the   keys.
- Press key  to increase the parameter value,
- Press key  to decrease the parameter value.
- The time parameter () may be set from 0 hours and 01 minute to 9 hours and 59 minutes. If the display reads "INF" or "HLD" this means time counting is excluded, the oven runs nonstop until the  key is manually deactivated.



If the display reads "INF" (only available for step 1) steps 2, 3, & 4 will no longer be available (LEDs off).

If the display reads "HLD" (only available for step 4) this means that after completing the previous steps, the cooking cycle continues with no time counting with the parameters set for step 4. (The cooking cycle is deactivated by pressing the  key). This option allows the user to keep the food "warm" (at the end of the cooking cycle) for the desired length of time.



The temperature parameter () may be set from 200°F to 500°F (for your convenience a temperature of 356°F is already set)

The humidity parameter () can be set from 0% to 100% (100% being continuous steam).

Starting/stopping the cooking cycle



The cooking cycle starts and stops by pressing the  key. Upon completing the cooking cycle the elements, motors, and water solenoid valve are deactivated. The buzzer sounds for 30 seconds, the digits "0.00" flash on the display and the temperature/humidity parameters of the last phase remain set. If extra time is added during the 30 seconds, the oven restarts automatically and cooking continues with the temperature/humidity parameters of the last phase used. After the completion of the extra time, the cooking cycle ends permanently. If you let the 30 seconds expire or if the cooking cycle is interrupted by pressing the  key, all the set parameters are reset and the oven is ready for setting a new cooking cycle.

Display / modify parameters with cooking cycle active



While in a cooking cycle, parameters may be displayed by pressing the  key and for each phase of the cooking cycle the values will be shown and may be modified ( ). After a few seconds have elapsed from the last modification made (for any of the 4 phases), the display defaults back to showing the parameters of the current phase (flashing LED on the phase in progress).

If selecting the:

"Time" parameter

The display shows the value set for the selected step for 4 seconds (steady LED on the  symbol), and for 4 seconds the total remaining time (COUNT DOWN) for the remaining phases (LED flashing on  symbol).

"Temperature" parameter





The display shows the value for the selected phases for 4 seconds (steady LED on the  symbol) and for 4 seconds the temperature measured inside the cooking chamber (LED flashing on the  symbol)



“Humidity/steam” parameter



The display shows the value set for the selected phase (steady LED on symbol .

Delayed cooking cycle instructions

To delay the start of the cooking cycle follow below instructions:

- Set the desired parameters for each step of the cooking cycle, following the instructions shown in paragraph “Operating Instructions” (paragraph 10)
- Press the  key until all the signaling LEDs on the control panel go out and the display reads “0.00”
- Press  /  key and set the desired “DELAY TIME” on the display (maximum 9 hours and 59 minutes)
- Press the  key to begin the delayed start cycle.

The LED of the  key flashes to signal the “COUNT DOWN” shown on the display is active. The set “DELAY TIME” may be modified at any time during the “COUNT DOWN” by pressing the  /  keys. Upon expiration of the set “DELAY TIME” the cooking cycle will automatically begin.

To reset the “DELAY TIME” press the  key; the display shows again the parameters which may be modified. If the  key is pressed, the cooking cycle starts regularly; otherwise, a delayed start of the cooking cycle may be set again by repeating the above instructions.

Please note





In the event of power loss during the “COUNT DOWN”, delayed programming of the cooking cycle is cancelled and the parameters are reset. Delayed start of the cooking cycle is only possible in “MANUAL MODE”. It cannot be inserted in a programmed cooking cycle.

“Programmed” mode.

Create and store up to 99 cooking programs. Utilize 1 to 4 different cooking phases within each program.





Cooking program storage

Follow the below instructions to store a cooking program:

- Press the  key (LED switches on) the display reads “P01”.
- Use the   keys to choose the desired program number (up to P99).
- Set the cooking cycle parameters following the same procedures as the “manual” mode.
- Press the  for at least 5 seconds: program storage is confirmed by flashing the stored program number on the display.
- Follow these instructions to modify or replace existing programs.

Cooking with stored program

Use the following instructions to use a stored cooking program:



- Press the  key, the display reads “P01”.
- Press the   keys and choose the desired program number.
- Press the  key, the program will begin running.

The display shows “P – H” (indicating cooking chamber is in “pre-heating” function). The heating elements run until reaching a temperature 86°F higher than the value set for phase 1 of the programmed cycle. When the preheating temperature is reached, the display flashes “P – H” and the buzzer sounds. Now the oven door must be opened, place product in the oven, and close the door. The buzzer stops and the programmed cooking cycle begins at the desired temperature.

Please note

The "automatic preheating" function is only available when cooking in the "programmed" mode. Parameters that have already been set may be modified even in "programmed" mode. Upon completing the programmed cooking cycle, the modified parameters automatically "reset" and resume the value initially stored in the program.

Manual humidity/steam



With an active cooking cycle (both in "manual" and "programmed" mode), it is possible to produce humidity/steam at any time inside the cooking chamber by pressing the  key (LED on). The humidity/steam production continues for as long as the key is pressed. If an automatic humidification cycle is in progress, pressing the  key will interrupt the cycle, but when the key is released the automatic humidification cycle resumes.

GENERAL INFORMATION ON COOKING



"Convection" cooking

Using the  key, set the "time" and "temperature" parameters for each necessary phase (). Start the cooking cycle by pressing the  key.

Convection cooking + humidity/steam

With the  key, set the "time", "temperature", and "humidity" parameters for each necessary phase (). Start the cooking cycle by pressing the  key.

CLEANING AND MAINTENANCE

	 WARNING
	Risk of electrocution. Disconnect the appliance's power supply before performing cleaning and maintenance operations.
 CAUTION	
The oven is not waterproof. Do not submerge in water, spray with water jets, or steam to clean the inside or outside of the oven.	

NOTES

- Clean regularly and thoroughly.
- **DO NOT** use abrasive cleaning pads or detergents that may damage the oven. Use specified products only.
- At the end of every cleaning operation, make sure that any material used has been fully removed.
- If faults are detected, refer to the Troubleshooting guide (p. 16) and immediately perform maintenance to solve the issue. Do not wait for the component to fully break.

- Adapt the oven cleaning frequency based on its use.
- Before cleaning the appliance, allow it to cool down to room temperature.



Complete Cleaning Instructions

Outer stainless steel surfaces

The outer steel surfaces must be cleaned with a cloth soaked in warm soapy water or mixed with a small amount of vinegar. Once cleaned completely the surfaces must be rinsed using a cloth soaked in only warm water and then dried with a dry soft cloth. If using other chemical products, make sure they do not contain abrasive, acid, or corrosive substances. The counter supporting the appliance and/or the floor surrounding the appliance area should also be cleaned using the same methods. Using the chemicals mentioned may corrode and deteriorate the outer stainless steel shell and cause non-reparable damage to the electrical components inside the appliance.

Side supports

- 1) Loosen the (2) hex head bolts (turn counter-clockwise) that fasten the side support to the cooking chamber.

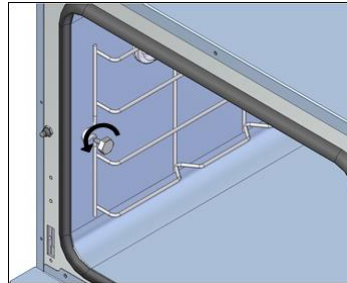

- 2) Pull the side supports towards the door to remove them from the air cover panel.
- 3) Remove the side supports from inside the oven and clean them with a mild detergent and hot water, using a soft bristle brush.
- 4) Carefully dry the side supports with a dry cloth.
- 5) Insert the side supports back into their positions on the oven air panel.

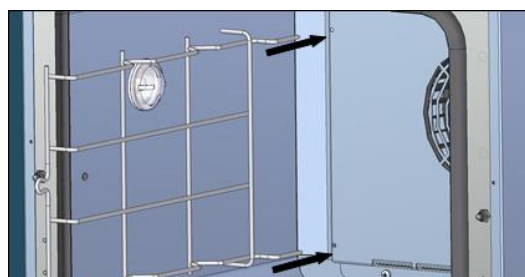

- 6) Fasten the side supports to the oven's cooking chamber using the (2) hex head bolts previously removed.

Air cover

- 1) Remove the side supports from the cooking chamber, following the "Side Supports" instructions provided.
- 2) Remove the (4) screws that fasten the air cover to the cooking chamber.

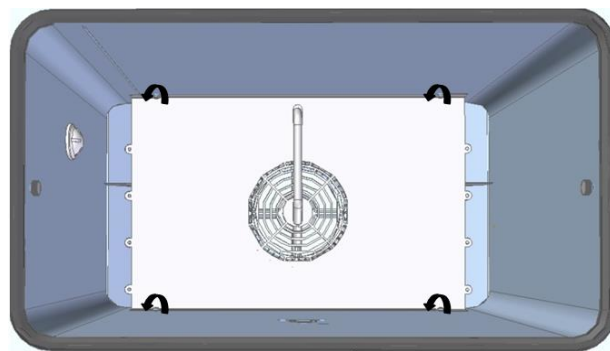

- 3) Remove the air cover from inside the oven and clean it with a mild detergent and hot water, using a soft bristle brush.
- 4) Carefully dry the air cover with a dry cloth.
- 5) Fasten the air cover to the oven's cooking chamber using (4) the screws previously removed.

Replacing the light bulb

For ovens with square light bulb covers

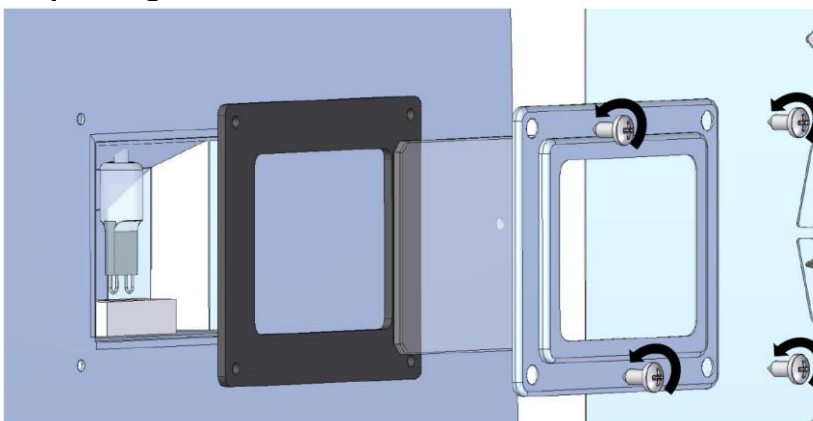

- 1) Remove the side supports from the cooking chamber, following the indications provided.
- 2) Unscrew the screws that secure the glass support and the relative seal.

- 3) Use a dry cloth to remove the light bulb from its socket and replace it with an exact match.
- 4) Reassemble the glass support and its gasket.

Door gasket - cleaning

- 1) Remove the gasket by pulling a small section until it is free from the guide. Continue pulling to fully remove the gasket. Please remember that the door gasket has a rigid profile with retainer fins (B). This profile must be pressed into the guide on the front of the cooking chamber.

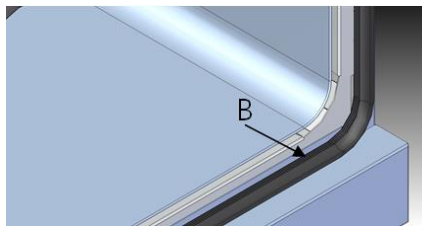

- 2) Inspect the door gasket and make sure there are no cuts or damage. If damages are found, the gasket should be replaced immediately as cooking will vary with an unsealed chamber.
- 3) If the gasket is intact, carefully wash it in a sink with soap and warm water.
- 4) After cleaning the gasket, carefully dry with a soft cloth.
- 5) Reposition the gasket inside the guide on the front of the cooking chamber, following the installation indications provided in point 1.
- 6) Press the gasket into the guide, making sure there are no gaps and the gasket is seated tightly.

Cooking chamber - cleaning

Before cleaning the cooking chamber, let it cool down to room temperature.

- 1) Remove the side supports and the air cover from the oven's cooking chamber, following the previous instructions.
- 2) Carefully clean all the parts of the cooking chamber with a mild detergent and hot water, using a soft bristle brush.
- 3) Carefully dry the oven with a dry cloth.
- 4) Remount the side supports and the air cover following the previous instructions.

External door glass cleaning

Before cleaning the outer door glass, let the door cool down completely. Clean the glass with an approved detergent and a soft cloth.

Internal door glass cleaning

Before cleaning the inner door glass, let the door cool down completely.

- 1) With the oven door closed, loosen the upper, middle, and lower screws on the door profiles as shown.

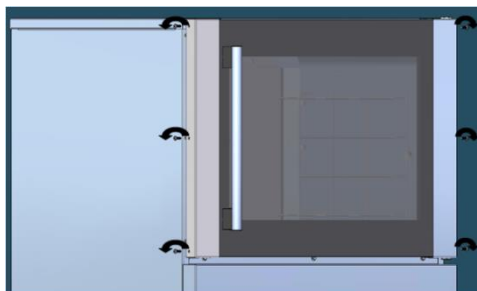

- 2) Using the handle, open the doors outer glass gently.

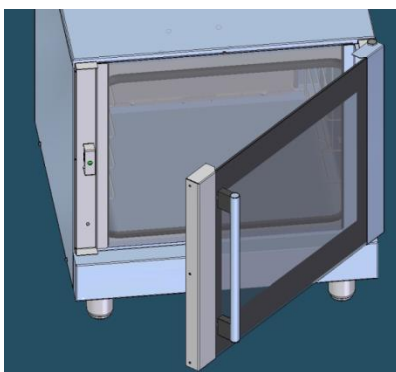

- 3) Clean the inner door glass with a mild detergent, warm water, and a soft cloth.
- 4) Carefully dry the glass surfaces with a dry soft cloth.
- 5) Gently close the outer door assembly using the handle and fasten the (6) screws taken out in step 1.

TROUBLESHOOTING

Type of fault	Cause of the fault	Corrective action
Control panel blank – No lights displayed on control board	Incorrect connection to the power mains.	Check connection to the mains
	Voltage not present in the mains.	Restore power supply voltage
	Temperature high-limit tripped	Reset the high-limit device
	Control board fuse (control panel) blown.	Contact Customer Service
Cooking cycle set and the  key activated: the oven does not run	Door open or ajar.	Close the door completely
	Door switch damaged.	Contact Customer Service
Select steam in program or push manual steam button but no steam is created	Incorrect connection to water mains	Check connection to the water mains (solenoid valve)
	Closed water valve	Check that the valve is open
	Damaged or dirty water inlet filter	Clean or replace the filter
	Damaged water inlet solenoid valve	Contact Customer Service
Water/Steam escaping from around door while closed	Incorrect gasket assembly or not installed correctly.	Check gasket assembly for flaws
	Damaged gasket	Contact Customer Service
	Loose hinge/handle assembly	Contact Customer Service
The oven does not cook evenly.	One of the fan motors is blocked or turns at low speed (in the event the oven has two motors).	Contact Customer Service
	The fan motors are not reversing direction	Contact Customer Service
	Resistor damaged or lost power	Contact Customer Service
Light in the cooking chamber does not work.	Damaged or expired light bulb	Replace the lamp.
	Light bulb is loose	Ensure the light is tight in socket
The display reads “ER1”	Cooking chamber probe - control board connection is interrupted.	Check connection to control board
	Damaged cooking chamber probe.	Contact Customer Service

6245 – Wiring Diagram

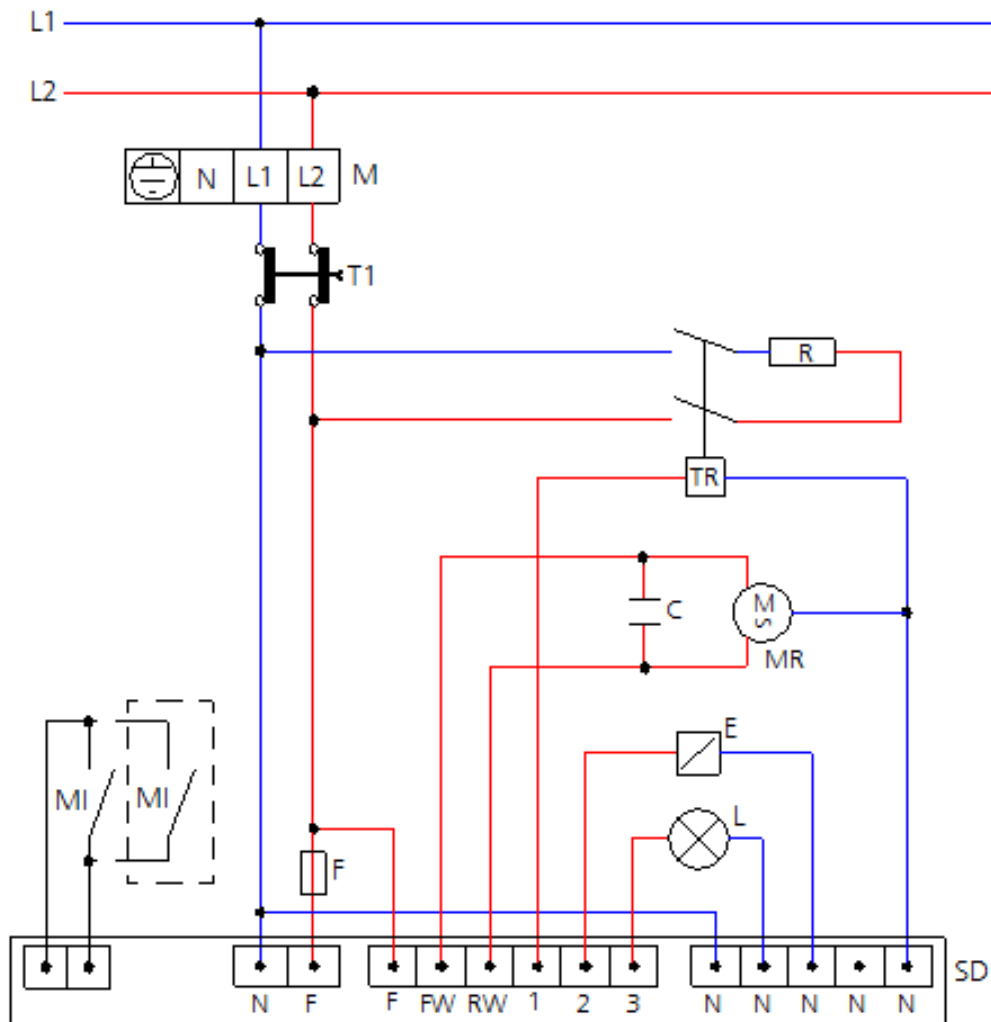

M	Power terminal board
SD	Control Board
T1	High-Limit Switch
F	Fuse
MI	Door Microswitch
TR	Contactor
L	Oven Light Bulb
C	Capacitors
MR	Fan Motor
E	Solenoid-Valve for Humidifier
R	Circular Heating-Element

6245 - EXPLODED DRAWINGS

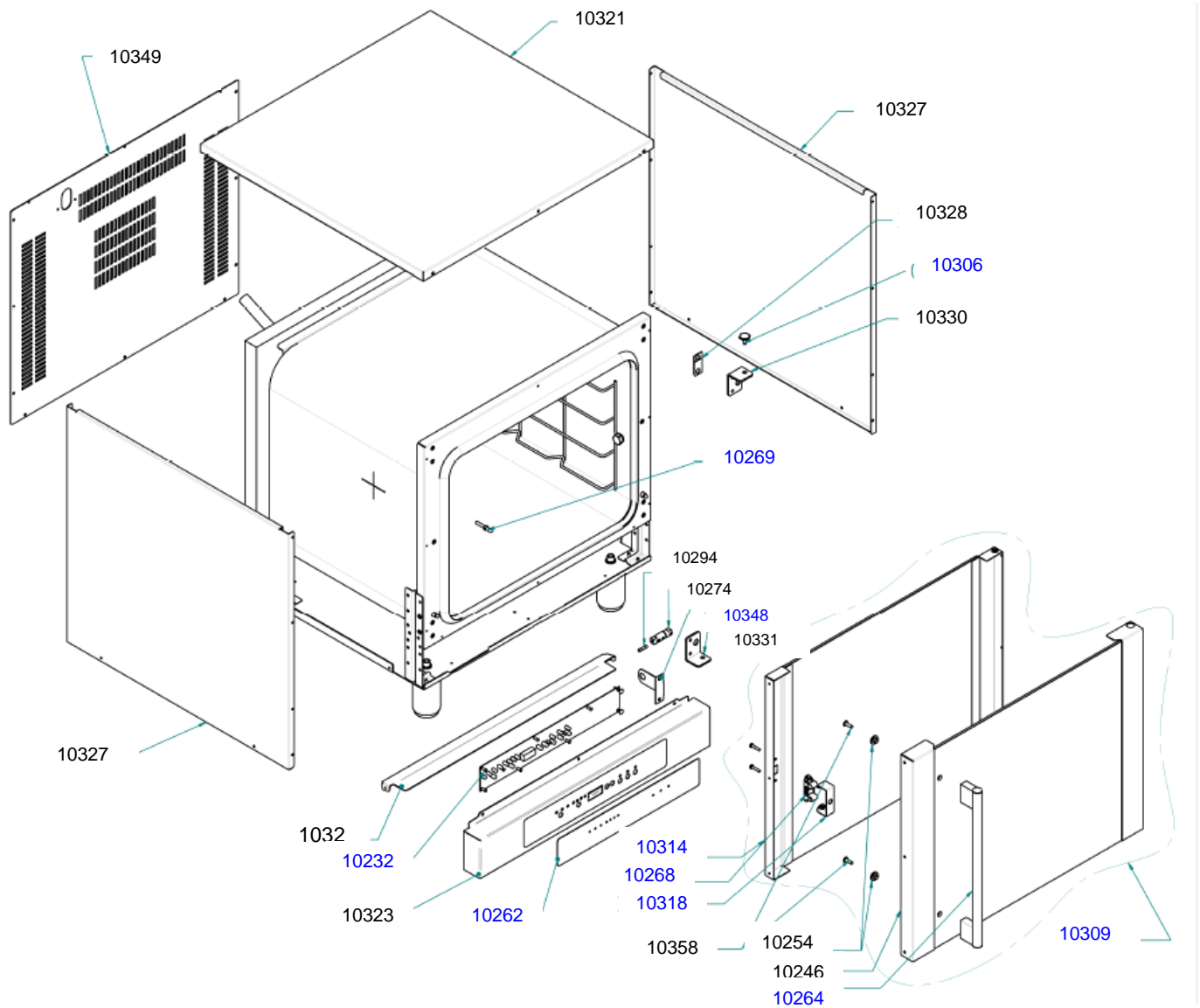

6245 - EXPLODED DRAWINGS

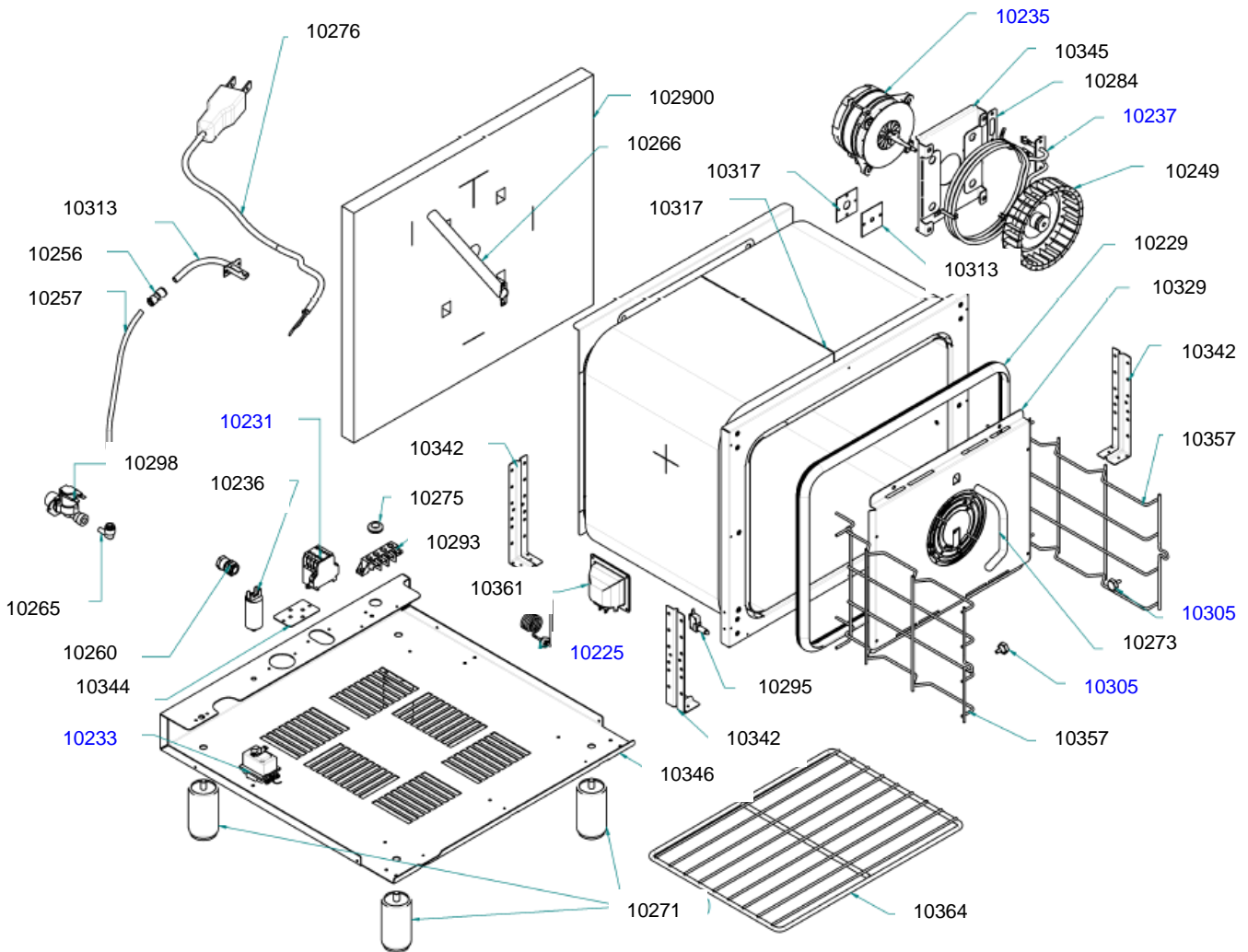

6245 – PARTS LIST

SERVICE PART #	PART DESCRIPTION
10249	30-BLADE FAN 160X40 MM
10225	PROBE PT100 FOR DIGITAL THERMOSTAT
10254	GLASS DOOR GLASS SPACER BUFFER
10256	PLASTIC INTERMEDIATE FITTING 10 - 8
10258	POLYETHYLENE PIPE LDPE 8X6
10265	ELBOW FITTING WITH TANG 8
10624	PIPE HANDLE D18 C/2 BLOCKS
10262	LABEL CONTROL
10361	COMPLETE LAMP HOLDER
10283	TEFLON MOTOR SHAFT SEAL GASKET
10284	CIRCULAR AND LOWER RESISTOR GASKET
10293	TERMINAL BOARD FV 173 V/V
10231	4-POLE CONTACTOR 230V-50//60Hz -20A
10232	ELECTRONIC BOARD SET-UP DIGITAL LINE CORE PROBE
10233	MANUAL RESET 3-POLE THERMOSTAT
10294	FUSE F 5X20 T 80 mA 250 V
10317	MOTOR SHAFT SEAL PLATE
10318	DOOR CLOSURE RATCHET FIXING PLATE
10235	SINGLE-PHASE REVERSING MOTOR P=120W
10345	MOTOR FIXING OMEGA
10346	BASE
10327	RH/LH SIDE
10321	COVER
10289	MUFFLE STRIP GLASS WOOL PANEL
10290	MUFFLE BOTTOM GLASS WOOL PANEL
10329	STAINLESS STEEL AIR COVER
10349	BACK
10298	SOLENOID VALVE - INLET 3/4 - OUTLET WITH "JG" FITTINGS
10236	5µF CAPACITOR
10313	LOAD PIPE SEALING ASSEMBLY + PLATE
10273	PIPE UD Ø14x1
10229	RECES. GASKET MUFFLE FRONT
10309	COMPLETE INSPECTION GLASS DOOR WITH STAINLESS STEEL PROFILES
10246	OUTER GLASS SILICONE SEALING ASSEMBLY + PROFILES
10314	INNER GLASS SILICONE SEALING ASSEMBLY + PROFILES
10330	UPPER HINGE
10331	LOWER HINGE
10271	FOOT H=100 MM
10305	18 MM NICKEL HEXAGONAL BRASS RATCHET
10274	FUSE HOLDER P3826M HTB-26M 20A 250 V
10276	POWER CABLE L=2000 MM WITH DIE-CAST PLUG 250V 15A
10266	CHIMNEY TO EXHAUST STEAM
10268	RATCHET ROLLER FOR DOOR CLOSURE
10269	PIN FOR DOOR CLOSURE
10275	GROMMET
10358	GALVANISED SCREW TE M5X16
10306	NICKEL HEXAGONAL BRASS RATCHET
10323	DASHBOARD
10328	HINGE PLATE SHIM
10344	PROGRAMMER FIXING PLATE
10348	BRACKET FIXING ELECTRONIC BOARD
10357	SIDE SUPPORT

PRODUCT WARRANTY

Except as otherwise provided below, Nemco Food Equipment, Ltd. ("Nemco") warrants, to the original user, its electrical/pneumatic products (other than blades and light bulbs) to be free of electrical and mechanical defects in material and workmanship under "normal use" (defined below) for the shorter of the following periods: (a) one (1) year from the date placed in service by the original user, or (b) 18 months from the date of shipment from its factory. Nemco also warrants its food preparation products (other than blades) to be free of mechanical defects in material and workmanship under normal use for two (2) years from the date placed in service by the original user. PaniniPro Sandwich Press to be free of electrical and mechanical defects in material and workmanship under "normal use" (defined below) for the following periods: (a) One (1) Year Labor, (b) Two (2) Year Parts. In addition, Nemco warrants its Global Solutions food preparation and electrical products (other than blades) to be free of mechanical defects in material and workmanship under normal use for one (1) year from the date placed in service by the original user. The warranty provided for herein shall be limited to parts and labor. Any determination that a product is defective or covered by this warranty, shall be made by Nemco, in its sole discretion. The determination of whether to repair or replace a defective, covered product, or to refund the purchase price for the product, will be at Nemco's sole discretion. This warranty does not cover products used outside the United States, or damages caused by accident, misuse, negligence of any person other than Nemco, current or voltage other than stated on the appliance, fire, flood or other casualty. Any alteration to the product or unauthorized repair voids this warranty. For purposes of this warranty, the phrase, "normal use" shall mean the use of the product in connection with food in accordance with the product manual accompanying the product.

Nemco shall be responsible only for repairs or replacements of defective parts performed by Nemco's authorized service personnel. Authorized service agencies are located in principal cities throughout the continental United States, Alaska and Hawaii.

THE FOREGOING WARRANTY IS EXCLUSIVE AND IN LIEU OF ALL OTHER WARRANTIES, EXPRESS OR IMPLIED. NEMCO EXPRESSLY DISCLAIMS ANY IMPLIED WARRANTY THAT ANY OF ITS PRODUCTS IS MERCHANTABLE, FIT FOR A PARTICULAR PURPOSE, OR DOES NOT INFRINGE ON THE RIGHTS OF ANY THIRD PARTY. THE FOREGOING WARRANTY SHALL BE NEMCO'S SOLE AND EXCLUSIVE OBLIGATION. ANY PERSON'S (BUYER, USER OR OTHERWISE) EXCLUSIVE REMEDY AGAINST NEMCO, AND NEMCO'S SOLE OBLIGATION, FOR ANY AND ALL CLAIMS, WHETHER FOR BREACH OF CONTRACT, WARRANTY, TORT (INCLUDING WITHOUT LIMITATION NEGLIGENCE), OR OTHERWISE, SHALL BE LIMITED TO NEMCO REPAIRING OR REPLACING THE PRODUCT, OR, AT NEMCO'S OPTION, REFUNDING THE PURCHASE PRICE THEREFOR. IN NO EVENT SHALL NEMCO HAVE ANY LIABILITY FOR DAMAGES IN AN AMOUNT EXCEEDING THE PURCHASE PRICE OF THE PRODUCT, NOR SHALL NEMCO HAVE ANY LIABILITY FOR INCIDENTAL, SPECIAL OR CONSEQUENTIAL DAMAGES. Any person desiring to make any claim against Nemco must do so within six (6) months after expiration of the applicable warranty period, or such claim shall be forever barred.

NOTE: WARRANTY DOES NOT COVER DAMAGE TO THE GRID, GRID COATING OR NONSTICK COATING. IT IS NEMCO'S SOLE DISCRETION TO DETERMINE IF A GRID, GRID COATING OR NONSTICK COATING CLAIM IS WARRANTED.

NOTE: WARRANTY DOES NOT COVER DAMAGE TO THE ROLLERS OR ROLLER COATING. IT IS NEMCO'S SOLE DISCRETION TO DETERMINE IF A ROLLER OR ROLLER COATING CLAIM IS WARRANTED.

NOTE: PLEASE REVIEW YOUR PRODUCT MANUAL FOR SPECIFIC WATER REQUIREMENTS. DISTILLED OR TREATED WATER MAY BE REQUIRED. PRODUCT FAILURE DUE TO SEDIMENT AND LIME BUILDUP IS NOT COVERED UNDER WARRANTY.

PRODUCT SERVICE

Nemco has a staffed service department, and we believe prompt service is extremely important to our customers. Therefore, we request all product service inquiries be handled in the following manner:

1. The end user should call Nemco Customer Service with the company name, address, phone number, model number, serial number (if applicable), Nemco Sales Order number or Dealer Purchase Order number and the nature of the problem (the "Claim Information").
2. The Nemco Customer Service Department will decide on the most appropriate course of action. If Nemco determines that it must inspect a product, the following procedure will be followed:

The end user will obtain a Return Goods Authorization number from Nemco Customer Service to return the product to Nemco for inspection. Please be sure to use this number on the box and on paperwork sent with the unit. Return the unit to Nemco. The Nemco Service Department will determine if the problem is covered by the foregoing warranty. If so, Nemco will repair the unit and return it to the end user. If the unit is determined not to be covered by the foregoing warranty, the dealer will be contacted to determine the next course of action. If the unit weighs less than 70 lbs., it will be considered a carry-in warranty. The service agent performing the service must call Nemco Customer Service to obtain a Service Authorization number and provide the Claim Information. If the unit weighs 70 lbs. or more, it will be considered an on-site warranty, and the service agent performing the service must call Nemco Customer Service to obtain a Service Authorization number and provide the Claim Information.

TERMS & CONDITIONS

- No merchandise shall be returned without prior written authorization.
- All returned merchandise must be unused, in original carton and shipped prepaid.
- All returned merchandise is subject to a 25% restocking charge.
- No returns will be accepted after 90 days of shipping date.
- Purchaser should make claim directly to carrier for any damages to merchandise that occur in transit.
- This Price List supersedes all previous price lists.
- Orders with an invoice value of \$2,100 net or more will be shipped freight prepaid to one destination in the continental United States.
- Terms are COD, CIA or Net 30 days with approved credit.
- Buyer shall pay all applicable federal, state and municipal sales or use tax.
- No minimum order charge.
- Prices subject to change without notification.

nemco® | FOOD
EQUIPMENT

Nemco	Global Solutions	Tecnoeka
6220-17	GS1105-17	EKFA 414 S (1700 W)
6220-28	GS1105-28	EKFA 312 S (1700 W)
6225-17	GS1110-17	EKFA 312 S2 (2800 W)
6225-28	GS1110-28	EKFA 412 S (1700 W)
6230	GS1115	EKFA 412 S2 (2800 W)
6235	GS1120	EKFA 312 M
6240	GS1130	EKFA 412 AL UD
6245	GS1125	EKFA 412 D AL UD

Approvals / Listings for Nemco Convection Ovens:

Our convection ovens are manufactured to Nemco Food Equipment Company specifications by Tecnoeka Srl, Italy.

All have ETL LISTED and ETL SANITATION LISTED approved by INTERTEK:

1) SAFETY: All units are approved to the **Commercial UL and CSA Standard** for use without a mechanical ventilation system **IF** local codes permit.

A representative sample of the listed devices have been tested, investigated and found to comply with the requirements of the Standard(s) for Commercial Electric Cooking Appliances (UL-197) and are identified with the ETL Listed Mark.

A representative sample of the listed devices have been tested, investigated and found to comply with the requirements of the Standard(s) for Commercial Cooking Appliance (CAN/CSA-C22.2 No. 109) and are identified with the cETL Listed Mark.

2) SANITATION: All units are approved to **NSF Standard**.

A representative sample of the listed devices have been tested, investigated and found to comply with the requirements of the Standard(s) for Commercial Cooking, Rethermalization and Powered Hot Food Holding and Transport Equipment (NSF-4) and are identified with the ETL Sanitation Listed Mark.

The above mentioned certifications are listed under the oven manufacturer, Tecnoeka Srl.