

B5BM Series

INSTALLATION INSTRUCTIONS

AIR HANDLER

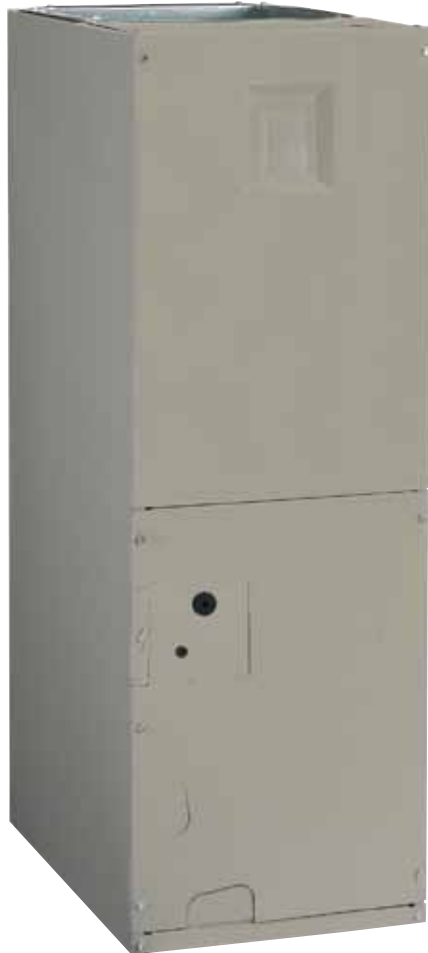

IMPORTANT

Please read all information in this manual thoroughly and become familiar with the capabilities and use of your appliance before attempting to operate or maintain this unit. These instructions are primarily intended to assist qualified individuals experienced in the proper installation of this appliance. Some local codes require licensed installation/service personnel for this type of equipment. Improper installation, service, adjustment, or maintenance may cause explosion, fire, electrical shock or other hazardous conditions which may result in personal injury or property damage.

Unless otherwise noted in these instructions, only factory authorized kits or accessories may be used with this product. Keep this manual where you have easy access to it in the future. If a problem occurs, check the instructions and follow recommendations given. If these suggestions don't eliminate your problem, call your servicing contractor.

**DO NOT DESTROY. PLEASE READ CAREFULLY AND
KEEP IN A SAFE PLACE FOR FUTURE REFERENCE.**

TABLE OF CONTENTS

Important Safety Information	3	Startup & Adjustments	12
Requirements & Codes	3	Before You Start the Unit	12
General Information	4	Refrigerant Charging	13
Before You Install this Unit	4	Air Circulation	13
Locating the Air Handler	4	Running the Blower Continuously	13
Minimum Clearances	4	Continuous Low Speed Fan Operation	13
Operation of Air Handler During Construction	4	Turning the Blower Off	13
Installation in a Garage	5	System Cooling	13
Plenums & Air Ducts	5	System Heating	13
Unconditioned Spaces	5	Blower Configurations	13
Air Filters	5	Determining Nominal System Capacity	13
Acoustical Duct Work	5	3-Speed Units	13
Air Handler Installation	6	Unit Maintenance	14
Packaging Removal	6	Troubleshooting	14
Mounting Applications	6	Figures & Tables	15
Upflow Installations	6	Figure 10. B5 Series Physical Dimensions	15
Downflow Installations	6	Figure 11. Air Handler Components	16
Horizontal Installations	6	Airflow Data	17
Horizontal Left Installations	7	Table 2. B5BM Air Handlers	17
Horizontal Right Installations	7	Electrical Diagrams	18
Refrigerant Line Connections	8	Figure 12. Typical T-Stat Connections	18
Orifice removal & Installation	8	Figure 13. Fixed Speed Control Board	19
Connecting the Linesets	9	Figure 14. B5BM W.D. Variable Speed	20
Condensate Drainage	10	Figure 15. B5BM W.D. with X13 Motor	21
Electrical Connections	11	Figure 16. B5BM W.D. 8 & 10 kW	22
Pre-Electrical Checklist	11	Figure 17. B5BM W.D. 8 & 10 kW (X13 Motor)	23
Line Voltage	11	Figure 18. B5BM W.D. 15 kW	24
Grounding	11	Figure 19. B5BM W.D. 20 kW	25
Thermostat / Low Voltage Connections	11	Electrical Data	26
Control Board	12	Table 3. B5BM MCA & MOP Data	26
Twinning	12	Table 4. Control Board Operation	26
Heater Kits	12	Installation / Performance Checklist	28

IMPORTANT SAFETY INFORMATION

INSTALLER: Please read all instructions before servicing this equipment. Pay attention to all safety warnings and any other special notes highlighted in the manual. Safety markings are used frequently throughout this manual to designate a degree or level of seriousness and should not be ignored. **WARNING** indicates a potentially hazardous situation that if not avoided, could result in personal injury or death. **CAUTION** indicates a potentially hazardous situation that if not avoided, may result in minor or moderate injury or property damage.

WARNING:

ELECTRICAL SHOCK, FIRE OR EXPLOSION HAZARD

Failure to follow safety warnings exactly could result in serious injury or property damage.

Improper servicing could result in dangerous operation, serious injury, death or property damage.

- **Before servicing, disconnect all electrical power to air handler.**
 - **When servicing controls, label all wires prior to disconnecting. Reconnect wires correctly.**
 - **Verify proper operation after servicing.**
-

WARNING:

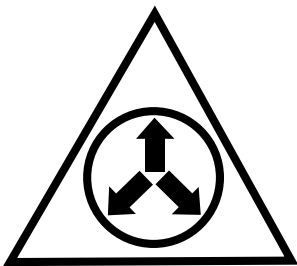

NITROGEN	
HEALTH	1
FLAMMABILITY	0
REACTIVITY	0

0 Minimal Hazard 1 Slight Hazard

B5 Series Air Handlers leave the factory with a nitrogen holding charge. Use caution when preparing coils for field connections. If repairs make it necessary for evacuation and charging, it should only be attempted by qualified, trained personnel thoroughly familiar with this equipment. Some local codes require licensed installation service personnel to service this type of equipment. Under no circumstances should the equipment owner attempt to install and/or service this equipment. Failure to comply with this warning could result in equipment damage, personal injury, or death.

REQUIREMENTS & CODES

WARNING:

This unit must be installed in accordance with instructions outlined in this manual during the installation, service, and operation of this unit. Unqualified individuals should not attempt to interpret these instructions or install this equipment. Failure to follow safety recommendations could result in possible damage to the equipment, serious personal injury or death.

- The installer must comply with all local codes and regulations which govern the installation of this type of equipment. Local codes and regulations take precedence over any recommendations contained in these instructions. Consult local building codes for special installation requirements.
- This equipment contains nitrogen gas. Installation or servicing should only be performed by qualified trained personnel thoroughly familiar with this type equipment.
- All electrical wiring must be completed in accordance with local, state and national codes and regulations and with the National Electric Code (ANSI/NFPA 70) or in Canada the Canadian Electric Code Part 1 CSA C.22.1.
- Installation of equipment may require brazing operations. Installer must comply with safety codes and wear appropriate safety equipment (safety glasses, work gloves, fire extinguisher, etc.) when performing brazing operations.
- When connecting refrigerant linesets together, it is recommended that dry nitrogen be flowing through the joints during brazing to prevent internal oxidation and scaling.
- Install this unit only in a location and position as specified on pages 4 & 5. This unit should be located with consideration of minimizing the length of the supply and return ducts. See Table 2 (page 17) and the rating plate for proper circulating airflow data.
- Follow all precautions in the literature, on tags, and on labels provided with the equipment. Read and thoroughly understand the instructions provided with the equipment prior to performing the installation and operational checkout of the equipment.
- This air handler may be used for temporary heating of buildings or structures under construction. See the guidelines listed on page 4.
- Air handler installations in a residential garage must be installed as specified on page 5.

GENERAL INFORMATION

This appliance has been tested for capacity and efficiency in accordance with AHRI Standards and will provide many years of safe and dependable comfort, providing it is properly installed and maintained. Abuse, improper use, and/or improper maintenance can shorten the life of the appliance and create unsafe hazards. Please read all instructions before installing the unit.

Before You Install this Unit

- √ This equipment is securely packaged at the time of shipment and upon arrival should be carefully inspected for damage prior to installing the equipment at the job site. Claims for damage (apparent or concealed) should be filed immediately with the carrier.
- √ The cooling load of the area to be conditioned must be calculated and a system of the proper capacity selected. It is recommended that the area to be conditioned be completely insulated and vapor sealed.
- √ Check the electrical supply and verify the power supply is adequate for unit operation. The system must be wired and provided with circuit protection in accordance with local building codes. If there is any question concerning the power supply, contact the local power company.
- √ Verify the static pressure drop of the coil, filter, and duct work do not exceed the air delivery specs of the air handler.

Locating the Air Handler

- Survey the job site to determine the best location for mounting the unit. Consideration should be given to availability of electric power, service access, and noise.
- The dimensions of the room or alcove must be able to accommodate the overall size of the unit and the installation clearances listed in Figure 1. Physical dimensions for this air handler are also shown in Figure 11 (page 16).
- The air handler should be installed before routing the refrigerant tubing.

Minimum Clearances

- This appliance must be installed in accordance with clearances listed in Figure 1. The air handler must be installed with ample clearance for easy access to the air filter, blower assembly, heater assembly, controls, and vent connections.
- Sufficient clearance for unobstructed airflow through a louvered door must be maintained in order to achieve rated performance.

Operation of Air Handler During Construction

CAUTION:

Failure to follow these instructions will void the factory warranty and may significantly reduce the life or the performance of the air handler, and/or result in other unsafe conditions. It is the responsibility of the installing contractor to insure these provisions are met.

Operating an air handler in a construction environment can cause the appliance a variety of problems. Proper use of commercial portable space heating equipment during construction is recommended. This air handler may be used during construction if it is not in violation of any applicable codes and the following criteria are met:

- The installation must meet all applicable codes and be permanently installed according to the instructions supplied with the air handler. This includes electrical supply, gas supply, and duct work.
- The air handler must be controlled by a properly installed thermostat that complies with the current provisions of the NEC (ANSI/NFPA 70) and all applicable codes having jurisdiction. Thermostat connections must be made in accordance with instructions supplied with the air handler and thermostat. See pages 11 - 12.
- The installation must include a properly installed filter in the return air system with no by-pass air. The filter must be inspected frequently and replaced when necessary.
- Return air must be supplied unrestricted and located such that dust and gases from construction activity are not introduced into the circulating air system.
- Before occupying the structure: The filter must be replaced or cleaned, the duct work must be inspected and cleaned of any construction debris, and the air

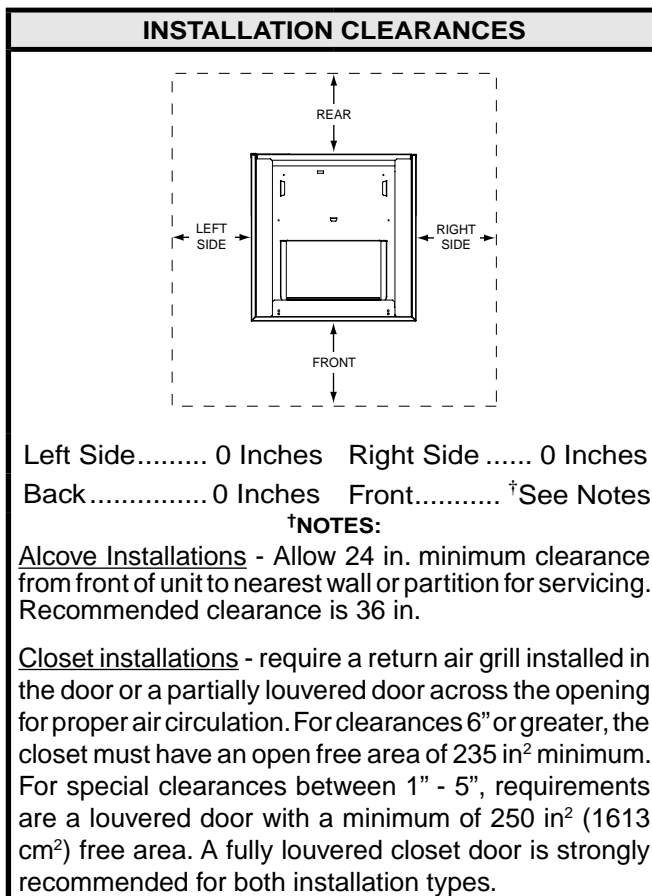

Figure 1. Minimum Unit Clearances

- handler must be cleaned and/or repaired if found to be dirty, damaged, or malfunctioning in any way by a qualified HVAC technician. The air handler shall be inspected and approved by applicable local authority even if this requires redundant inspections.
- The serial number for the air handler used during construction must be submitted in writing (fax and email also acceptable). This information will be used to track the long-term affects of air handler usage during construction. Proof of this submittal shall be available for the final inspection of the air handler prior to occupancy.

Installation in a Garage

WARNING:

Do not place combustible materials on or against the cabinet. Do not place flammable materials, (gasoline, paint thinners, etc.) or any other flammable vapors and liquids, in the vicinity of the air handler.

The B5 Series air handler may be installed in a residential garage with the provision that the unit must be located or protected to prevent physical damage by vehicles.

Plenums & Air Ducts

- Plenums and air ducts should be installed in accordance with the standards of the National Fire Protection Association Standard for Installation of Air Conditioning Systems (NFPA 90A), Standard for Installation of Residence Type Warm Air Heating and Air Conditioning Systems (NFPA 90B), and all applicable local codes. NFPA publications are available by writing to: National Fire Protection Association, Batterymarch Park, Quincy, ME 02269 or visit www.NFPA.org online.

WARNING:

All return ducts must be secured to the air handler using appropriate methods. All return ducts must be adequately sealed. When return air is provided through the bottom of the unit, the joint between the air handler and the return air plenum must be air tight.

Return air and circulating air ducts must not be connected to any other heat producing device such as a fireplace insert, stove, etc. This may result in fire, explosion, carbon monoxide poisoning, personal injury, or property damage.

- Design the duct work according to methods described by the Air Conditioning Contractors of America (ACCA).
- This unit is designed only for use with a return and supply duct. The return air duct must have the same free area

as the opening provided on the blower coil unit. The ducts should be appropriately sized to the capacity of the air handler to ensure its proper airflow rating.

- Use transition fittings if the supply and/or return air openings of the unit do not match the duct openings. These transitions should be dimensioned in accordance with standard practice as specified in the ASHRAE recommendations for duct transitions.
- Flexible connectors should be used between the unit and the ductwork to prevent transmission of vibration from the unit to the structure. If electric heater kits are installed, heat resistant material must be used for the flexible connector at the supply air end of the unit.
- Seal all connections and joints with industrial grade sealing tape or liquid sealant. Requirements for sealing ducts vary from region to region. Consult with local codes for requirements specific to your area.

Unconditioned Spaces

All duct work passing through unconditioned space must be properly insulated to minimize duct losses and prevent condensation. Use insulation with an outer vapor barrier. Refer to local codes for insulation material requirements.

Air Filters

B5 Series Air Handlers are not supplied with an air filter when shipped from the factory. The installer must provide a high velocity filter that is appropriately sized to the return air duct opening or filter rack located in the bottom of the unit. Accessing the filter does not require tools and can be removed from the front of the unit by removing the filter door. See Unit Maintenance (page 14) for filter sizes and other important information.

WARNING:

Never operate the air handler without a filter or with doors removed. Dust and lint can build up on internal components, resulting in loss of efficiency, equipment damage, and possible fire.

Acoustical Duct Work

- Certain installations may require the use of acoustical lining inside the supply duct work. Acoustical insulation must be in accordance with the current revision of the Sheet Metal and Air Conditioning Contractors National Association (SMACNA) application standard for duct liners. Duct lining must be UL classified batts or blankets with a fire hazard classification of FHC-25/50 or less.
- Fiber duct work may be used in place of internal duct liners if the fiber duct work is in accordance with the current revision of the SMACNA construction standard on fibrous glass ducts. Fibrous duct work and internal acoustical lining must be NFPA Class 1 air ducts when tested per UL Standard 181 for Class 1 ducts.
- Damping ducts, flexible vibration isolators, or pleated media-style filters on the return air inlet of the air handler may be used to reduce the transmission of

equipment noise emanating from the air handler. These treatments can produce a quieter installation, particularly in the heated space. However, they can increase the pressure drop in the duct system. Care must be taken to maintain the proper maximum pressure rise across the air handler, temperature rise and flow rate. This may mean increasing the duct size and/or reducing the blower speed. These treatments must be constructed and installed in accordance with NFPA and SMACNA construction standards. Consult with local codes for special requirements. For best sound performance, be sure to install all the needed gaskets and grommets around penetrations into the air handler, such as for electrical wiring.

AIR HANDLER INSTALLATION

The B5 Series Air Handler is shipped ready for vertical upflow installation and is approved for attic, basement, alcove / closet or crawlspace installation with zero clearance to combustibles. See Figure 1 (page 4) for required installation clearances. **This appliance is only for indoor use.**

- The unit must be leveled at installation and attached to a properly installed duct system.
- The surface that the air handler is mounted on must provide sound physical support of the unit.
- The air handler must be installed so that all electrical components are protected from water.
- If a louvered door is installed across the front of this unit, the appliance must be mounted flush or behind front edge of finished wall.

Packaging Removal

Remove the shipping crate and User’s Manual from the equipment. When removing the crate, use extra care so that tubing connections are not damaged.

Mounting Applications

This air handler may be applied in an upflow or horizontal (left / right discharge) application. These units may also be applied in downflow discharge when applied with the appropriate field kit as specified in the units Technical Specifications.

Through-the-floor installations require a 1/4” thick noncombustible resilient gasket to be used whenever the supply or return air ducts pass through the floor. The gasket should be positioned between the duct, unit, and floor.

Upflow Installations

All air handlers are factory shipped, ready for upflow installation. The horizontal drain pan should be removed from the air handler when installing the unit in an upflow configuration. All return air must enter from the bottom of the unit. A typical upflow unit is shown in Figure 2.

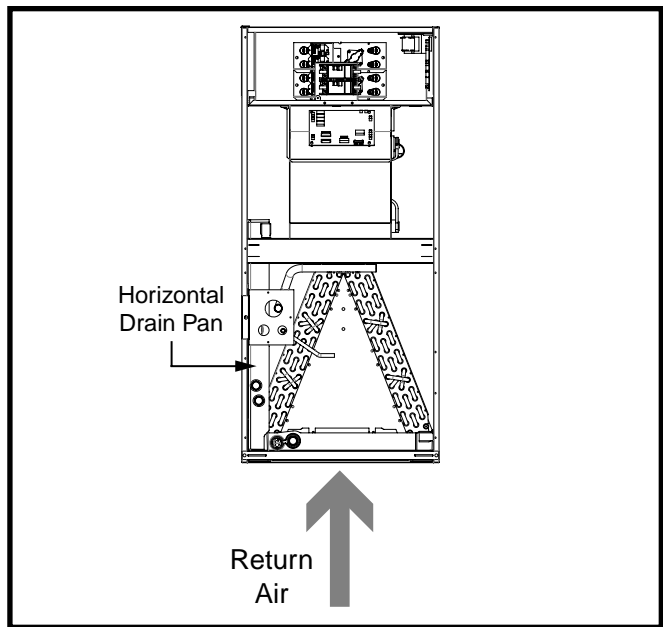

Figure 2. Upflow Installation

Downflow Installations

The downflow accessory kit (See Technical Specifications) is required for downflow applications. Instructions for installing the downflow accessory kit are included with the kit. It is recommended that the accessory be installed prior to installing the unit. All return air in downflow applications must enter through the top of the unit. A typical installation of the unit in a downflow application is shown in Figure 3.

Horizontal Installations

The B5 Series air handler can be installed horizontally in an attic, basement, crawl space or alcove. It can also be suspended from a ceiling in a basement or utility room in either a right to left airflow or left to right airflow as shown in Figure 4 (page 7). Air handlers may or may not be shipped

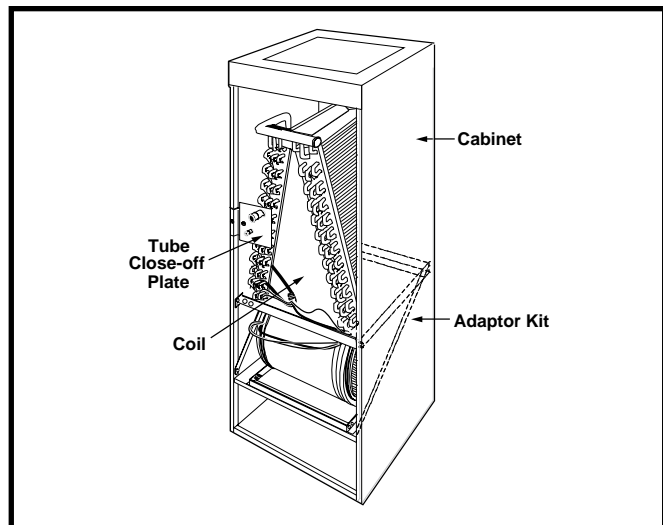

Figure 3. Downflow Installation

from the factory with all the parts required for horizontal left applications and horizontal right applications. If your unit does not have parts for a horizontal application, a kit is available.

NOTE: In all horizontal applications in which the unit is installed above a finished ceiling and/or living space, a secondary drain pan must be installed under the entire unit to avoid damage to the ceiling in the event of condensate overflow. Additionally, it is recommended that an approved water level indicator or float switch device be used to shut down the unit in the event water is detected in the auxiliary drain pan.

If suspending the air handler from the ceiling, assemble a support frame (Figure 5) using slotted iron channel and full threaded rod. Fasten the frame together with nuts, washers, and lockwashers. Secure the support frame to the rafters with lag bolts. The air handler can also be suspended using steel straps around each end of the unit. The straps should be attached to the air handler with sheet metal screws and to the rafters with bolts.

Horizontal Left Installations:

1. Remove the coil access door.
2. Remove the plug from one of the threaded holes in the horizontal drain pan. Completely remove the webbing located in the threaded holes of the horizontal drain pan. **IMPORTANT:** If the webbing is not removed, the condensate will not drain properly and ceiling damage may occur.
3. Insert the plug (from horizontal drain pan) into the open and unused drain hole in the drain pan at the bottom of the unit to block bypass air.
4. Remove the corresponding drain line knockout from the coil access door to allow access to the horizontal drain.
5. Replace the door and attach the drain line.

Horizontal Right Installations:

1. Remove the coil access door. Unscrew the line-set tube close-off plate from the front left cabinet rail.
2. Slide the coil and drain pan assembly out of the unit.
3. Remove the sheet metal hairpin covers (if supplied) from the back of the coil and discard.
4. Place the horizontal drain pan on the opposite side of the coil. On units with 2 sets of knockouts, remove the other set of knockouts in the coil spacing plates and insert support rod.
5. Slide the coil and the horizontal drain pan assembly back into the unit. Re-attach the tube close off plate.
6. Remove the plug from one of the threaded holes in the horizontal drain pan. Completely remove the webbing located in the threaded holes of the drain pan. **IMPORTANT:** If the webbing is not removed, the condensate will not drain properly and ceiling damage may occur.
7. Insert the plug (from horizontal drain pan) into the open and unused drain hole in the drain pan at the bottom of the unit to block bypass air.
8. Remove the corresponding drain line knockout from the coil access door to allow access to the horizontal drain.
9. Replace the door and attach the drain line.

The unit may also be installed in a horizontal application with the unit suspended from the ceiling. A typical installation of the unit in a suspended horizontal application is shown in Figure 5.

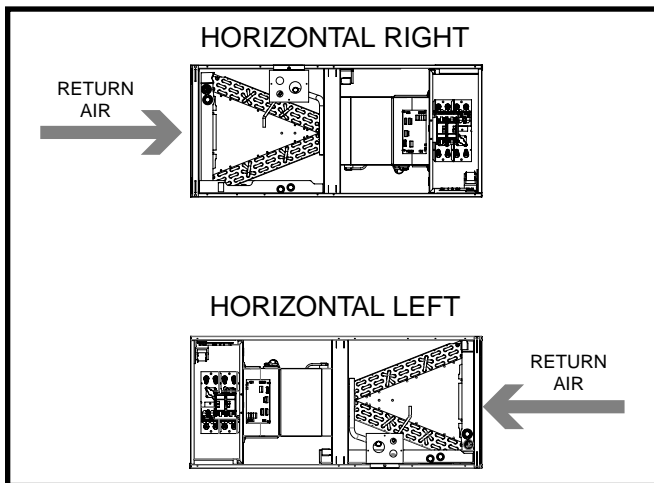

Figure 4. Horizontal Configurations

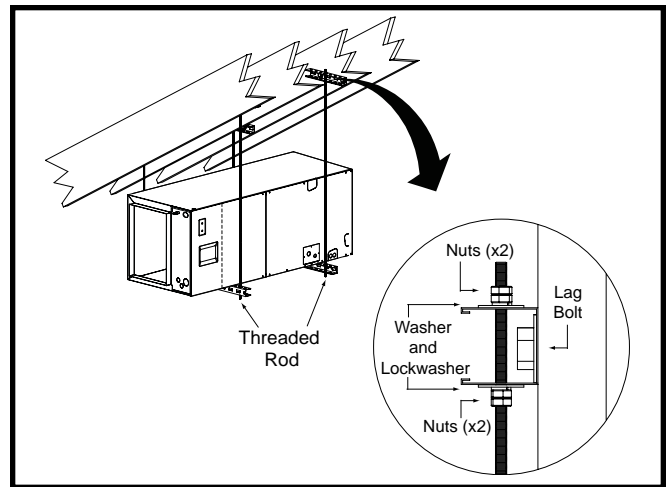
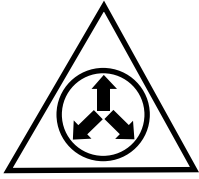

Figure 5. Unit Horizontally Suspended

⚠ WARNING:



NITROGEN	
HEALTH	1
FLAMMABILITY	0
REACTIVITY	0
0 Minimal Hazard 1 Slight Hazard	

The coil in the air handler is factory shipped with a nitrogen charge. Avoid direct face exposure or contact with valve when gas is escaping. Always ensure adequate ventilation is present during the depressurization process. Address any uncertainties before proceeding. Failure to comply with this warning could result in equipment damage, personal injury, or death.

⚠ CAUTION:

Before charging, refer to the units rating label for proper refrigerant information. Only use refrigerant specified on the rating label. Use of another refrigerant will damage the unit.

- The installer should make every effort to ensure the field installed refrigerant containing components of the system have been installed in accordance with these instructions and sound installation practices for reliable system operation and longevity.
- The air handler coil does not contain a refrigerant charge. Refer to the installation instructions supplied with the outdoor unit for refrigerant charge information.
- Always refer to the installation instructions supplied with the outdoor unit for piping requirements. The suction and liquid lines must be sized in accordance with the condensing unit specifications. See Figure 11 (page 16) for liquid and suction line locations.
- When connecting refrigerant linesets together, it is recommended that dry nitrogen be flowing through the joints during brazing. This will prevent internal oxidation and scaling from occurring.
- Refrigerant tubing should be routed in a manner that minimizes the length of tubing and the number of bends in the tubing. It should be supported in a manner that prevents it from vibrating or abrading during system operation. Tubing should be kept clean of foreign debris during installation.
- If precise forming of refrigerant lines is required, a copper tubing bender is recommended. Avoid sharp bends and contact of the refrigerant lines with metal surfaces.
- Refrigerant lines should be wrapped with pressure sensitive neoprene or other suitable material where they pass against sharp sheet metal edges.

⚠ CAUTION:

Before brazing the air handler, remove the core from the service port. Failure to comply may result in leakage at the service valve. Replace the core and cap once brazing is complete.

Orifice Removal & Installation

⚠ WARNING:

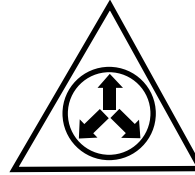

NITROGEN	
HEALTH	1
FLAMMABILITY	0
REACTIVITY	0
0 Minimal Hazard 1 Slight Hazard	

This coil is pressurized with Nitrogen. Pressure must be relieved in order to prevent the potential of an injury or fatality from the cap during the removal process. Avoid direct face exposure or contact with valve when gas is escaping. Always ensure adequate ventilation is present during the depressurization process. Any uncertainties should be addressed before proceeding.

The orifice installed in the air handler has been sized for use with the most popularly matched outdoor units. The orifice size as shipped from the factory is listed on the air handler rating plate. Perform steps 1 - 9 to confirm that the orifice size meets the requirements outlined in the outdoor unit installation manual.

1. Remove the cap from the end of the liquid line.
 2. Verify pressurization by depressing the Schrader valve on the end of the liquid line. Listen for any escaping gas. If there is no pressure, test the coil for leakage.
 - If leakage is found, clearly mark the location of the leak and return the coil to the distributor for processing.
 - If no leaks are found, the coil may be installed.
 3. Depress the valve to relieve all pressure from the coil.
 4. Remove and discard the valve core.
-

⚠ CAUTION:

To prevent damage to the unit or internal components, it is recommended that two wrenches be used when loosening or tightening nuts. Do not over tighten!

5. Using two wrenches, loosen the nut and distributor body as shown in Figure 6 (page 9). Turn the assembly nut counter-clock-wise until the orifice body halves are separated.

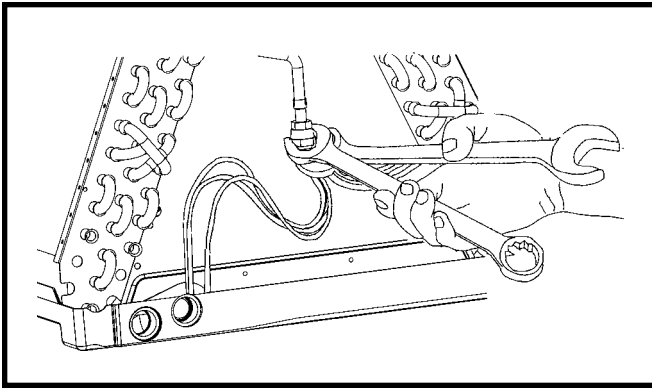

Figure 6. Loosening of Nut & Distributor Body

6. Insert a light-gauge wire hook between the distributor body and the restrictor orifice while being careful not to scratch either part. Carefully remove the restrictor orifice from the distributor body. See Figure 7.

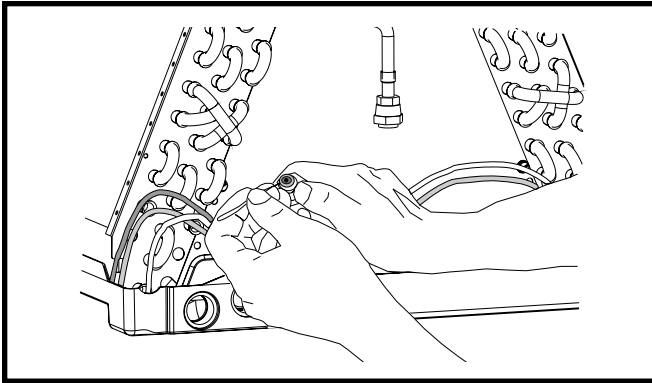

Figure 7. Removal of Orifice

7. Check the actual size of the new orifice. **NOTE:** The size is stamped on its side. Do not use pin gauges to measure the orifice diameter.
8. Insert the new orifice into the distributor body, rounded end down. See Figure 8.

⚠ CAUTION:

To prevent damage to the unit or internal components, it is recommended that two wrenches be used when loosening or tightening nuts. Do not over tighten!

9. Realign the assembly nut on the distributor body and hand tighten both components. Mark a line on both bodies and then tighten an additional 1/4 turn using two wrenches. The movement of the two lines will show how much the nut is tightened. If a torque wrench is used, tighten to 10-12 ft. lbs. or 14-16 Nm.

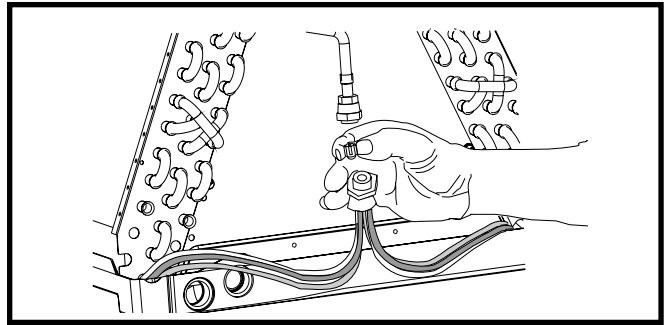

Figure 8. Restrictor Insertion into Distributor Body

Connecting the Linesets

IMPORTANT NOTES FOR HORIZONTAL OR DOWNFLOW INSTALLATIONS WITH TXV VALVE:

- The sensing bulb must be located flush against the suction line for optimum heat transfer.
- Avoid attaching the sensing bulb to the lowest part of the suction line where condensate may accumulate.
- Do not locate the sensing bulb on vertical sections of the lineset.
- For horizontal lines, the bulb should not be located at 12 or 6 o'clock position of the suction line. The best location is at 4 or 8 o'clock.
- For additional information on proper sensing bulb locations, please refer to the valve manufacturer's instructions.

IMPORTANT: The Orifice Removal & Installation steps on page 8 must be performed before the linesets are connected.

1. Remove grommets from line set holes.

⚠ CAUTION:

It is recommended that a wet rag be wrapped around the suction line in front of the close off plate or the sensing bulb (if TXV is installed) before applying heat. Failure to keep components cool during brazing may result in structural damage, premature equipment failure, or possible personal injury.

2. Remove the rubber plug on the suction line.
3. Route and cut both lineset tubes to proper length in accordance with the outdoor unit specifications. Verify the ends are round, clean, and free of any burrs.
4. Position grommet on line set with sufficient distance away from brazing area. Brazing processes can permanently damage grommets.
5. Connect the suction and liquid lineset tubes.

⚠ CAUTION:

It is recommended that a wet rag be wrapped around the suction line in front of the close off plate or the sensing bulb (if TXV is installed) before applying heat. Failure to keep components cool during brazing may result in structural damage, premature equipment failure, or possible personal injury.

6. Braze the individual connections with dry nitrogen flowing through the joints. **NOTE:** This will prevent internal oxidation and scaling from occurring.
7. Wrap the refrigerant lines with pressure sensitive neoprene or other suitable material especially where the lines enter the opening in the sheet metal.
8. Evacuate the system of moisture and non-condensables to prevent low efficiency operation or damage to the unit. The suggested range of evacuation is 250 - 500 microns.
9. Charge the system with refrigerant. Refer to the outdoor unit installation manual for additional charging instructions.
10. Check the system for leaks, including the lineset and the brazed joints. **NOTE:** Apply a soap and water solution on each joint or union with a small paintbrush. If bubbling is observed, the connection is not adequately sealed.
11. Replace all grommets and properly dispose of all removed parts.

Condensate Drainage

⚠ CAUTION:

The air handler must be level to ensure proper condensate drainage. An unlevel installation may result in structural damage, premature equipment failure, or possible personal injury.

- Methods for disposing of condensate vary according to local codes. Refer to local codes or authority having jurisdiction for restrictions and proper condensate disposal requirements.
- The drain pan that is supplied with this air handler contains a primary and secondary drain fitting. The condensate is drained from the unit through two 3/4" female pipe fittings located on the front side of the unit as shown in Figure 9.
- The drain pan **MUST** be drained with field supplied tubing and looped to form a 5" trap. Both drain tubes must have a minimum diameter of 3/4" and be trapped separately. **IMPORTANT:** Failure to install a trap may result in condensation overflowing the drain pan, resulting in substantial water damage to surrounding area.

- Route both lines to a suitable drain, avoiding sharp bends and pinching of the lines. The drain should maintain a minimum horizontal slope in the direction of discharge of not less than 1" vertical for every 10 ft of horizontal run.
- If the air handler is located in or above a living space where damage may result from condensate overflow, an auxiliary drain pan shall be installed under the unit. A separate drain line should extend from the pan to a conspicuous point and serve as an alarm indicating that the primary drain is restricted. As an alternative to a separate drain line, an approved water level indicator or float switch device should be used to shut down the unit in the event water is detected in the auxiliary pan.
- Install a single 5 inch trap in the condensate drain line as close to the coil as possible. Make sure that the top of the trap is below the bottom of the drain pan to prevent the condensate from overflowing the drain pan. **NOTE:** There must be only one trap in the drain line. Using more than one trap may prevent drainage.
- Prime the trap with water. Insulate the drain if it is located in an unconditioned space, and test the condensate line for leaks. Consult local codes for additional restrictions or precautions.
- During system checkout, inspect the drain line and connections to verify proper condensate drainage.

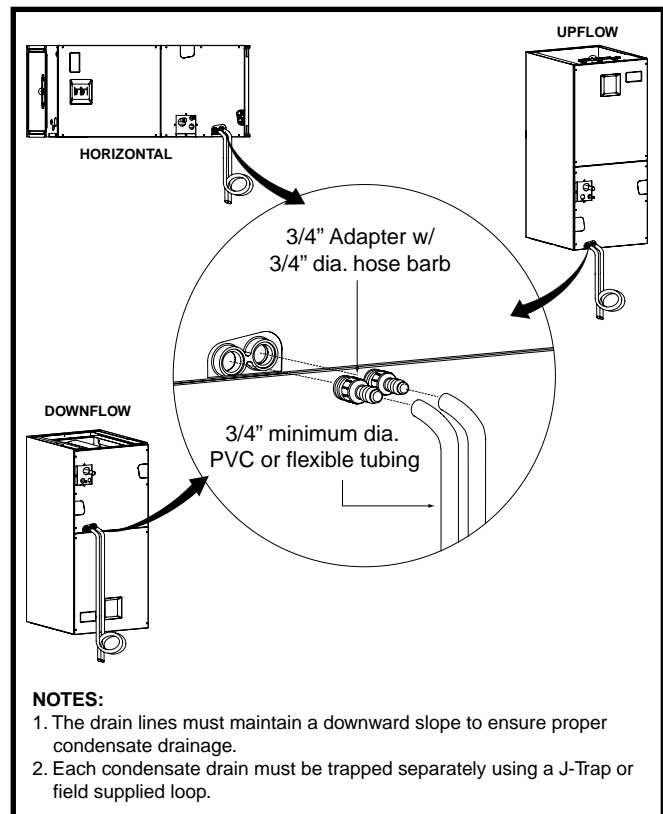

Figure 9. Condensate Drainage

ELECTRICAL CONNECTIONS

WARNING:

ELECTRICAL SHOCK, FIRE OR EXPLOSION HAZARD

Failure to follow safety warnings exactly could result in serious injury or property damage.

Improper servicing could result in dangerous operation, serious injury, death or property damage.

- **Before servicing, disconnect all electrical power to the air handler.**
 - **When servicing controls, label all wires prior to disconnecting. Reconnect wires correctly.**
 - **Verify proper operation after servicing.**
-

- Electrical connections must be in compliance with all applicable local codes and ordinances, and with the current revision of the National Electric Code (ANSI/NFPA 70).
- For Canadian installations, the electrical connections and grounding shall comply with the current Canadian Electrical Code (CSA C22.1 and/or local codes).

Pre-Electrical Checklist:

- ✓ Verify the voltage, frequency, and phase of the supply source match the specifications on the unit rating plate.
- ✓ Verify that the service provided by the utility is sufficient to handle the additional load imposed by this equipment. See the unit wiring label or Table 3 (page 26) for proper high and low voltage wiring.
- ✓ Verify factory wiring is in accordance with the unit wiring diagram (Figures 14 - 19, pages 20 - 25). Verify none of the connections loosened during shipping or installation.

Line Voltage

- **An electrical disconnect must be located within sight of and readily accessible to the unit.** This switch shall be capable of electrically de-energizing the outdoor unit. See unit data label for proper incoming field wiring. Any other wiring methods must be acceptable to authority having jurisdiction.
- It is recommended that the line voltage to the unit be supplied from a dedicated branch circuit containing the correct fuse or circuit breaker for the unit.
- Overcurrent protection must be provided at the branch circuit distribution panel and sized as shown on the unit rating label and according to applicable local codes. See the unit rating plate and Table 3 (page 26) for maximum circuit ampacity and maximum overcurrent protection limits.
- The installer should become familiar with the wiring diagram/schematic before making any electrical connections to the unit.

- Use only copper wire for the line voltage power supply to this unit. Use proper code agency listed conduit and a conduit connector for connecting the supply wires to the unit. Aluminum supply wire may be used if a heater kit is installed.
- If replacing any of the original wires supplied with the unit, the replacement wire must be copper wire consisting of the same gauge and temperature rating.
- Provide power supply for the unit in accordance with the unit wiring diagram, and the unit rating plate. Use UL listed conduit and conduit connectors for connecting the supply wires to the unit and for proper grounding. Field supplied bushings for the power supply cables must be added to support and protect the power supply cables.
- All 208/230 Volt units are shipped from the factory wired for 240 volt operation. For 208V operation, remove the lead from the transformer terminal marked 240V and connect it to the terminal marked 208V.

Grounding

WARNING:

The unit cabinet must have an uninterrupted or unbroken electrical ground to minimize personal injury if an electrical fault should occur. Do not use gas piping as an electrical ground!

This unit must be electrically grounded in accordance with local codes or, in the absence of local codes, with the National Electrical Code (ANSI/NFPA 70) or the CSA C22.1 Electrical Code. Use the grounding lug provided in the control box for grounding the unit.

Thermostat / Low Voltage Connections

- Thermostat connections shall be in accordance with the instructions supplied with the thermostat and the indoor equipment. The low voltage wires must be properly connected to the units low voltage terminal block.
- A single stage thermostat is used with this equipment and must operate in conjunction with any installed accessories. Typical AC and air handler hookups are shown in Figure 12 (page 18).

CAUTION:

Isolation must be maintained from the external Class 2 output of any transformer in a cooling circuit. Use a thermostat with isolating contacts to prevent inter-connection of Class 2 outputs.

- Where local codes require that the thermostat wiring must be routed through a conduit or raceway, splices can be made inside the unit; however, all wiring must be NEC Class 1 and must be separated from incoming power leads.
- The thermostat should be mounted about 5 feet above the floor on an inside wall. **DO NOT** install the thermostat

STARTUP & ADJUSTMENTS

WARNING:

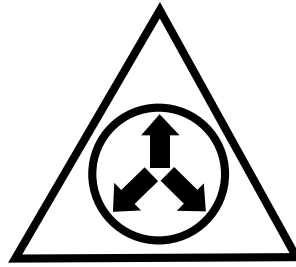

NITROGEN	
HEALTH	1
FLAMMABILITY	0
REACTIVITY	0
0 Minimal Hazard 1 Slight Hazard	

on an outside wall or any other location where its operation may be adversely affected by radiant heat from fireplaces, sunlight, or lighting fixtures, and convective heat from warm air registers or electrical appliances. Refer to the thermostat manufacturer's instruction sheet for detailed mounting and installation information.

- Install the grommet, which is packed with the unit, in the hole for low-voltage wires. Connect the low-voltage wiring to the thermostat and the outdoor unit and the appropriate screw terminal located on the control board.
NOTE: When the low voltage wires are positioned in this grommet, the grommet will prevent chafing and/or shorting of the low voltage leads.

Control Board

The control board in the air handler controls the timing sequence of the elements. The board is equipped with a 3 second blower on delay and a 15 second blower off delay in heating and a 40 second blower off delay in cooling. See Figure 13 (page 19).

Twining

B5BM air handlers are not supplied with a built in twining capability. To connect two air handlers to a common single stage AC condensing unit or heat pump, a twining kit is available for field installation. **Please follow the instructions supplied with the kit.**

NOTE: Variable speed air handlers cannot be twinned.

Heater Kits

When electric heat packages with circuit breakers are field-installed, the circuit breaker may be used as a disconnecting means in most applications. Reference the NEC and local codes for disconnect requirements.

If a heater kit is installed:

The B5BM air handler is shipped from the factory without an electric heater kit installed. If Electric heat is desired, the H6HK heater kit may be purchased separately and field installed. Determine the correct size heater kit for your unit by referring to the list below or the units rating label.

A Cabinet.....	15Kw max
B Cabinet.....	20Kw max
C Cabinet.....	30Kw max

1. Connect the 2 wire plug of the air handler to the mating 2 wire plug of the heater kit.
2. Connect the line voltage leads to the circuit breaker or terminal block provided.
3. Connect the heater kit plug with the mating receptacle on the air handler control board.

If a heater kit is not installed:

1. Remove the 2 wire plug of the air handler by cutting the wires and discarding the plug.
2. Strip the ends of the 2 air handler wires and connect to the line-voltage leads with the 2 wire nuts provided.

The evaporator coil is shipped from the factory with a nitrogen charge. Use caution when preparing coils for field connections. If repairs make it necessary for evacuation and charging, it should only be attempted by qualified, trained personnel thoroughly familiar with this equipment. Some local codes require licensed installation service personnel to service this type of equipment. Under no circumstances should the equipment owner attempt to install and/or service this equipment. Failure to comply with this warning could result in equipment damage, personal injury, or death.

Before You Start the Unit

Prior to start-up, complete the following inspections:

- ✓ Verify the unit is level and properly located with adequate clearances for servicing the unit. See Figure 1 (pg 4).
- ✓ Check condensate drain line(s) for proper drainage.
- ✓ Verify the surrounding area and top of the unit is free from obstructions and debris.
- ✓ Check all duct connections. Make sure the duct work is adequately sealed to prevent air leakage.
- ✓ Check all coil connections for leaks.
- ✓ Verify that the line voltage power leads are securely connected and the unit is properly grounded. Make sure all doors are installed before restoring power to the unit
- ✓ Verify the thermostat is wired correctly. Make sure all low voltage wires are securely connected to the correct leads of the low voltage terminal strip.
- ✓ Verify the power supply branch circuit overcurrent protection is sized properly.
- ✓ Verify filter is properly and securely installed.

IMPORTANT: Before starting the unit, install the initial charge on units that are factory shipped with a nitrogen holding charge:

1. Read all installation instructions first.
2. Purge the nitrogen holding charge.
3. Evacuate the unit to 350 - 500 microns.
4. Allow the unit to remain under vacuum for at least 30 minutes.

5. Inspect the unit rating plate for the proper type of refrigerant and quantity.
6. Weigh in the proper amount of new (or reclaimed) refrigerant.

Refrigerant Charging

The system refrigerant charge can be checked and adjusted through the service ports provided at the front panel of the outdoor unit. Use only gauge lines which have a Schrader depression device present to actuate the valve.

Air Circulation

Running the Blower Continuously

Set the thermostat's system mode to **OFF** and the thermostat's fan mode to **ON**. The blower motor should run continuously. Check for air delivery at the register(s). Ensure that there are no obstructions at the registers or in the ducts.

Turning the Blower Off

Set thermostat's fan mode to **AUTO**, the blower will shut down immediately.

NOTE: If blower is turning opposite of arrow direction, shut off main power to the unit and switch any two field wires at the disconnect. **DO NOT** alter unit wiring.

Continuous low speed fan operation (Standard Blower)

The air handler is equipped with an option of continuous low speed fan operation. When **G** is energized without **Y1** or **Y2**, the air handler will operate using the heating speed. With **G & Y1** or **Y2** energized, the air handler will operate in the selected cooling speed (including 40 sec blower-off delay).

System Cooling

1. Set the thermostat's system mode to **COOL** and fan mode to **AUTO**. Lower the thermostat's temperature mode below room temperature and observe that the blower energizes. Check the air being discharged at the register is cooler than room temperature. Verify unit refrigerant pressures are in order. Blower should be turning in direction indicated by arrow.

NOTE: DO NOT alter unit wiring. Listen for any unusual noises. Locate the source and correct as needed.

2. Allow the unit to run for several minutes and then set the thermostat's temperature above room temperature. Verify the blower cycles off with the thermostat.

System Heating

1. Set the thermostat's system mode to **HEAT** and the fan mode to **AUTO**. Increase the thermostat's temperature above room temperature and observe that the blower energizes. Check the air being discharged at the register is warmer than room temperature.
2. Allow the unit to run for several minutes and then set the thermostat's temperature below room temperature. Verify the blower cycles off with the thermostat.

Minimum Electric Heat Airflow

The minimum electric heat airflow setting controls the minimum air flow that will be produced whenever electric heater kits are used. When the electric heater kit is energized along with a heat pump, the airflow may be higher depending on the basic cooling/heat-pump airflow setting. The minimum electric heat airflow is selected by the red blower wire on 3-speed models.

Blower Configurations

Determining Nominal System Capacity

To select the appropriate airflows for the air handler, the nominal system capacity must be known. The nominal system capacity is always the nominal capacity of the outdoor unit. However, in some situations the nominal system capacity may not be the same as the nominal capacity of the air handler. Always refer to the outdoor unit rating label to determine the nominal system capacity.

NOTE: The CFM values listed in Table 2 (page 17) are not dependent on duct static pressure. The VSHE motor automatically compensates for changes in duct static pressure (within the limits of the motor).

3-Speed Units

The blower speed is preset at the factory for operation at the same speed for heating and cooling, by using the jumping terminal on the blower motor and connecting it to the desired speed with both the red and black wires connected to the jumping terminal. **NOTE:** The control board is programmed with a 40 second off delay in the cooling mode for optimum system performance and efficiency.

CAUTION:

To avoid personal injury or property damage, make sure the motor leads do not come into contact with any uninsulated metal components of the unit.

For optimum system performance and comfort, it may be necessary to change the factory set speed. See Table 2 (page 17) for airflow data. To change the blower speed:

1. Disconnect all electrical power to the unit and remove the upper door.
2. Remove the black and red wires from the blower motor jumping terminal. Discard the blower motor jumping terminal.
3. Connect the heating speed wire (red) and the cooling speed wire (black) to the desired blower speed marked on the terminal block of the blower motor.
 - Terminal 4 = Hi speed
 - Terminal 5 = Med speed
 - Terminal 6 = Low speed
4. Replace the upper door and secure it to the unit.
5. Restore power to the unit..

UNIT MAINTENANCE

WARNING:

ELECTRICAL SHOCK, FIRE OR EXPLOSION HAZARD

Failure to follow safety warnings exactly could result in serious injury or property damage.

Improper servicing could result in dangerous operation, serious injury, death or property damage.

- Before servicing, disconnect all electrical power to air handler.
- When servicing controls, label all wires prior to disconnecting. Reconnect wires correctly.
- Verify proper operation after servicing.

Proper maintenance is most important to achieve the best performance from a air handler. Some of the components and their locations are shown in Figure 11 (page 16). If any component of the air handler must be replaced, use only factory authorized replacement parts specified in the Replacement Parts List provided online.

- These maintenance instructions are primarily intended to assist qualified technicians experienced in the proper maintenance and operation of this appliance.
- Always reinstall the doors on the air handler after servicing or cleaning/changing the filters. Do not operate the air handler without all doors and covers in place.
- Verify that the thermostat is properly installed and is not being affected by drafts or heat from lamps or other appliances.
- To achieve the best performance and minimize equipment failure, it is recommended that a yearly maintenance checkup be performed. At a minimum, this check should include the following items:

Air Filter(s) - B5 Series Air Handlers are not supplied with a single air filter when shipped from the factory. It is recommended that the filter be cleaned or replaced monthly. Newly built or recently renovated homes may require more frequent changing until the construction dust has minimized. Filter sizes shown in Table 1 are available at most local retailers.

CABINET SIZE	FILTER SIZE
A	12 x 20 x 1
B	18 x 20 x 1
C	20 x 20 x 1

Table 1. Filter Sizes

WARNING:

Never operate the air handler without a filter in place. Dust and lint in the return air can build up on internal components, resulting in loss of efficiency, equipment damage, and possible fire.

Filters designed to remove smaller particles such as pollen, may require additional maintenance.

Blower Compartment - Dirt and lint can create excessive loads on the motor resulting in higher than normal operating temperatures and shortened service life. It is recommended that the blower compartment be cleaned of dirt or lint that may have accumulated in the compartment or on the blower and motor as part of the annual inspection.

Blower Fan Wheel - Inspect the blower wheel blades for accumulations of dirt and clean if necessary. Inspect mounting nut for tightness when done.

Blower Motor & Assembly - Inspect the blower assembly and motor mounting brackets for tightness and corrosion. Correct deficiencies if necessary. The blower motor contains sealed bearings and under normal operating conditions, no maintenance is necessary for the life of the equipment.

TROUBLESHOOTING

If the air handler fails to operate, check the following:

- Is the electric turned on?
- Is the thermostat operating properly?
- Are the blower compartment door(s) in place?
- Is the air handler disconnect closed?
- Has the circuit breaker tripped or the control board fuse burned open?
- Is the filter dirty or plugged?

FIGURES & TABLES

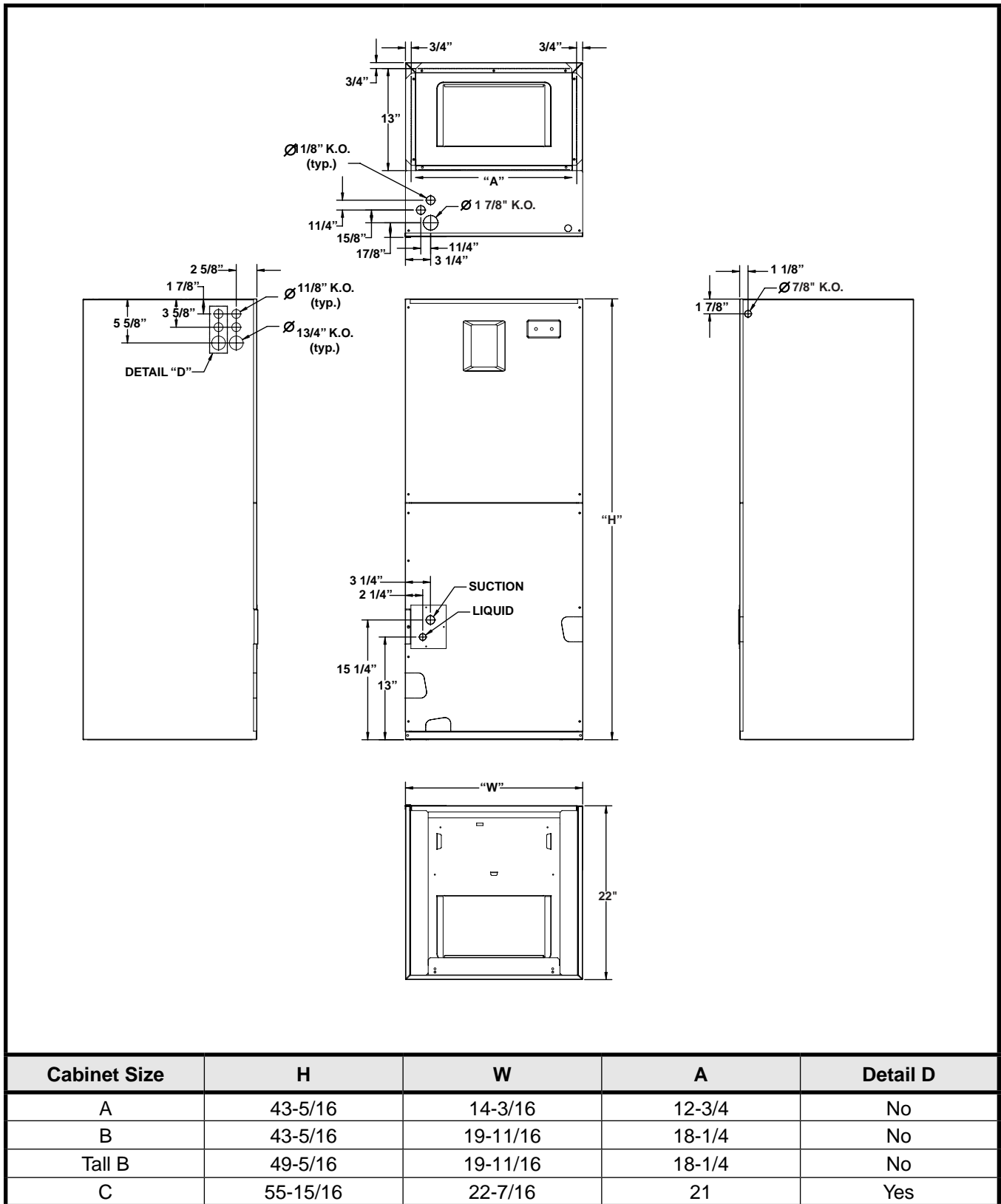

Figure 10. B5 Series Physical Dimensions

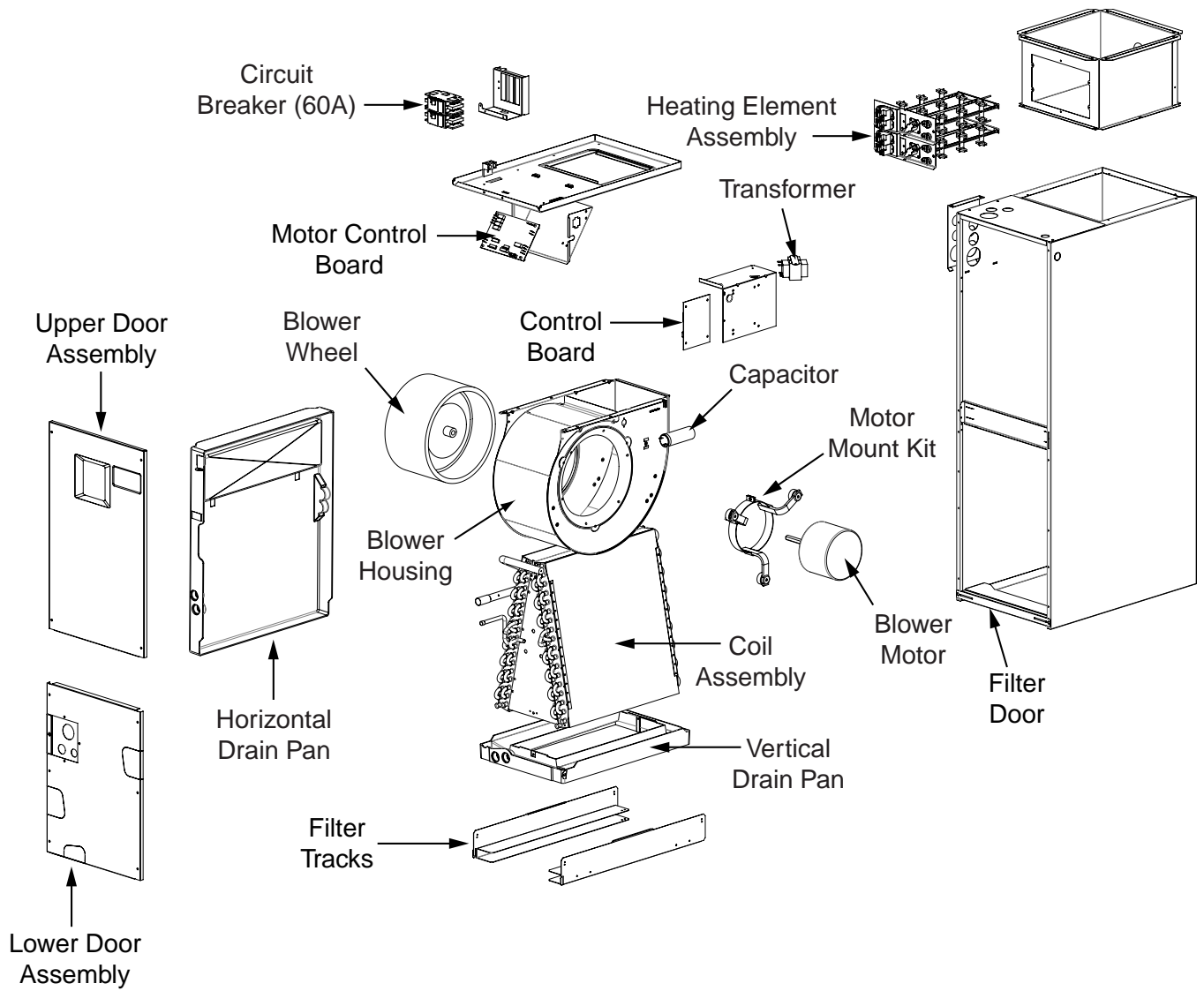

Figure 11. Air Handler Components

AIRFLOW DATA

Dry Coil ESP		0.10	0.20	0.30	0.40	0.50	0.60	0.70	0.80
*24K A-Cabinet	Low	683	647	607	563	515	463	406	345
	Corrected ESP ¹	0.00	0.07	0.19	0.30	0.42	0.53	0.65	0.76
	Medium	861	823	781	734	682	625	564	498
	Corrected ESP ¹	0.00	0.00	0.11	0.23	0.36	0.48	0.60	0.72
	High	1072	1026	975	920	860	797	730	659
	Corrected ESP ¹	0.00	0.00	0.00	0.14	0.27	0.40	0.53	0.67
*30K A-Cabinet	Low	849	825	793	753	704	647	581	508
	Corrected ESP ¹	0.00	0.04	0.15	0.27	0.38	0.50	0.62	0.74
	Medium	1118	1087	1046	997	940	874	799	717
	Corrected ESP ¹	0.00	0.00	0.04	0.17	0.29	0.42	0.55	0.68
	High	1277	1233	1184	1130	1070	1005	935	860
	Corrected ESP ¹	0.00	0.00	0.00	0.10	0.23	0.36	0.49	0.63
*24/*25K B-Cabinet	Low	708	690	664	628	584	532	471	401
	Corrected ESP ¹		0.08	0.19	0.30	0.41	0.53	0.64	0.76
	Medium	909	904	886	854	810	753	683	600
	Corrected ESP ¹			0.10	0.22	0.33	0.46	0.58	0.71
	High	1118	1132	1126	1101	1056	992	908	805
	Corrected ESP ¹				0.09	0.22	0.35	0.49	0.64
*30/*36/*37K B-Cabinet	Low	953	915	871	821	764	701	631	555
	Corrected ESP ¹	0.00	0.04	0.16	0.27	0.39	0.51	0.62	0.74
	Medium	1265	1232	1188	1133	1067	991	903	805
	Corrected ESP ¹	0.00	0.00	0.03	0.15	0.28	0.41	0.54	0.68
	High	1427	1385	1333	1270	1196	1113	1018	913
	Corrected ESP ¹	0.00	0.00	0.00	0.09	0.23	0.36	0.50	0.64
*42/*48K B-Cabinet	Low	1324	1302	1271	1233	1187	1134	1072	1003
	Corrected ESP ¹	0.00	0.06	0.17	0.27	0.38	0.49	0.61	0.72
	Medium	1485	1455	1418	1373	1320	1260	1193	1118
	Corrected ESP ¹	0.00	0.00	0.13	0.24	0.36	0.47	0.58	0.70
	High	1637	1601	1558	1506	1447	1380	1305	1223
	Corrected ESP ¹	0.00	0.00	0.00	0.21	0.33	0.44	0.56	0.68
*48/*49K C-Cabinet	Low	1605	1606	1592	1565	1524	1468	1399	1316
	Corrected ESP ¹	0	0.11	0.21	0.31	0.42	0.52	0.63	0.74
	Medium	1977	1939	1890	1830	1758	1675	1580	1474
	Corrected ESP ¹	0	0	0.18	0.28	0.39	0.50	0.61	0.72
	High	2264	2182	2095	2003	1906	1805	1698	1586
	Corrected ESP ¹	0	0	0	0.26	0.37	0.49	0.60	0.71
*60K C-Cabinet	Low	1348	1272	1198	1126	1056	988	922	858
	Corrected ESP ¹	0.00	0.11	0.22	0.33	0.44	0.55	0.65	0.76
	Med-Low	1517	1455	1390	1325	1258	1189	1120	1048
	Corrected ESP ¹	0.00	0.00	0.19	0.30	0.41	0.52	0.63	0.74
	Medium	1799	1752	1702	1650	1596	1539	1481	1420
	Corrected ESP ¹	0.00	0.00	0.00	0.25	0.36	0.47	0.58	0.69
	Med-High	1956	1910	1862	1811	1756	1699	1639	1575
	Corrected ESP ¹	0.00	0.00	0.00	0.22	0.33	0.44	0.55	0.66
High	2146	2099	2050	2000	1948	1894	1839	1783	
	Corrected ESP ¹	0.00	0.00	0.00	0.00	0.29	0.40	0.51	0.62

Notes:

- 1) Airflow is shown in cfm, +/- 5%.
- 2) External static pressure (ESP) is shown in inches w.c.
- 3) See unit nameplate or installation instructions for maximum recommended external static pressure.

Table 2. Airflow Data for B5BM Air Handlers

ELECTRICAL DIAGRAMS

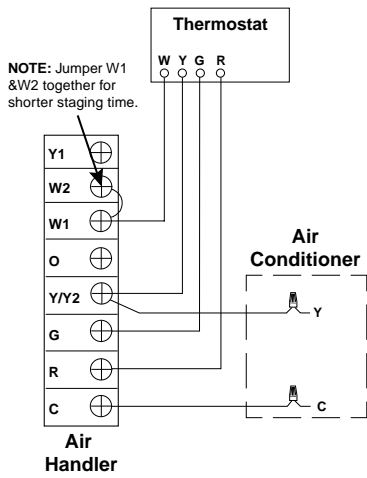

Typical Air Conditioner with Standard Air Handler

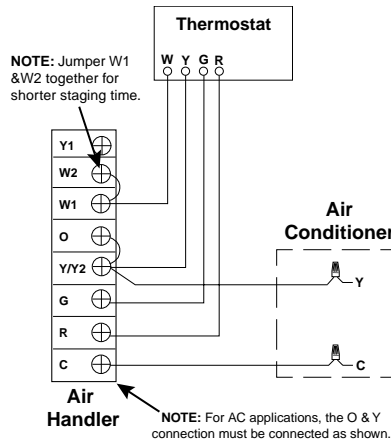

Typical Air Conditioner with Variable Speed Air Handler

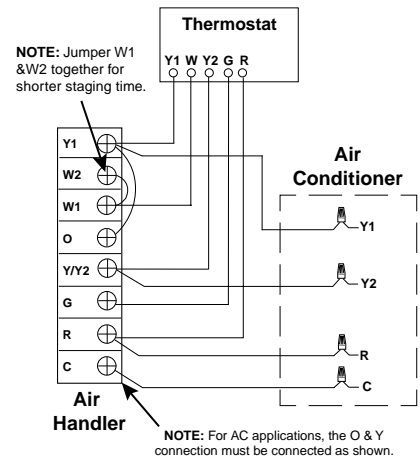

Typical 2-Stage Air Conditioner with Variable Speed Air Handler

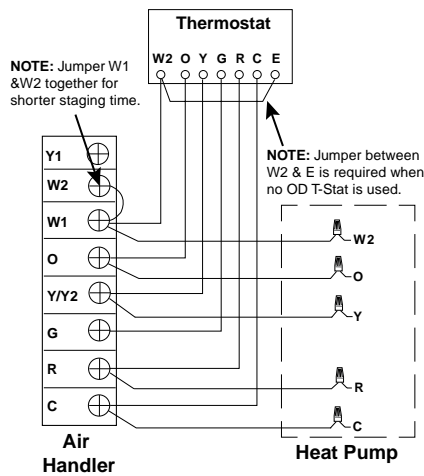

Typical Heat Pump w/Standard Air Handler

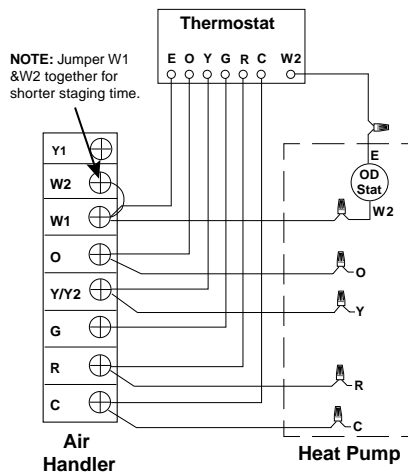

Typical Heat Pump with Optional Outdoor Thermostat and Variable Speed Air Handler

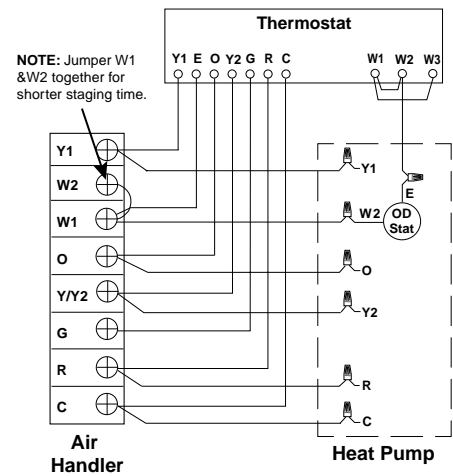

Typical 2-Stage Cooling Heat Pump with Optional Outdoor Thermostat & Variable Speed Air Handler

Figure 12. Typical Thermostat Connections

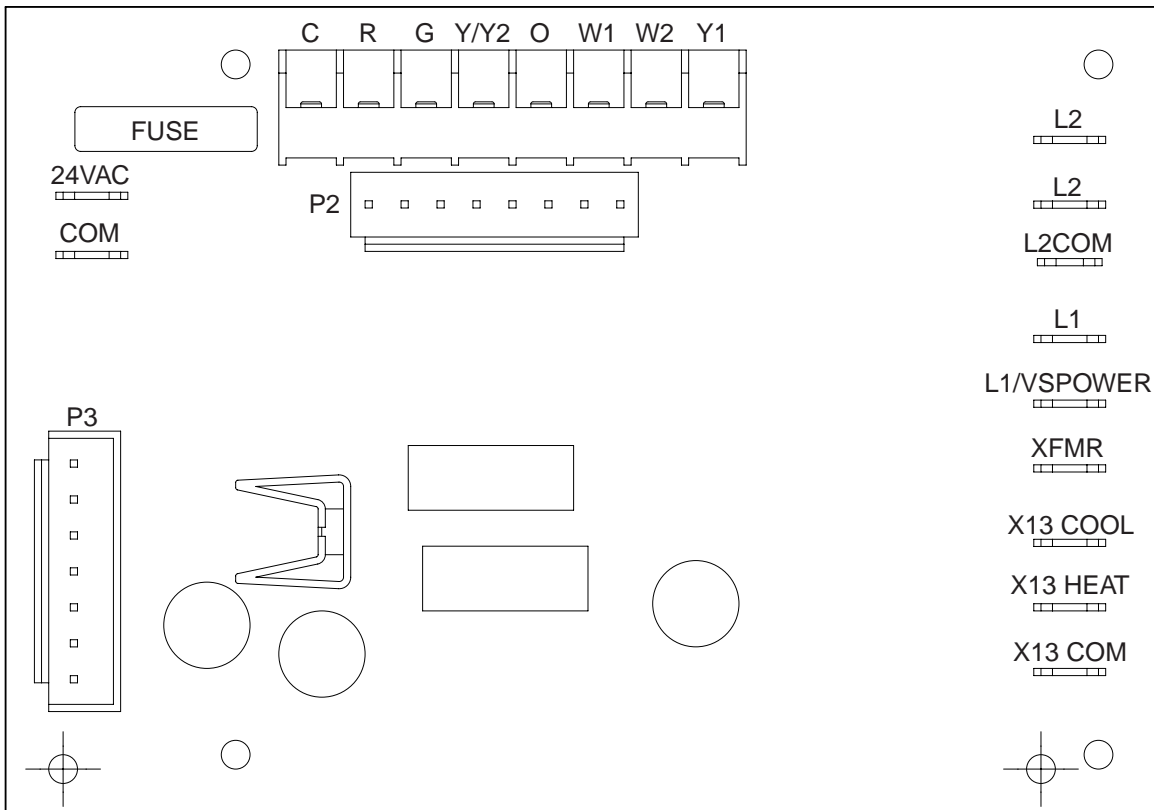

Figure 13. Motor Control Board

Motor Settings

Delay Settings (all models)

Delay Desc	Switch Number	
	7	8
Delay A	0	0
Delay B	0	1
No Delay	1	0
De-Hum	1	1

NOTE: 1 = ON
0 = OFF

	CFM			Switch Number			
	A-Cabinet	B-Cabinet	C-Cabinet	1	2	3	4
540	720	1075	0	0	0	1	
600	800	1225	0	0	0	0	
660	880	1380	0	0	1	0	
715	850	1135	1	0	0	1	
790	945	1295	1	0	0	0	
870	1040	1460	1	0	1	0	
915	1085	1525	0	1	0	1	
955	1140	1625	1	1	0	1	
1015	1205	1740	0	1	0	1	
1060	1325	1960	0	1	1	0	
1075	1265	1860	1	1	0	0	
1165	1390	2090	1	1	1	1	

Minimum Electric Heat Air-Flow

Nom. KW	CFM			Switch Number
	A-Cabinet	B-Cabinet	C-Cabinet	
0-5	700	700	-	0
0-9	-	-	700	0
6-9	800	-	-	1
6-10	-	800	-	1
10-14	950	-	-	0
10-14	-	-	950	1
11-15	-	950	-	0
15	1100	-	-	1
15-20	-	-	1100	0
16-20	-	1100	-	1
21-30	-	-	1500	1

(Modular blower supports 20kW heat max.)

WIRING DIAGRAM

Variable Speed Air Handler

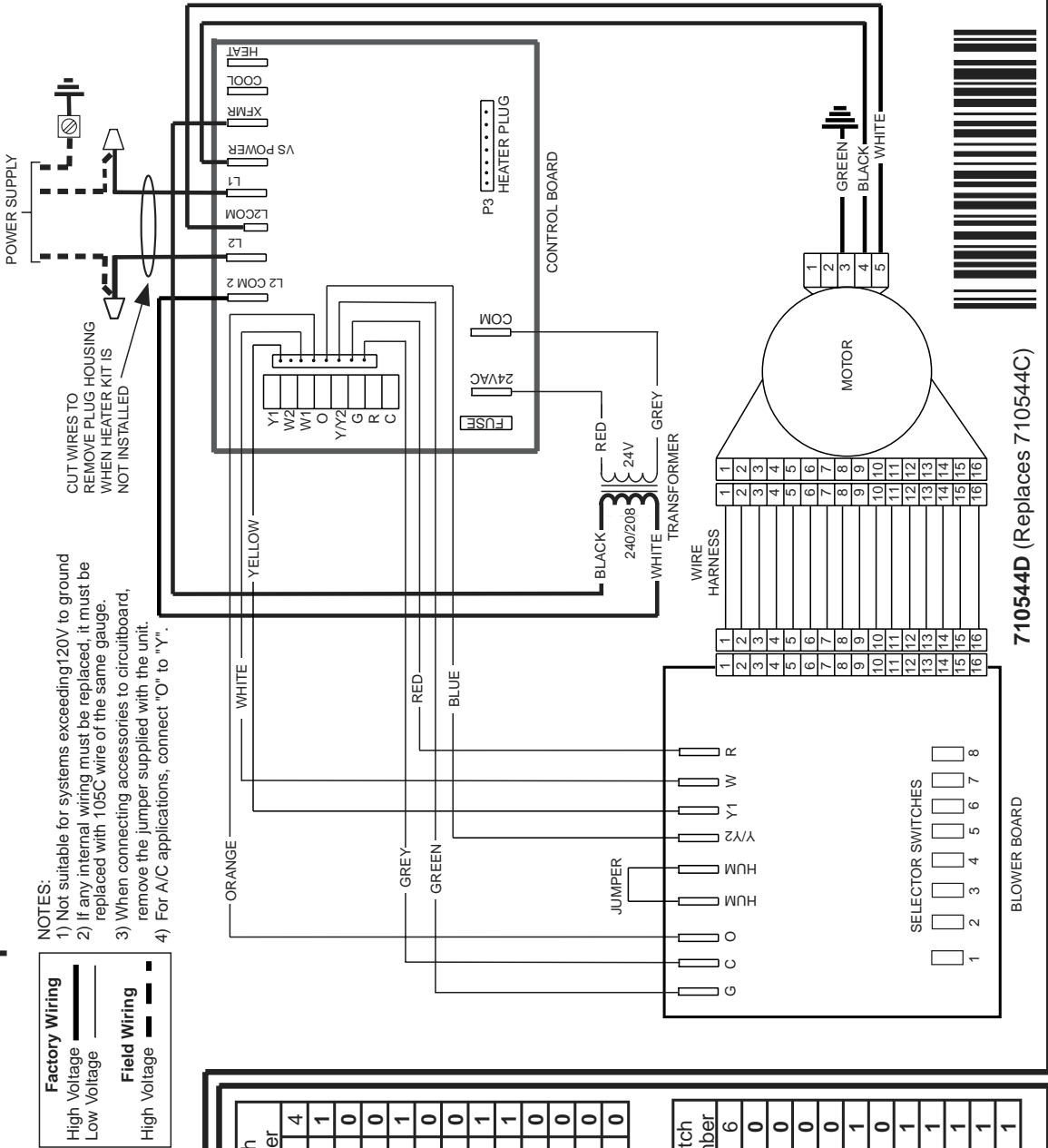
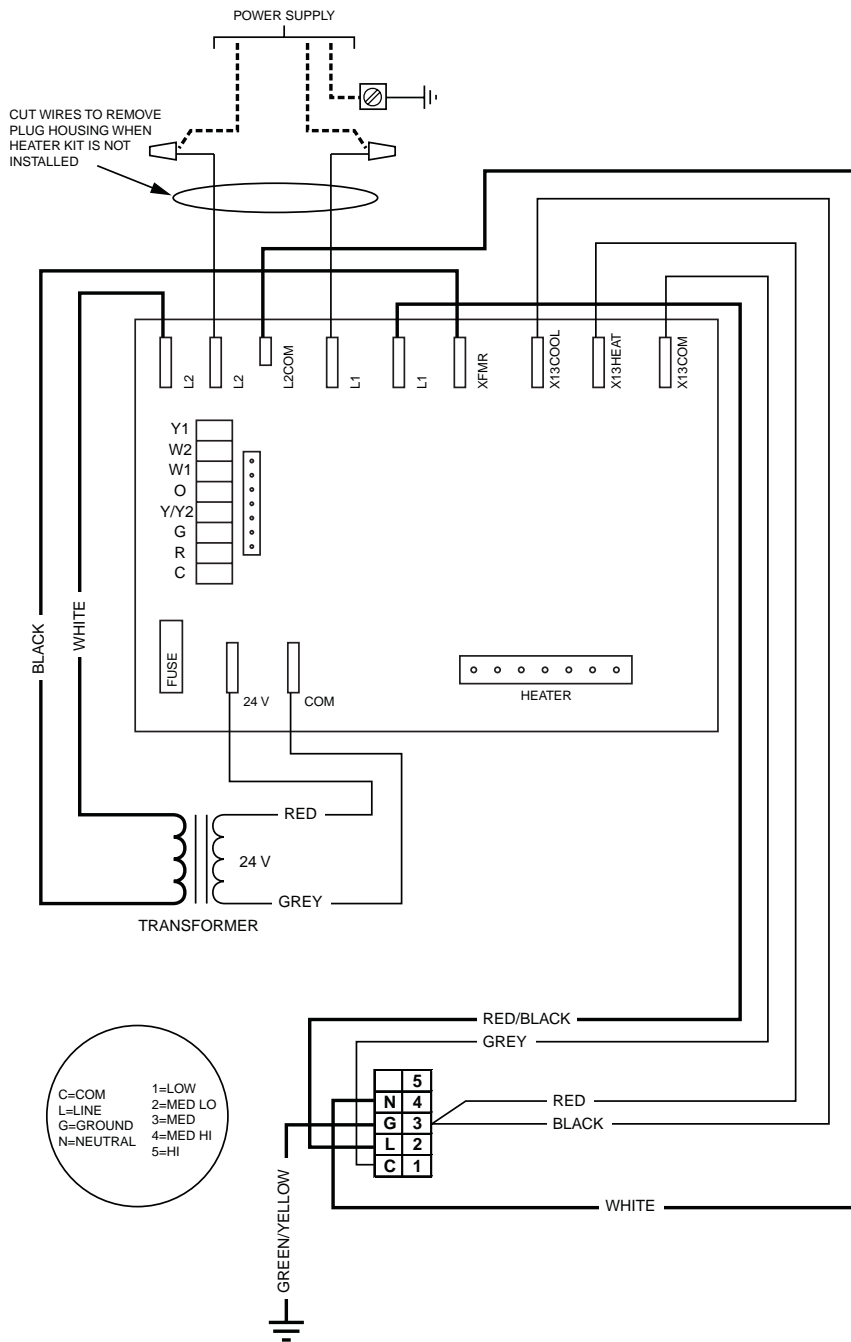

Figure 14. Wiring Diagram for B5BM Series Air Handler (Variable Speed)

WIRING DIAGRAM

Air Handler X13 MOTOR



- NOTES:**
1. The blower motor speed tap connection may not be as shown. See the Installation Instructions.
 2. Disconnect all power before servicing.
 3. Transformer may have a dual voltage primary tap. Match the tap position with the supply voltage used. If the internal wiring is replaced, use only 105°C copper wire of the same gauge.

BLOWER MOTOR PLUG		5
N = NEUTRAL	N	4
G = GROUND	G	3
L = LINE	L	2
C = COMMON	C	1
SPEED TAPS		
5 = HI		
4 = MED HI		
3 = MED		
2 = MED LOW		
1 = LOW		

C=COM	1=LOW
L=LINE	2=MED LO
G=GROUND	3=MED
N=NEUTRAL	4=MED HI
	5=HI

LEGEND:

FIELD WIRING	-----
LOW VOLTAGE	—————
HIGH VOLTAGE	—————



710545B
(Replaces 710545A)
0310

Figure 15. Wiring Diagram for B5BM Series Air Handler with X-13 Motor

WIRING DIAGRAM

Air Handler with Factory Installed Heat (8 kW, 10kW)

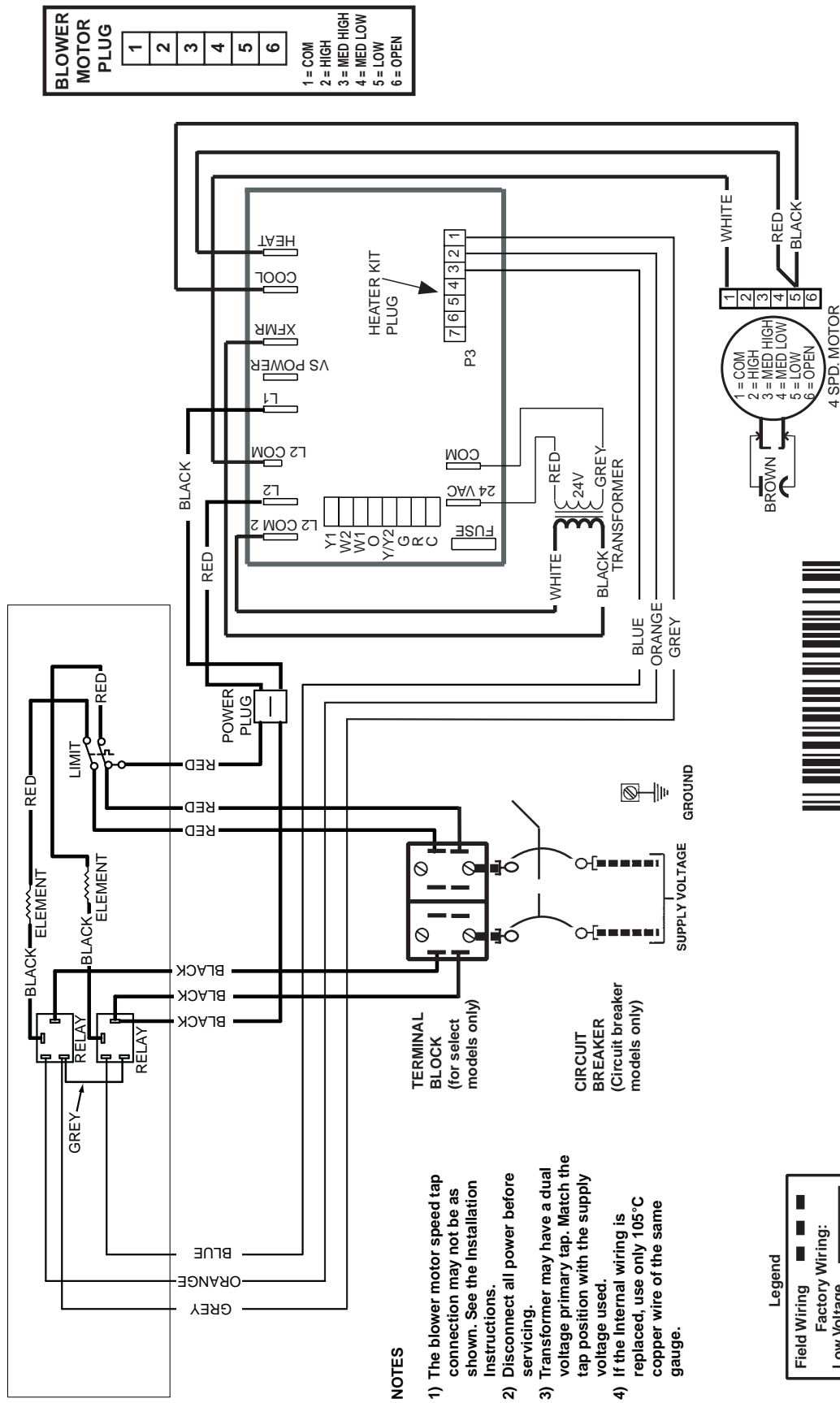

710587B (Replaces 710587A)



NOTES

- 1) The blower motor speed tap connection may not be as shown. See the installation instructions.
- 2) Disconnect all power before servicing.
- 3) Transformer may have a dual voltage primary tap. Match the tap position with the supply voltage used.
- 4) If the internal wiring is replaced, use only 105°C copper wire of the same gauge.

Legend

Field Wiring	—
Factory Wiring:	—
Low Voltage	—
High Voltage	—

Figure 16. Wiring Diagram for B5BM Series Air Handler (8kW & 10 kW)

WIRING DIAGRAM

Air Handler with Factory Installed Heat (8 kW, 10kW)

X13 MOTOR

NOTES:

- 1) The blower motor speed tap connection may not be as shown. See the Installation Instructions.
- 2) Disconnect all power before servicing.
- 3) Transformer may have a dual voltage primary tap. Match the tap position with the supply voltage used.
- 4) If the internal wiring is replaced, use only 105°C copper wire of the same gauge.

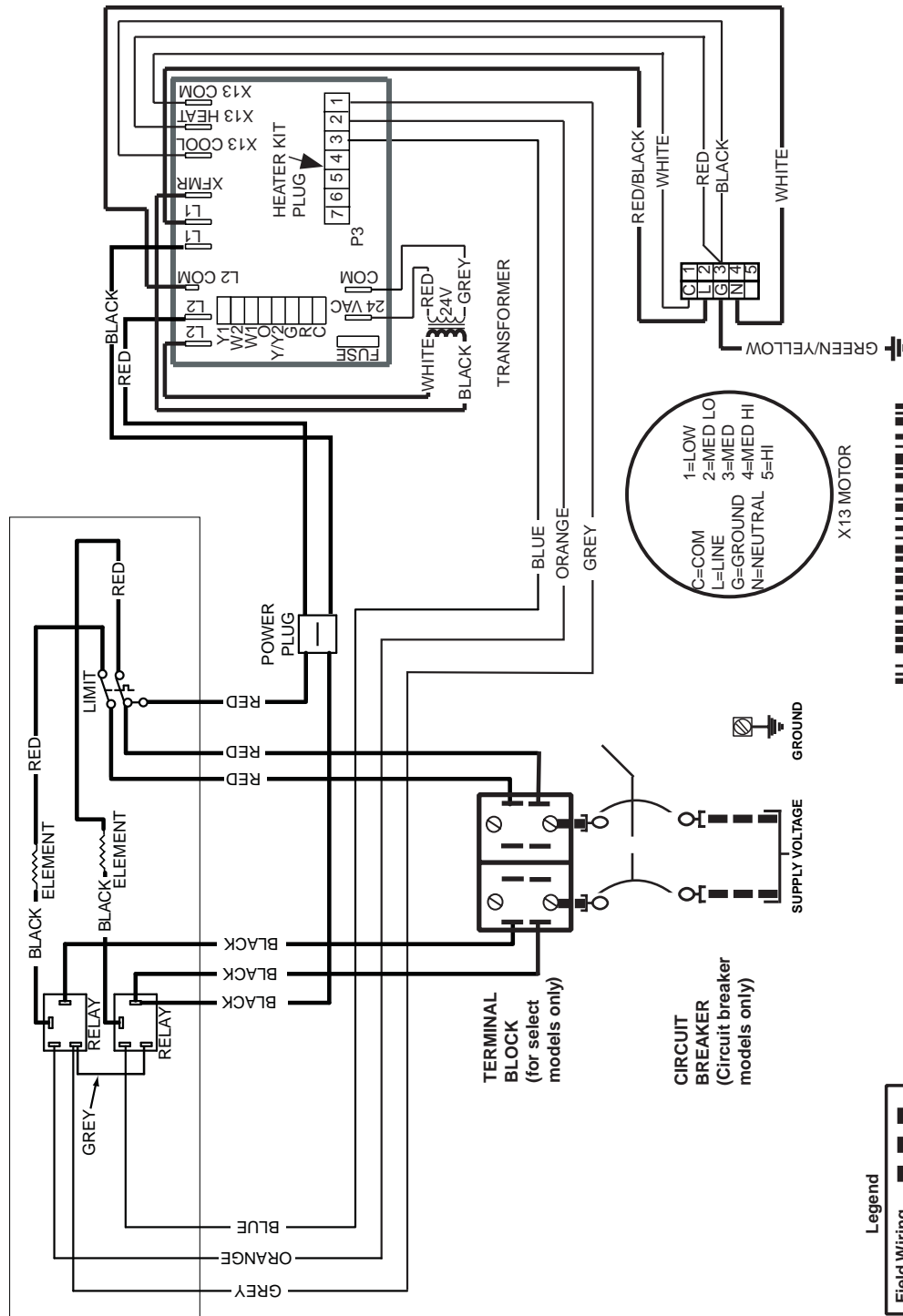

Legend

Field Wiring	---
Factory Wiring	—
Low Voltage	——
High Voltage	————

5	4	3	2	1
N	G	L	C	

BLOWER MOTOR PLUG
 N = NEUTRAL
 G = GROUND
 L = LINE
 C = COMMON

SPEED TAPS
 5 = HI
 4 = MED HI
 3 = MED
 2 = MED LOW
 1 = LOW



710541B (Replaces 710541A)

Figure 17. Wiring Diagram for B5BM Series Air Handler with X-13 Motor (8kW & 10 kW)

WIRING DIAGRAM

Air Handler with Factory Installed Heat (15 kW)

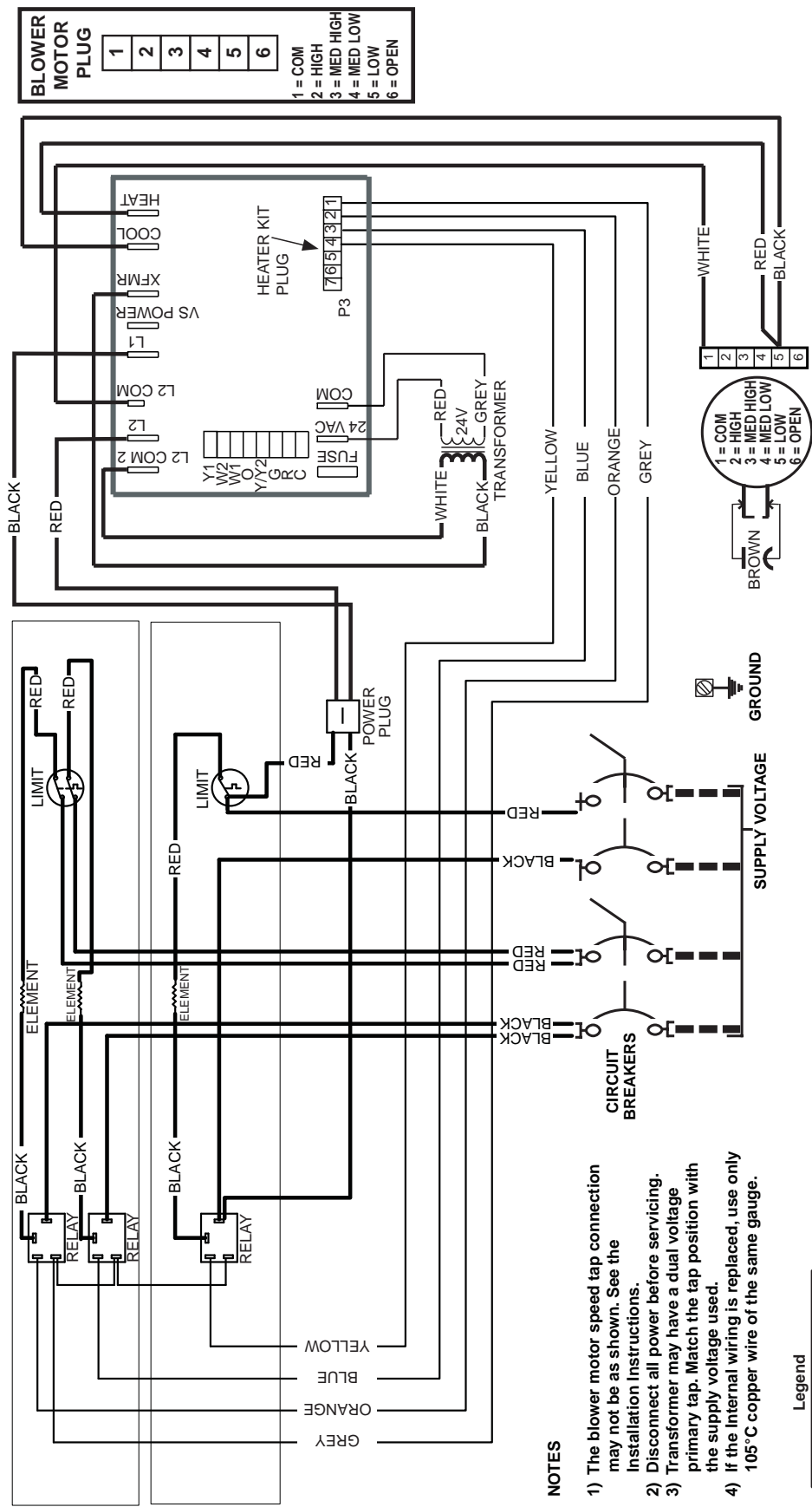

BLOWER MOTOR PLUG	
1	= COM
2	= HIGH
3	= MED HIGH
4	= MED LOW
5	= LOW
6	= OPEN

4 SPD. MOTOR	
1	= COM
2	= HIGH
3	= MED HIGH
4	= MED LOW
5	= LOW
6	= OPEN

- NOTES**
- 1) The blower motor speed tap connection may not be as shown. See the installation instructions.
 - 2) Disconnect all power before servicing.
 - 3) Transformer may have a dual voltage primary tap. Match the tap position with the supply voltage used.
 - 4) If the internal wiring is replaced, use only 105°C copper wire of the same gauge.

Legend	
Field Wiring	—
Factory Wiring:	—
Low Voltage	—
High Voltage	—



710588B (Replaces 710588A)

Figure 18. Wiring Diagram for B5BM Series Air Handler (15kW)

WIRING DIAGRAM

Air Handler with Factory Installed Heat (20 kW) X13 MOTOR

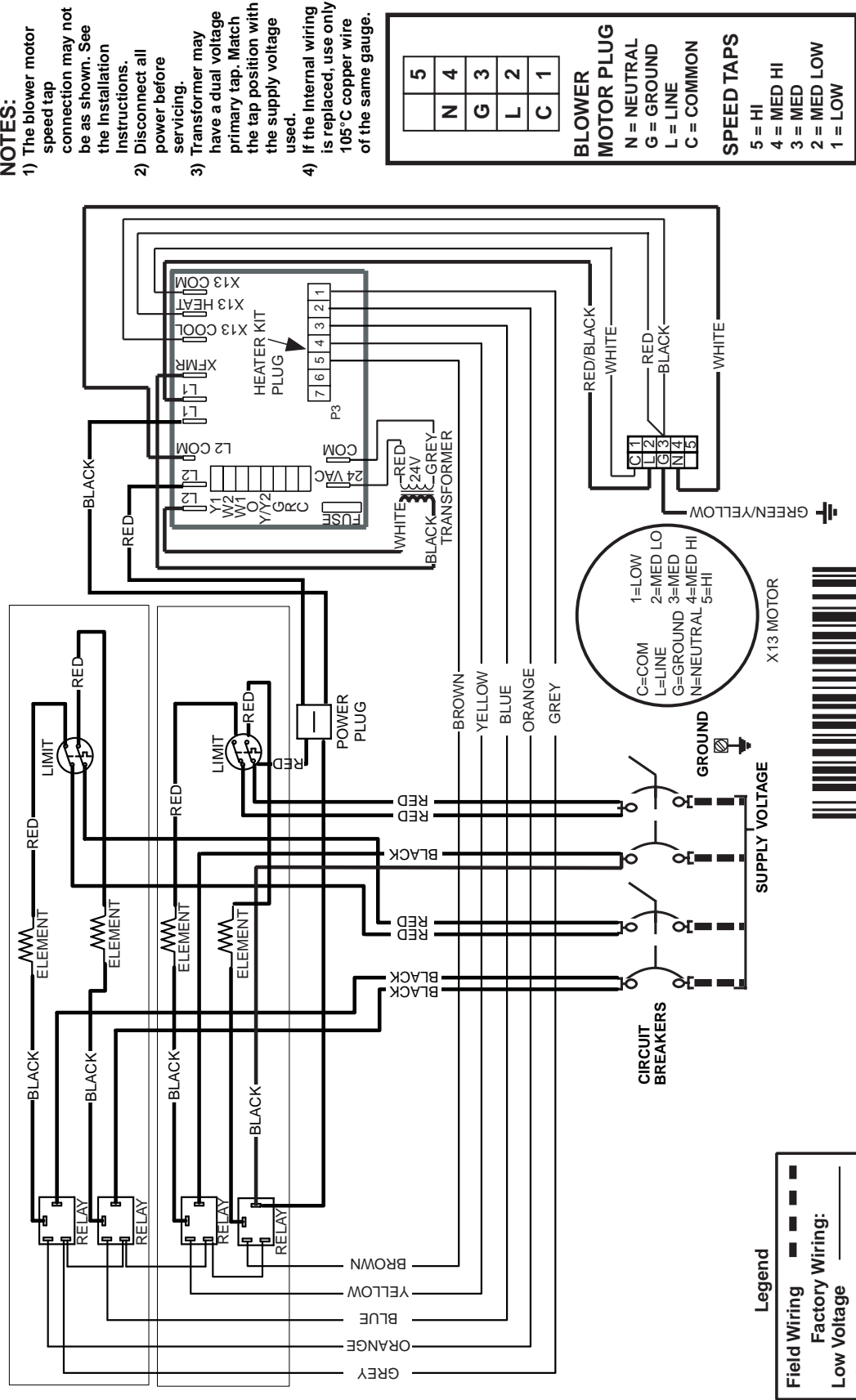

Figure 19. Wiring Diagram for B5BM Series Air Handler with X-13 Motor (20 kW)

ELECTRICAL DATA

Auxillary Heat Installed (Nom. KW)	Voltage	kW	Standard Air Handler (A & B Size)								Standard Air Handler (C Size)							
			***MAC				MOP				***MAC				MOP			
			Circuit			Single Circuit	Circuit			Single Circuit	Circuit			Single Circuit	Circuit			Single Circuit
			A	B	C		A	B	C		A	B	C		A	B	C	
NONE	240	-	-	-	-	7.5	-	-	-	15	-	-	-	8.5	-	-	-	15
005H		4.8	-	-	-	30	-	-	-	30	-	-	-	34	-	-	-	40
008H		7.5	-	-	-	45	-	-	-	50	-	-	-	48	-	-	-	50
010H		9.6	-	-	-	55	-	-	-	60	-	-	-	59	-	-	-	60
015H		14.4	55	25	-	80	60	30	-	90	59	25	-	83	60	30	-	90
020H		19.2	55	50	-	105	60	60	-	125	59	50	-	109	60	60	-	125
025H		24.0	-	-	-	-	-	-	-	-	59	50	25	134	60	60	30	150
030H		28.8	-	-	-	-	-	-	-	-	59	50	50	159	60	60	60	175
NONE		208	-	-	-	-	7.5	-	-	-	15	-	-	-	8.5	-	-	-
005H	3.6		-	-	-	27	-	-	-	30	-	-	-	30	-	-	-	40
008H	5.6		-	-	-	39	-	-	-	40	-	-	-	42	-	-	-	50
010H	7.2		-	-	-	48	-	-	-	50	-	-	-	52	-	-	-	60
015H	10.8		48	21	-	70	50	25	-	80	52	55	-	73	60	25	-	80
020H	14.4		48	43	-	92	50	50	-	100	52	43	-	95	60	50	-	100
025H	18.0		-	-	-	-	-	-	-	-	52	43	22	117	60	50	25	125
030H	21.6		-	-	-	-	-	-	-	-	52	43	43	138	60	50	50	150

Table 3. B5BM Minimum Circuit Ampacity & Maximum Overcurrent Protection

CONTROL SIGNAL	OPERATION	BOARD ACTION
W1 only	On	Stage 1 Heat on instantly Heat blower on after 3 second delay Stage 3 & 5 Heat on after 1 minute delay Stage 2 Heat on after 2 minute delay Stage 4 & 6 Heat on after 3 minute delay
	Off	Heat stages off instantly Blower off after 15 second delay
W1 & W2	On	Stage 1 Heat on instantly Heat blower on after 3 second delay Stage 3 & 5 Heat on after 10 second delay Stage 2 Heat on after 20 second delay Stage 4 & 6 Heat on after 30 second delay
	Off	Heat stages off instantly Blower off after 15 second delay
W1 & Y/Y2	On	Stage 1 Heat on instantly Cool blower on after 3 second delay Stage 3 & 5 Heat on after 1 minute delay Stage 2 Heat on after 2 minute delay Stage 4 & 6 Heat on after 3 minute delay
	Off	Heat stages & Cool blower off instantly Heat blower energizes and then turns off after 15 second delay
W1, W2 & Y/Y2	On	Stage 1 Heat on instantly Cool blower on after 3 second delay Stage 3 & 5 Heat on after 10 second delay Stage 2 Heat on after 20 second delay Stage 4 & 6 Heat on after 30 second delay
	Off	Heat stages and Cool blower off instantly Heat blower energizes and then turns off after 15 second delay

Table 4. Control Board Operation

INSTALLATION / PERFORMANCE CHECK LIST

ATTENTION INSTALLERS:

It is your responsibility to know this product better than your customer. This includes being able to install the product according to strict safety guidelines and instructing the customer on how to operate and maintain the equipment for the life of the product. Safety should always be the deciding factor when installing this product and using common sense plays an important role as well. Pay attention to all safety warnings and any other special notes highlighted in the manual. Improper installation of the air handler or failure to follow safety warnings could result in serious injury, death, or property damage.

These instructions are primarily intended to assist qualified individuals experienced in the proper installation of this appliance. Some local codes require licensed installation/service personnel for this type of equipment. Please read all instructions carefully before starting the installation. Return these instructions to the customer's package for future reference.

INSTALLER NAME:

CITY: _____ STATE: _____

INSTALLATION ADDRESS:

CITY: _____ STATE: _____

UNIT MODEL # _____

UNIT SERIAL # _____

Minimum clearances per page 4?	YES	NO
Is the unit properly installed and leveled?	YES	NO
Does condensate drain properly in both drain tubes?	YES	NO
Has the owner's information been reviewed with the home-owner?	YES	NO
Has the literature package been left near the appliance?	YES	NO

ELECTRICAL SYSTEM:

Electrical connections tight?	YES	NO
Line voltage polarity correct?	YES	NO
Supply Voltage: _____(V)		
Has the thermostat been calibrated?	YES	NO
Is the thermostat level?	YES	NO
Is the heat anticipator setting correct?	YES	NO

VENTING SYSTEM:

Is there adequate fresh air supply for ventilation?	YES	NO
Vent free from restrictions?	YES	NO
Filter properly installed?	YES	NO
Filter clean?	YES	NO
Flue connections tight?	YES	NO
Is there proper draft?	YES	NO
Return Air Temp: _____ (° F)		
Supply Air Temp: _____ (° F)		
Temperature Rise: _____ (° F)		

⚠ WARNING:

PROPOSITION 65 WARNING: This product contains chemicals known to the state of California to cause cancer, birth defects or other reproductive harm.



NORDYNE
COMPLETE COMFORT. GENUINE VALUE.

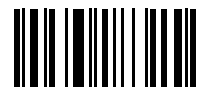

Specifications & illustrations subject to change without notice or incurring obligations.
O' Fallon, MO | Printed in U.S.A. (08/11)

708709C (Replaces 708709B)