

INSTALLATION INSTRUCTIONS**iHybrid Dual Fuel Heating & Cooling Packaged System**

Premium Model Shown

ATTENTION INSTALLERS:

It is your responsibility to know this product better than your customer. This includes being able to install the product according to strict safety guidelines and instructing the customer on how to operate and maintain the equipment for the life of the product. Safety should always be the deciding factor when installing this product and using common sense plays an important role as well. Pay attention to all safety warnings and any other special notes highlighted in the manual. Improper installation of the unit or failure to follow safety warnings could result in serious injury, death, or property damage. These instructions are primarily intended to assist qualified individuals experienced in the proper installation of this appliance. Some local codes require licensed installation/service personnel for this type of equipment. After completing the installation, return these instructions to the customer's package for future reference.

WARNING:**FIRE OR EXPLOSION HAZARD**

- Failure to follow safety warnings exactly could result in serious injury or property damage.
- Installation and service must be performed by a qualified installer, service agency or the gas supplier.
- Do not store or use gasoline or other flammable vapors and liquids in the vicinity of this or any other appliance.

WHAT TO DO IF YOU SMELL GAS

- Do not try to light any appliance.
- Do not touch any electrical switch; do not use any phone in your building.
- Leave the building immediately.
- Immediately call your gas supplier from a neighbors phone. Follow the gas suppliers instructions.
- If you cannot reach your gas supplier, call the fire department.

DO NOT DESTROY. PLEASE READ CAREFULLY AND KEEP IN A SAFE PLACE FOR FUTURE REFERENCE.

TABLE OF CONTENTS

IMPORTANT SAFETY INFORMATION	3
REQUIREMENTS & CODES	4
GENERAL INFORMATION	5
Before You Install this Unit	5
Locating the Equipment	5
Heating Load	5
COMBUSTION AIR & VENTING REQUIREMENTS ...	6
General Information	7
Vent Termination	7
CIRCULATING AIR SUPPLY	8
Air Ducts	8
Air Filter Requirements	8
Unconditioned Spaces	9
Acoustical Duct Work	9
UNIT INSTALLATION	9
Packaging Removal	9
Rigging & Hoisting	9
Clearances to Combustible Materials	9
Ground Level	9
Rooftop	9
Horizontal to Downflow Conversion	10
Condensate Drain	10
ELECTRICAL WIRING	10
Pre - Electrical Checklist	10
Line Voltage	11
Thermostat / Low Voltage Connections	11
2-Stage Heat / Cool T-stat Configuration	11
Heating Configuration	12
Heat Pump Defrost Mode	12
Checking Heat Anticipator Settings	12
Configuring the Variable Speed Blower	12
Selecting Cooling Airflow	12
Selecting Gas Heating Airflow	13
Delay Profile	13
Demand Defrost Control	13
Ambient Sensor Mounting	13
Optional Humidistat	13
Optional Comfort Alert™ Diagnostics Module	14
24VAC Power Wiring	14
Thermostat Demand Wiring	14
L Terminal Wiring	14
DC SOL Connection	14
Interpreting the Diagnostic LED's	15
LED Description	15
Installation Verification	15
Troubleshooting the Installation	15
Resetting Alert Codes	15
Grounding	15
GAS SUPPLY & PIPING	16
Leak Check	17
High Altitude Conversion	17
LP/Propane Gas Conversion	17
STARTUP & ADJUSTMENTS	18
Pre - Start Checklist	18
Start-up Procedure	18
Air Circulation	18
Short Cycle Protection	18
System Cooling Operation (2-Stage)	18
System Heating (Heat Pump Mode)	18
System Heating (Emergency Heat Mode)	19
Verifying & Adjusting Temperature Rise	19
Verifying & Adjusting Firing Rate	19
Verifying Over-Temperature Limit	19
Control Operation	19
Manifold Pressure Adjustment	20
Verifying Burner Operation	20
Refrigerant Charging	20
Charging R-410A Unit in AC Mode	20
Charging R-410A Unit in Heating Mode	20
OPERATING SEQUENCE	21
2-Stage Heating Mode (Heat Pump)	21
Gas Heating Mode (Emergency Heat)	21
2-Stage Cooling Mode	22
Fan Mode	22
EQUIPMENT MAINTENANCE	22
Cleaning of Heat Exchanger	23
Cleaning of Burners	24
TROUBLESHOOTING	24
COMPONENT FUNCTIONS	25
REPLACEMENT PARTS	25
FIGURES & TABLES	26
Figure 11. Unit Dimensions	26
Table 9. Center of Gravity & Shipping Weights	26
Airflow Information	27
Table 10. Nominal Airflow Rates & Temp Rises ...	27
Table 11. Airflow Settings for Cooling	27
Table 12. Airflow Settings for Heating	27
Gas Information	28
Table 13. Gas Pipe Capacities	28
Table 14. Gas Flow Rates	28
Figure 12. Gas Valve Label	29
Wiring Diagrams	30
Figure 13A. T-Stat Connection for Two-Stage Heating / Two-Stage Cooling	30
Figure 13B. Two-Stage, Hot Surface Ignition & Blower Control Board	30
Figure 14. Two-Stage Heat / Two-Stage Cool Heat Pump (2 & 5 Ton)	31
Figure 15. Two-Stage Heat / Two-Stage Cool w/ Optional Comfort Alert (2 & 5 Ton)	32
Figure 16. Two-Stage Heat / Two-Stage Cool Heat Pump (3 & 4 Ton)	33
Figure 17. Two-Stage Heat / Two-Stage Cool w/ Optional Comfort Alert (3 & 4 Ton)	34
Comfort Alert Troubleshooting Charts	35
Table 15. LED Diagnostics	35
Table 16. Module Wiring Troubleshooting	37
Refrigerant Charging Charts	37
Figure 18. Charging Chart for 2 Ton Units	38
Figure 19. Charging Chart for 3 Ton Units	38
Figure 20. Charging Chart for 4 Ton Units	39
Figure 21. Charging Chart for 5 Ton Units	39
INSTALLATION / PERFORMANCE CHECKLIST	40

IMPORTANT SAFETY INFORMATION

Please read all instructions before servicing this equipment. Pay attention to all safety warnings and any other special notes highlighted in the manual. Safety markings are used frequently throughout this manual to designate a degree or level of seriousness and should not be ignored. **WARNING** indicates a potentially hazardous situation that if not avoided, could result in personal injury or death. **CAUTION** indicates a potentially hazardous situation that if not avoided, may result in minor or moderate injury or property damage.

WARNING:

ELECTRICAL SHOCK, FIRE OR EXPLOSION HAZARD

Failure to follow safety warnings exactly could result in serious injury or property damage.

Improper servicing could result in dangerous operation, serious injury, death or property damage.

- Before servicing, disconnect all electrical power to the indoor blower.
 - When servicing controls, label all wires prior to disconnecting. Reconnect wires correctly.
 - Verify proper operation after servicing.
-

WARNING:

These units are fully charged with R-410A refrigerant and ready for installation. When a system is installed according to these instructions, no refrigerant charging is required. If repairs make it necessary for evacuation and charging, it should only be attempted by qualified, trained personnel thoroughly familiar with this equipment. Some local codes require licensed installation service personnel to service this type of equipment. Under no circumstances should the homeowner attempt to install and/or service this equipment. Failure to comply with this warning could result in equipment damage, personal injury, or death.

WARNING:

Do not place combustible material on or against the unit cabinet. Do not place combustible materials, including gasoline and any other flammable vapors and liquids, in the vicinity of the unit.

WARNING:

PROPOSITION 65 WARNING: This product contains fiberglass wool, a product known to the state of California to cause cancer. Disturbing the insulation of this product during installation, maintenance, or repair will expose you to fiberglass wool.

- Breathing this material may cause respiratory irritations or may cause lung cancer.
 - Fiberglass wool may also cause eye irritation, skin sensitization, or other allergic responses in susceptible individuals.
 - Always wear goggles, disposable gloves, long sleeved shirt, and appropriate breathing protection when working near this insulation. If contact with skin occurs, wash immediately with soap and water. In case of contact with eyes, flush immediately with water for at least 15 minutes. Contact a physician if needed.
-

WARNING:

The information listed below and on the next page must be followed during the installation, service, and operation of this unit. Unqualified individuals should not attempt to interpret these instructions or install this equipment. Failure to follow safety recommendations could result in possible damage to the equipment, serious personal injury or death.

- Before beginning the installation, verify that the unit model is correct for the job. The unit model number is printed on the data label. Follow all precautions in the literature, on tags, and on labels provided with the equipment. Read and thoroughly understand the instructions provided with the equipment prior to performing the installation and operational checkout of the equipment.
- Never test for gas leaks with an open flame. Use a commercially available soap solution to check all connections. See page 17.
- Installation of equipment may require brazing operations. Installer must comply with safety codes and wear appropriate safety equipment (safety glasses, work gloves, fire extinguisher, etc.) when performing brazing operations.
- This equipment is **NOT** to be used for temporary heating of buildings or structures under construction.
- Use caution when handling this appliance or removing components. Personal injury can occur from sharp

metal edges present in all sheet metal constructed equipment.

- Follow all precautions in the literature, on tags, and on labels provided with the equipment. Read and thoroughly understand the instructions provided with the equipment prior to performing the installation and operational checkout of the equipment.
- The installer should become familiar with the units wiring diagram before making any electrical connections to the unit. See the unit wiring label or Figures 13 - 16 (pages 31 - 34).

REQUIREMENTS & CODES

- **This equipment must be installed in accordance with instructions outlined in this manual, all applicable local building codes, and the current revision of the National Fuel Gas Code (NFPA54/ANSI Z223.1) or the Natural Gas and Propane Installation Code, CAN/CGA B149.1.**
- All electrical wiring must be completed in accordance with local, state and national codes and regulations and with the National Electric Code (ANSI/NFPA 70) or in Canada the Canadian Electric Code Part 1 CSA C.22.1.
- The installer must comply with all local codes and regulations which govern the installation of this type of equipment. Local codes and regulations take precedence over any recommendations contained in these instructions. Consult local building codes and the National Electrical Code (ANSI C1) for special installation requirements.
- This equipment contains liquid and gaseous refrigerant under high pressure. Installation or servicing should only be performed by qualified trained personnel thoroughly familiar with this type equipment.
- Air Ducts must be installed in accordance with the standards of the National Fire Protection Association "Standards for Installation of Air Conditioning and Ventilation Systems" (NFPA 90A), "Standard for Installation of Residence Type Warm Air Heating and Air Conditioning Systems" (NFPA 90B), these instructions, and all applicable local codes.
- Consult Table 10 (page 27), and the rating plate for the proper circulating air flow and temperature rise. It is important that the duct system be designed to provide the correct flow rates and external pressure rise. An improperly designed duct system can result in nuisance shutdowns, and comfort or noise issues.
- This unit is designed for outdoor installations only and should be located in a position as shown on page 5.
- Use only with the type of gas approved for this unit. Refer to the unit rating plate.
- Provide adequate combustion and ventilation air to the unit. See pages 6 - 8.
- Provide adequate clearances around the combustion air intake louvers. See Figure 1 (page 5).
- Combustion products must be discharged outdoors. Connect this unit to an approved vent system only, as specified on page 7.

- Additional codes listed below are for reference purposes only and do not necessarily have jurisdiction over local or state codes. Local codes and regulations take precedence over any recommendations contained in these instructions. Always consult with local authorities before installing any gas appliance.

Combustion & Ventilation Air

- US: National Fuel Gas Code (NFGC), Air for Combustion and Ventilation
- CANADA: Natural Gas and Propane Installation Codes (NSCNGPIC), Venting Systems and Air Supply for Appliances

Duct Systems

- US and CANADA: Air Conditioning Contractors Association (ACCA) Manual Q, Sheet Metal and Air Conditioning Contractors National Association (SMACNA), or American Society of Heating, Refrigeration, and Air Conditioning Engineers (ASHRAE) Fundamentals Handbook

Electrical Connections

- US: National Electrical Code (NEC) ANSI/NFPA 70
- CANADA: Canadian Electrical Code CSA C22.1

Gas Piping & Gas Pipe Pressure Testing

- US: NFGC and National Plumbing Codes
- CANADA: NSCNGPIC

General Installation

- US: Current edition of the NFGC and the NFPA 90B. For copies, contact the National Fire Protection Association Inc., Batterymarch Park, Quincy, MA 02269; or American Gas Association, 400 N. Capitol, N.W., Washington DC 20001 or www.NFPA.org.
- CANADA: NSCNGPIC. For a copy, contact Standard Sales, CSA International, 178 Rexdale Boulevard, Etobicoke (Toronto), Ontario, M9W 1R3 Canada

Safety

- US: (NFGC) NFPA 54–1999/ANSI Z223.1 and the Installation Standards, Warm Air Heating and Air Conditioning Systems ANSI/NFPA 90B.
- CANADA: CAN/CGA-B149.1—and .2–M00 National Standard of Canada. (NSCNGPIC)

GENERAL INFORMATION

The Dual Fuel iHybrid™ heat pump is designed only for outdoor rooftop or ground level installations and can be readily connected to the duct system of a home. This unit has been tested for capacity and efficiency in accordance with AHRI Standards and will provide many years of safe and dependable comfort, providing it is properly installed and maintained. With regular maintenance, this unit will operate satisfactorily year after year. Abuse, improper use, and/or improper maintenance can shorten the life of the appliance and create unsafe hazards.

To achieve optimum performance and minimize equipment failure, it is recommended that periodic maintenance be performed on this unit. The ability to properly perform maintenance on this equipment requires certain tools and mechanical skills.

Before you install this unit

- ✓ The cooling load of the area to be conditioned must be calculated and a system of the proper capacity selected. It is recommended that the area to be conditioned be completely insulated and vapor sealed.
- ✓ Check the electrical supply and verify the power supply is adequate for unit operation. Consideration should be given to availability of electric power, service access, noise, and shade. If there is any question concerning the power supply, contact the local power company.
- ✓ All units are securely packed at the time of shipment and upon arrival should be carefully inspected for damage prior to installing the equipment at the job site. Verify coil fins are straight. If necessary, comb fins to remove flattened or bent fins. Claims for damage (apparent or concealed) should be filed immediately with the carrier.
- ✓ Please consult your dealer for maintenance information and availability of maintenance contracts. Read all instructions before installing the unit.

Locating the Equipment

- Survey the job site to determine the best location for the packaged unit. The unit should be located with consideration of minimizing the length of the supply and return ducts. If practical, place the equipment and its ducts in an area where they will be shaded from the afternoon sun, when the heat load is greatest. Consideration should also be given to the accessibility of fuel, electric power, service access, noise, and shade.
- Select a solid, level position, preferably on a concrete slab, slightly above the grade level, and parallel to the home. **DO NOT PLACE UNIT UNDER THE HOME.**
- Overhead obstructions, poorly ventilated areas, and areas subject to accumulation of debris should be avoided. Do not place the unit in a confined space or recessed area where discharge air from the unit could re-circulate back through the condenser coil.
- Sufficient clearance for unobstructed airflow through the louvered control access panel and outdoor coil must be maintained in order to achieve rated performance. See Figure 1 for minimum clearance requirements.

- A clearance of at least 36 inches from the blower access panel and from the louvered control access panel is recommended for servicing and maintenance. **Where accessibility clearances are greater than clearances to combustibles, accessibility clearances must take preference.**
- The hot condenser air must be discharged up and away from the home.

Heating Load

This unit should be sized to provide the design heating load requirement. Heating load estimates can be made using approved methods available from Air Conditioning Contractors of America (Manual J); American Society of Heating, Refrigerating, and Air Conditioning Engineers; or other approved engineering methods. For installations above 2,000 ft., the unit should have a sea level input rating large enough that it will meet the heating load after deration for altitude.

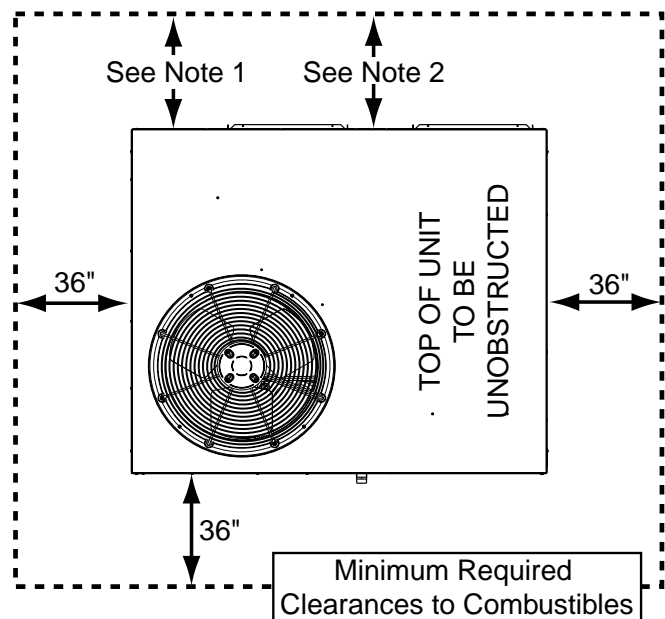

NOTE 1: 6" When coil is present on duct side.

NOTE 2: 1" When no coil is present on duct side.

Figure 1. Clearance Requirements

COMBUSTION AIR & VENTING REQUIREMENTS

WARNING:

CARBON MONOXIDE POISONING HAZARD

Failure to follow the steps outlined below for each appliance connected to the venting system being placed into operation could result in carbon monoxide poisoning or death. The following steps shall be followed with each individual appliance connected to the venting system being placed in operation, while all other appliances connected to the venting system are not in operation:

1. Seal any unused openings in the venting system.
2. Inspect the venting system for proper size and horizontal pitch, as required in the National Fuel Gas Code, ANSI Z223.1/NFPA 54 or the CSA B149.1, Natural Gas and Propane Installation Codes and these instructions. Determine that there is no blockage or restriction, leakage, corrosion and other deficiencies which could cause an unsafe condition.
3. As far as practical, close all building doors and windows and all doors between the space in which the appliance(s) connected to the venting system are located and other spaces of the building.
4. Close fireplace dampers.
5. Turn on clothes dryers and any appliance not connected to the venting system. Turn on any exhaust fans, such as range hoods and bathroom exhausts, so they are operating at maximum speed. Do not operate a summer exhaust fan.
6. Follow the lighting instructions. Place the appliance being inspected into operation. Adjust the thermostat so appliance is operating continuously.
7. Test for spillage from draft hood equipped appliances at the draft hood relief opening after 5 minutes of main burner operation. Use the flame of a match or candle.
8. If improper venting is observed during any of the above tests, the venting system must be corrected in accordance with the National Fuel Gas Code, ANSI Z223.1/NFPA 54 and/or CSA B149.1, Natural Gas and Propane Installation Codes.
9. After it has been determined that each appliance connected to the venting system properly vents when tested as outlined above, return doors, windows, exhaust fans, fireplace dampers and any other gas-fired burning appliance to their previous conditions of use.

AVERTISSEMENT:

RISQUE D'EMPOISONNEMENT AU MONOXYDE DE CARBONE

Le non-respect des consignes suivantes portant sur chacun des appareils raccordés au système d'évacuation mis en service pourrait entraîner l'empoisonnement au monoxyde de carbone ou la mort. Les consignes suivantes doivent être observées pour chaque appareil raccordé au système d'évacuation mis en service si les autres appareils raccordés au système ne sont pas en service:

1. Sceller toute ouverture non utilisée de la système d'évacuation;
2. S'assurer que la système d'évacuation présente des dimensions et une pente horizontale conformes à la norme ANSI Z223.1/NFPA 54, intitulée National Fuel Gas Code ou aux codes d'installation CSA-B149.1, ainsi qu'aux présentes instructions. S'assurer que la système d'évacuation n'est pas bloquée, restreinte, corrodée, qu'elle ne fuit pas et qu'elle ne présente aucun autre défaut potentiellement dangereux;
3. Dans la mesure du possible, fermer toutes les portes et fenêtres du bâtiment, et toutes les portes entre la pièce où se trouve l'appareil raccordé à la système d'évacuation et les autres pièces du bâtiment.
4. Fermer les registres des foyers;
5. Mettre en service les sècheuses et tout autre appareil qui n'est pas raccordé à la système d'évacuation. Faire fonctionner à régime maximal tout ventilateur d'évacuation, tel que les hottes de cuisinière et les ventilateurs de salles de bains. Ne pas mettre en service les ventilateurs d'été.
6. Respecter les instructions d'allumage. Mettre en service l'appareil à l'essai. Régler le thermostat de manière à ce que l'appareil fonctionne sans interruption;
7. Vérifier s'il y a débordement à l'orifice d'évacuation du coupe tirage des appareils dotés d'un coupe tirage 5 minutes après l'allumage du brûleur principal. Utiliser la flamme d'une allumette ou d'une chandelle.
8. Si l'on constate, au cours de l'un des essais qui précèdent, que l'évacuation est déficiente, corriger le système d'évacuation conformément à la norm ANSI Z223.1/NFPA 54, National Fuel Gas Code, et (ou) aux codes d'installation CSA B149.1.
9. Après avoir déterminé que tous les appareils raccordés à la système d'évacuation évacuent correctement tel que prescrit ci-dessus, rouvrir les portes et les fenêtres et remettre les ventilateurs d'évacuation, les registres de foyers et tout autre appareil fonctionnant au gaz à leur état de fonctionnement initial.

General Information

⚠ WARNING:

Installation methods other than those described in the following sections must comply with the National Fuel Gas Code and all applicable local codes for providing sufficient combustion air to the furnace.

Provisions must be made during the installation of this unit that provide an adequate supply of air for combustion.

- Instructions for determining the adequacy of an installation can be found in the current revision of the NFGC (ANSI Z223.1 / NFPA54). **Consult local codes for special requirements.** These requirements are for US installations as found in the NFGC.
- The requirements in Canada (B149.1) are structured differently. Consult with B149.1 and local code officials for Canadian installations.

⚠ WARNING:

Combustible air must not be drawn from a contaminated atmosphere. Excessive exposure to contaminated combustion air will result in safety and performance related problems.

To maximize heat exchanger life, the combustion air must be free of chemicals that can form corrosive acidic compounds in the combustion gases. The recommended source of combustion air is to use clean air from outside. **DO NOT place any chemicals with flammable or caustic vapors or these other corrosive chemicals near the vent termination:**

- Gasoline/Kerosene
- Permanent wave solutions
- Chlorinated waxes and cleaners
- Chlorine based swimming pool chemicals
- Water softening chemicals
- De-icing salts or chemicals
- Carbon tetrachloride
- Halogen type refrigerants
- Cleaning solvents
- Cements, glues, paint removers, varnishes, etc.
- Hydrochloric acid
- Masonry acid washing materials
- Plumbing Stack

Air openings in the door of the unit, warm air registers, and return air grilles must never be restricted. If the unit does not receive an adequate supply of air for combustion, the flame roll-out control located above the burners will open, turning off the gas supply to the burners. This safety device is a manually reset switch. **IMPORTANT NOTE: DO NOT install jumper wires across this control to defeat its function or reset the control without identifying and correcting the fault condition.**

If this control must be replaced, use only factory authorized replacement parts. See the Replacement Parts List on page 25.

Vent Termination

This unit has been equipped with an integral venting system and designed to operate only with this venting system. No additional venting shall be used. This unit must be vented to the outdoors.

⚠ WARNING:

This unit is intended for outdoor installation only. Do not vent the unit through a conventional venting system.

A vent cover assembly has been supplied with the unit and can be found secured to the gas controls within the control area of this unit. Figure 2 shows the proper installation of the vent cover assembly over the vent outlet on the exterior of the corner panel. The fasteners used to secure the vent cover assembly have been included in the owner's package. **The vent cover assembly must be installed to assure proper operation of the unit.**

The following list summarizes the requirements for the location of the vent system termination:

- The location of the vent termination must be consistent with the National Fuel Gas Code (ANSI Z223.1) or CAN/CGA-B149 Installation Codes.
- The vent termination must be located at least 4 feet horizontally from any electric meters, gas meters, regulators, and relief equipment.
- The vent termination must be located at least 3 feet above any forced air inlet located within 10 feet.
- The vent termination must be located at least 4 feet below, 4 feet horizontally from, or 1 foot above any door, window, or gravity air inlet into any building.
- The vent termination must be located at least 1 foot above grade.
- The unit should be installed in a way that prevents any obstruction of the vent termination during accumulating snow.

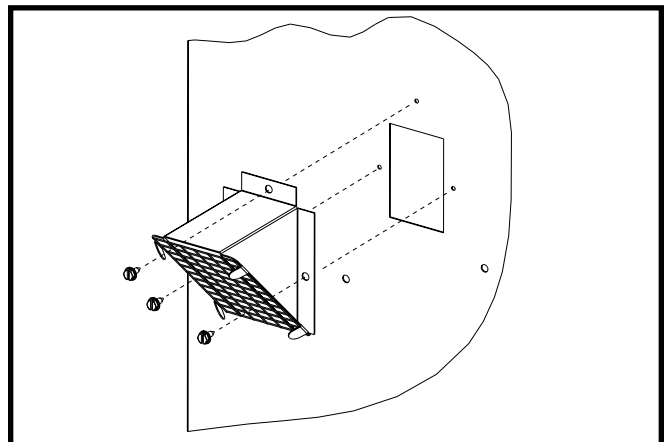

Figure 2. Vent Assembly

- The unit installation shall avoid areas where condensate drainage may cause problems by dropping on planters or patios, etc. Also verify exhaust gases will not impinge on windows or building surfaces, which may be compromised or damaged by condensation.
- Do not install the unit such that exhaust from the vent termination is directed into window wells, stairwells, under decks, or in alcoves or similarly recessed areas. The vent termination must not be located above any public walkways.

CIRCULATING AIR SUPPLY

WARNING:

Do not allow combustion products to enter the return air ductwork or the circulating air supply. Failure to prevent the circulation of combustion products into the living space can create potentially hazardous conditions including carbon monoxide poisoning that could result in personal injury or death.

All return ductwork must be secured to the unit with sheet metal screws. All return ductwork must be adequately sealed and all joints must be taped. When return air is provided through the bottom of the unit, the joint between the unit and the return air plenum must be air tight.

The roof curb or cement pad on which the unit is mounted must provide sound physical support of the unit with no gaps, cracks, or sagging between the unit and the curb or pad.

Return air and circulating air ductwork must not be connected to any other heat producing device such as a fireplace insert, stove, etc. Doing so may result in fire, explosion, carbon monoxide poisoning, personal injury, or property damage.

Air Ducts

This unit is designed only for use with a supply and return duct. Air ducts should be installed in accordance with the standards of the National Fire Protection Association “Standard for Installation of Air Conditioning Systems” (NFPA 90A), “Standard for Installation of Residence Type Warm Air Heating and Air Conditioning Systems” (NFPA 90B), and all applicable local codes. NFPA publications are available by writing to: National Fire Protection Association, Batterymarch Park, Quincy, ME 02269 or visit www.nfpa.org on the web.

- Design the duct work according to Manual D by the Air Conditioning Contractors of America (ACCA).
- The ducts must be properly sized not to exceed the unit maximum ESP rating at 400 scfm per nominal ton of cooling capacity.

- Duct work should be attached directly to the unit flanges for horizontal applications.
- If roof curb is installed, the ducts must be attached to the curb hangers, not the unit.
- It is recommended that the outlet duct be provided with a removable access panel. The opening should be accessible when the unit is installed in service and shall be sized so that smoke or reflected light may be observed inside the casing to indicate the presence of leaks in the heat exchanger. The cover for the opening shall be attached in a way that will prevent leaks.
- If outside air is utilized as return air to the unit for ventilation or to improve indoor air quality, the system must be designed so that the return air to the unit is not less than 50° F (10° C) during heating operation.
- If a combination of indoor and outdoor air is used, the ducts and damper system must be designed so that the return air supply to the furnace is equal to the return air supply under normal, indoor return air applications.

Air Filter Requirements

WARNING:

Never operate the unit without a filter in place. Dust and lint could accumulate on internal parts, resulting in loss of efficiency, equipment damage and possible fire.

- This unit is not supplied with air filter(s) and has no factory equipped means for accommodating internal filter(s). A suitable air filter must be installed upstream of the evaporator coil of the return air system. Refer to Table 1 for recommended filter sizes.
- All return air must pass through the filters before entering the evaporator coil. It is important that all filters be kept clean and replaced frequently to ensure proper operation of unit. Dirty or clogged filters will reduce the efficiency of the unit and result in unit shutdowns.
- Air filter pressure drop must not exceed 0.08 inches WC.
- Horizontal and downflow Installations require the air filter system be installed in the return air ductwork.

NOTE TO INSTALLER: After installing or replacing the filtration system for this unit, add the following statement on or adjacent to the filter service panel: **“Replace filter(s) installed in your system only with the same dimensional size filters that are being replaced.”**

Nominal Cooling (Tons)	Approximate Air Flow Range (CFM)	Approximate Filter Area (Sq. In.)*	Recommended Filter Size (In. x In.)
2.0	700 - 900	450	18 x 25
3.0	1,000 - 1,300	625	25 x 25
4.0	1,400 - 1,800	900	18 x 25 (2 required)
5.0	1,700 - 2,150	1100	22 x 25 (2 required)

* Based on velocity of 300 ft/min for disposable filters and 500 ft/min for high velocity (cleanable) Filters.

Table 1. Air Filter Requirements

Unconditioned Spaces

All duct work passing through unconditioned space must be properly insulated to minimize duct losses and prevent condensation. Use insulation with an outer vapor barrier. Refer to local codes for insulation material requirements.

Acoustical Duct Work

Certain installations may require the use of acoustical lining inside the supply duct work.

- Acoustical insulation must be in accordance with the current revision of the Sheet Metal and Air Conditioning Contractors National Association (SMACNA) application standard for duct liners.
- Duct lining must be UL classified batts or blankets with a fire hazard classification of FHC-25/50 or less.
- Fiber duct work may be used in place of internal duct liners if the fiber duct work is in accordance with the current revision of the SMACNA construction standard on fibrous glass ducts. Fibrous duct work and internal acoustical lining must be NFPA Class 1 air ducts when tested per UL Standard 181 for Class 1 ducts.

UNIT INSTALLATION

Packaging Removal

Remove the shipping carton and User's Manual from the equipment. Take care not to damage the tubing connections when removing the carton. For rooftop installations, remove and discard the two supports attached beneath the unit.

Rigging & Hoisting

WARNING:

To avoid the risk of property damage, personal injury, or death, it is the rigger's responsibility to ensure that whatever means are used to hoist the unit are safe and adequate:

- **The lifting equipment must be adequate for the load. Refer to Table 9 (page 26) for unit weights.**
- **The unit must be lifted from the holes in the base rails using cables or chains.**
- **Spreader bars are required to protect the unit and ensure even loading.**
- **Keep the unit in an upright position at all times. The rigging must be located outside the unit's center of gravity. Refer to Figure 10 (page 26) for locating the center of gravity.**
- **All panels must be securely in place during rigging and hoisting.**

Clearances to Combustible Materials

These units are certified as combination heating and cooling equipment for outdoor rooftop or ground level installations. Units may be installed on combustible flooring or Class A, B, or C roofing material when used with bottom supply and return air ducts as long as the following requirements are met:

- If using bottom discharge with return air ducts a roof curb must be installed prior to unit installation. See Rigging and Hoisting section for setting of the unit.
- Sufficient clearance for unobstructed airflow through the outdoor coil must also be maintained in order to achieve rated performance. See page 5 for information about locating the equipment.

Ground Level

Ground level installations must be located according to local building codes or ordinances and these requirements:

- Clearances must be in accordance with those shown in Figure 1 (page 5).
- A suitable mounting pad (Figure 3) must be provided and be separate from the building foundation. The pad must be level to ensure proper condensate disposal and strong enough to support the unit's weight. The slab height must be a minimum of 2" (5cm) above grade and with adequate drainage.
- Remove and discard the horizontal Supply and Return duct covers located on the rear of the unit. Form duct attachment flanges by bending the sheet metal outward 90 degrees along the perforated lines.
- Firmly attach ductwork directly to these flanges with screws or other approved mechanical connections and not to the Supply/Return air panels to avoid damage to internal components of the equipment. Once completed use approved duct sealing methods to ensure an air and watertight seal is achieved.

Rooftop

Rooftop installations must be located according to local building codes or ordinances and these requirements:

- The roof must be capable of handling the weight of the unit. For unit weights, see Table 9. Reinforce the roof if necessary.
- The appropriate accessory roof curb (Figure 4, page 10) must be installed prior to unit installation. The roof curb must be square and level to ensure proper condensate drainage. **Please follow all instructions provided with the kit.**
- Secure roof curb or frame to roof using acceptable mechanical methods per local codes. **NOTE:** Make sure the two supports beneath the unit have been removed.

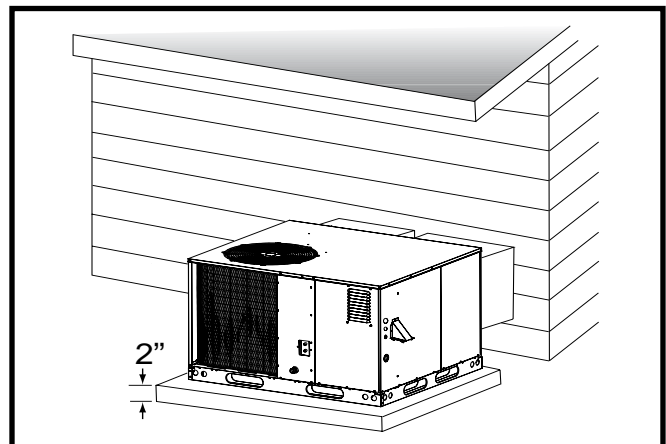

Figure 3. Ground Level Installation

Horizontal to Downflow Conversion

The unit is shipped ready for horizontal duct connections. If down flow ducts are required, the unit must be converted following the steps below for both the supply and return ducts.

1. Remove both horizontal duct caps.
2. Locate the duct cap inside the duct openings and remove the screw holding it in place.
3. Lift the cap out of the unit. (**Hint:** The cap can be pushed up from the bottom by reaching through the fork slot).
4. Cover the horizontal duct openings with the horizontal duct caps. The insulation will be on the indoor side.
5. Fasten the cover with screws to seal.

Condensate Drain

Condensate is removed from the unit through the 3/4" female pipe fitting (Figure 5) located on the front side of the unit. Install a 2 inch condensate trap in the drain line of the same size and prime with water. When connecting rigid drain line, hold the female fitting with a wrench to prevent twisting. **Do not over tighten!** Refer to local codes and restrictions for proper condensate disposal requirements.

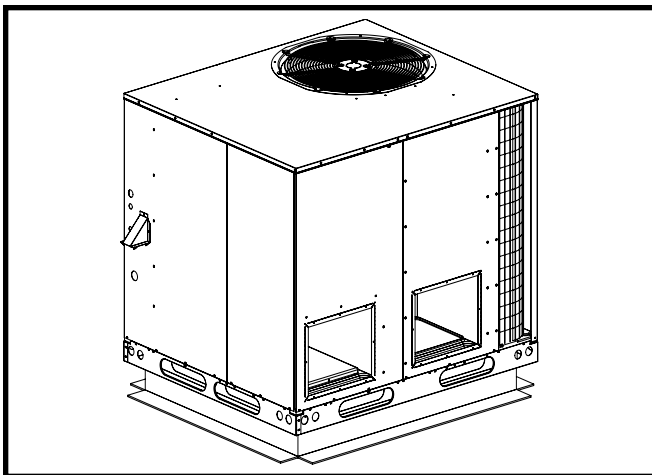

Figure 4. Roof Top Installation

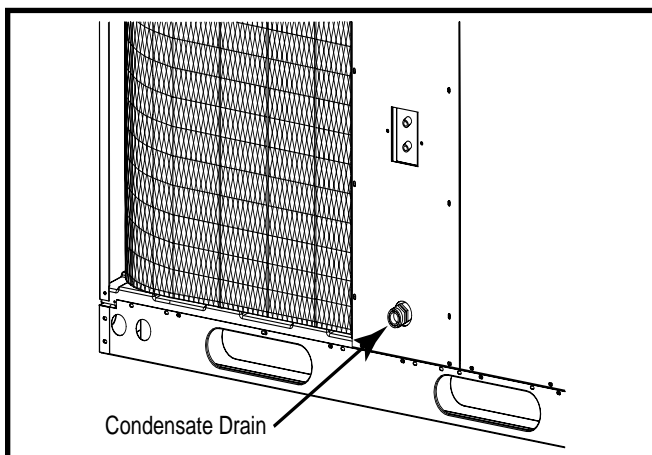

Figure 5. Condensate Drain Location

ELECTRICAL WIRING

⚠ WARNING:

ELECTRICAL SHOCK, FIRE OR EXPLOSION HAZARD

Failure to follow safety warnings exactly could result in serious injury or property damage.

Improper servicing could result in dangerous operation, serious injury, death or property damage.

- **Before servicing, disconnect all electrical power to furnace.**
- **When servicing controls, label all wires prior to disconnecting. Reconnect wires correctly.**
- **Verify proper operation after servicing."**

⚠ AVERTISSEMENT:

RISQUE DE CHOC ÉLECTRIQUE, D'INCENDIE OU D'EXPLOSION

Le non-respect des avertissements de sécurité pourrait entraîner un fonctionnement dangereux de l'appareil, des blessures graves, la mort ou des dommages matériels.

Un entretien incorrect pourrait entraîner un fonctionnement dangereux de l'appareil, des blessures graves, la mort ou des dommages matériels

- **Couper toute alimentation électrique au générateur d'air chaud avant de procéder aux travaux d'entretien.**
- **Au moment de l'entretien des commandes, étiquetez tous les fils avant de les débrancher. S'assurer de les raccorder correctement.**
- **S'assurer que l'appareil fonctionne adéquatement après l'entretien.**

- Electrical connections must be in compliance with all applicable local codes and ordinances, and with the current revision of the National Electric Code (ANSI/NFPA 70).
- For Canadian installations the electrical connections and grounding shall comply with the current Canadian Electrical Code (CSA C22.1 and/or local codes).

Pre-Electrical Checklist

- ✓ Verify the voltage, frequency, and phase of the supply source match the specifications on the unit rating plate.
- ✓ Verify that the service provided by the utility is sufficient to handle the additional load imposed by this equipment. See Table 2 (page 11) or the unit wiring label for proper high and low voltage wiring.

Model Number	Maximum Heating Input	Nominal Electrical Supply	Voltage Range		Compressor		Fan Motor FLA	Indoor Blower FLA	Single Circuit	
			Min	Max	RLA	LRA			MCA	MOP
X24K080CA	80,000	208-230/60/1	187	253	11.7	58.3	0.91	4.3	20.3	30.0
X36K100CA	100,000	208-230/60/1	187	253	15.3	83.0	2.6	6.8	29.0	40.0
X48K120CA	120,000	208-230/60/1	187	253	21.2	104.0	2.6	9.1	38.6	50.0
X60K120CA	120,000	208-230/60/1	187	253	28.8	152.9	1.46	9.1	47.0	70.0

Note: FLA = Full Load Amps; LRA = Lock Rotor amps; RLA = Rated Load Amps.

Table 2. Electrical Data

√ Verify factory wiring is in accordance with the unit wiring diagram (Figures 13 - 16, pages 31 - 34). Verify none of the connections loosened during shipping or installation.

Line Voltage

- The line voltage to the unit should be supplied from a dedicated branch circuit containing the correct fuse or circuit breaker for the unit.
- **An electrical disconnect must be located within sight of and readily accessible to the unit.** This switch shall be capable of electrically de-energizing the outdoor unit. See unit data label for proper incoming field wiring. Any other wiring methods must be acceptable to authority having jurisdiction.
- Use only copper wire for the line voltage power supply to this unit (Table 3, page 12). Use proper code agency listed conduit and a conduit connector for connecting the supply wires to the unit. Use of rain tight conduit is recommended.
- Provide power supply for the unit in accordance with the unit wiring diagram and the unit rating plate.
- Overcurrent protection must be provided at the branch circuit distribution panel and sized as shown on the unit rating label and according to applicable local codes. See the unit rating plate for maximum circuit ampacity and maximum overcurrent protection limits.
- A wiring diagram is located on the inside cover of the control access panel of the outdoor unit. The installer should become familiar with the wiring diagram before making any electrical connections to the outdoor unit. See Figures 13 - 16.
- If any of the original wires supplied with the unit must be replaced, they must be replaced with material of the same gauge and temperature rating.
- Units are shipped from the factory wired for 240 volt transformer operation. For 208V operation, remove the lead from the transformer terminal marked 240V and connect it to the terminal marked 208V.
- Connect the line-voltage leads to the terminals on the contactor inside the control compartment.

Thermostat / Low Voltage Connections

- These Gas / Electric units are designed to operate with a 24 VAC Class II control circuit. The control circuit wiring must comply with the current provisions of the NEC (ANSI/NFPA 70) and with applicable local codes having jurisdiction. Thermostat connections should be

made in accordance with the instructions supplied with the thermostat and the indoor equipment.

- These units use a special 2 speed compressor to achieve a high level of efficiency in a compact frame. **A 2 stage heat / 2 stage cool thermostat with back-up fossil fuel heat capability is required with the Dual Fuel iHybrid™ heat pump packaged system.** This system is capable of providing two stages of cooling, two stages of heating in heat pump mode and an additional 2 stages of secondary gas heating. See Figure 12 (page 30)
- The low voltage wires must be properly connected to the units low voltage terminal block. Route 24V control wires through the gas furnace side of the unit. Recommended wire gauge and wire lengths for typical thermostat connections are listed in Table 4 (page 12).
- The thermostat should be mounted about 5 feet above the floor on an inside wall. DO NOT install the thermostat on an outside wall or any other location where its operation may be adversely affected by radiant heat from fireplaces, sunlight, or lighting fixtures, and convective heat from warm air registers or electrical appliances. Refer to the thermostat manufacturer's instruction sheet for detailed mounting information.

2 Stage Heat/Cool Thermostat Configuration
For proper operation and highest efficiency, a 2 Stage Heat Pump thermostat with back-up fossil fuel capabilities is required for this product. A 2 stage heat pump thermostat is required to control the special 2 speed compressor in both Heating and Cooling modes of heat pump operation. The 2 Stage Heat Pump thermostat will also allow the unit to operate as a two stage gas heat system while set in the Emergency Heat mode.

Connect the low voltage thermostat wires between terminals R (24VAC), Y1 (1st Stage Cool), G (Fan), Y2 (2nd Stage Cool), W1 (1st Stage Heat), W2 (2nd Stage Heat), C (24V Com.), E (Emer. Heat), O or O/B (Reversing Valve), and L (Defrost board fault monitoring-Optional) on both the thermostat sub-base and unit low voltage terminal board. See Figures 13 - 16 and your heat pump thermostat installation manual for proper connections.

NOTE: Thermostats with a single "O/B" terminal for selection of reversing valve control must be configured for the "O" terminal to energize the reversing valve coil in the cooling mode of operation.

COPPER WIRE SIZE — AWG (1% Voltage Drop)				
Supply Wire Length-Feet				Supply Circuit Ampacity
200	150	100	50	
6	8	10	14	15
4	6	8	12	20
4	6	8	10	25
4	4	6	10	30
3	4	6	8	35
3	4	6	8	40
2	3	4	6	45
2	3	4	6	50
2	3	4	6	55
1	2	3	4	60

Wire Size based on N.E.C. for 60° type copper conductors.

Table 3. Copper Wire Size

Heating Configuration

This furnace is factory configured for two stage heat pump operation and as a 2 stage gas heating system when the thermostat is set to the Emergency Heat position.

Heat Pump Defrost Mode

The Ignition/Blower Control board has an Automatic Heat Staging jumper which can be repositioned to bring on the second stage of gas heat after a pre-determined delay in minutes that can be used to offset any cool air while the unit may be in a prolonged defrost cycle. This feature should only be used in applications where extreme outdoor coil icing may occur. Reposition the automatic heat staging jumper from factory setting "NONE" to 5 or 10 for the desired delay in minutes before the gas furnace will automatically move to high heat operation. See Figure 12B (page 30).

Checking Heat Anticipator Settings

- Add the current draw of the system components.
OR
- Measure the current flow on the thermostat **R-W** circuit after the circulating blower motor has started. Set the heat anticipator according to the thermostat manufacturer's instructions for heat anticipator settings.

Configuring the Variable Speed Blower

The variable speed blower has been designed to give the installer maximum flexibility for optimizing system performance, efficiency, and comfort. It is equipped with a microprocessor-controlled variable speed motor that is pre-programmed to deliver optimum airflow in a variety of conditions and system configurations. Because the blower can be configured in many ways, it is important to read and follow all instructions carefully.

CAUTION:

To avoid personal injury or property damage, make certain that the motor leads cannot come into contact with any uninsulated metal components of the unit.

Thermostat Wire Gauge	Recommended T-Stat Wire Length (Unit to T-Stat)	
	2-Wire (Heating)	5-Wire (Heating/Cooling)
24	55	25
22	90	45
20	140	70
18	225	110

Table 4. Thermostat Wire Gauge

Before operation, the variable speed blower must be configured to match the unit with the system, climatic conditions, and other system options. With the blower installed and configured properly, the furnace will gradually change speed in response to changes in system variables such as thermostat settings, duct static, filters, etc. The variable speed blower is configured by setting the heat, cool, and adjust jumpers located on the ignition control board as described below. See Figure 12B (page 30).

Selecting Cooling Airflow

The cooling airflow is selected by setting the Cool and Adjust jumpers on the ignition control board. Table 11 (page 27) lists the recommended airflow values (CFM) and selector tap settings for each nominal system capacity. All airflows for other modes of operation (except secondary gas heat) are determined by this basic setting. For maximum capacity, generally, a selection at or near the top of the CFM range for that nominal capacity is best.

NOTES:

- The CFM values listed in Table 11 are not dependent on duct static pressure. The motor automatically compensates (within the limits of the motor) for changes in duct static pressure.
- If coil icing occurs, the basic cooling airflow selected may be too low. Verify the selected setting is within the range shown in Table 11 and the system is properly charged. If icing continues, raise the selected airflow to the next higher tap.
- For maximum dehumidification and energy efficiency, select an airflow near the middle or bottom of the CFM range for that nominal capacity.
- The 2-stage cooling feature of the unit requires modulating the airflow. The unit will automatically adjust the airflow to the appropriate rate when the unit capacity changes.

Selecting Gas Heating Airflow

The heating airflow is selected by setting the heat jumper to the desired tap (A,B,C, or D) located on the ignition control board. Refer to Table 12 (page 27) and select a nominal rise based on the furnace's nominal efficiency and firing input. Follow across the table row to find the tap setting and nominal air-flow. Verify the selected rise is within the specification shown on the furnace rating label.

Delay Profile

The delay profile controls the start-up and shut-down characteristics of the packaged heat pump unit. By varying the start-up and shut-down characteristics of the packaged heat pump unit, the system can be optimized for energy efficiency, humidity control, and comfort.

The delay profile has a two-step ON delay. The blower will begin operation at 31% airflow for 30 seconds. The second step operation is 75% airflow for 30 seconds. After the two-step ON delay has been completed, the blower operation will be 100% until the thermostat has been satisfied. There is also a 60 second OFF delay at 50% airflow.

Demand Defrost Control

The demand defrost board controls the defrost cycle in response to ambient temperature, outdoor coil temperature and accumulated compressor run time. The heat pump is allowed to operate in the heating mode until the combination of outdoor ambient and outdoor coil temperatures indicate that defrosting is necessary, based on the programmed defrost curve. There are four preprogrammed defrost curves on the board.

- The defrost board is equipped with a 5 minute Anti-Short Cycle Delay (ASCD). The outdoor unit remains off for the 5 minute delay if the thermostat call is interrupted or there is a loss of power to the unit.
- A jumper pin is used to switch between the different curves. The default jumper position is curve 1 and is the recommended setting for most standard applications. See Table 5 for additional defrost curves settings.
- The factory default setting does not include a 30 second compressor delay function and has a 40 ° F defrost terminate temperature. If additional defrost time is needed, a higher terminate temperature is available by selecting a different demand curve. **NOTE:** The 30 second compressor delay function is optional and based on the demand curve selected.
- The standard defrost cycle will terminate after 13 minutes and 39 seconds or when the coil temperature reaches its terminate temperature, whichever occurs first.
- The control contains a forced - defrost feature, which places the system into defrost mode every 6 hours and 4 minutes, unless the coil temperature is above the selected terminate temperature.
- The system can be manually forced into defrost mode at any time by shorting the **TEST** terminals on the demand defrost board together for more than 9 seconds. The coil temperature sensor does not need to be cold when the unit is forced into defrost. After the **TEST** input

is removed, the defrost mode will terminate in 13.7 minutes, if the coil temperature is above the terminate set-point, or when the **Y** input is removed, whichever occurs first.

NOTE: If a demand curve is selected which has a 30 second compressor time delay in defrost, the delay is reduced to 10 seconds in TEST mode.

Ambient Sensor Mounting

For optimum performance of the heat pump system, the ambient sensor must be mounted on the outside of the unit. See Figure 6 (page 14).

1. Remove the mounting bracket wire tied to the control bracket and all hardware included in the packet.
2. Remove star bushing from 7/8" hole in corner panel of the unit. See Figure 7 (page 14).
3. Route the ambient sensor through the 7/8" hole in the corner panel of the unit, and then through the 7/8" hole in the mounting bracket.
4. Route the sensor through the star bushing. Use the star bushing to secure the mounting bracket to the unit.
5. Secure the ambient sensor inside the plastic clip and secure it to the mounting bracket with the screw and nut provided.
6. Install one spacer nut between the plastic clip and mounting bracket.
7. Bend the mounting bracket into position and screw the mounting bracket to the corner panel.

Optional Humidistat

An optional humidistat may be installed in the return air duct for humidity control (when needed), maximum system capacity and energy efficiency. The humidistat senses when humidity in the return air stream is above a preset level and sends a signal to the motor to reduce airflow. This allows more moisture to be removed until the humidity level drops. **NOTE:** The indoor blower motor of this packaged unit is pre-programmed for humidistat operation. Remove the **Red** jumper wire between the **R** and **DEHUM** terminals on the ignition control board.

If installing a humidistat, install it in the return air duct as directed in the installation instructions included with the kit. Wire the humidistat through the low-voltage wire entrance in the packaged unit to the screw terminals marked **R & DEHUM**. **Wire the humidistat to open on rise in humidity.**

When the HI/LO Dehumidify **Green** LED status light is ON, it signals Low Humidity and keeps 24V supplied to the motor for normal airflow requirements. If the humidity level of the conditioned space increases the humidistat will open. Loss of the 24V signal to the indoor blower motor allows the motor to reduce to approximately 75% of normal airflow selected until the humidity level drops. The **Green** LED is OFF during high humidity conditions. See Figure 12B (page 30).

Jumper Position	Minimum Time Between Defrosts (min)	Terminate Temperature (° F)	Compressor Delay Function
1	20	40	NO
2	20	40	YES
3	20	75	NO
4	20	75	YES

Table 5. Demand Defrost Curve Profiles

Check all factory wiring to the units wiring diagram. Inspect the factory wiring connections to be sure none loosened during shipping or installation.

Optional Comfort Alert™ Diagnostics Module

The Comfort Alert™ Diagnostics Module is a breakthrough innovation for troubleshooting heat pump and air conditioning system failures. The module installs easily in the electrical box of the outdoor unit near the compressor contactor. By monitoring and analyzing data from the Copeland scroll compressor and the thermostat demand, the module can accurately detect the cause of electrical and system related failures without any sensors. A flashing LED indicator communicates the ALERT code and a diagnostic key is also imprinted on the side of the module to quickly direct the technician to the root cause of a problem. See Figure 8.

NOTE: This module does not provide safety protection! The Comfort Alert™ Diagnostics Module is a monitoring device and cannot control or shut down other devices.

24 VAC Power Wiring

The Comfort Alert™ module requires a constant nominal 24 VAC power supply. The module should be powered by an R & C that doesn't have the potential for loss of power due to safety controls, defrost boards, or other control boards which could lead to nuisance alerts.

Thermostat Demand Wiring

The Comfort Alert module requires a two stage thermostat to operate properly. The Y2 thermostat wire entering the outdoor unit should be connected to the Y2 input on the unit terminal strip.

While the compressor is running, Comfort Alert will provide power to the second stage cooling solenoid inside the compressor after Y2 has been energized for 5 seconds. When the compressor is not running, Comfort Alert will not power the solenoid, regardless of the state of Y2. If Alert codes 1 or 9 appear while the compressor is running, Comfort Alert will turn off the solenoid to prevent solenoid damage from overheating conditions.

L Terminal Wiring

White-Rodgers Compatible Thermostats - The L connection is used to communicate Comfort Alert codes to compatible White-Rodgers thermostats. The L terminal of these thermostats should be connected to the Comfort Alert L terminal. See unit wiring diagram label included on the unit or in these instructions for correct field wiring connections.

NOTE: On some White-Rodgers compatible thermostats, an icon on the thermostat display will flash at the same rate as the Comfort Alert yellow Alert LED. An advanced option on these thermostats is to lock out the compressor when certain Alert codes are detected in indicating impending compressor damage. Refer to White-Rodgers thermostat manuals for more information.

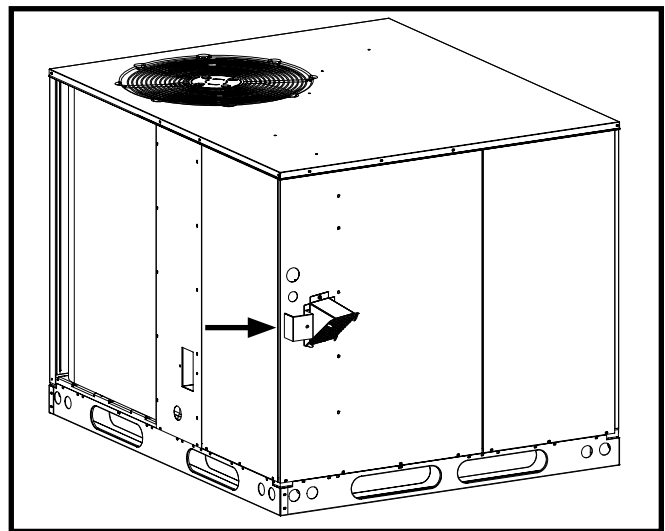

Figure 6. Ambient Sensor Location

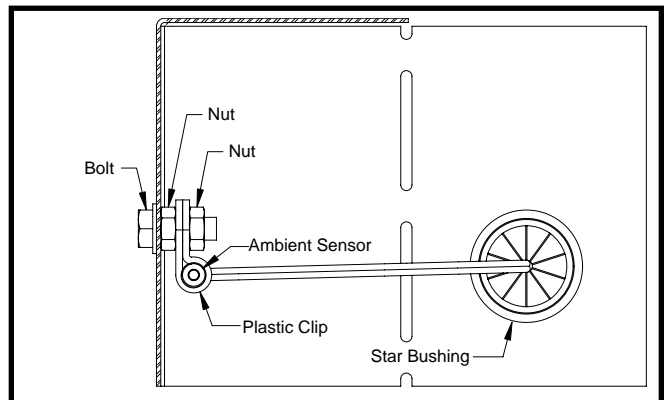

Figure 7. Ambient Sensor Mounting

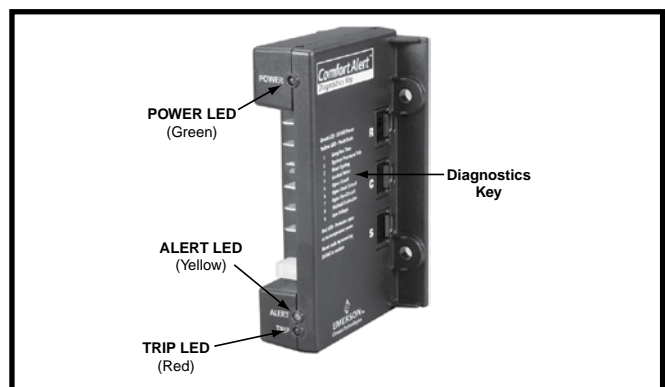

Figure 8. Comfort Alert™ Diagnostics Module

Standard Non-Compatible Thermostats – The L connection on non-compatible type thermostats are used for heat pump defrost control board fault monitoring. The L terminal of these thermostats should be connected directly to the defrost control board L terminal. See the wiring diagram label or the heat pump installation instructions for correct field wiring connections.

DC SOL Connection

The two pin DC SOL connector provides a connection to the Copeland UltraTech second stage compressor

solenoid (see Figure 12). This 24VDC solenoid is internal to the compressor and will not operate properly if 24VAC is applied to the compressor solenoid terminals.

To reduce the VA load of the solenoid on the system, Comfort Alert uses a phase control method to reduce the DC voltage to the solenoid to the minimum level required to keep the solenoid pulled in. As the 24VAC supply voltage varies, Comfort Alert intelligently changes the solenoid DC voltage supply to minimize power consumption. A voltmeter attached to the **DC SOL** output will measure 4-18VDC, when solenoid should be energized, depending on the level of the 24 VAC supply.

Interpreting the Diagnostic LED's

When an abnormal system condition occurs, the Comfort Alert™ module displays the appropriate ALERT and/or TRIP LED. The yellow ALERT LED will flash a number of times consecutively, pause and then repeat. To identify a Flash Code number, count the number of consecutive flashes. See Table 15 (pages 35 - 36) for flash code identification or Table 16 (page 37) for module wiring troubleshooting.

Each time the module powers up, the last ALERT Flash Code that occurred prior to shut down is displayed for one minute. The module will continue to display the LED until the condition returns to normal or if 24 VAC power is removed from the module.

LED Description

- **POWER LED (Green):** indicates voltage is present at the power connection of the module.
- **ALERT LED (Yellow):** communicates an abnormal system condition through a unique flash code. **NOTE:** The ALERT LED will flash consecutively, pause and then repeat the process. The number of consecutive flashes, referred to as the Flash Code, correlates to a particular abnormal condition. Detailed descriptions of these ALERT Flash Codes are listed in Table 15.
- **TRIP LED (Red):** indicates a demand signal is received from the thermostat, but current to the compressor is not detected by the module. The TRIP LED typically indicates if the compressor protector is open or the compressor has no power.

The scroll compressor's **R** (run), **C** (common), and **S** (start) wires are routed through the holes in the Comfort Alert™ module marked **R**, **C**, & **S**. **NOTE:** The common wire does not need to be routed through the module for it to operate.

Installation Verification

To verify the Comfort Alert is correctly installed, two functional tests can be performed.

1. Disconnect power from the compressor and force a thermostat call for cooling. **NOTE:** The Trip LED (red) should turn on indicating a compressor trip as long as 24VAC is measured at the **Y** terminal. If the Trip LED

does not function as described, refer to the wiring diagrams (Figures 14 or 16, pages 32 or 34).

2. Disconnect power from the compressor and 24VAC from Comfort Alert.
3. Remove the wire from **Y** terminal of Comfort Alert, reapply 24VAC power to Comfort Alert and reconnect power to the compressor.
4. Set the thermostat's system mode to COOL. **NOTE:** When the compressor starts to run, the Alert LED (yellow) will begin flashing a Code 8 indicating a welded contactor.
5. Disconnect power from the compressor and 24VAC from Comfort Alert.
6. With Comfort Alert OFF, reattach the wire to the **Y** terminal. Reapply power to compressor and 24VAC to Comfort Alert. **NOTE:** The Alert LED (yellow) will flash the previous code 8 for 1 minute and then turn off. If the yellow LED does not function, refer to the wiring diagrams (Figures 14 or 16).

Troubleshooting the Installation

Depending on system configuration, some ALERT Flash codes may not be active. The presence of safety switches affects how the system alerts are displayed by this module.

Resetting Alert Codes

Alert Codes can be reset manually and automatically. The manual method to reset an Alert code is to cycle the power to Comfort Alert off and on. For automatic reset, Comfort Alert continues to monitor the compressor and system after an Alert is detected. If conditions return to normal, the Alert code is turned off automatically.

Optional Outdoor Temperature Sensor

An outdoor temperature sensor can be installed in the field for use in conjunction with a compatible heat pump thermostat to convert heat pump mode of operation over to the gas heat system when outdoor conditions no longer favor operating the heat pump. Refer to the installation and operating instructions of the accessory kit for further information.

Grounding

WARNING:

The unit cabinet must have an uninterrupted or unbroken electrical ground to minimize personal injury if an electrical fault should occur. Do not use gas piping as an electrical ground!

This unit must be electrically grounded in accordance with local codes or, in the absence of local codes, with the National Electrical Code (ANSI/NFPA 70) or the CSA C22.1 Electrical Code. Use the grounding lug provided in the control box for grounding the unit.

GAS SUPPLY & PIPING

⚠ WARNING:

FIRE OR EXPLOSION HAZARD

- Failure to follow safety warnings exactly could result in serious injury or property damage.
- Installation and service must be performed by a qualified installer, service agency or the gas supplier.
- Do not store or use gasoline or other flammable vapors and liquids in the vicinity of this or any other appliance.

WHAT TO DO IF YOU SMELL GAS

- Do not try to light any appliance.
- Do not touch any electrical switch; do not use any phone in your building.
- Leave the building immediately.
- Immediately call your gas supplier from a neighbor's phone. Follow the gas supplier's instructions.
- If you cannot reach your gas supplier, call the fire department.

⚠ AVERTISSEMENT:

RISQUE D'INCENDIE OU D'EXPLOSION

- Le non-respect des avertissements de sécurité pourrait entraîner des blessures graves, la mort ou des dommages matériels.
- L'installation et l'entretien doivent être effectués par un installateur qualifié, un organisme de service ou le fournisseur de gazstaller, service agency or the gas supplier.
- Ne pas entreposer ni utiliser de l'essence ni d'autres vapeurs ou liquides inflammables dans le voisinage de cet appareil, ni de tout autre appareil.

QUE FAIRE S'IL Y A UNE ODEUR DE GAZ

- Ne pas tenter d'allumer aucun appareil.
- Ne toucher à aucun interrupteur électrique; n'utiliser aucun téléphone dans le bâtiment.
- Évacuer l'immeuble immédiatement.
- Appeler immédiatement le fournisseur de gaz en employant le téléphone d'un voisin. Respecter à la lettre les instructions du fournisseur de gaz.
- Si personne ne répond, appeler le service des incendies.

- All gas piping must be installed in compliance with local codes and utility regulations. In the absence of local codes the gas line installation must comply with the latest edition of the National Fuel Gas Code ANSI Z223.1 or CAN/CGA B149 Installation Codes.
- Some local codes require the installation of a manual main shut-off valve and ground joint union external to the furnace (Figure 9). The shut-off valve should be readily accessible for service and/or emergency use. Consult the local utility or gas supplier for additional requirements regarding placement of the manual main gas shut-off.
- The manifold pressure must be set to the appropriate value for your installation. Refer to the Manifold Pressure Adjustment section (page 19) for adjustment instructions.
- Gas piping must never run in or through air ducts, chimneys, gas vents, or elevator shafts.
- Compounds used to seal joints on gas piping must be resistant to the actions of LP propane gas.
- The main gas valve and main power disconnect to the furnace must be properly labeled by the installer in case emergency shutdown is required.
- An 1/8 inch NPT plugged tap must be installed in the gas line immediately upstream of the gas supply connection to the furnace for use when measuring the gas supply pressure. The plug should be readily accessible for service use.
- A drip leg should be installed in the vertical pipe run to the unit (Figure 9).

This unit only has right side gas entry. When connecting the gas, provide clearance between the gas supply line and the entry hole in the unit's casing to avoid unwanted noise and/or damage to the unit. A typical gas service hookup is shown in Figure 9.

Table 13 (page 28) lists gas pipe capacities for standard pipe sizes as a function of length in typical applications based on nominal pressure drop in the line.

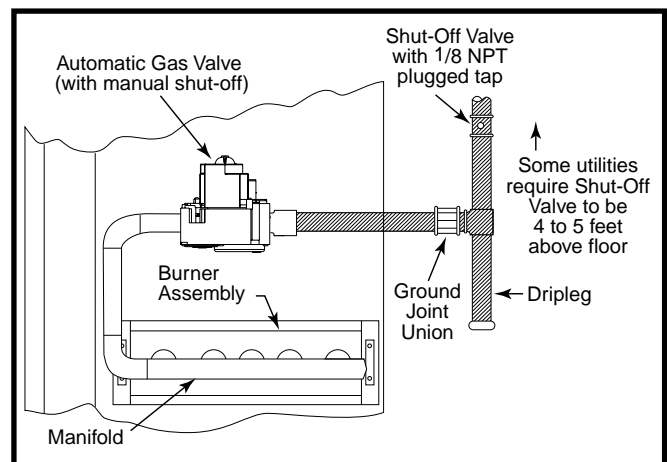

Figure 9. Typical Gas Hookup - Right Side Entry

Leak Check

WARNING:

FIRE OR EXPLOSION HAZARD

Failure to follow safety warnings exactly could result in serious injury or property damage.

Never test for gas leaks with an open flame. Use a commercially available soap solution made specifically for the detection of leaks to check all connections. A fire or explosion may result causing property damage, personal injury or loss of life.

AVERTISSEMENT:

RISQUE D'INDENNIE OU D'EXPLOSION

Le non-respect des avertissements de sécurité pourrait d'entraîner des blessures graves, la mort ou des dommages matériels.

Ne jamais utiliser une flamme nue pour vérifier la présence des fuites de gaz. Pour la vérification de tous les joints, utiliser plutôt une solution savonneuse commerciale fabriquée spécifiquement pour la détection des fuites de gaz. Un incendie ou une explosion peut entraîner des dommages matériels, des blessures ou la mort.

After the gas piping to the unit is complete, all connections must be tested for gas leaks. This includes pipe connections at the main gas valve, emergency shutoff valve and other gas connectors. A soap and water solution can be applied on each joint or union using a small paintbrush. If any bubbling is observed, the connection is not sealed adequately and must be retightened. Repeat the tightening and soap check process until bubbling ceases.

- **If pressure testing the gas supply lines at pressures greater than 1/2 psig (14 inches WC), the unit must be disconnected from the gas supply piping system to prevent damage to the gas valve.**
- **If the test pressure is less than or equal to 1/2 psig (14 inches WC), the unit must be isolated from the gas supply line by closing the manual shut-off valve.**

High Altitude Conversion

Conversion of this unit must be performed by qualified service personnel, using only approved parts. All installations must be made in accordance with the National Fuel Gas Code and/or local jurisdiction codes.

High altitude conversion can be field performed by a simple adjustment of manifold pressure or a change of the orifices (if necessary) as described on page 20. The changes required depend on the installation altitude and

the heating value of the gas (based on sea level) which can be obtained from your local gas utility. The heating value of gas at high altitude is always lower than the sea level heating value. The heating values listed in Tables 6 & 7 (page 20) are based on sea level values.

WARNING:

The reduction of input rating necessary for high altitude installation may only be accomplished with factory supplied orifices. Do not attempt to drill out orifices in the field. Improperly drilled orifices may cause fire, explosion, carbon monoxide poisoning, personal injury or death.

If installing this unit above 2,000 feet, the input rate must be reduced 4% per 1,000 feet of altitude (Example: 12% at 3,000 feet, 16% at 4,000 feet, etc). **NOTE:** Deration is necessary to compensate for low atmospheric pressure at high altitudes.

For altitudes between 5,000 and 10,000 feet above sea level, the unit can be converted by adjusting the furnace manifold pressure. See Tables 6 or 7 for the correct manifold pressure settings.

LP/Propane Gas Conversion

WARNING:

This unit was equipped at the factory for use with natural gas only. A special kit, supplied by the manufacturer, is required to convert the unit to operate on LP/Propane gas. Failure to use the proper conversion kit can cause fire, explosion, property damage, carbon monoxide poisoning, personal injury, or death.

Conversion of this equipment to LP/Propane gas must be made by qualified service personnel, using approved factory parts. Conversion to LP can be accomplished by replacing the natural gas orifices with the appropriate LP/Propane orifices and then adjusting the manifold pressure (page 20). Conversion to LP/Propane (sea level and high altitude) is detailed in the installation instructions provided with the conversion kit. **Please follow the instructions provided in each kit.** Approved conversion kits are:

- The United States LP/Propane Gas Sea Level and High Altitude Conversion Kit is for LP/propane conversion in the United States at altitudes between zero and 10,000 ft. above sea level.
- The Canadian LP/Propane Gas Sea Level and High Altitude Conversion Kit is for LP/Propane conversions in Canada at altitudes between zero and 4,500 ft. above sea level.

For installations between zero and 4,999 ft. above sea level, a #55 drill size orifice should be used. Installations 5,000 ft. above sea level require a # 56 drill size orifice.

Table 7 (page 20) lists the correct orifice size to use at different altitudes.

After changing the orifices, it is required that you measure the gas input rate by clocking the gas meter and using the local gas heating value. See Verifying and Adjusting the Firing Rate section on page 19.

START UP & ADJUSTMENTS

Pre-Start Check List

- √ Verify the unit is level and allows proper condensate drainage.
- √ Verify all clearance requirements are met and there is free airflow to and from the outdoor coil.
- √ Verify that the duct work is sealed to prevent air leakage.
- √ Verify that the line voltage power leads are securely connected and the unit is properly grounded.
- √ Verify that the low voltage wires are securely connected to the correct leads on the low voltage terminal strip.
- √ Verify that the gas line service pressure does not exceed 10.0 inches WC (0.36 psig), and is not less than 4.5 inches WC (0.16 psig) for natural gas. For LP gas the line service pressure must not exceed 14 inches WC (0.51 psig) and must not be less than 11.0 inches WC (0.40 psig).
- √ Verify that the flame roll-out control is closed. If necessary, press the red button to reset the control. **DO NOT** install a jumper wire across the control to defeat its function. If the control reopens upon start-up, **DO NOT** reset the control without identifying and correcting the fault condition which caused the control to trip.
- √ Verify that the gas line has been purged and all connections are leak tight.
- √ Verify that all exterior panels are replaced and securely fastened.
- √ Verify that the outdoor fan turns freely.
- √ Verify that the power supply branch circuit overcurrent protection is sized properly.
- √ Verify that the thermostat is wired correctly. The thermostat function switch should be set to OFF and the thermostat fan switch should be set to AUTO.

Start-Up Procedure

WARNING:

If this unit is equipped with crankcase heaters, allow 24 hrs for heating of the refrigerant compressor crankcase prior to start up and anytime the power has been removed for more than 12 hrs. Failure to comply may result in damage or cause premature failure of the system.

- Check all electrical wiring for loose connections and tighten as required.
- Check unit for return air filters and condensate trap.
- Close all electrical disconnects to energize the system.

Air Circulation

Leave the thermostat system mode on OFF and set the fan mode to ON. Blower will run continuously. Check the air delivery at the supply registers and adjust register openings for balanced air distribution. Examine ductwork for leaks or obstruction if insufficient air is detected. Set the thermostat fan mode to AUTO. The blower will stop running.

Short Cycle Protection

1. With the system operating in cooling mode, note the temperature setting of the thermostat and gradually raise the set-point temperature until the unit de-energizes.
2. Immediately lower the set point temperature of the thermostat to its original setting and verify that the indoor blower is energized.
3. After approximately 5 minutes, verify the compressor and fan energize and the temperature of the discharge air is cooler than the room temperature. **NOTE:** This is available only for the single phase models.

System Cooling Operation (2-Stage)

1. Set the thermostat's system mode to COOL and the fan mode to AUTO. Lower the thermostat temperature setpoint one degree below room temperature and verify the outdoor unit and blower energize on 1st stage cool.
2. Feel the air being circulated by the indoor blower and verify that it is cooler than ambient temperature. Listen for any unusual noises. If unusual sounds occur, determine the source of the noise and correct as necessary.
3. After determining the system is operating properly, wait 1-2 minutes and then lower the thermostat temperature set point an additional 3-4 degrees until the cooling system moves into 2nd stage or high cool operating mode. The compressor and indoor blower will increase in speed.
4. Allow the cooling system to operate for several minutes and then set the temperature selector above room temperature. Verify the fan and compressor cycle off with the thermostat. **NOTE:** The blower should also stop in approximately 60 seconds, unless the fan switch is set to the ON position.

System Heating (Heat Pump Mode)

1. Set the thermostat system mode to HEAT and the fan mode to AUTO. Raise the thermostat temperature set point one degree above room temperature and verify the outdoor unit and blower energize on 1st stage heat.
2. Feel the air being circulated by the indoor blower and verify that it is warmer than ambient temperature. Listen for any unusual noises. If unusual sounds occur, determine the source of the noise and correct as necessary.
3. After determining the system is operating properly, raise the thermostat temperature set point an additional 1-2 degrees until the system moves to 2nd stage heat pump mode of operation. The compressor and blower will increase in speed during 2nd stage cooling.

NOTE: If thermostat differential is set too high the gas heat system may energize (depending on thermostat model) and de-energize the heat pump outdoor system. Gas heat will remain in operation until the thermostat call for heat is satisfied.

4. Allow the heating system to operate for several minutes and then set the temperature selector below room temperature. Verify the system shutdown sequence. Note: The blower will remain operating for 60 or 150 seconds after the call for heat is removed depending on if the system was in heat pump or gas heat mode, respectively, unless the thermostat switch is set to the ON position.

Gas Heating (Emergency Heat Mode)

NOTE: When thermostat is set to the emergency heat position, heat pump operation will be locked out.

1. Set the thermostat to the lowest setting.
2. Follow the procedures given on the gas operating instruction label, in this installation instructions or attached inside the louvered control access panel.
3. Set the thermostat one degree above room temperature and verify the sequence of operation. See Operating Sequence section (page 21.)
4. Verify that the compressor and outdoor fan motor are not energized.
5. After determining the system is operating properly, wait 1-2 minutes and then raise the thermostat temperature set point an additional 1-2 degrees until the heating system moves into 2nd stage or high heat operating mode. The gas valve will energize to high heat mode while the induced draft motor and indoor blower motor both increase in speed.
6. After the unit has run for approximately five minutes, set the thermostat below room temperature. Verify the shutdown sequence; steps 10 -12 in the Operating Sequence section (page 22).

Verifying & Adjusting Temperature Rise

Verify the temperature rise through the unit is within the range specified on the unit data label for both high and low firing rates. Temperature rises outside the specified range could result in premature heat exchanger failure.

1. Place thermometers in the return and supply air stream as close to the unit as possible. The thermometer on the supply air side must be shielded against direct radiation from the heat exchanger to avoid false readings.
2. Adjust all registers and duct dampers to the desired position. Run the unit for 10 to 15 minutes before taking any temperature readings. The temperature rise is the difference between the supply and return air temperatures.

NOTE: For typical duct systems, the temperature rise will fall within the range specified on the data label (with the blower speed at the factory recommended setting) shown in Table 9 (page 27). If the measured temperature rise falls outside the specified range, it may be necessary to change

the blower speed. Lowering the blower speed increases the temperature rise and a higher speed decreases the temperature rise.

The unit is equipped with a variable speed motor. Heating and cooling speed selection is made by changing the tap settings on the ignition control board located in the unit control box. Refer to Configuring the Variable Speed Blower Section (page 12) for additional information.

The Variable Speed Blower (VSB) is designed with built in delay profiles for start up and shut down of the system. Refer to the Operating Sequence section (page 21) for more details.

Verifying & Adjusting Firing Rate

CAUTION:

Do not re-drill the burner orifices. If the orifice size must be changed, use only new orifices.

The firing rate must be verified for each installation to prevent over-firing of the furnace. **The firing rate must not exceed the rate shown on the unit data label.** To determine the firing rate, follow these steps:

1. Obtain the gas heating value (HHV) from the gas supplier.
2. Shut off all other gas fired appliances.
3. Start the unit in heating mode and allow it to run for at least 3 minutes.
4. Measure the time (in seconds) required for the gas meter to complete one revolution.
5. Convert the time per revolution to cubic feet of gas per hour using Table 14 (page 28).
6. Multiply the gas flow rate in cubic feet per hour by the heating value of the gas in Btu per cubic foot to obtain the firing rate in Btu per hour. See Example.
7. Adjust the manifold pressure if necessary. See Manifold Pressure Adjustment instructions on page 20. For additional information about elevations above 2,000 feet, see page 17.

Example:

- Time for 1 revolution of a gas meter with a 1 cubic foot dial = 40 seconds.
- From Table 14, read 90 cubic feet gas per hour.
- Local heating value of the gas (obtained from gas supplier) = 1,040 Btu per cubic foot.
- Input rate = 1,040 x 90 = 93,600 Btuh.

Verifying Over-Temperature Limit Control Operation

1. Verify the louvered control access panel is in place and that there is power to the unit.
2. Block the return airflow to the unit by installing a close-off plate in place of or upstream of the filter.
3. Set the thermostat above room temperature and verify the units operating sequence (page 21).

Manifold Pressure (in W.C.) for Natural Gas Installations			
Altitude above sea level	Heating Value Btu/cu. ft.		
	800 to 899	900 to 999	1,000 to 1,100
zero to 1,999 FT	3.5	3.5	3.5
2,000 to 4,999 FT	3.5	3.5	3.5
5,000 to 5,999 FT	3.5	3.5	3.0
6,000 to 7,999 FT	3.5	3.2	2.8
8,000 to 10,000 FT	3.0	2.8	2.5

Table 6. Manifold Pressure (in W.C.) for Natural Gas

NOTE: The over-temperature limit control should turn off the gas valve within approximately four minutes (exact time depends on the efficiency of the close-off when blocking the return air). The circulating air and combustion blowers should continue to run when the over-temperature limit control switch opens.

- Remove the close-off plate immediately after the over-temperature limit control opens. If the unit operates for more than four minutes with no return air, set the thermostat below room temperature, shut off power to the unit, and replace the over-temperature limit control.

Manifold Pressure Adjustment

The manifold pressure must be set to the appropriate value for your installation. To adjust the manifold pressure:

- Obtain the required manifold pressure setting. Use Table 6 for natural gas or Table 7 for LP/propane gas.
NOTE: The values listed in the tables are based on sea level values. At higher altitudes, the heating value of gas is lower than the sea level heating value.
- Remove the regulator cap. Turn the high fire adjusting screw clockwise to increase the pressure or counterclockwise to reduce the pressure. See Figure 10 (page 25) for adjusting screw locations.
- Replace the regulator cap after adjustments are complete.

Verifying Burner Operation

WARNING:

Uninsulated live components are exposed when louvered control access panel is removed.

- Remove the louvered control access panel and verify there is power to the unit.
- Set thermostat above room temperature and observe the ignition sequence. **NOTE:** The burner flame should carry over immediately between all burners without lifting off, curling, or floating. The flames should be blue, without yellow tips. Make sure the flame is drawn into the center of the heat exchanger tube. In a properly adjusted burner assembly, the flame bends down and to the right at the end of the heat exchanger tube. The end of the flame will be out of sight around the bend.
- After validating flame characteristics, set the thermostat below room temperature and verify the burner flame extinguishes completely.

Manifold Pressure (in W.C.) and Orifice Sizes for LP/Propane Gas Installations		
Altitude above sea level	Manifold Pressure	Orifice Size
zero to 1,999 FT	10.0	55
2,000 to 4,999 FT	8.5	55
5,000 to 5,999 FT	10.0	56
6,000 to 7,999 FT	9.0	56
8,000 to 10,000 FT	8.5	56

NOTE: Manifold pressure based on sea level LP heating value of 2,500 Btu/cu. ft.³

Table 7. Manifold Pressure (in W.C.) for LP Gas

Refrigerant Charging

WARNING:

These units are shipped fully charged with R-410A refrigerant and ready for installation. When a system is installed according to these instructions, no refrigerant charging is required. If repairs make it necessary for evacuation and charging, it should only be done by qualified, trained personnel thoroughly familiar with this equipment. Some local codes require licensed installation/service personnel to service this type of equipment. Under no circumstances should the owner attempt to install and/or service this equipment. Failure to comply with this warning could result in property damage, personal injury, or death.

CAUTION:

This unit uses R-410A refrigerant. DO NOT use any other refrigerant in this unit. Use of another refrigerant will damage the unit.

The system refrigerant charge can be checked and adjusted through the service ports provided at the front panel. Use only gauge lines which have a Schrader depression device present to actuate the valve. Refrigerant charging must be done by qualified personnel familiar with safe and environmentally responsible refrigerant handling procedures. Refer to the application notes and charging charts on pages 37 - 39

Charging an R-410A unit in AC mode at outdoor temperatures above 65F.

- With the system operating at steady-state, measure the liquid refrigerant pressure in psig at the service valve.
- Measure the liquid refrigerant temperature in Fahrenheit at the outlet of the condensor coil.
- For the temperature measured, determine the required liquid refrigerant pressure from the appropriate charging charts in Figures 18 - 21 (pages 38 & 39).

4. If the pressure measured in step 1 is greater than the required liquid refrigerant pressure determined in step 3, then there is too much charge in the system. Remove refrigerant and repeat steps 1 through 3 until the system is correctly charged.
5. If the pressure measured in step 1 is less than the required liquid refrigerant pressure determined in step 3, then there is too little charge in the system. Add refrigerant and repeat steps 1 through 3 until the system is correctly charged.

Charging an R-410A Unit in Heating Mode

1. Evacuate the refrigerant system.
2. Weigh in the proper charge based on the charge level noted on the rating plate. Unit charge **MUST** be verified in cooling season.
3. Verify the unit is operating properly as outlined in System Heating.

OPERATING SEQUENCE

The operating sequences for the heating, cooling, and fan modes are described below. Refer to the field and furnace wiring diagrams (Figures 14 - 17, pages 31 - 34).

2-Stage Heating Mode (Heat Pump)

1. On an initial call for heat, the thermostat closes and applies 24 VAC to terminals **G & Y1**. **NOTE:** This closes the compressor contactor and the compressor operates on first stage. The reversing valve is not energized in heating mode.
2. The control energizes the circulating blower at first stage for the selected air flow.
3. If the thermostat is not satisfied in the required time (based on the operation of the two-stage cooling thermostat), **Y2** will energize and the compressor will run in 2nd stage. Refer to the thermostat installation instructions for the heating profile.
4. When the thermostat is satisfied, terminals **G & Y** on the control board are de-energized, opening the compressor contactor.
5. If the thermostat does not satisfy on 2nd stage heat pump mode, the thermostat or outdoor sensor will call for the back-up gas heat. **NOTE:** If the unit is switching from heat pump to furnace, the outdoor fan and compressor will continue to run until flame ignition is detected in the furnace. The indoor blower will continue to run.

Gas Heating Mode - Emergency Heat & Defrost Mode

1. On a call for 1st stage heat, the thermostat closes and applies 24 VAC to terminal **W** on the control board.
2. Safety Circuit Proving - The control board verifies continuity through the 24VAC limit control circuit. If the high temperature limit switch and flame roll-out switch are closed and both the high and low vent pressure switches are open, the control board will then begin pressure switch proving. If an open limit is detected, the control board will energize the indoor blower motor and operate it continuously while the limit switch circuit is open. All other system functions will be inoperable until the limit circuit closes. While the limit circuit is open, the control will flash **1** on the red LED.

3. The furnace control checks for continuity (24 VAC) across the pressure switch. If the pressure switch is closed, the heat mode sequence will not continue. If it remains closed for 10 seconds, the red LED will flash 3 times repetitively until the fault condition clears.
4. Pressure Switch Proving - The control energizes the induced draft motor on High speed and waits for the low pressure vent switch to close. If the low pressure switch does not close within 60 seconds, the control will flash **2** on the red LED. If the low pressure switch does not close before 60 seconds expires, the control will de-energize the inducer for 60 minutes and continue to flash **2** during the 60 minute inducer off period. After the inducer has been off for 60 minutes, the control energizes the inducer motor and restarts the 60 second pressure switch proving period.
5. Pre-Purge - If the low pressure switch closes the control runs the inducer on high speed for a 30 second pre-purge time while monitoring the thermostat call for heat, limit switch circuit, low pressure switch, and flame sense. High pressure switch is ignored.
6. Igniter Warm Up - When the 30 second pre-purge time has elapsed, the control begins the Hot Surface Ignition (HSI) warm-up as follows:

Initial Power up: After 30 seconds of igniter warm-up, the gas valves (24 VAC) will open. The igniter circuit will stay energized for 3 seconds after the gas valve opens.

After Initial Power up: The control has a programmed adaptive ignition feature which varies the warm-up period as follows: If ignition is successful the warm-up is *reduced* by 3 seconds on each subsequent call for heat until ignition failure occurs. Upon ignition failure, the warm-up is *increased* by 3 seconds on the next try. If successful, the timing remains fixed at this level. In general, whenever ignition failure occurs the warm-up interval is increased by 3 seconds on the next try. And if successful, it remains there. Minimum and maximum warm-up time limits are set at 9 and 54 seconds.

7. Flame Proving / Ignition / Low Heat Operation - The furnace control must prove flame via the flame sensor 5 seconds after the low main gas valve is energized. If flame is sensed, burners are on and the igniter cools off. If no flame is sensed, the gas valve closes immediately and the inducer continues to run. A second trial for ignition (step 6) begins. If no flame is sensed on the fifth try for ignition, the furnace control is locked and the red LED will flash 4 times repetitively. The thermostat must be opened for at least ten seconds to reset the furnace control after a lock out. Otherwise, the furnace will attempt another ignition sequence in 1 hour.

Low Fire Heat (Stage 1): If flame is present at the end of the trial for ignition time, the control leaves Low main gas valve energized, inducer motor on High speed for the first 15 seconds, and begins the heat blower on delay. Control inputs are continuously monitored while the call for heat remains. The control will always energize the gas valve on Low fire with the inducer on high speed for

the first 15 seconds of any heating cycle and ignores any second stage heat demand. After this 15 second period, the control switches inducer to Low speed if no second stage demand is present, or attempts to stage to high heat if thermostat **W2** terminal is energized.

8. **Blower Start-Up** - After flame is proven, the furnace control energizes the circulating air blower at a very low speed. After 30 seconds, the blower will ramp to the airflow selected for heating.
9. **High Heat Staging** (with 2 Stage Heat Thermostat) - Unit will always start in low heat operation. See step 7 for start up sequence. After the initial 15 second start up sequence is satisfied, the control will wait for a W2 call from a 2-stage thermostat. After a second stage heat demand is present (W2 energized), the gas valve will open to High heat mode increasing the flow of gas to the burners while the inducer and blower motor ramp to high speed.
10. When the thermostat has been satisfied, gas valve is de-energized.
11. The inducer motor is de-energized after a 30 second post purge.
12. The circulating air blower will remain energized for approximately 120-150 seconds after the demand for heat is no longer present.
13. **Abnormal Conditions** - If a limit switch opens during heating operation the gas valve is de-energized immediately. The control de-energizes the induced draft motor and runs the indoor blower motor continuously while the limit switch is open.

2-Stage Cooling Mode

1. On a call for cooling the thermostat closes, applying 24 VAC to the **G**, **O** and **Y1** terminals on the control. This closes the compressor contactor, energizes the reversing valve, and the compressor operates on 1st stage.
2. The control energizes the circulating blower to 1/3 of the selected airflow for approximately 30 seconds.
3. The circulating blower will then ramp to approximately 3/4 of the selected airflow for another 30 seconds before adjusting to full airflow until the thermostat is satisfied.
4. If the thermostat is not satisfied in the required time, based on the operation of the two-stage cooling thermostat, **Y2** will energize and the compressor will run at second stage. Refer to the thermostat installation instructions for the cooling profile.
5. When the thermostat is satisfied, the **G**, **O** and **Y** terminals on the control board are de-energized opening the compressor contactor, and de-energizing the reversing valve.
6. The circulating air blower will operate at 1/2 of the selected speed for 60 seconds, and de-energize.

Fan Mode

1. On a call for fan operation, the thermostat applies 24 VAC to the **G** terminal on the furnace control board.
2. The circulating air blower ramps to 1/2 of the selected airflow.

EQUIPMENT MAINTENANCE

WARNING:

ELECTRICAL SHOCK, FIRE OR EXPLOSION HAZARD

Failure to follow safety warnings exactly could result in serious injury or property damage.

Improper servicing could result in dangerous operation, serious injury, death or property damage.

- **Before servicing, disconnect all electrical power to furnace.**
- **When servicing controls, label all wires prior to disconnecting. Reconnect wires correctly.**
- **Verify proper operation after servicing.”**

AVERTISSEMENT:

RISQUE DE CHOC ÉLECTRIQUE, D'INCENDIE OU D'EXPLOSION

Le non-respect des avertissements de sécurité pourrait entraîner un fonctionnement dangereux de l'appareil, des blessures graves, la mort ou des dommages matériels.

Un entreteïn incorrect pourrait entraîner un fonctionnement dangereux de l'appareil, des blessures graves, la mort ou des dommages matériels

- **Couper toute alimentation électrique au générateur d'air chaud avant de prodéder aux travaux d'entreteïn.**
- **Au moment de l'entreteïn des commandes, étiquetez tous les fils avant de les débrancher. S'assurer de les raccorder correctement.**
- **S'assurer que l'appareil fonctionne adéquatement après l'entreteïn.**

CAUTION:

Use care when removing parts from this unit. Personal injury can result from sharp metal edges present in all equipment of sheet metal construction.

Proper maintenance is important to achieve optimum performance from the system. The ability to properly perform maintenance on this equipment requires certain mechanical skills and tools. If you do not possess these skills, contact your dealer for maintenance. Consult your local dealer about the availability of maintenance contracts. Routine maintenance should include the following:

⚠ CAUTION:

The unit should never be operated without a filter in the return air system. Replace disposable filters with the same type and size.

- Inspect, clean or replace air filters at the beginning of each heating and cooling season, or more frequently if required.
- Inspect the condensate drain and outdoor coil at the beginning of each cooling season. Remove any debris. Clean the outdoor coil and louvers as necessary using a mild detergent and water. Rinse thoroughly with water.
- Inspect the electrical connections for tightness at the beginning of each heating and cooling season.
- The blower compartment should be cleaned monthly during the heating and cooling seasons to remove any dirt and lint that may have accumulated in the compartment or on the blower and motor. Buildup of dirt and lint on the blower and motor can create excessive loads on the motor resulting in higher than normal operating temperatures and possible shortened service life.
- Maintain heat exchanger and burners. The unit should operate for many years without excessive scale buildup in the heat exchanger, however, the heat exchanger, the vent system, and the burners should be inspected and cleaned (if required) by a qualified serviceman annually to ensure continued safe operation. Particular attention must be given to identify deterioration from corrosion or other sources.
- The motors for the circulating air blower, outdoor fan, and combustion blower are pre-lubricated at the factory. No further oiling is required for the life of this product.
- Inspect and clean the screen of the vent cover assembly at the beginning of each heating and cooling season.

Cleaning of Heat Exchanger

⚠ WARNING:

Holes in the heat exchanger can cause products of combustion to enter the home. Replace the heat exchanger if leaks are found. Failure to prevent products of combustion from being circulated into the living space can create potentially hazardous conditions including carbon monoxide poisoning that could result in personal injury or death.

If the heat exchanger must be cleaned due to soot or scale build up, follow the steps below.

1. Shut off the gas supply to the unit at the meter or at the manual valve in the gas supply piping.
2. Turn off all power to the unit and set the thermostat to the lowest temperature setting.

3. Remove the louvered access panel from the unit.
 4. Turn the gas control knob (gas valve) to the OFF position. See Figure 12 (page 29) for gas valve shut off instructions.
 5. Disconnect the wires from the gas valve, ignitor, flame sensor, combustion air motor, flame roll-out control, over-temperature limit switch, and pressure switch.
 6. Remove the silicone rubber tube from the collector pan to the pressure switch.
 7. Remove 4 nuts securing the combustion blower to the collector pan. Remove the combustion blower.
 8. Remove all screws securing the collector pan to the unit. Remove the collector pan from the unit.
-

⚠ CAUTION:

To prevent damage to the unit or internal components, it is recommended that two wrenches be used when loosening or tightening nuts. Do not over tighten!

9. Using 2 wrenches, separate the ground-joint union in the gas supply piping at the unit.
10. Remove the piping between the gas valve and the ground-joint union, if necessary.
11. Remove the screws that secure the burner assembly in place and the burner assembly. **BE EXTREMELY CAREFUL NOT TO DAMAGE THE IGNITOR WHILE REMOVING THE BURNER ASSEMBLY.**
12. Attach a round wire brush to a length of high grade stainless steel cable, such as drain clean-out cable. Attach the other end of the spring cable to a variable speed reversible drill. Slowly insert and rotate the cable into the top portion of the heat exchanger. Operate the drill alternating between forward and reverse, working the cable in and out several times to obtain sufficient cleaning. Repeat this process at each exchanger tube.
13. Remove all loosened debris from the heat exchanger tubes using high pressure air and vacuum cleaner.
14. Using a light, check the condition of the upper and lower sections of the heat exchanger tube.
15. Inspect the burners and if necessary, clean them carefully with a soft wire brush and/or the nozzle of a vacuum cleaner. **DO NOT DAMAGE THE IGNITOR OR FLAME SENSOR WHILE CLEANING THE BURNER.**
16. Replace all the parts in reverse order from which they were removed.
17. Follow the operating instructions found on the right side door and the User's Information Manual to return the unit to operation.

Cleaning of Burners

If the burners require cleaning, follow the steps below.

1. Shut off the gas supply to the unit either at the meter or at a manual valve in the supply piping.
2. Turn off all power to the unit and set the thermostat to the lowest temperature setting.
3. Remove the louvered control access panel from the unit.
4. Turn the gas control knob to the OFF position. See Figure 12 (page 29) for gas valve shut off instructions.
5. Disconnect the wires from the gas valve, ignitor, and flame sensor.



CAUTION:

To prevent damage to the unit or internal components, it is recommended that two wrenches be used when loosening or tightening nuts. Do not over tighten!

6. Using two wrenches, separate the ground-joint union in the gas supply piping at the unit.
7. Remove the piping between the gas valve and the ground-joint union (if applicable).
8. Remove all screws securing the burner assembly to the furnace.
9. Carefully remove the burner assembly from the furnace.
DO NOT DAMAGE THE IGNITER WHILE REMOVING THE BURNER ASSEMBLY.
10. Inspect the burners for accumulated dust or debris. If necessary carefully clean them with a soft wire brush and a vacuum cleaner. **DO NOT DAMAGE THE IGNITER WHILE CLEANING THE BURNER.**
11. Replace all the parts in reverse order from which they were removed.
12. Follow the lighting instructions found on the lower unit door to return the unit to operation.
13. Verify proper operation after servicing.

TROUBLESHOOTING

If the unit does not operate in the cooling mode, check the following:

- The thermostat is operating properly
- Electrical power to the unit is turned on
- The filters are not dirty
- The service doors are in place
- The 5 amp fuse is operational

If the unit does not operate in the heating mode, check the following:

- The thermostat is operating properly
- Electrical power to the unit is turned on
- The filters are not dirty
- The gas is turned on and the manual shut-off valve is open
- The service doors are in place
- The flame roll-out control is closed
- The diagnostic codes listed in Table 7 or on the wiring diagrams (Figures 14 - 17, pages 31 - 34).
- The 5 amp fuse is operational

SYSTEM STATUS - IGNITION	LED STATUS (RED)
Power On (Normal Operation)	ON
High Limit Circuit Open	1 Flash
Pressure Switch Open with Inducer On	2 Flashes
Pressure Switch Closed with Inducer Off	3 Flashes
Failed Ignition (5 attempts) - Control in 1 Hour Lockout	4 Flashes
208-230 Volt Polarity Issue	5 Flashes
Excess High limit trips (5) within one call for heat	6 Flashes
Excess pressure switch cycles (5) within one call for heat	7 Flashes
Excess flame dropouts (5) within one call for heat	8 Flashes
Not Used	9 Flashes
Flame present with gas valve Off	10 Flashes

SYSTEM STATUS - 2nd STAGE HEAT DEMAND	LED STATUS (GREEN)
No demand for 2nd stage heat	OFF
2nd stage heat demand (Normal operation)	ON
2nd stage heat demand, high pressure switch not closed	Flashing

SYSTEM STATUS - HI/LO DEHUMIDIFY (Cooling Mode only)	LED STATUS (GREEN)
Factory jumper wire "R" to "DEHUM" in place or "Close on Fall" humidistat (Low humidity) - Closed	ON
Humidistat open (High Humidity) Low Speed Blower call	OFF

SYSTEM STATUS - CFM	LED STATUS (YELLOW)
NOT USED	OFF

Table 8. Ignition / Blower Control Diagnostic Codes

COMPONENT FUNCTIONS

Comfort Alert™ Diagnostics -The Comfort Alert diagnostics module troubleshoots heat pump and air conditioning system failures and accurately detects the cause of electrical and system related failures without any sensors. A flashing LED indicator communicates the ALERT code to quickly direct the technician to the root cause of a problem.

Flame Roll-Out Control - The flame roll-out control acts to verify that the burner flame is being drawn into the heat exchanger tubes. If the burner flame is not being drawn into the heat exchanger tubes, the roll-out control will open within several seconds and the integrated control diagnostic light will flash one time. If the limit opens, the integrated control diagnostic will flash one time. The circulating air blower will continue to operate while the flame roll-out control is open.

Flame Sensor - The flame sensor acts to prove that flame has carried over from the ignitor to the right-most burner. If no flame is sensed, the unit will be shut down automatically.

Dual Pressure Switch - The dual pressure switch verifies that the inducer motor is drawing the combustion gases through the heat exchanger tubes and venting the gases through the vent system for both high and low fire conditions.

Gas Valve - The gas valve controls the flow of gas to the burners in both low and high fire. When the gas valve is energized it automatically opens and regulates the gas pressure in the manifold. See Figure 10 below.

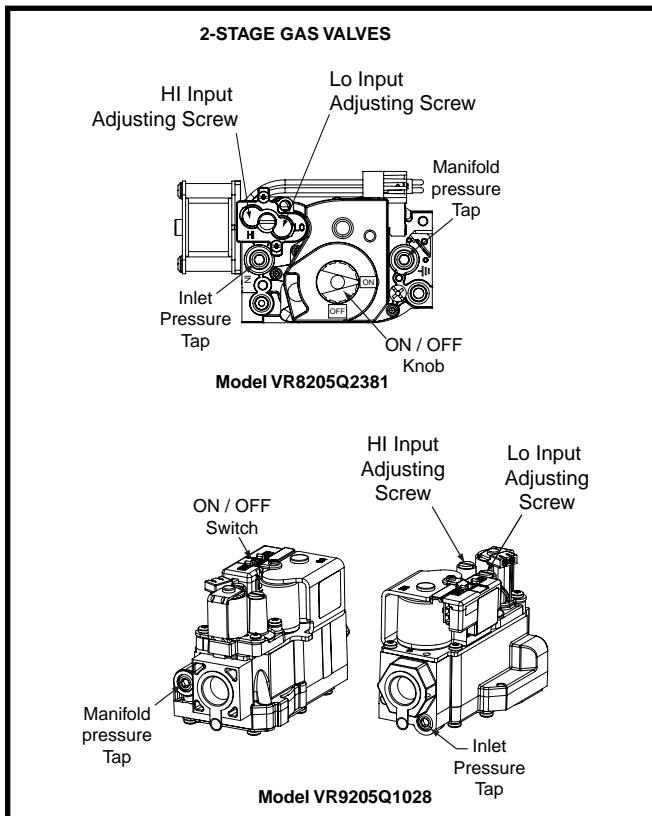

Figure 10. HI & LO Input Adjusting Screws

Over-Temperature Limit Control - The over-temperature limit control prevents the air temperature leaving the unit from exceeding the maximum outlet air temperature. If the limit opens, the integrated control diagnostic will flash one time. The circulating air blower will continue to operate while the over-temperature limit control is open.

REPLACEMENT PARTS

Replacement parts are available through all Nordyne distributors. Please have the complete model and serial number of the unit when ordering replacement parts.

Electrical:

- Capacitors
- Compressors
- Contactors
- Defrost Control Board
- Gas Valves
- Ignition Controls
- Ignitors/Flame Sensors
- Pressure Switches
- Relays
- Reversing Valve Solenoid
- Temperature Limit Switches
- Thermostats
- Time Delay Relays
- Transformers

Motors:

- Blower Motor
- Fan Motor
- Inducer Blower Motor

Components:

- Blower Assembly
- Burner Manifold
- Burners/Orifices
- Cabinet Panels
- Expansion Valves
- Fan Grille
- Filter/Driers
- Gaskets
- Heat Exchanger
- Reversing Valve

FIGURES & TABLES

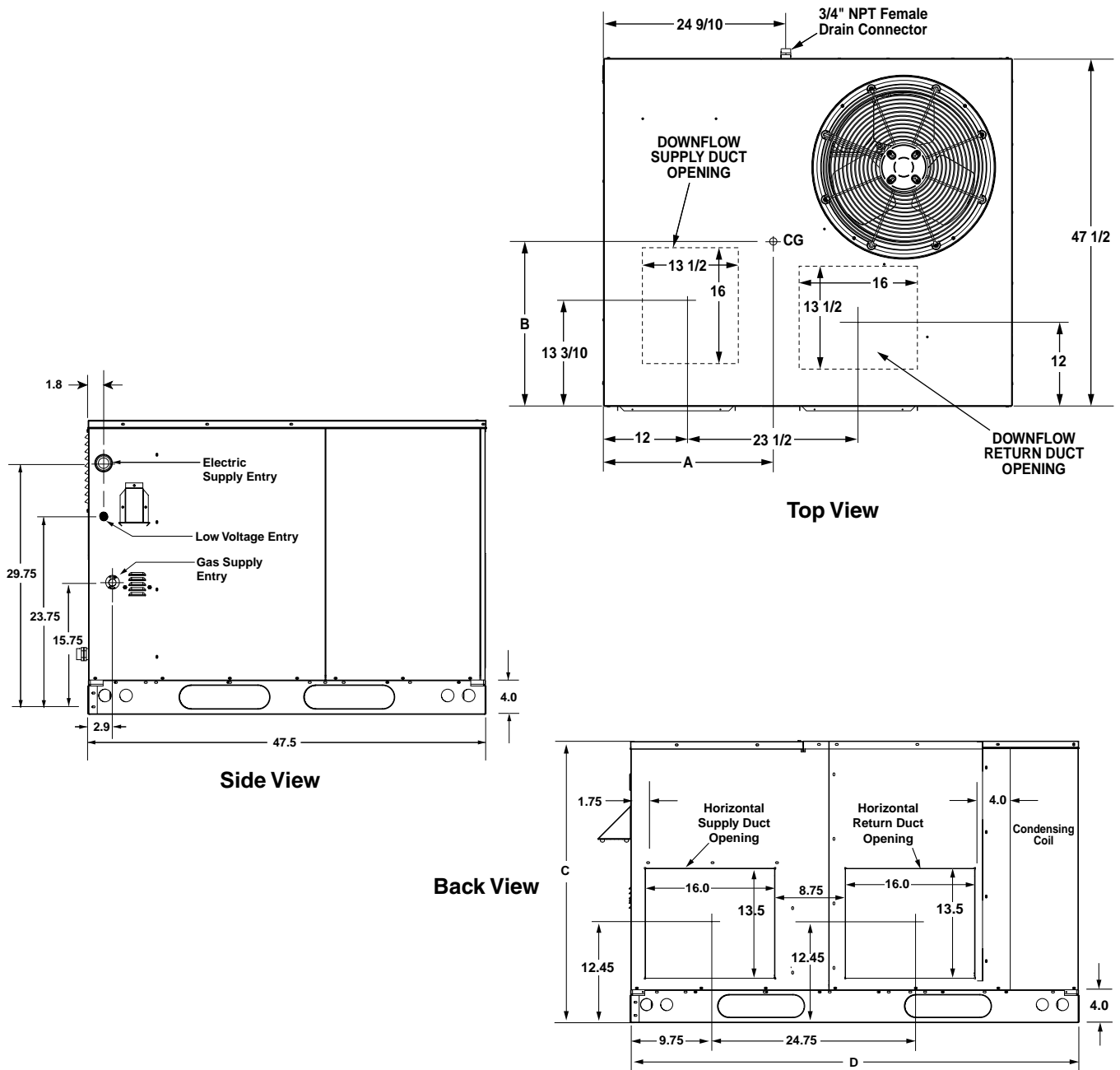

Figure 11. Unit Dimensions

Model Number	Unit Weight	Center of Gravity		Height (in inches)		D
		A	B	C		
				with base rails	without base rails	
X24K080CA	480	26.0	27.0	39.0	35.3	55.8
X36K100CA	599	27.0	26.5	39.0	35.3	55.8
X48K120CA	618	27.0	26.5	47.0	43.3	55.8
X60K120CA	655	30.0	26.5	47.0	43.3	63.6*

*Extended base pan models use same roof curb as 2 - 4 ton units.

Table 9. Center of Gravity & Unit Shipping Weights

AIRFLOW INFORMATION

Model Number	Heating Input (Btuh)	Heating Output (Btuh)	CFM Range	Heating Rise Range (°F)	Cooling Output (Btuh)	Blower Size	Motor (HP)
X24K080CA	80,000	64,000	1100 - 1350	35-65	24,000	10 X 10	1/2
	52,000	41,600	750 - 1050				
X36K100CA	100,000	80,000	1200 - 1600	40-70	35,000	10 X 10	1/2
	65,000	52,000	900 - 1200				
X48K120CA	120,000	96,000	1350 - 2000	40-70	46,000	11 X 10	1
	78,000	62,400	950 - 1300				
X60K120CA	120,000	96,000	1350 - 2000	40-70	55,500	11 X 10	1
	78,000	62,400	950 - 1300				

NOTE: CFM and Rise are independent of ESP in a variable speed blower.

Table 10. Nominal Airflow Rates & Temperature Rises (° F)

2 TON UNITS				3 TON UNITS				4 - 5 TON UNITS				
BLOWER SELECTOR SETTING		RECOMMENDED A/C AIRFLOW RATE (CFM)		BLOWER SELECTOR SETTING		RECOMMENDED A/C AIRFLOW RATE (CFM)		BLOWER SELECTOR SETTING		RECOMMENDED A/C AIRFLOW RATE (CFM)		
COOL	ADJUST			COOL	ADJUST			COOL	ADJUST			
TAP "A"	-10%	2 TON	685	TAP "A"	-10%	3 TON	840	TAP "A"	-10%	4 TON	5 TON	1485
	Normal		760		Normal		930		Normal			1650
	+10%		835		+10%		1025		+10%			1815
-10%	840		-10%	975	-10%		1620					
TAP "B"	Normal	930	TAP "B"	Normal	1080	TAP "B"	Normal	1800				
	+10%	1025		+10%	1190		+10%	1980				
	-10%	975		-10%	1110		-10%	1665				
TAP "C"	Normal	1080	TAP "C"	Normal	1230	TAP "C"	Normal	1850				
	+10%	1190		+10%	1350		+10%	2035				
	-10%	1110		-10%	1290		-10%	1800				
TAP "D"	Normal	1230	TAP "D"	Normal	1430	TAP "D"	Normal	2000				
	+10%	1350		+10%	1575		+10%	2200				

Table 11. Airflow Settings for Cooling

Blower HEAT Selector Setting	2 TON				3 TON				4 & 5 TON			
	Low Input		High Input		Low Input		High Input		Low Input		High Input	
	52,000		80,000		65,000		100,000		78,000		120,000	
	CFM	Rise	CFM	Rise	CFM	Rise	CFM	Rise	CFM	Rise	CFM	Rise
TAP "A"	750	51	1100	55	900	53	1200	63	950	61	1350	67
TAP "B"	850	45	1150	53	1000	48	1300	58	1050	55	1500	61
TAP "C"	950	41	1250	49	1100	44	1400	54	1150	50	1700	54
TAP "D"	1050	37	1350	45	1200	40	1600	47	1300	44	2000	46

NOTES:

1. Recommended temperature rises are highlighted in **bold**. Use of any other setting may result in nuisance trips.
2. Temperature rises in the table are approximate. Actual temperature rises may vary.
3. Blower "ADJUST" tap non-functional in Heating mode.

Table 12. Airflow Settings (CFM) & Rise (° F) for Heating Operation Mode

GAS INFORMATION

GAS PIPE CAPACITIES								
Nominal Pipe Diameter (IN.)	Length of Pipe Run (Feet)							
	10	20	30	40	50	60	70	80
1/2	130	90	75	65	55	50	45	40
3/4	280	190	150	130	115	105	95	90
1	520	350	285	245	215	195	180	170
1 1/4	1,050	730	590	500	440	400	370	350
1 1/2	1,600	1,100	890	760	670	610		

$\text{Cubic Feet Per Hour Required} = \frac{\text{Input To Furnace (Btu/hr)}}{\text{Heating Value of Gas (Btu/Cu. Ft.)}}$
--

NOTE: The cubic feet per hour listed in the table above must be greater than the cubic feet per hour of gas flow required by the furnace. To determine the cubic feet per hour of gas flow required by the furnace, divide the input rate of the furnace by the heating value (from gas supplier) of the gas.

**Table 13. Capacity of Black Iron Gas Pipe (cu. ft. per hour)
for Natural Gas w/ Specific Gravity = 0.60**

GAS FLOW RATES			
TIME FOR ONE REVOLUTION (SECONDS)	CUBIC FEET PER REVOLUTION OF GAS METER		
	1	5	10
10	360	1,800	3,600
12	300	1,500	3,000
14	257	1,286	2,571
16	225	1,125	2,250
18	200	1,000	2,000
20	180	900	1,800
22	164	818	1,636
24	150	750	1,500
26	138	692	1,385
28	129	643	1,286
30	120	600	1,200
32	113	563	1,125
34	106	529	1,059
36	100	500	1,000
38	95	474	947
40	90	450	900
42	86	429	857
44	82	409	818
46	78	391	783
48	75	375	750
50	72	360	720
52	69	346	692
54	67	333	667
56	64	321	643
58	62	310	621
60	60	300	600
62	58	290	581
64	56	281	563

GAS FLOW RATES			
TIME FOR ONE REVOLUTION (SECONDS)	CUBIC FEET PER REVOLUTION OF GAS METER		
	1	5	10
66	55	273	545
68	53	265	529
70	51	257	514
72	50	250	500
74	49	243	486
76	47	237	474
78	46	231	462
80	45	225	450
82	44	220	439
84	43	214	429
86	42	209	419
88	41	205	409
90	40	200	400
92	39	196	391
94	38	191	383
96	38	188	375
98	37	184	367
100	36	180	360
102	35	176	353
104	35	173	346
106	34	170	340
108	33	167	333
110	33	164	327
112	32	161	321
114	32	158	316
116	31	155	310
118	31	153	305
120	30	150	300

Table 14. Gas Flow Rates

FOR YOUR SAFETY READ BEFORE OPERATING

WARNING: If you do not follow these instructions exactly, a fire or explosion may result causing property damage, personal injury, or loss of life.

- A. This appliance does not have a pilot. It is equipped with an ignition device which automatically lights the burner. Do not try to light the burner by hand.
- B. BEFORE OPERATING smell all around the appliance area for gas. Be sure to smell next to the floor because some gas is heavier than air and will settle on the floor.
- WHAT TO DO IF YOU SMELL GAS
- Do not try to light any appliance.
 - Do not touch any electrical switch; do not use any phone in your building.
 - Immediately call your gas supplier from a neighbor's phone. Follow the gas supplier's instructions.
 - If you cannot reach your gas supplier, call the fire department.
- C. Use only your hand to push in or turn the gas control knob. Never use tools. If the knob will not push in or move by hand, do not try to repair it, call a qualified service technician. Force or attempted repair may result in a fire or explosion.
- D. Do not use this appliance if any part has been under water. Immediately call a qualified service technician to inspect the appliance and to replace any part of the control system and any gas control which has been under water.

POUR VOTRE SÉCURITÉ. À LIRE AVANT L'EMPLOI

ATTENTION! L'observation de ces instructions peut entraîner un incendie ou une explosion pouvant causer des dommages à votre propriété à votre personne, ou la mort.

- A. Cet appareil ménager n'a pas de veilleuse. Il est doté d'un système d'allumage automatique. Ne pas essayer d'allumer le brûleur manuellement.
- B. AVANT L'USAGE. Attention à une possible odeur de gaz surtout au niveau du plancher où les gaz les plus lourds ont la tendance de se concentrer.
- EN CAS D'ODEUR DE GAZ.
- Ne mettre en marche aucun appareil électrique.
 - Ne toucher à aucun commutateur électrique, ne pas employer le téléphone.
 - Quitter le bâtiment immédiatement et avvertir la compagnie du gaz en utilisant le téléphone d'un voisin.
 - A défaut de la compagnie du gaz, avvertir le service des pompiers.
- C. Enfoncer ou faire tourner le robinet à gaz à la main seulement. Ne jamais utiliser d'outils. S'il n'est pas possible de faire tourner ou d'enfoncer le robinet à la main, ne pas essayer de le réparer. Faire appel à un spécialiste. Forcer ou tenter de réparer le robinet pourrait être à l'origine d'une explosion ou d'un incendie.
- D. Il est déconseillé d'utiliser cet appareil en contact prolongé avec l'eau. Faire inspecter ou remplacer toute commande par un technicien qualifié si un des systèmes de contrôle du gaz s'est trouvé sous l'eau.

OPERATING INSTRUCTIONS

1. **STOP!** Read the safety information above on this label.
2. Set the thermostat to the lowest setting.
3. Turn off all electrical power to the appliance.
4. The appliance's ignition device automatically lights the burner. Do not try to light burner by hand.
5. Remove the control access door/panel (upper door if two-door model).
6. Move the gas control switch to the "OFF" position. (See Figure 1)
7. Wait five (5) minutes to clear out any gas. Then smell for gas, including near the floor. If you smell gas, STOP! Follow "B" in above information. If you don't smell gas, go to the next step.
8. Move the gas control switch to the "ON" position. (See Figure 1)
9. Replace the control access door/panel (upper door if two-door model).
10. Turn on all electrical power to the appliance.
11. Turn the thermostat to a desired setting.
12. If the appliance will not operate, follow the instructions "To Turn Off Gas To Appliance" and call your service technician or gas supplier.

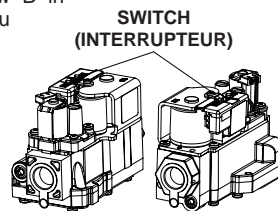

Figure 1

MODE D'EMPLOI

1. **ATTENTION!** Lire d'abord la liste des mesures de sécurité ci-dessus.
2. Mettre le thermostat à la position minimale.
3. Couper le courant électrique qui mène à l'appareil.
4. Cet appareil ménager étant doté d'un système d'allumage automatique, ne pas essayer d'allumer le brûleur manuellement.
5. Retirer le panneau/volet d'accès de commande (panneau supérieur s'il s'agit d'un modèle à deux panneaux).
6. Réglez l'interrupteur de commande du gaz à la position "OFF". (voir Figure 1).
7. Attendre cinq (5) minutes pour s'assurer de la dissipation du gaz. En cas d'odeur, ARRÊTER LE PROCÉDÉ. Suivre les instructions ci-dessus (Section B). En l'absence de toute odeur de gaz, avancer à l'étape suivante.
8. Réglez l'interrupteur de commande du gaz à la position "ON". (voir Figure 1).
9. Remettre le panneau/volet d'accès de commande en place (panneau supérieur s'il s'agit d'un modèle à deux panneaux).
10. Rebrancher l'appareil sur le réseau électrique.
11. Ajuster le thermostat à la position désirée.
12. Si l'appareil ne fonctionne pas, suivre les "Directives d'arrêt" cidessous et appeler le technicien de service.

TO TURN OFF GAS TO APPLIANCE

1. Set the thermostat to the lowest setting.
2. Turn off all electrical power to the appliance if service is to be performed.
3. Remove the control access door/panel (upper door if two-door model).
4. Move the gas control switch to the "OFF" position. Do not use force. (See Figure 1)
5. Replace the control access door/panel (upper door if two-door model).



Figure 12. Gas Valve Label

DIRECTIVES D'ARRÊT

1. Mettre le thermostat à la position minimale.
2. Débrancher l'appareil en prévision de la réparation.
3. Retirer le panneau/volet d'accès de commande (panneau supérieur s'il s'agit d'un modèle à deux panneaux).
4. Réglez l'interrupteur de commande du gaz à la position "OFF". Ne forcez pas. (voir Figure 1).
5. Remettre le panneau/volet d'accès de commande en place (panneau supérieur s'il s'agit d'un modèle à deux panneaux).

7111710 (04/11)

WIRING DIAGRAMS

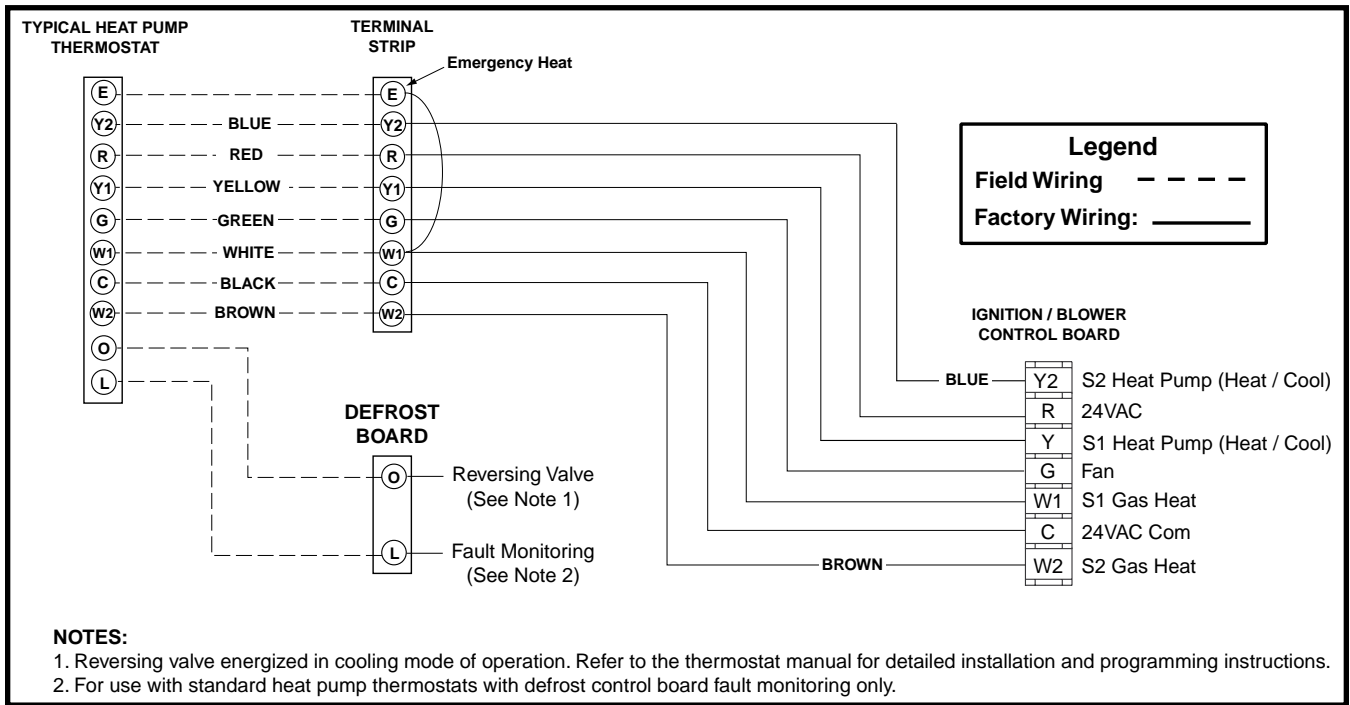

Figure 13A. Thermostat Connection for Two Stage Heating / Two Stage Cooling Configuration

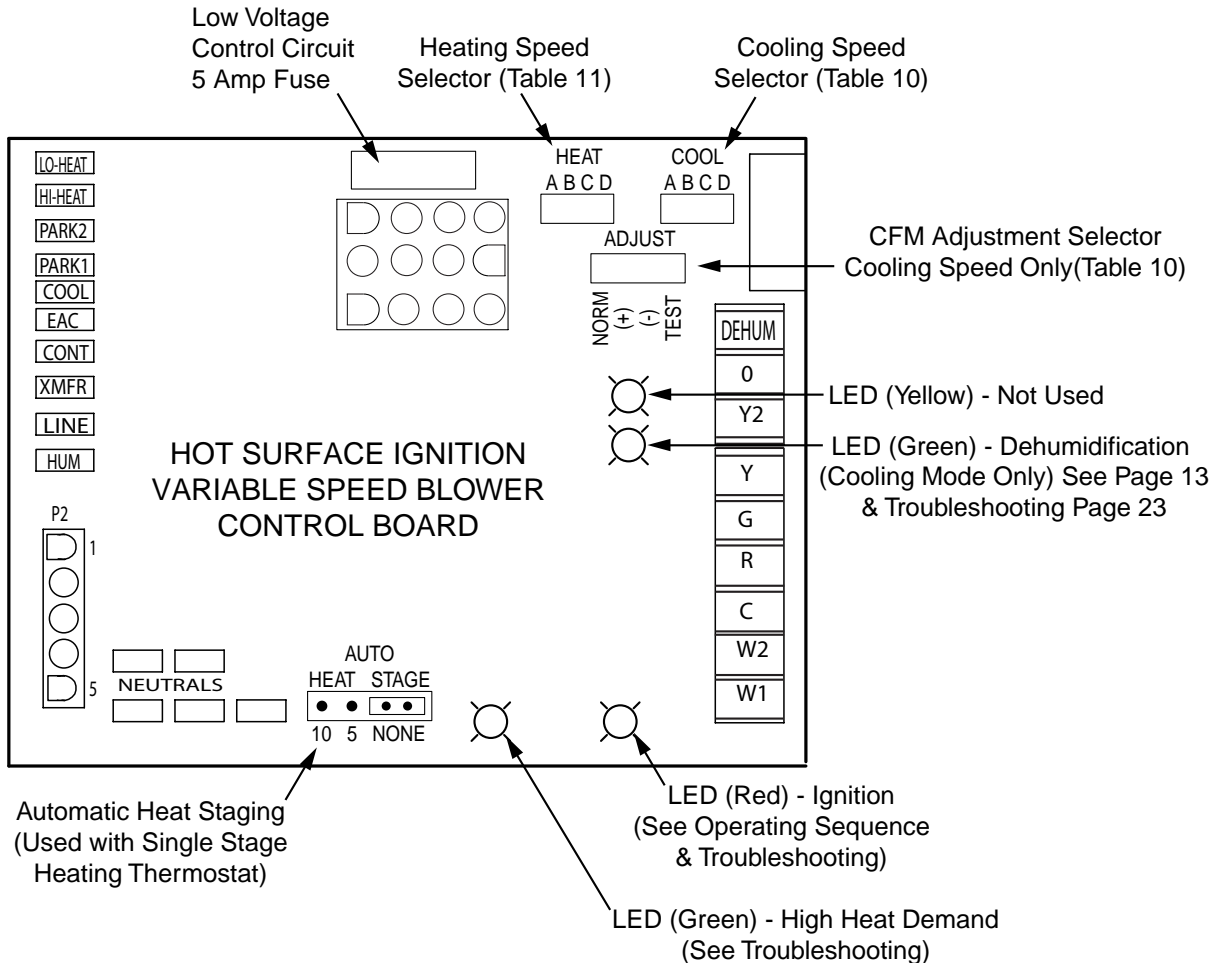

Figure 13B. Two-Stage, Hot Surface Ignition & Blower Control Board

WIRING DIAGRAM

Dual Fuel Heating and Cooling Packaged System

208/230 Volt

Single Phase / 60 Hz.

NOTES:

1. Disconnect power before servicing.
2. For supply connections use copper conductors only.
3. Not suitable on systems that exceed 150V to ground.
4. If any of the original wire as supplied with the furnace must be replaced, it must be replaced with wiring material having a temperature rating of at least 105°C.

5. For supply wire ampacities and overcurrent protection, see unit rating plate.
6. Ensure that wires from the blower remain connected to the board thermostat terminals after making the field thermostat connections.
7. A heat pump thermostat with fossil fuel back-up heat capability is REQUIRED for this system.

1. Couper le courant avant de faire le rétrolien.
2. Employez uniquement des conducteurs en cuivre.
3. Ne convient pas aux installations de plus de 150 V à la terre.

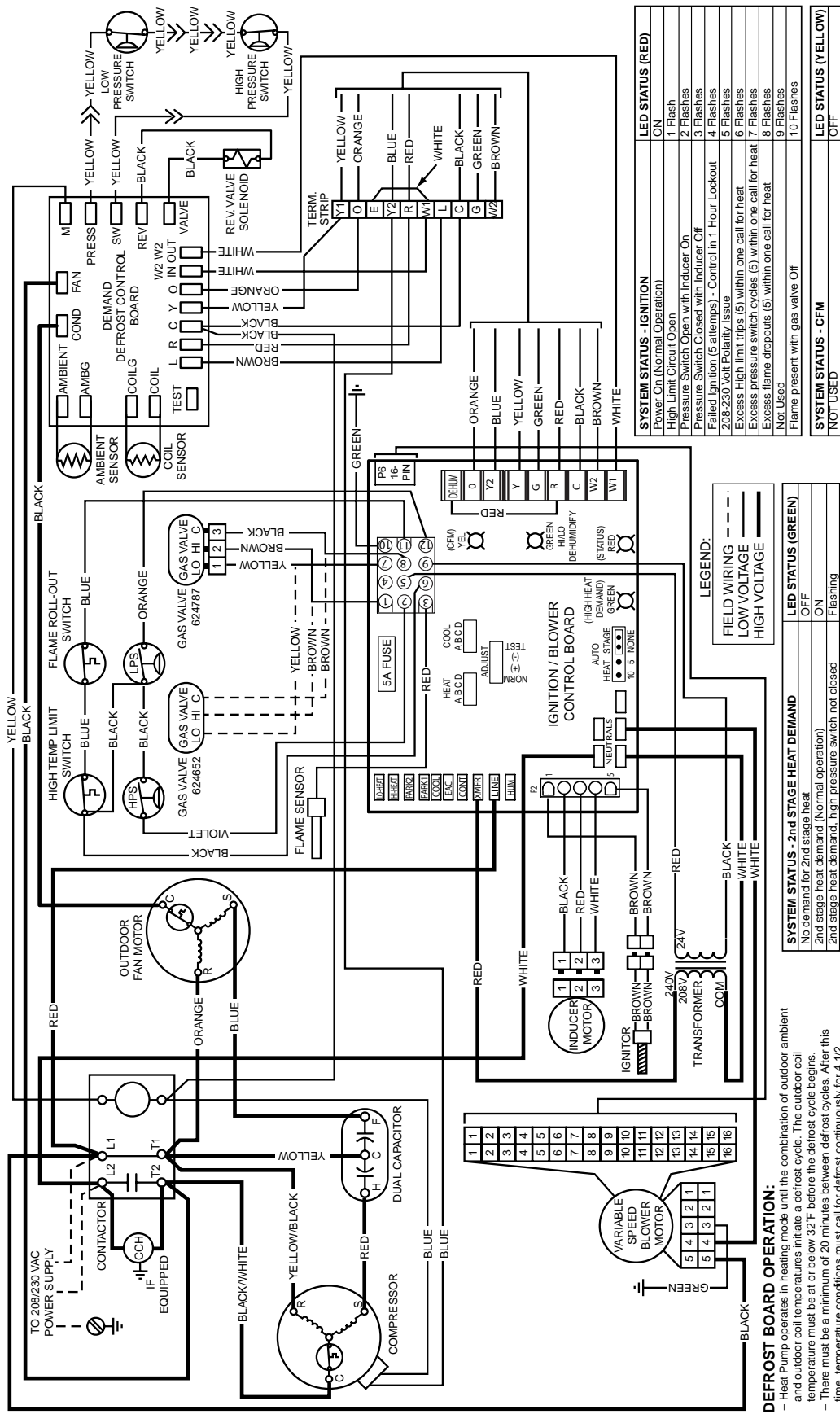

DEFROST BOARD OPERATION:

- Heat Pump operates in heating mode until the combination of outdoor ambient and outdoor coil temperatures initiate a defrost cycle. The outdoor coil temperature must be at or below 32 F before the defrost cycle begins.
- There must be a minimum of 20 minutes between defrost cycles. After this time, temperature conditions must call for defrost continuously for 4 1/2 minutes before a defrost cycle is initiated.
- The defrost cycle ends when either the outdoor coil temperature sensor reaches the defrost terminate set point, or 13 minutes, 39 seconds of compressor run time has elapsed with the control in the defrost mode. (See installation instructions for available terminate temperatures and their specific jumper location)

SYSTEM STATUS - 2nd STAGE HEAT DEMAND	LED STATUS (GREEN)
No demand for 2nd stage heat	OFF
2nd stage heat demand (Normal operation)	ON
2nd stage heat demand, high pressure switch not closed	Flashing

SYSTEM STATUS - HI/LO DEHUMIDIFY (Cooling Mode only)	LED STATUS (GREEN)
Factory jumper wire "R" to "DEHUM" in place or "Close on Fail" humidistat (Low humidity) - Closed Humidistat open, (High Humidity) Low Speed Blower call	ON
	OFF

SYSTEM STATUS - IGNITION	LED STATUS (RED)
Power On (Normal Operation)	ON
High Limit Circuit Open	1 Flash
Pressure Switch Open with Inducer On	2 Flashes
Pressure Switch Closed with Inducer Off	3 Flashes
Failed Ignition (5 attempts) - Control in 1 Hour Lockout	4 Flashes
208/230 Volt Polarity Issue	5 Flashes
Excess high limit trips (5) within one call for heat	6 Flashes
Excess pressure switch cycles (5) within one call for heat	7 Flashes
Excess flame dropouts (5) within one call for heat	8 Flashes
Not Used	9 Flashes
Flame present with gas valve Off	10 Flashes

SYSTEM STATUS - CFM	LED STATUS (YELLOW)
NOT USED	OFF

7111840
(Replaces 711137A)
11/11

Figure 14. Two-Stage Cool, Two Stage Heat (Heat Pump)
Two-Stage Gas Heating (2 & 5 Ton Only)

WIRING DIAGRAM

Dual Fuel Heating and Cooling Packaged System

208/230 Volt

Single Phase / 60 Hz.

NOTES:

1. Disconnect power before servicing.
2. For supply connections use copper conductors only.
3. Not suitable on systems that exceed 150V to ground.
4. If any of the original wire as supplied with the furnace must be replaced, it must be replaced with wiring material having a temperature rating of at least 105°C.

5. For supply wire ampacities and overcurrent protection, see unit rating plate.
6. Ensure that wires from the blower remain connected to the board thermostat terminals after making the field thermostat connections.
7. A heat pump thermostat with fossil fuel back-up heat capability is REQUIRED for this system.

1. Couper le courant avant de faire le travail.
2. Employez uniquement des conducteurs en cuivre.
3. Ne convient pas aux installations de plus de 150 V à la terre.

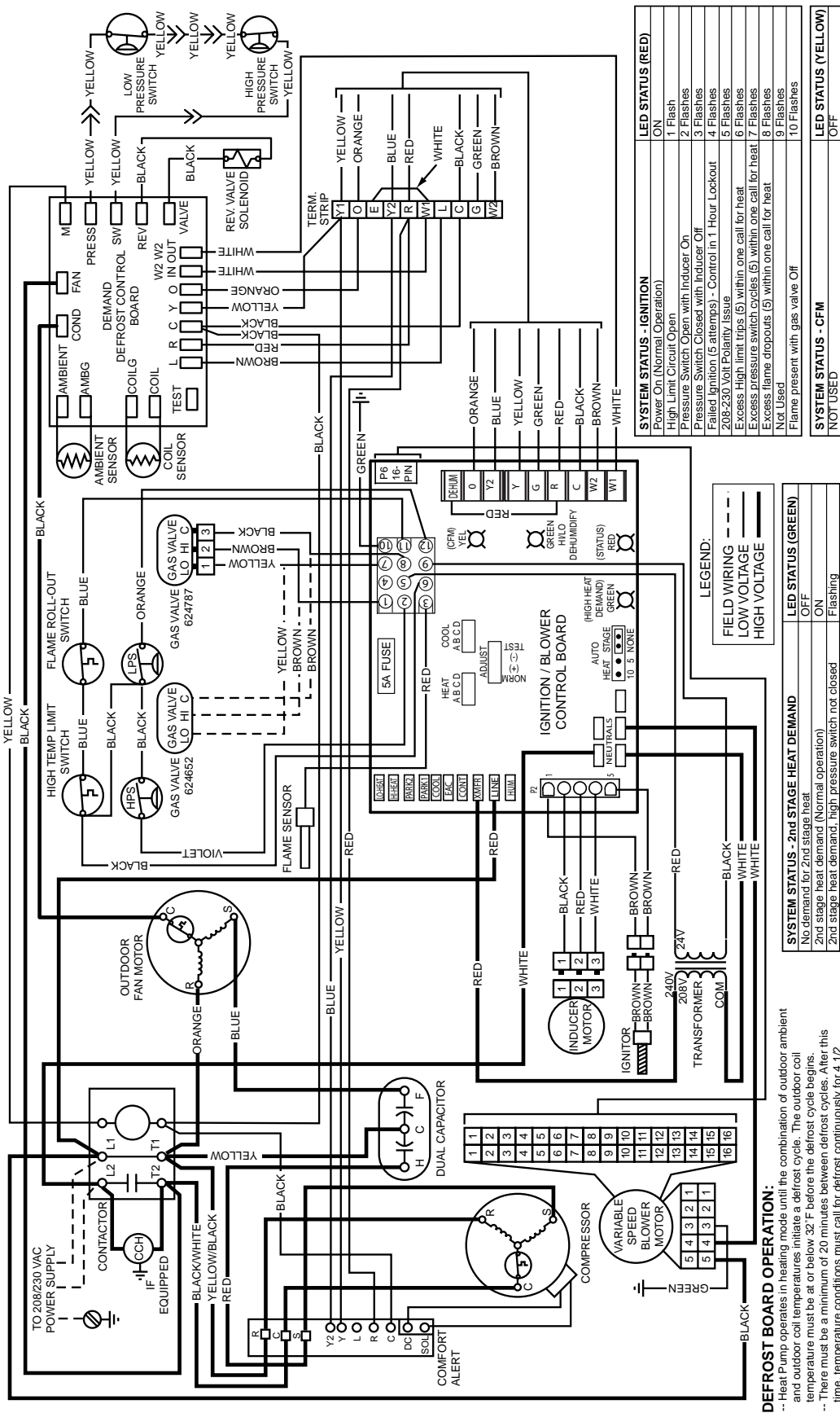

DEFROST BOARD OPERATION:

- Heat Pump operates in heating mode until the combination of outdoor ambient and outdoor coil temperatures initiate a defrost cycle. The outdoor coil temperature must be at or below 32°F before the defrost cycle begins.
- There must be a minimum of 20 minutes between defrost cycles. After this time, temperature conditions must call for defrost continuously for 4 1/2 minutes before a defrost cycle is initiated.
- The defrost cycle ends when either the outdoor coil temperature sensor reaches the defrost terminate set point, or 13 minutes, 39 seconds of compressor run time has elapsed with the control in the defrost mode. (See installation instructions for available terminate temperatures and their specific jumper location)

SYSTEM STATUS - 2nd STAGE HEAT DEMAND	LED STATUS (GREEN)
No demand for 2nd stage heat	OFF
2nd stage heat demand (Normal operation)	ON
2nd stage heat demand, high pressure switch not closed	Flashing

SYSTEM STATUS - HI/LO DEHUMIDIFY (Cooling Mode only)	LED STATUS (GREEN)
Factory jumper wire "R" to "DEHUM" in place or "Close on Fail" humidistat (Low humidity) - Closed Humidistat open, (High Humidity) Low Speed Blower call	ON
	OFF

SYSTEM STATUS - IGNITION	LED STATUS (RED)
Power On (Normal Operation)	ON
High Limit Circuit Open	1 Flash
Pressure Switch Open with Inducer On	2 Flashes
Pressure Switch Closed with Inducer Off	3 Flashes
Failed Ignition (5 attempts) - Control in 1 Hour Lockout	4 Flashes
208/230 Volt Polarity Issue	5 Flashes
Excess high limit trips (5) within one call for heat	6 Flashes
Excess pressure switch cycles (5) within one call for heat	7 Flashes
Excess flame dropouts (5) within one call for heat	8 Flashes
Not Used	9 Flashes
Flame present with gas valve Off	10 Flashes

SYSTEM STATUS - CFM	LED STATUS (YELLOW)
NOT USED	OFF



7111850
(Replaces 711138A)

11/11

Figure 15. Two Stage Cool, Two Stage Heat (Heat Pump)
Two-Stage Gas Heating - With Optional Comfort Alert (2 & 5 Ton Only)

WIRING DIAGRAM

Dual Fuel Heating and Cooling Packaged System

208/230 Volt

Single Phase / 60 Hz.

NOTES:

1. Disconnect power before servicing.
2. For supply connections use copper conductors only.
3. Not suitable on systems that exceed 150V to ground.
4. If any of the original wire as supplied with the furnace must be replaced, it must be replaced with wiring material having a temperature rating of at least 105°C.

5. For supply wire ampacities and overcurrent protection, see unit rating plate.
6. Ensure that wires from the blower remain connected to the board thermostat terminals after making the field thermostat connections.
7. A heat pump thermostat with fossil fuel back-up heat capability is REQUIRED for this system.

1. Couper le courant avant de faire l'entretien.
2. Employez uniquement des conducteurs en cuivre.
3. Ne convient pas aux installations de plus de 150 V à la terre.

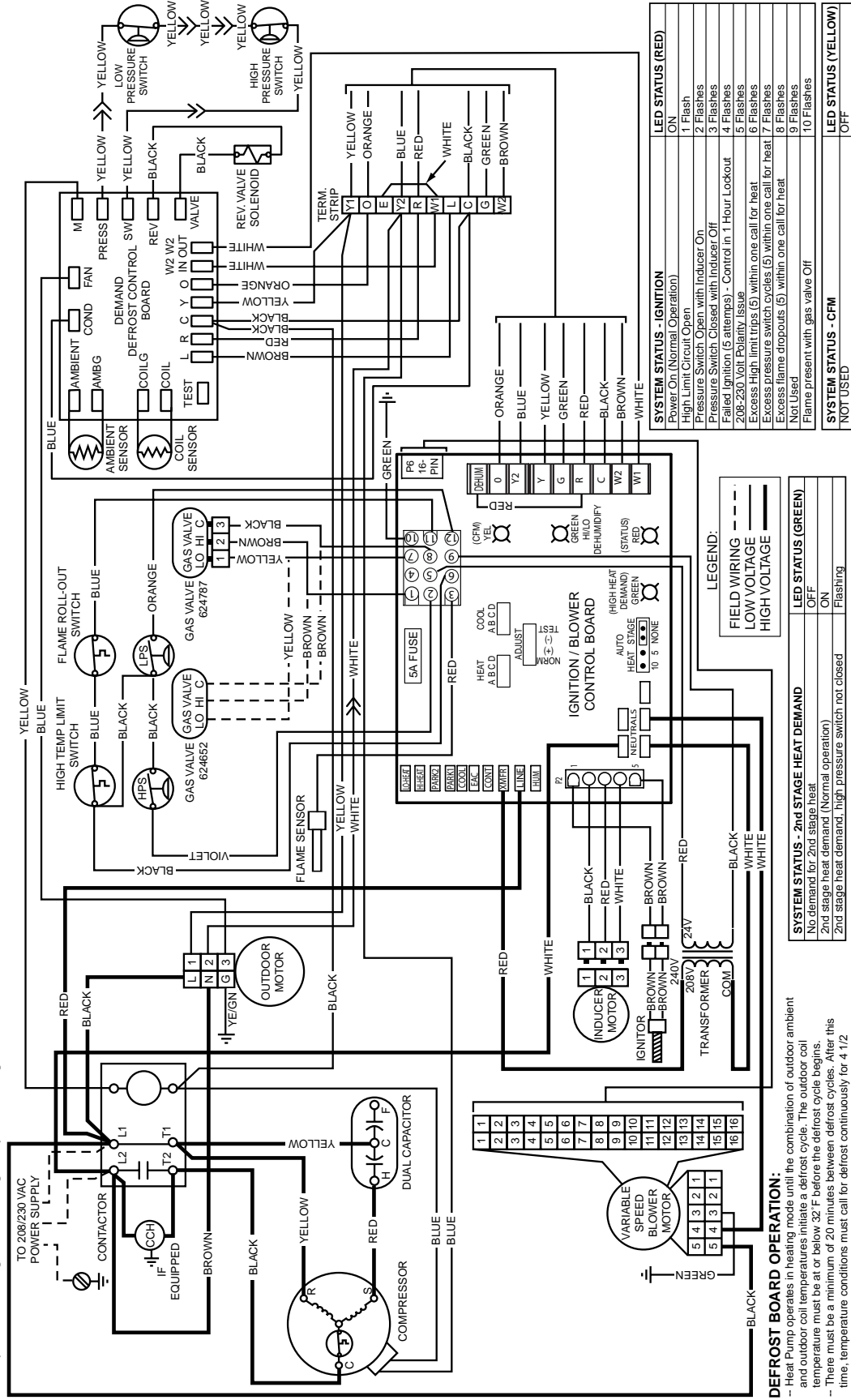

DEFROST BOARD OPERATION:

- Heat Pump operates in heating mode until the combination of outdoor ambient and outdoor coil temperatures initiate a defrost cycle. The outdoor coil temperature must be at or below 32°F before the defrost cycle begins.
- There must be a minimum of 20 minutes between defrost cycles. After this time, temperature conditions must call for defrost continuously for 4 1/2 minutes before a defrost cycle is initiated.
- The defrost cycle ends when either the outdoor coil temperature sensor reaches the defrost terminate set point, or 13 minutes, 39 seconds of compressor run time has elapsed with the control in the defrost mode. (See installation instructions for available terminate temperatures and their specific jumper location).

SYSTEM STATUS - 2nd STAGE HEAT DEMAND	LED STATUS (GREEN)
No demand for 2nd stage heat	OFF
2nd stage heat demand (Normal operation)	ON
2nd stage heat demand, high pressure switch not closed	Flashing

SYSTEM STATUS - HI/LO DEHUMIDIFY (Cooling Mode only)	LED STATUS (GREEN)
Factory jumper wire "R" to "DEHUM" in place or "Close on Fail" humidistat (Low humidity) - Closed	ON
Humidistat open (High Humidity) Low Speed Blower call	OFF

SYSTEM STATUS - IGNITION	LED STATUS (RED)
Power On (Normal Operation)	ON
High Limit Circuit Open	1 Flash
Pressure Switch Open with Inducor On	2 Flashes
Pressure Switch Closed with Inducor Off	3 Flashes
Failed Ignition (5 attempts) - Control in 1 Hour Lockout	4 Flashes
208-230 Volt Polarity Issue	5 Flashes
Excess high limit trips (5) within one call for heat	6 Flashes
Excess pressure switch cycles (5) within one call for heat	7 Flashes
Excess flame dropouts (5) within one call for heat	8 Flashes
Flame present with gas valve Off	9 Flashes
Flame present with gas valve On	10 Flashes

SYSTEM STATUS - CFM	LED STATUS (YELLOW)
NOT USED	OFF

7113340
(Replaces 7111860)

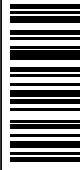

2/13

Figure 16. Two Stage Cool, Two Stage Heat (Heat Pump) Two-Stage Gas Heating (3 & 4 Ton)

WIRING DIAGRAM

Dual Fuel Heating and Cooling Packaged System

208/230 Volt

Single Phase / 60 Hz.

NOTES:

1. Disconnect power before servicing.
2. For supply connections use copper conductors only.
3. Not suitable on systems that exceed 150V to ground.
4. If any of the original wire as supplied with the furnace must be replaced, it must be replaced with wiring material having a temperature rating of at least 105°C.

5. For supply wire ampacities and overcurrent protection, see unit rating plate.
6. Ensure that wires from the blower remain connected to the board thermostat terminals after making the field thermostat connections.
7. A heat pump thermostat with fossil fuel back-up heat capability is REQUIRED for this system.

1. Couper le courant avant de faire l'entretien.
2. Employez uniquement des conducteurs en cuivre.
3. Ne convient pas aux installations de plus de 150 V à la terre.

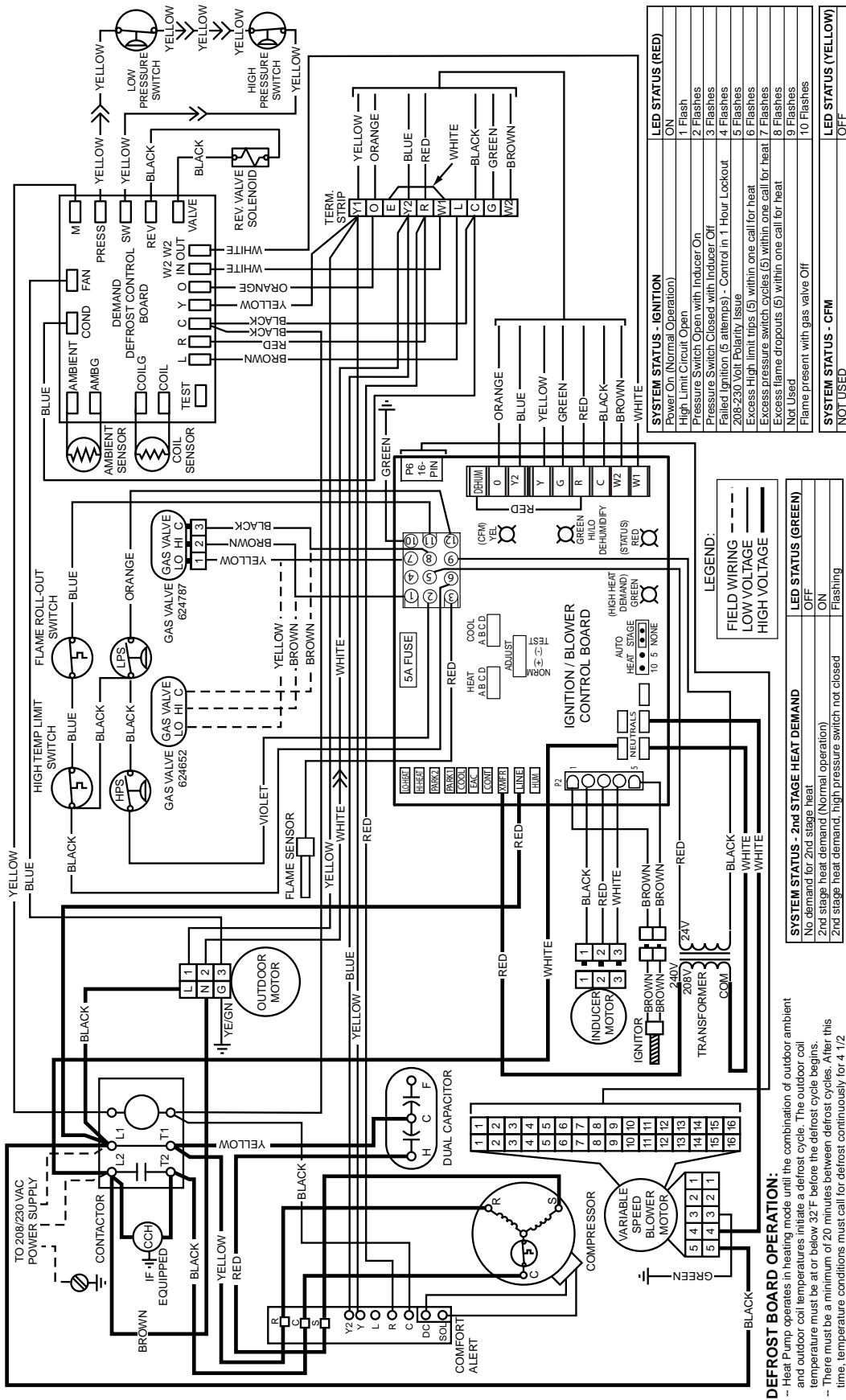

Figure 17. Two Stage Cool, Two Stage Heat (Heat Pump)
Two-Stage Gas Heating "With Optional Comfort Alert" (3 & 4 Ton)

SYSTEM STATUS - 2nd STAGE HEAT DEMAND	LED STATUS (GREEN)
No demand for 2nd stage heat	OFF
2nd stage heat demand (Normal operation)	ON
2nd stage heat demand, high pressure switch not closed	Flashing

SYSTEM STATUS - HILO DEHUMIDIFY (Cooling Mode only)	LED STATUS (GREEN)
Factory jumper wire "R" to "DEHUM" in place or "Close on Fail" humidistat (Low humidity) - Closed	ON
Humidistat open (High Humidity) Low Speed Blower call	OFF

SYSTEM STATUS - IGNITION	LED STATUS (RED)
Power On (Normal Operation)	ON
High Limit Circuit Open	1 Flash
Pressure Switch Open with Inducer On	2 Flashes
Pressure Switch Closed with Inducer Off	3 Flashes
Failed Ignition (5 attempts) - Control in 1 Hour Lockout	4 Flashes
208-230 Volt Polarity Issue	5 Flashes
Excess High limit trips (5) within one call for heat	6 Flashes
Excess pressure switch cycles (5) within one call for heat	7 Flashes
Excess flame dropouts (5) within one call for heat	8 Flashes
Not Used	9 Flashes
Flame present with gas valve Off	10 Flashes

SYSTEM STATUS - CFM	LED STATUS (YELLOW)
NOT USED	OFF

SYSTEM STATUS - IGNITION	LED STATUS (RED)
Power On (Normal Operation)	ON
High Limit Circuit Open	1 Flash
Pressure Switch Open with Inducer On	2 Flashes
Pressure Switch Closed with Inducer Off	3 Flashes
Failed Ignition (5 attempts) - Control in 1 Hour Lockout	4 Flashes
208-230 Volt Polarity Issue	5 Flashes
Excess High limit trips (5) within one call for heat	6 Flashes
Excess pressure switch cycles (5) within one call for heat	7 Flashes
Excess flame dropouts (5) within one call for heat	8 Flashes
Not Used	9 Flashes
Flame present with gas valve Off	10 Flashes

SYSTEM STATUS - CFM	LED STATUS (YELLOW)
NOT USED	OFF

7113350
(Replaces 7111870)
2/13

COMFORT ALERT TROUBLESHOOTING CHARTS

Status LED	Status LED Description	Status LED Troubleshooting Information
POWER (Green LED)	Module has power	Supply voltage is present at module terminals
TRIP (Red LED)	Thermostat demand signal Y is present, but compressor is not running	<ul style="list-style-type: none"> • Compressor protector is open • Check for high head pressure • Check compressor supply voltage • Outdoor unit power disconnect is open • Compressor circuit breaker or fuse(s) is open • Broken wire or connector is not making contact • Low pressure switch open if present in system • Compressor contactor has failed open
ALERT Flash Code 1 (Yellow LED)	Long Run Time Compressor is running extremely long run cycles	<ul style="list-style-type: none"> • Low refrigerant charge • Evaporator blower is not running <ul style="list-style-type: none"> — Check blower relay coil and contacts — Check blower motor capacitor — Check blower motor for failure or blockage — Check evaporator blower wiring and connectors — Check indoor blower control board — Check thermostat wiring for open circuit • Evaporator coil is frozen <ul style="list-style-type: none"> — Check for low suction pressure — Check for excessively low thermostat setting — Check evaporator airflow (coil blockages or return air filter) — Check ductwork or registers for blockage • Faulty metering device <ul style="list-style-type: none"> — Check TXV bulb installation (size, location and contact) — Check if TXV/fixed orifice is stuck closed or defective • Condenser coil is dirty • Liquid line restriction (filter drier blocked if present in system) • Thermostat is malfunctioning <ul style="list-style-type: none"> — Solenoid plug not connected — Y2 not wired at Comfort Alert — Check thermostat sub-base or wiring for short circuit — Check thermostat installation (location, level) • Comfort Alert failure
ALERT Flash Code 2 (Yellow LED)	System Pressure Trip	<ul style="list-style-type: none"> • High head pressure <ul style="list-style-type: none"> — Check high pressure switch if present in system — Check if system is overcharged with refrigerant — Check for non-condensable in system
	Discharge or suction	<ul style="list-style-type: none"> • Condenser coil poor air circulation (dirty, blocked, damaged)
	Pressure out of limits	<ul style="list-style-type: none"> • Condenser fan is not running <ul style="list-style-type: none"> — Check fan capacitor — Check fan wiring and connectors — Check fan motor for failure or blockage
	Compressor overloaded	<ul style="list-style-type: none"> • Return air duct has substantial leakage • If low pressure switch present in system, check Flash Code 1 information

Table 15. LED Diagnostics

Status LED	Status LED Description	Status LED Troubleshooting Information
ALERT Flash Code 3 (Yellow LED)	Short Cycling / Compressor is running only briefly	<ul style="list-style-type: none"> • Thermostat demand signal is intermittent • Low line voltage (contact utility if voltage at disconnect is low) • Excessive liquid refrigerant in compressor • Compressor bearings are seized
ALERT Flash Code 4 (Yellow LED)	Locked Rotor	<ul style="list-style-type: none"> • Run capacitor has failed • Low line voltage (contact utility if voltage at disconnect is low) • Check wiring connections • Excessive liquid refrigerant in compressor • Compressor bearings are seized • Measure compressor oil level
ALERT Flash Code 5 (Yellow LED)	Open Circuit	<ul style="list-style-type: none"> • Outdoor unit power disconnect is open • Compressor circuit breaker or fuse(s) is open • Compressor contactor has failed open <ul style="list-style-type: none"> — Check compressor contactor wiring and connectors — Check for compressor contactor failure (burned, pitted or open) — Check wiring and connectors between supply and compressor — Check for low pilot voltage at compressor contactor coil — High pressure switch is open and requires manual reset • Open circuit in compressor supply wiring or connections • Unusually long compressor protector reset time due to extreme ambient temperature • Compressor windings are damaged <ul style="list-style-type: none"> — Check compressor motor winding resistance
ALERT Flash Code 6 (Yellow LED)	Open Start Circuit Current only in run circuit	<ul style="list-style-type: none"> • Run capacitor has failed • Open circuit in compressor start wiring or connections <ul style="list-style-type: none"> — Check wiring and connectors between supply and the compressor S terminal • Compressor start winding is damaged <ul style="list-style-type: none"> — Check compressor motor winding resistance
ALERT Flash Code 7 (Yellow LED)	Open run circuit Current only in start circuit	<ul style="list-style-type: none"> • Open circuit in compressor run wiring or connections <ul style="list-style-type: none"> — Check wiring and connectors between supply and the compressor R terminal • Compressor run winding is damaged <ul style="list-style-type: none"> — Check compressor motor winding resistance
ALERT Flash Code 8 (Yellow LED)	Welded Contactor Compressor always runs	<ul style="list-style-type: none"> • Compressor contactor has failed closed • Thermostat demand signal not connected to module
ALERT Flash Code 9 (Yellow LED)	Low Voltage Control circuit < 17VAC	<ul style="list-style-type: none"> • Control circuit transformer is overloaded • Low line voltage (contact utility if voltage at disconnect is low) • Check wiring connections

* Flash code number corresponds to a number of LED flashes, followed by a pause and then repeated. Trip and alert LED's flashing at same time means control circuit voltage is too low for operation.

Table 15. LED Diagnostics - Continued

Miswired Module Indication	Recommended Troubleshooting Action
Green LED is not on, module does not power up	<ul style="list-style-type: none"> Determine if both R & C module terminals are connected. Verify voltage is present at module's R & C terminals.
Green LED intermittent, module powers up only when compressor runs	<ul style="list-style-type: none"> Determine if R & Y terminals are wired in reverse. Verify modules R and C terminals have a constant source.
Trip LED is on, but system and compressor check OK	<ul style="list-style-type: none"> Verify Y terminal is connected to 24VAC at contactor coil. Verify voltage at contactor coil falls below 0.5VAC when off. Verify 24VAC is present across Y & C when thermostat demand signal is present. If not, R & C are reversed wired.
TRIP LED & ALERT LED flashing together	<ul style="list-style-type: none"> Verify R and C terminals are supplied with 19 - 28VAC.
ALERT Flash CODE 3 displayed incorrectly (Compressor short cycling)	<ul style="list-style-type: none"> Verify Y terminal is connected to 24VAC at contactor coil. Verify voltage at contactor coil falls below 0.5VAC when off.
ALERT Flash Code 5, 6, or 7 displayed incorrectly (Open Circuit, Open Start Circuit or Open Run Circuit)	<ul style="list-style-type: none"> Verify the compressor run and start wires are routed through the module's current sensing holes. Verify the Y terminal is connected to 24VAC at contactor coil. Verify voltage at contactor coil falls below 0.5VAC when off.
ALERT Flash Code 6 (Open Start Circuit) displayed for Code 7 (Open Run Circuit) or vice-versa	<ul style="list-style-type: none"> Verify the compressor run and start wires are routed through the correct module sensing holes.
ALERT Flash Code 8 displayed incorrectly (Welded Contactor)	<ul style="list-style-type: none"> Determine if module's Y terminal is connected. Verify Y terminal is connected to 24VAC at contactor coil. Verify 24VAC is present across Y & C when thermostat demand signal is present. If not, R and C are reversed wired. Verify voltage at contactor coil falls below 0.5VAC when off. Review Thermostat Demand Wiring (page 10) for Y & C wiring.

Table 16. Module Wiring Troubleshooting

REFRIGERANT CHARGING CHARTS

Application Notes on the Use of Charging Charts

This equipment's cooling system contains refrigerant under high pressure, always use safe practices when servicing the unit. Always review the factory literature and safety warnings prior to servicing.

These units are shipped from the factory with the proper amount and type of refrigerant. Always inspect the unit rating label to determine the unit's information prior to working on the system. Do not mix different refrigerants or charge the unit with a refrigerant not listed on the unit rating label.

The charging charts (Figures 17 - 20 pages 38 - 39) are valid for a variety of indoor, return air conditions and are most highly influenced by the outdoor ambient temperature, outdoor fan operation and the unit operating voltage. Before referencing the charts below, always make sure that the compressor circuit is energized on high speed and has stable operation. As can be seen in the charging charts, the ideal system sub-cooling can vary over the range of operation. Always reference the charts to determine the ideal amount of sub-cooling for a given liquid pressure. Units charged to other values will not perform at the rated unit efficiency (EER).

To inspect a system's operation, using quality instruments, match the measured liquid temperature to the unit's chart. The measured liquid pressure reading should be within 3% of the value shown for most installations. For two stage systems, the charts are valid for compressor operating on high speed.

DO NOT use the charts for a two stage system operating under a single stage call for cooling.

For systems that are operating with more than a 5% deviation, inspect the unit for leaks. Always use safe and environmentally sound methods for refrigerant handling. When repairing system leakages, always utilize a nitrogen (inert) gas to protect the refrigerant system and pressure check the repair before re-charging. Always replace the filter-driers when performing any repair to the refrigeration system. After completing the repairs, evacuate the system to 350-500 microns and weigh in the refrigerant to the amount specified on the unit rating label.

CHARGING CHARTS - CONTINUED

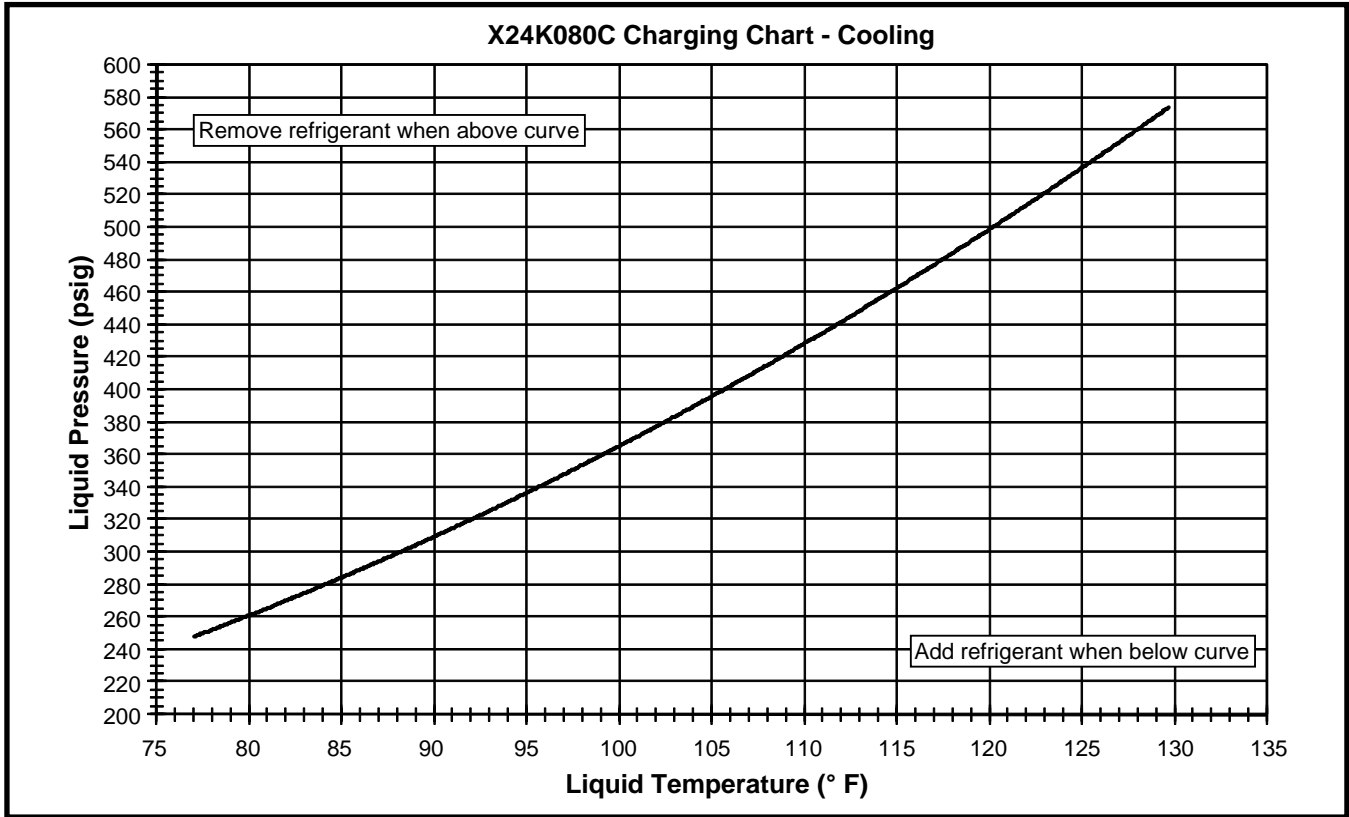

Figure 18. Charging Chart for 2 Ton Units

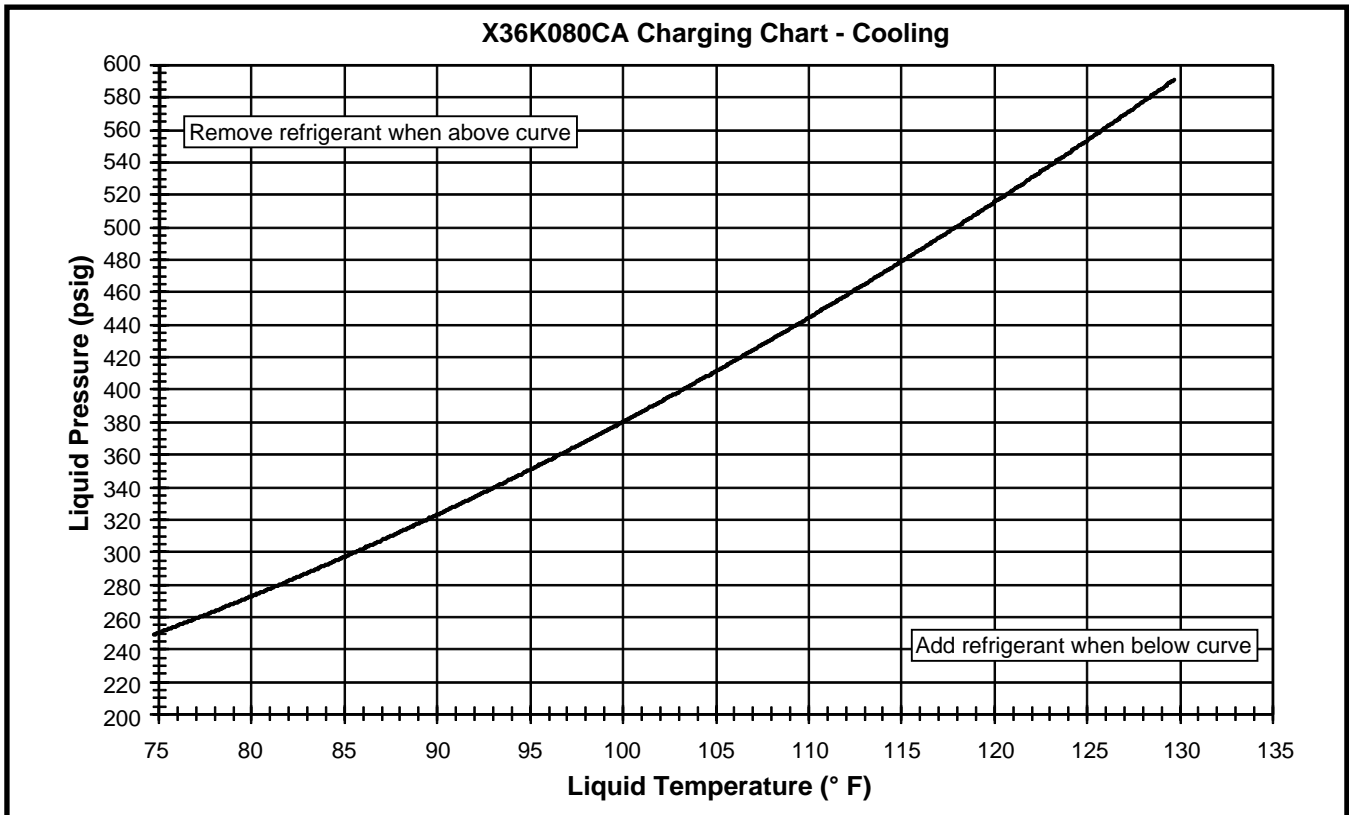

Figure 19. Charging Chart for 3 Ton Units

CHARGING CHARTS - CONTINUED

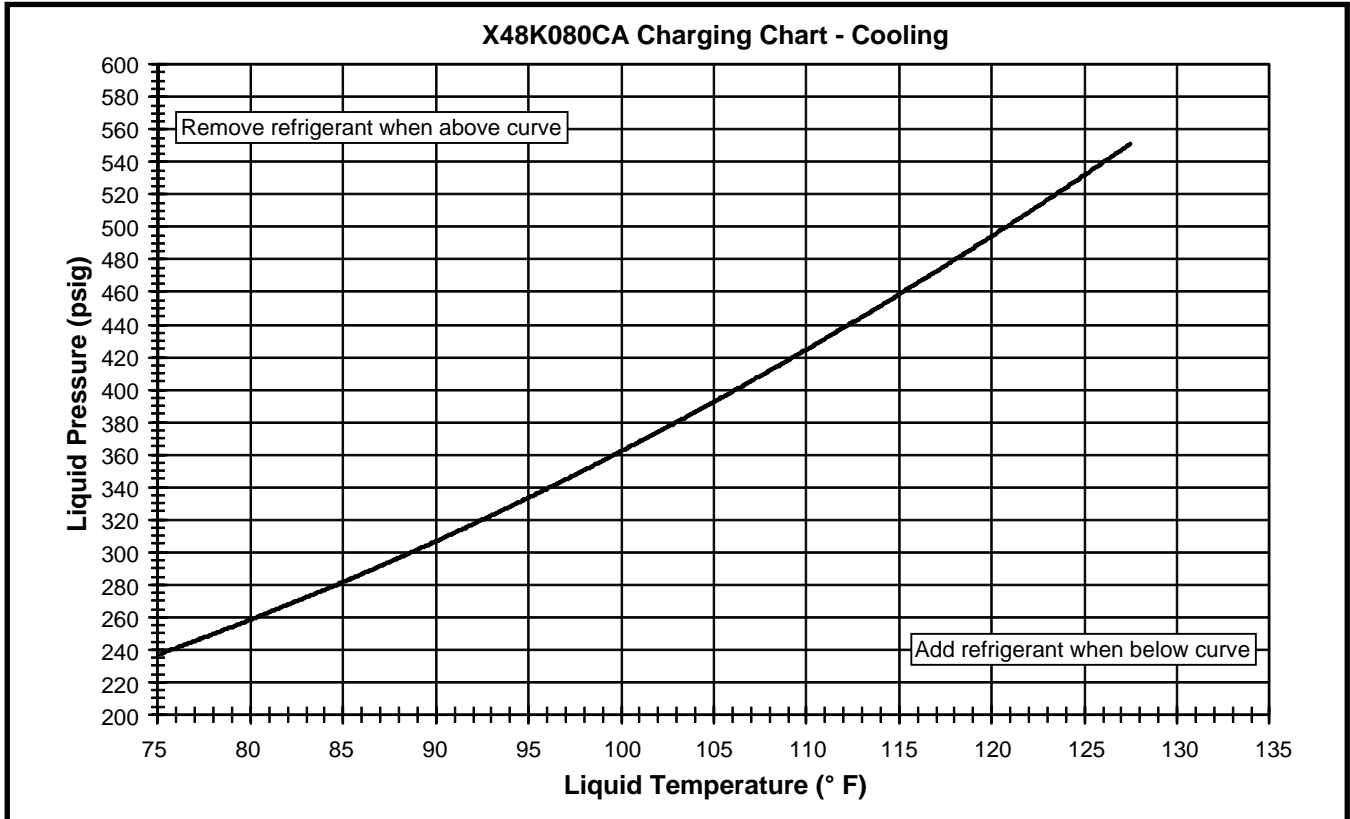

Figure 20. Charging Chart for 4 Ton Units

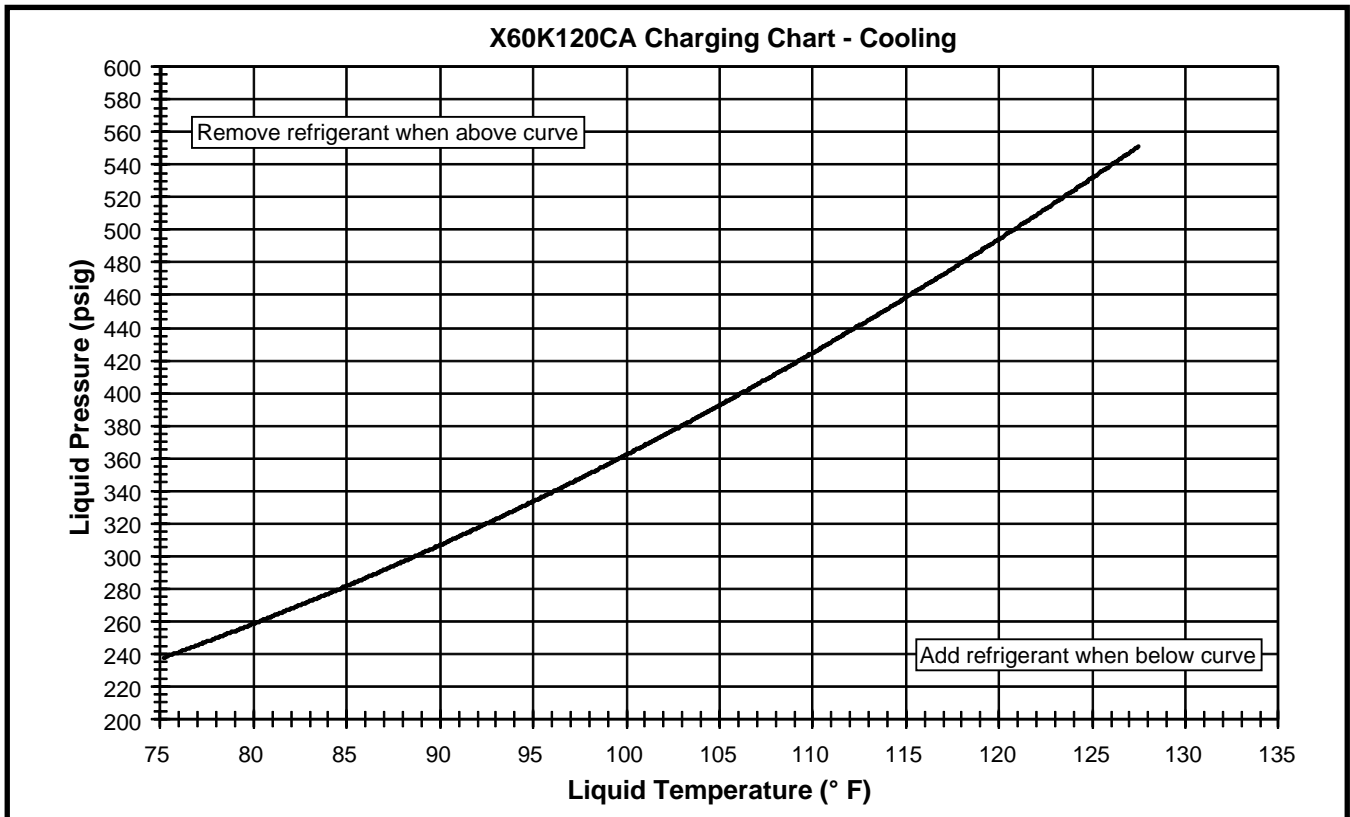

Figure 21. Charging Chart for 5 Ton Units

INSTALLATION / PERFORMANCE CHECK LIST

INSTALLATION ADDRESS:		
CITY _____	STATE _____	
UNIT MODEL # _____		
UNIT SERIAL # _____		
Unit Installed Minimum clearances per Figure 1 (page 5)?	YES	NO
INSTALLER NAME:		
CITY _____	STATE _____	
Has the owner's information been reviewed with the customer?	YES	NO
Has the Literature Package been left with the unit?	YES	NO

ELECTRICAL SYSTEM		
Electrical connections tight?	YES	NO
Line voltage polarity correct?	YES	NO
Rated Voltage: _____ VOLTS		
L1-L2 Volts: _____ VOLTS		
Has the thermostat been calibrated?	YES	NO
Is the thermostat level?	YES	NO
Is the heat anticipator setting correct?	YES	NO

VENTING SYSTEM		
Is the vent hood installed?	YES	NO
Is vent hood free from restrictions	YES	NO
Filter(s) secured in place?	YES	NO
Filter(s) clean?	YES	NO

GAS SYSTEM		
Gas Type: (circle one)	Natural Gas	Propane
Gas pipe connections leak-tested?	YES	NO
Gas Line Pressure: _____ (in - W.C.)		
Is there adequate fresh air supply for combustion and ventilation?	YES	NO
Installation Altitude: _____ (FT.)		
Deration Percentage: _____ (%)		
Furnace Input: _____ (Btuh)		
Supply Air Temperature: _____ (° F)		
Return Air Temperature: _____ (° F)		
Temperature Rise: _____ (° F)		
During Furnace Operation:		
Low fire manifold pressure: _____ (in - W.C.)		
High fire manifold pressure: _____ (in - W.C.)		

REFRIGERATION SYSTEM		
Was unit given 24 hr warm up period for crankcase heaters?	YES	NO
Stage-1 Liquid Pressure (high side) _____		
Stage-1 Suction Pressure (low side) _____		
Stage-2 Liquid Pressure (high side) _____		
Stage-2 Suction Pressure (low side) _____		



IMPORTANT - This product has been designed and manufactured to meet ENERGY STAR criteria for energy efficiency. However, proper refrigerant charge and proper air flow are critical to achieve rated capacity and efficiency. Installation of this product should follow the manufacturer's refrigerant charging and air flow instructions. Failure to confirm proper charge and airflow may reduce energy efficiency and shorten equipment life.



HRAI

YOUR ENVIRONMENT • OUR EXPERTISE
✓ MEMBER COMPANY

NORDYNE

COMPLETE COMFORT. GENUINE VALUE.

Specifications & illustrations subject to change without notice or incurring obligations.
O' Fallon, MO | Printed in U.S.A. (03/13)



7094860 (Replaces 7093430)