

INSTALLATION INSTRUCTIONS

SINGLE PACKAGE AIR CONDITIONER - 2 STAGE, R410A



IMPORTANT

ATTENTION INSTALLERS:

It is your responsibility to know this product better than your customer. This includes being able to install the product according to strict safety guidelines and instructing the customer on how to operate and maintain the equipment for the life of the product. Safety should always be the deciding factor when installing this product and using common sense plays an important role as well. Pay attention to all safety warnings and any other special notes highlighted in the manual. Improper installation of the furnace or failure to follow safety warnings could result in serious injury, death, or property damage.

These instructions are primarily intended to assist qualified individuals experienced in the proper installation of this appliance. Some local codes require licensed installation/service personnel for this type of equipment. Please read all instructions carefully before starting the installation. Return these instructions to the customer's package for future reference.

DO NOT DESTROY. PLEASE READ CAREFULLY & KEEP IN A SAFE PLACE FOR FUTURE REFERENCE.

TABLE OF CONTENTS

Important Safety Information	3	Startup & Adjustments	10
General Information	4	Pre - Start Checklist	10
Before You Install this Unit	4	Start - Up Procedure	10
Locating the Air Conditioner	4	Air Circulation.....	10
Minimum Clearance Requirements	4	System Cooling.....	10
Service Access Clearances	4	System Heating.....	10
Clearances to Combustible Materials	4	Refrigerant Charging	10
Air Duct System	4	Charging an R410A Unit in AC Mode w/ Outdoor	
Air Conditioner Installation	5	Temperatures above 55° F	10
Unpacking the Unit	5	Air Conditioner Maintenance	11
Installing Return & Supply Collars.....	5	Component Functions	11
Supply Duct	5	Replacement Parts	11
Return Duct	5	Figures & Tables	12
Locating & Installing the Return Air Assembly	6	Figure 7 - Unit Dimensions	12
Locating & Installing the Supply Dampers.....	6	Table 4 - Physical Data	12
Condensate Drainage	6	Refrigerant Charging Charts	13
Electrical Connections	6	Figure 8 - Charging Chart for 2 Ton Units	13
Pre - Electrical Checklist	6	Figure 9 - Charging Chart for 3 Ton Units	13
Line Voltage.....	6	Figure 10 - Charging Chart for 4 Ton Units	14
Grounding.....	7	Figure 11 - Charging Chart for 5 Ton Units	14
Overcurrent Protection	7	Wiring Diagrams.....	15
Thermostat / Low Voltage Connections.....	8	Figure 12 - 2 & 3 Ton Units	15
2-Stage Heating	8	Figure 13 - 4 & 5 Ton Units	16
Cooling Mode.....	9	Installation / Performance Checklist	20
Electric Heat Package (optional)	9		
Blower Speed	9		
Outdoor Motor (4 & 5 Ton)	9		

IMPORTANT SAFETY INFORMATION

Please read all instructions before servicing this equipment. Pay attention to all safety warnings and any other special notes highlighted in the manual. Safety markings are used frequently throughout this manual to designate a degree or level of seriousness and should not be ignored. **WARNING** indicates a potentially hazardous situation that if not avoided, could result in personal injury or death. **CAUTION** indicates a potentially hazardous situation that if not avoided, may result in minor or moderate injury or property damage.

WARNING:

ELECTRICAL SHOCK, FIRE OR EXPLOSION HAZARD

Failure to follow safety warnings exactly could result in serious injury or property damage.

Improper servicing could result in dangerous operation, serious injury, death or property damage.

- Before servicing, disconnect all electrical power to the indoor blower.
 - When servicing controls, label all wires prior to disconnecting. Reconnect wires correctly.
 - Verify proper operation after servicing.
-

WARNING:

These units are fully charged with R-410A refrigerant and ready for installation. When a system is installed according to these instructions, no refrigerant charging is required. If repairs make it necessary for evacuation and charging, it should only be attempted by qualified, trained personnel thoroughly familiar with this equipment. Some local codes require licensed installation service personnel to service this type of equipment. Under no circumstances should the equipment owner attempt to install and/or service this equipment. Failure to comply with this warning could result in equipment damage, personal injury, or death.

CAUTION:

This unit uses R-410A refrigerant. **DO NOT use any other refrigerant in this unit. Use of another refrigerant will damage the unit.**

WARNING:

The information listed below must be followed during the installation, service, and operation of this unit. Unqualified individuals should not attempt to interpret these instructions or install this equipment. If you do not possess mechanical skills or tools, call your local dealer for assistance. Failure to follow safety recommendations could result in possible damage to the equipment, serious personal injury or death.

- The installer must comply with all local codes and regulations which govern the installation of this type of equipment. Local codes and regulations take precedence over any recommendations contained in these instructions. Consult local building codes and the National Electrical Code (ANSI C1) for special installation requirements.
- All electrical wiring must be completed in accordance with local, state and national codes and regulations and with the National Electric Code (ANSI/NFPA 70) or in Canada the Canadian Electric Code Part 1 CSA C.22.1.
- This equipment contains liquid and gaseous refrigerant under high pressure. **DO NOT USE ANY PORTION OF THE CHARGE FOR PURGING OR LEAK TESTING.** Installation or servicing should only be performed by qualified trained personnel thoroughly familiar with this type equipment.
- Use caution when handling this appliance or removing components. Personal injury can occur from sharp metal edges present in all sheet metal constructed equipment.
- This unit is designed for outdoor installations only and should be located in a position as shown on page 6.
- Follow all precautions in the literature, on tags, and on labels provided with the equipment. Read and thoroughly understand the instructions provided with the equipment prior to performing the installation and operational checkout of the equipment.
- The installer should become familiar with the units wiring diagram before making any electrical connections to the unit. See the unit wiring label or Figures 12 - 13 (pages 15 - 16).

GENERAL INFORMATION

This air conditioner is designed only for outdoor ground level installations and can be readily connected to the high static duct system of a home. This unit has been tested for capacity and efficiency in accordance with AHRI Standards and will provide many years of safe and dependable comfort, providing it is properly installed and maintained. Abuse, improper use, and/or improper maintenance can shorten the life of the appliance and create unsafe hazards.

Before You Install this Unit

- ✓ The cooling load of the area to be conditioned must be calculated and a system of the proper capacity selected. It is recommended that the area to be conditioned be completely insulated and vapor sealed.
- ✓ Check the electrical supply and verify the power supply is adequate for unit operation. If there is any question concerning the power supply, contact the local power company.
- ✓ All units are securely packed at the time of shipment and upon arrival should be carefully inspected for damage prior to installing the equipment at the job site. Verify coil fins are straight. If necessary, comb fins to remove flattened or bent fins. Claims for damage should be filed immediately with the carrier.
- ✓ Please consult your dealer for maintenance information and availability of maintenance contracts. Please read all instructions before installing the unit.

Locating the Air Conditioner

- Survey the job site to determine the best location for mounting the outdoor unit. Select a solid, level position, preferably on a concrete slab, slightly above the grade level, and parallel to the home. If possible, select a site for the unit that is as close as possible to the proposed return grille location. **DO NOT PLACE UNIT UNDER THE HOME.**
- The unit should be located with consideration of minimizing the length of the supply and return ducts. If practical, place the air conditioner and its ducts in an area where they will be shaded from the afternoon sun, when the heat load is greatest.

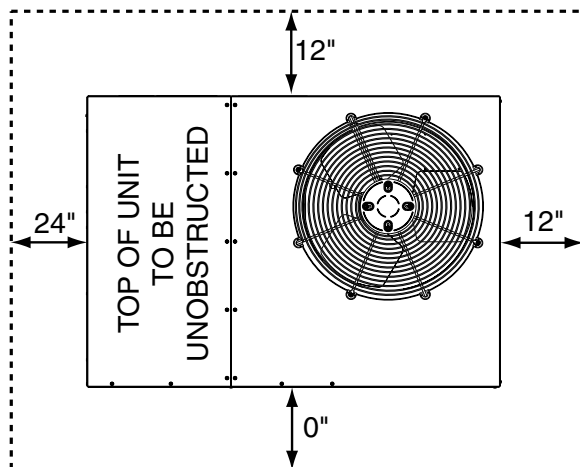

Figure 1. Minimum Unit Clearances

- The length of the supply and return ducts should be kept to a minimum with no sharp radius bends.
- Overhead obstructions, poorly ventilated areas, and areas subject to accumulation of debris should be avoided. The hot condenser air must be discharged up and away from the home, and if possible, in a direction with the prevailing wind. Do not place the unit in a confined space.
- Consideration should also be given to availability of electric power, service access, noise, and shade.

Minimum Clearance Requirements

Sufficient clearance for unobstructed airflow through the outdoor coil must be maintained in order to provide room for proper servicing and achieve rated performance. See Figure 1 for minimum clearances to obstructions.

Service Access Clearance

Blower access panel side	24"
Electrical compartment access panel side	12"
Clearance between overhang and top of unit.....	72"
Clearance around condenser coil area to wall or shrubs (excludes duct panel side).....	12"

Clearances to Combustible Materials

Supply and return air ducts.....	0"
Duct connection side	0"

Air Duct System

Air ducts must be installed in accordance with the standards of the National Fire Protection Association "Standard for Installation of Air Conditioning and Ventilation Systems" (NFPA 90A), "Standard for Installation of Residence Type Warm Air Heating and Air Conditioning Systems" (NFPA 90B), these instructions, and all applicable codes. NFPA publications are available by writing to: National Fire Protection Association, Batterymarch Park, Quincy, ME 02269 or visit www.NFPA.org on the web.

- Design the duct work according to methods described by the Air Conditioning Contractors of America (ACCA).
- The supply duct system, including the number and type of registers, will have much more effect on the performance of the system than any other factor. The duct must be sufficiently large to conduct an adequate amount of air to each register. See Figure 2 (page 5).
- Duct work should be attached directly to the unit flanges for horizontal applications.
- For highly resistive duct systems it may be necessary to add an additional return air duct and or supply to achieve maximum performance and prevent coil icing and refrigerant flood back.
- **The air conditioning output of the system will not cool the home if air is lost to the outside through leaks in the duct system. Ducts that are collapsed or restricted by foreign objects will also prevent adequate air flow.**
- All duct work passing through unconditioned space must be properly insulated to minimize duct losses and prevent condensation. Use insulation with an outer vapor barrier. Refer to local codes for insulation material requirements.

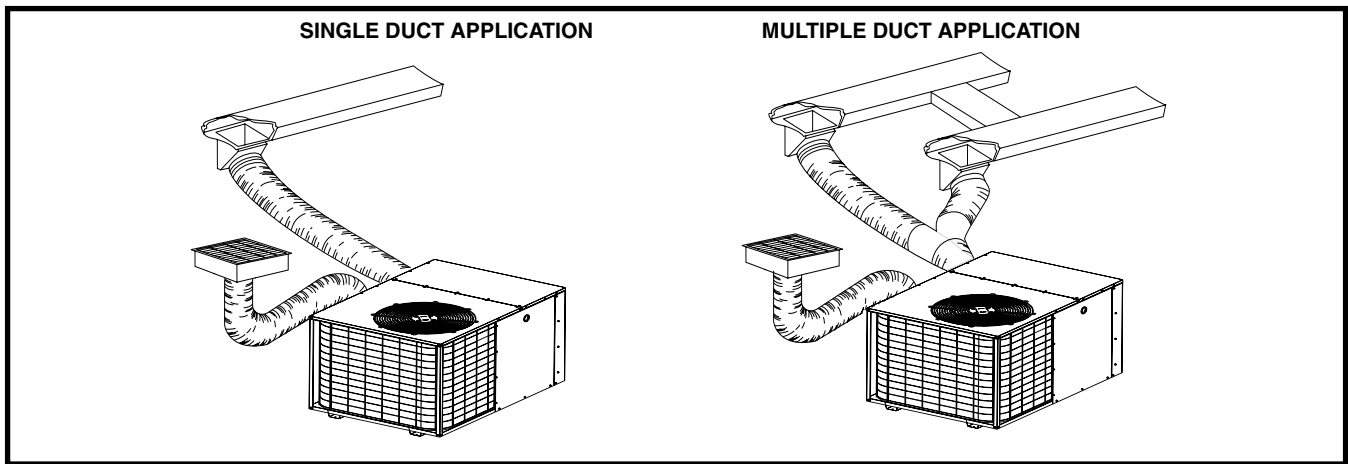

Figure 2. Single & Multiple Duct Applications

AIR CONDITIONER INSTALLATION

Unpacking the Unit

It is recommended that the unit be unpacked at the installation site to minimize damage due to handling.

CAUTION:

Do not tip the unit on its side. Oil may enter the compressor cylinders and cause starting trouble. If unit has been set on its side, restore to upright position and do not run for several hours. Then run unit for a few seconds. Do this three or four times with five minutes between runs.

1. Remove the bands from around the unit.
2. Unfold the top and bottom cap flanges.
3. Carefully remove the top cap and tube.

Installing Return & Supply Air Collars

If the supply and return collars are supplied with the unit, they will be located in the supply duct. They can be easily positioned over the unit openings (Figure 3) and secured with sheet metal screws.

- The diameter of the return duct collar is 14".
- The diameter of the supply duct collar is 12".
- Before permanently installing the collars, it is recommended you pre-fit them over the openings first to determine best fit and alignment.

Supply Duct

1. Position the supply duct collar so the edge of the unit opening fits between the flange and the bead.
2. Overlap the collar ends keeping the small screw holes underneath.
3. Align the holes in the crimped area and install one screw. **NOTE:** It may be necessary to loosen the four screws that hold the transition duct in order to install the supply fitting. Re-tighten when installation is complete.
4. Tap collar (if necessary) to ensure engagement with unit opening and install second screw.
5. Tighten first screw and rotate collar clockwise so joint is near three o'clock position.

Return Duct

1. Assemble the collar by overlapping the two ends. **NOTE:** One end of the collar is slotted and the opposite end has two small holes. Position the end with small screw holes underneath the slotted end.
2. Fasten the collar ends with two self drilling sheet metal screws.
3. Position the collar over the unit opening. Align the four holes in the collar with the four dimples or holes (depending on unit model) in the panel.
4. Secure the collar to the rear panel using self drilling screws (10-16x.5).

Locating & Installing the Return Air Assembly

To simplify installation, locate and install the return air assembly first. If desired, the return opening can be located inside a closet with louvered doors that has an open area equal to or greater than a 12" x 20" grille. The return air grille can be placed in the wall of a closet and the air ducted into the filter box through a boxed-in area at the closet floor level. Verify the filter is readily accessible.

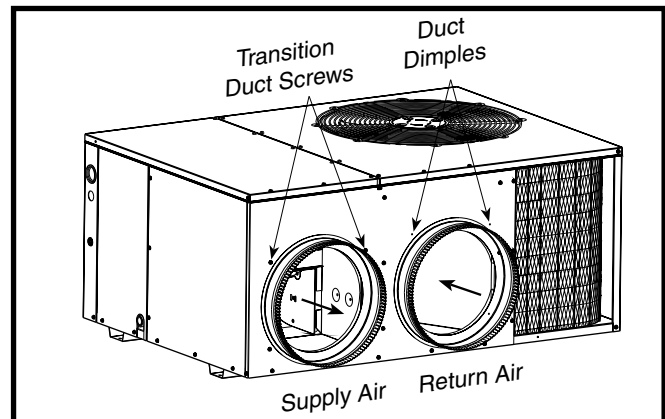

Figure 3. Return & Supply Air Collars

CAUTION:

If installing this air conditioning system in conjunction with a furnace, a damper must be installed in the furnace base assembly to prevent cold air from being discharged around the heat exchanger. Damage to the heat exchanger and asphyxiation may occur if a damper is not installed.

Check with the furnace manufacturer for damper requirements. Failure to install the required furnace damper may invalidate code agency listing and limited warranty on the furnace.

Condensate Drainage

A 3/4" condensate fitting extends out of the side of the unit as shown in Figure 4. The drain trap (shipped in the electrical compartment), must be installed to prevent water from collecting inside the unit.

1. Thread the elbow provided with the unit into the drain connection until hand tight.
2. Connect the condensate tubing onto the fitting, forming a trap near the drain connection.
3. Route the condensate tube from the trap to a suitable drain. **NOTE:** For proper drainage, make sure the trap is level to the ground and tubing outlet is below trap level.

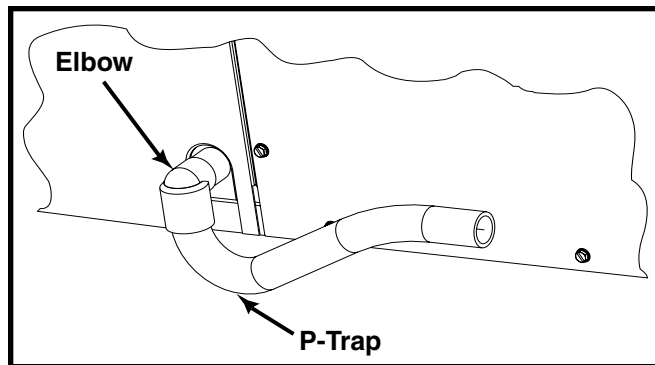

Figure 4. Drain Trap

WARNING:

To avoid risk of electrical shock, personal injury, or death, disconnect all electrical power to the unit before performing any maintenance or service. The unit may have more than one electrical supply.

Label all wires prior to disconnection when servicing the unit. Wiring errors can cause improper and dangerous operation

- All electrical connections must be in compliance with all applicable local codes and ordinances, and with the current revision of the National Electric Code (ANSI/NFPA 70).
- For Canadian installations the electrical connections and grounding shall comply with the current Canadian Electrical Code (CSA C22.1 and/or local codes).

Pre-Electrical Checklist

- ✓ Verify that the voltage, frequency, and phase of the supply source match the specifications on the unit rating plate.
- ✓ Verify that the service provided by the utility is sufficient to handle the additional load imposed by this equipment. Refer to the unit wiring label for proper high and low voltage wiring.
- ✓ Verify factory wiring is in accordance with the unit wiring diagram (Figures 12 & 13, pages 15 & 16). Inspect for loose connections.

Line Voltage

- A wiring diagram is located on the inside cover of the electrical box of the unit. The installer should become familiar with the wiring diagram before making any electrical connections to the unit.
- **An electrical disconnect must be located within sight of and readily accessible to the unit.** This switch shall be capable of electrically de-energizing the unit.
- Line voltage to the unit should be supplied from a dedicated branch circuit containing the correct fuse or circuit breaker for the unit. Incoming field wiring and minimum size of electrical conductors and circuit protection must be in compliance with information listed on the unit data label. Any other wiring methods must be acceptable to authority having jurisdiction.
- Provide power supply for the unit in accordance with the unit wiring diagram, and the unit rating plate. Connect the line-voltage leads to the terminals on the contactor inside the control compartment. Extend leads through power wiring hole (Figure 5, page 7). Connect **L1 & L2** directly to the contactor.
- The unit requires both power and control circuit electrical connections. Refer to the wiring diagram / schematic for identification and location of unit field wiring interfaces (Figures 12 & 13). Make all electrical connections in accordance with all applicable codes and ordinances.

- Overcurrent protection must be provided at the branch circuit distribution panel and sized as shown on the unit rating label and according to applicable local codes. See the unit rating plate for minimum circuit ampacity and maximum overcurrent protection limits.
- Use only copper wire for the line voltage power supply to this unit as listed in Table 1. Use proper code agency listed conduit and a conduit connector for connecting the supply wires to the unit. Use of rain tight conduit is recommended.
- 208/230 Volt units are shipped from the factory wired for 230 volt operation. For 208V operation, remove the lead from the transformer terminal marked 240V and connect it to the terminal marked 208V.
- Optional equipment requiring connection to the power or control circuits must be wired in strict accordance of the NEC (ANSI/NFPA 70), applicable local codes, and the instructions provided with the equipment.

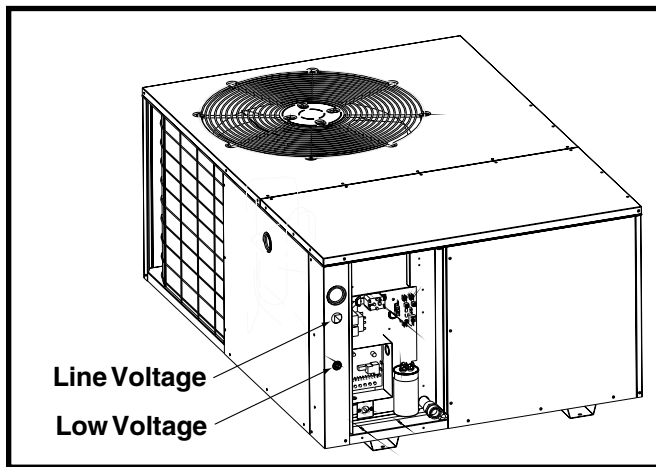

Figure 5. Power Entry

Grounding

WARNING:

The unit cabinet must have an uninterrupted or unbroken electrical ground to minimize personal injury if an electrical fault should occur. Do not use gas piping as an electrical ground!

This unit must be electrically grounded in accordance with local codes or, in the absence of local codes, with the National Electrical Code (ANSI/NFPA 70) or CSA C22.1 Electrical Code. Ground the air conditioning unit using the green grounding screw provided in the control panel.

Overcurrent Protection

Generally, the best fuse or breaker for any air conditioner is the smallest size that will permit the equipment to run under normal usage and provide maximum equipment protection. Properly sized fuses and breakers also prevent nuisance trips during unit startup. **If a fuse blows or a breaker trips, always determine the reason. Do not arbitrarily install a larger fuse or breaker and do not, in any case, exceed the maximum size listed on the data label of the unit.**

COPPER WIRE SIZE — AWG (1% Voltage Drop)				
Supply Wire Length-Feet				Supply Circuit Ampacity
200	150	100	50	
6	8	10	14	15
4	6	8	12	20
4	6	8	10	25
4	4	6	10	30
3	4	6	8	35
3	4	6	8	40
2	3	4	6	45
2	3	4	6	50
2	3	4	6	55
1	2	3	4	60

Wire Size based on N.E.C. for 60° type copper conductors.

Table 1. Copper Wire Size

Thermostat / Low Voltage Connections

- These units are designed to operate with a 24 VAC Class II control circuit. The control circuit wiring must comply with the current provisions of the NEC (ANSI/NFPA 70) and with applicable local codes having jurisdiction. Thermostat connections should be made in accordance with the instructions supplied with the thermostat and the indoor equipment.
- The low voltage wires must be properly connected. Route 24V control wires through the sealing grommet (Figure 4, page 6) near the power entrance. Connect the control wires to the defrost board and blower relay wire (Figure 6). Recommended wire gauge and wire lengths for typical thermostat connections are listed in Table 2.
- Single stage or two-stage heating thermostats can be used with this equipment depending on optional accessories installed with the unit. Select a thermostat that operates in conjunction with the installed accessories.
- The thermostat should be mounted about 5 feet above the floor on an inside wall. **DO NOT** install the thermostat on an outside wall or any other location where its operation may be adversely affected by radiant heat from fireplaces, sunlight, or lighting fixtures, and convective heat from warm air registers or electrical appliances. Refer to the thermostat manufacturer's instruction sheet for detailed mounting information. **NOTE:** If installing unit with an external furnace, refer to the installation instructions supplied with the furnace for proper heat anticipator setting.
- The 15 SEER air conditioner uses a special two speed compressor to achieve a high level of efficiency in a compact frame. For the highest efficiency, the use of a

2-stage Heat / Cool thermostat should be used with this unit. The heat / cool thermostat prevents simultaneous operation of the heating and cooling units and is equipped with an ON-AUTO fan mode that allows the home owner to operate the indoor blower when only air circulation is desired.

Thermostat Wire Gauge	Recommended T-Stat Wire Length (Unit to T-Stat)	
	2-Wire (Heating)	5-Wire (Heating/Cooling)
24	55	25
22	90	45
20	140	70
18	225	110

Table 2. Thermostat Wire Gauge

Heat / Cool Thermostat

A 2 stage Cooling thermostat is recommended for this product. A single or two stage heating thermostat may be used depending on the optional accessories installed with the unit. Install a thermostat that operates in conjunction with the installed accessories. See Figure 6 for 5 or 6 wire Heat / Cool applications

2 Stage Heat with Single Stage Heating Thermostat - If a single stage heat thermostat is used and 2 stage heat is desired, an "optional" outdoor thermostat may be installed. Connect the "optional" outdoor thermostat between the W1 (brown) connection and orange wire in the outdoor unit. See Figure 6. Refer to the installation Instructions supplied with the outdoor thermostat for setup details.

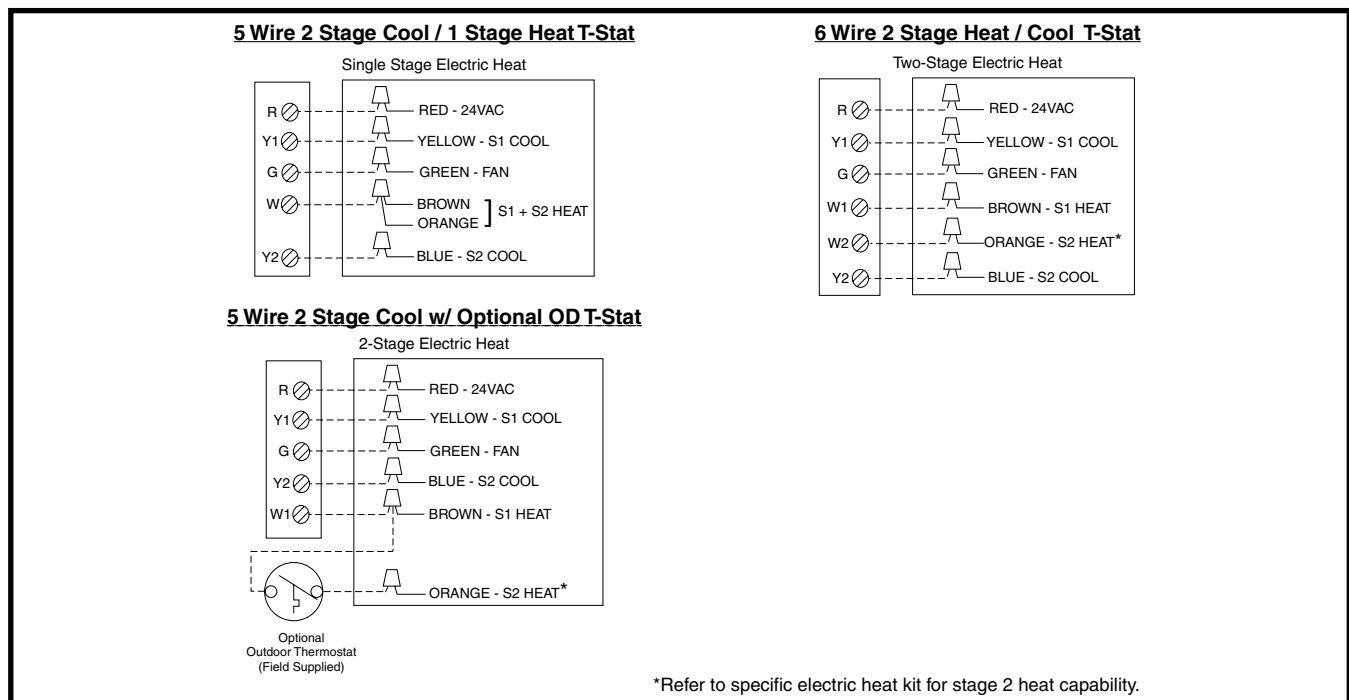

*Refer to specific electric heat kit for stage 2 heat capability.

Figure 6. Typical Wiring (Field Supplied) for 2-Stage Cool & 1 or 2-Stage Electric Heat

Cooling Mode

1. On a call for cooling, the thermostat closes, and applies 24VAC to the **G** & **Y1** terminals of the control. The compressor contactor closes and operates the compressor in 1st stage.
2. If the thermostat is not satisfied in the required time (based on the operation of the 2-stage cooling thermostat), **Y2** will energize and the compressor will run at 2nd stage. Refer to the thermostat's Installation Instructions for the cooling profile.
3. When the thermostat is satisfied, the **G** & **Y** terminals on the control board de-energized and open the compressor contactor.

Electric Heat Package (optional)

This air conditioner is shipped without an auxiliary electric heat kit installed. If electric heat is desired, an accessory heater kit must be field installed.

- Select the correct size heat package for the installation. See specifications sheet for available kits and application. Install the heater kit according to the to the installation instructions provided with the kit.
- Installation is most easily accomplished before making duct or electrical connections.
- The blower must be set to high speed for electric heat operation. Refer to Table 3 for airflow data.

MODEL NUMBER P5RF -	WIRE COLOR / SPEED TAP	External Static Pressure Drop (inches water column)							
		0.1	0.2	0.3	0.4	0.5	0.6	0.7	0.8
X24KA	Tap T1*	625	591	526	445	—	—	—	—
	Tap T2	772	735	693	632	562	491	—	—
	Tap T3**	899	870	844	797	736	670	597	540
	Tap T4***	1085	1044	1015	984	948	887	841	777
	Tap T5	1227	1179	1146	1114	1086	1058	1011	951
X36KA	Tap T1*	905	833	785	630	589	560	515	—
	Tap T2	1136	1093	1052	1012	967	922	867	825
	Tap T3**	1170	1133	1085	1050	1014	970	933	890
	Tap T4***	1485	1450	1405	1378	1340	1300	1264	1230
	Tap T5	1608	1570	1535	1505	1470	1425	1375	1320
X48KA	Tap T1*	1116	1001	950	915	869	783	755	708
	Tap T2	1148	1118	1074	1034	987	943	884	840
	Tap T3***	1491	1447	1413	1358	1324	1290	1247	1208
	Tap T4**	1539	1504	1462	1425	1385	1350	1309	1273
	Tap T5	1777	1747	1716	1672	1639	1599	1569	1531
X60KA	Tap T1*	1172	1120	1077	1045	985	933	895	860
	Tap T2	1187	1160	1119	1084	1043	987	935	897
	Tap T3***	1692	1655	1604	1587	1452	1506	1465	1420
	Tap T4	1785	1744	1705	1667	1635	1584	1546	1505
	Tap T5**	1875	1833	1800	1762	1734	1698	1658	1625

* Denotes Factory Set Low Cooling Speed

** Denotes Factory Set High Cooling Speed

*** Denotes Factory Set Electric Heating Speed

Table 3. Airflow Data

Blower Speed

For optimum system performance and comfort, it may be necessary to change the factory speed setting. See Table 3 for factory settings. **NOTE:** This model has a high efficiency ECM motor with 5 speed taps.

WARNING:

To avoid electric shock, personal injury, or death, turn off the electric power at the disconnect or the main service panel before making any electrical connections.

To Change the blower speed of the high efficiency motor:

1. Disconnect all electrical power to the unit and remove the service panel.

CAUTION:

Label all wires prior to disconnection when servicing controls. Wiring errors can cause improper and dangerous operation. Verify proper operation after servicing.

2. Locate the orange, black and blue wires terminated to the blower motor. The black wire controls the low speed cooling and heating operations, the blue wire controls high speed cooling and heating operations, and the orange wire controls the electric heating operation.

CAUTION:

To avoid personal injury or property damage, make certain that the motor leads cannot come into contact with any metal components of the unit.

3. Verify the required speed from the airflow data found in Table 3. Place appropriate wire on the appropriate motor speed tap for the required airflow.
4. Check all factory wiring per the unit wiring diagram and inspect the factory wiring connections to be sure none loosened during shipping or installation.

Outdoor Motor - 4 & 5 Ton Models Only

The outdoor motor has variable speeds which adjust in conjunction with the compressor and indoor blower motor. The outdoor motor is preset at the factory and wired as shown:

- 4 Ton Model: White wire is connected to **Y1** and the yellow wire is connected to **Y2**.
- 5 Ton Model: Yellow wire is connected to **Y1** and the white wire is connected to **Y2**.

NOTE: The blue wire from the outdoor ECM motor is always common for either speed setting.

START UP & ADJUSTMENTS

Pre-Start Checklist

The following check list should be observed prior to starting the unit.

- √ Verify the unit is level and allows proper condensate drainage.
- √ Verify the outdoor coil and top of the unit are free from obstructions and debris, and all equipment access/control panels are in place. Unit must be installed with the proper clearances as listed in Figure 1 (page 4).
- √ Verify that the duct work is sealed to prevent air leakage.
- √ Verify that the line voltage power leads are securely connected and the unit is properly grounded. Check the condenser fan to make sure it turns freely.
- √ Verify the thermostat is wired correctly and installed in a proper location. Make sure the low voltage wires are securely connected to the correct leads on the low voltage terminal strip.
- √ Verify that the power supply branch circuit overcurrent protection is sized properly.

Start-Up Procedure

NOTE: The control circuit thermostat may consist of an anti-short cycle timer that will not let the compressor re-start before 3 - 5 minutes have elapsed.

1. Set the system mode to OFF and the temperature mode to its highest setting.
2. Turn power on at the disconnect switch.
3. Set the system mode to ON or COOL.
4. Set the temperature mode below room temperature. Verify that the indoor blower, outdoor fan, and compressor energize and the cooling function starts.
5. Verify the discharge air grilles are adjusted and the system air is balanced.
6. Verify the duct work has no air leaks.
7. Verify the condensate drain is installed correctly and functions properly.
8. Set the temperature mode above room temperature. The unit should stop.
9. Instruct the homeowner on unit and thermostat operation and filter servicing.

Air Circulation

Leave the thermostat system mode on OFF, and set the fan mode to ON. Blower should run continuously. Check the air delivery at the supply registers and adjust register openings for balanced air distribution. If air is insufficient, examine the ductwork for leaks or obstructions. Set the thermostat fan mode to AUTO. The blower should stop running.

System Cooling

Change the thermostat's system mode to COOL and the fan mode to AUTO. Set the thermostat temperature selector below the existing room temperature. Allow the cooling system to operate for several minutes and check for the discharge of cool air at the supply registers.

System Heating

(Available only when Electric heat is supplied)

1. Set the thermostat's system mode to HEAT and the fan mode to either AUTO (intermittent air) or to ON (continuous air).
2. Set the thermostat's temperature selector above existing room temperature:
3. Allow the system to operate for several minutes and check the supply registers for warm air.
4. Verify the outdoor AC compressor and fan are not running. **NOTE:** The indoor blower will run according to the thermostat's fan mode setting.

REFRIGERANT CHARGING

CAUTION:

Packaged AC units contain liquid and gaseous refrigerant under pressure. Adjustment of refrigerant charge should only be attempted by qualified, trained personnel thoroughly familiar with the equipment and safe responsible refrigerant handling procedures. Under no circumstances should the homeowner attempt to install and/or service this equipment. Failure to comply with this warning could result in equipment damage, personal injury, or death.

- To achieve rated capacity and efficiency the compressor must be exposed to refrigerant for at least 24 hours prior to running. After unit startup, the compressor must run for a minimum of 12 hours.
- The refrigerant charge can be checked and adjusted through the service ports provided external to the unit. Use only gage line sets which have a "Schradler" depression device present to actuate the valve.

Charging an R-410A Unit in AC Mode

(with Outdoor Temperatures Above 55° F)

1. With the system operating in a steady-state, measure the liquid refrigerant pressure (in psig) at the service valve.
 2. Measure the liquid refrigerant temperature (° F) at the service valve.
 3. For the temperature measured, determine the required liquid refrigerant pressure from your units label or charging charts (Figures 8 - 11, pages 13 - 14).
- If the pressure measured in step 1 is greater than the required liquid refrigerant pressure determined in step 3, there is too much charge in the system. Remove refrigerant and repeat steps 1 - 3 until the system is correctly charged.
 - If the pressure measured in step 1 is less than the required liquid refrigerant pressure determined in step 3, there is too little charge in the system. Add refrigerant and repeat steps 1 - 3 until the system is correctly charged.

AIR CONDITIONER MAINTENANCE

WARNING:

To prevent electrical shock, personal injury, or death, disconnect all electrical power to the unit before performing any maintenance or service. The unit may have more than one electrical supply.

Proper maintenance is important to achieve optimum performance from the air conditioner. The ability to properly perform maintenance on this equipment requires certain mechanical skills and tools. If you do not possess these skills, contact your dealer for maintenance. Consult your local dealer about the availability of maintenance contracts.

Routine maintenance should include the following:

- Inspect and clean or replace air filters at the beginning of each heating and cooling season, or more frequently if required.
- Inspect the condensate drain and outdoor coil at the beginning of each cooling season. Remove any debris. Clean the outdoor coil and louvers as necessary using a mild detergent and water. Rinse thoroughly with water.
- Inspect the electrical connections for tightness at the beginning of each heating and cooling season. Service as necessary.

CAUTION:

The unit should never be operated without a filter in the return air system. Replace disposable filters with the same type and size.

- Do not attempt to add additional oil to motors unequipped with oil tubes. The compressor is hermetically sealed at the factory and does not require lubrication.

COMPONENT FUNCTIONS

High Pressure Switch (HPS)

A high-pressure switch is factory-installed and located in the liquid line internal to the unit. The switch is designed to protect the system when very high pressures occur during abnormal conditions. Under normal conditions, the switch is closed. If the liquid pressure rises above 575 psig, the switch will open and de-energize the unit. The switch will close again when the liquid pressure decreases to 460 psig.

Low Pressure Switch (LPS)

A low-pressure switch is factory-installed and located in the suction line internal to the unit. The switch is designed to protect the compressor from a loss of charge. Under normal conditions, the switch is closed. If the suction pressure falls below 5 psig, the switch will open and de-energize the unit. The switch will close again when the suction pressure increases above 20 psig.

REPLACEMENT PARTS

Replacement parts are available through your distributor. Please have the complete model and serial number of the unit when ordering replacement parts.

Electrical

- Capacitors
- Compressors
- Contactors
- Pressure Switches
- Relays
- Temperature Limit Switches
- Thermostats
- Time Delay Relays
- Transformers

Motors

- Blower Motor
- Fan Motor

Components

- Blower Assembly
- Cabinet Panels
- Expansion Valves
- Fan Grille
- Filter/Driers

FIGURES & TABLES

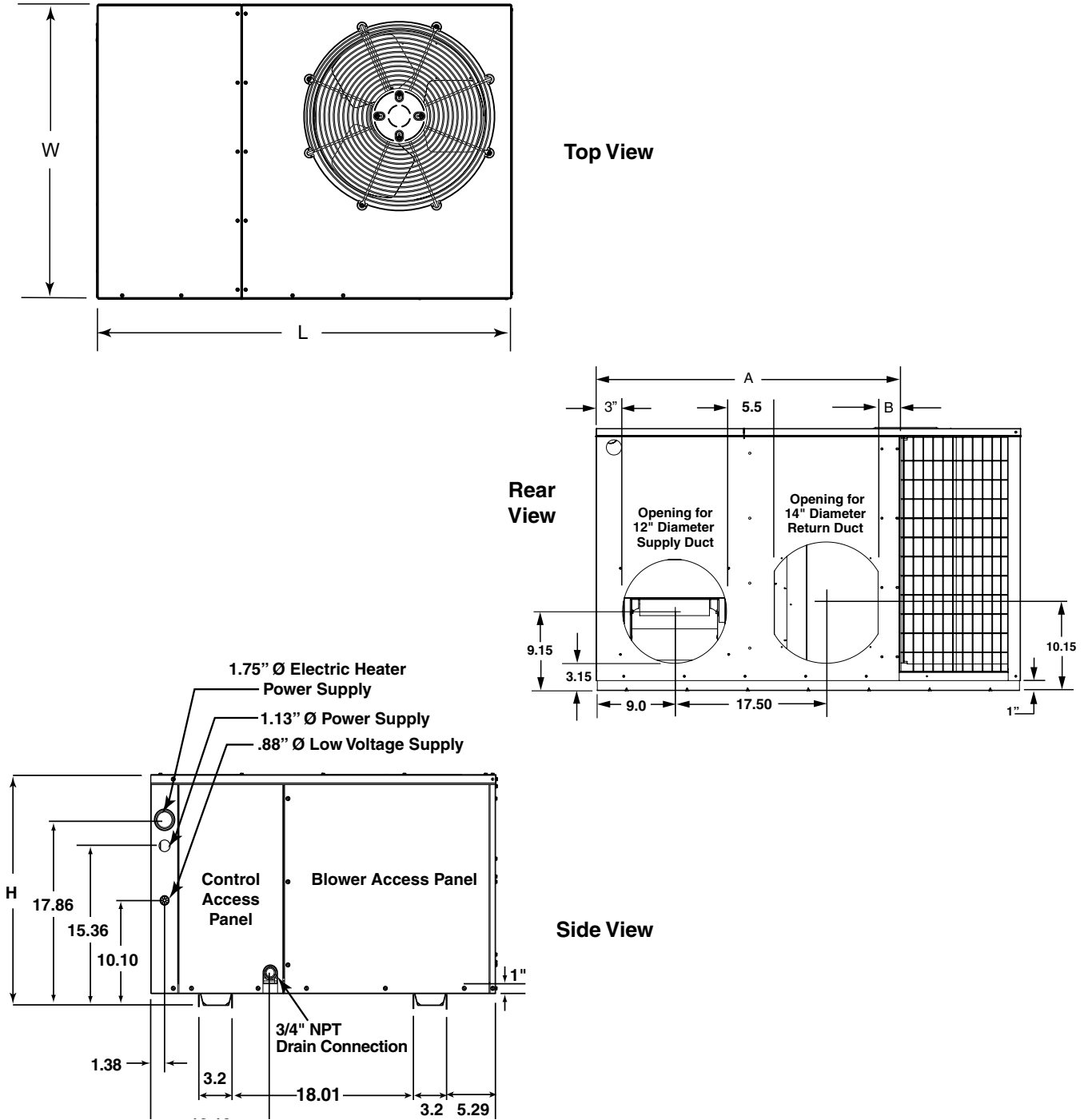

Figure 7. Unit Dimensions

Model Number	(L) Length	(W) Width	(H) Height	A	B
X24KA	49	35	30.2	35.02	2.48
X36KA	49	35	30.2	35.02	2.48
X48KA	49	35	38.2	35.02	2.48
X60KA	63	35	38.2	35.02	2.48

Table 4. Physical Data

REFRIGERANT CHARGING CHARTS

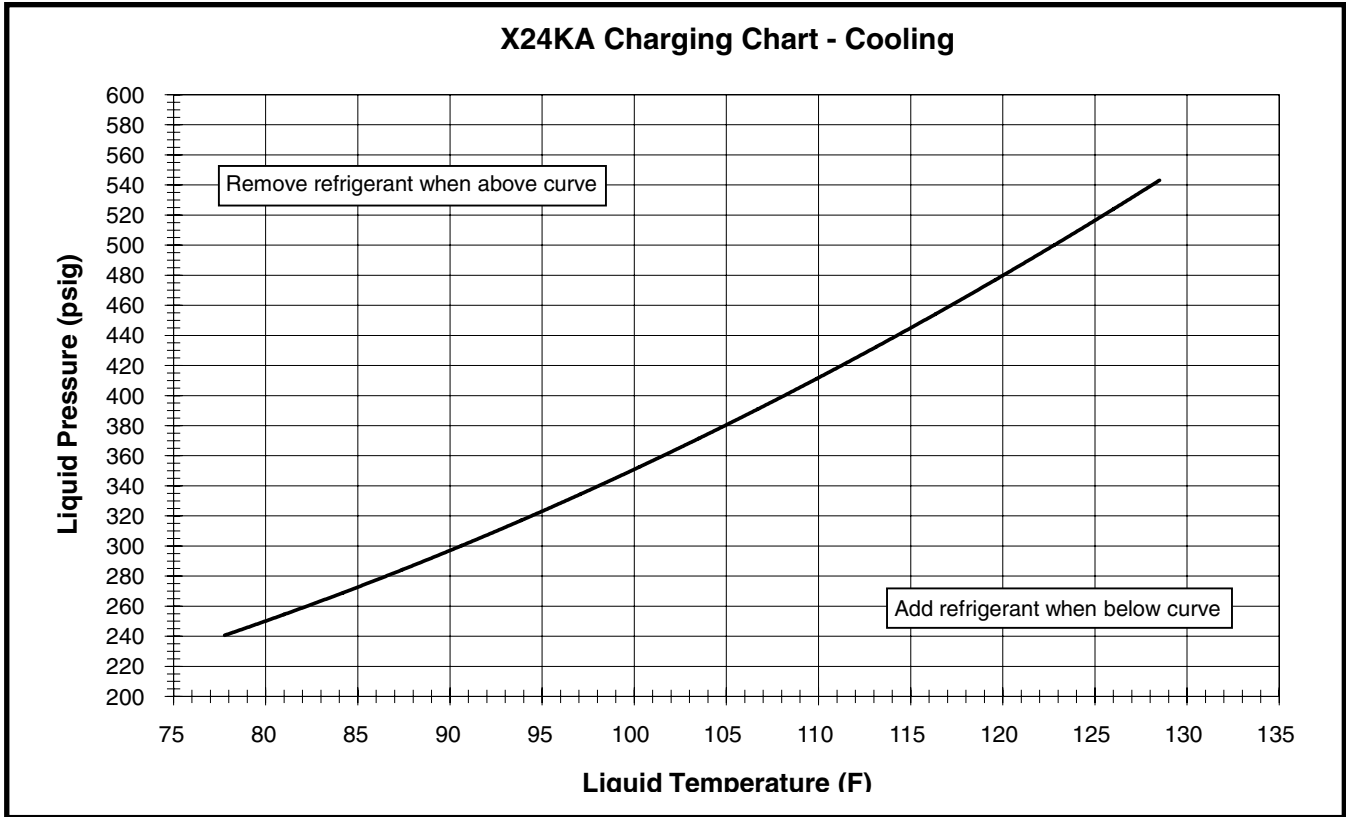

Figure 8. Charging Chart for 2 ton Units

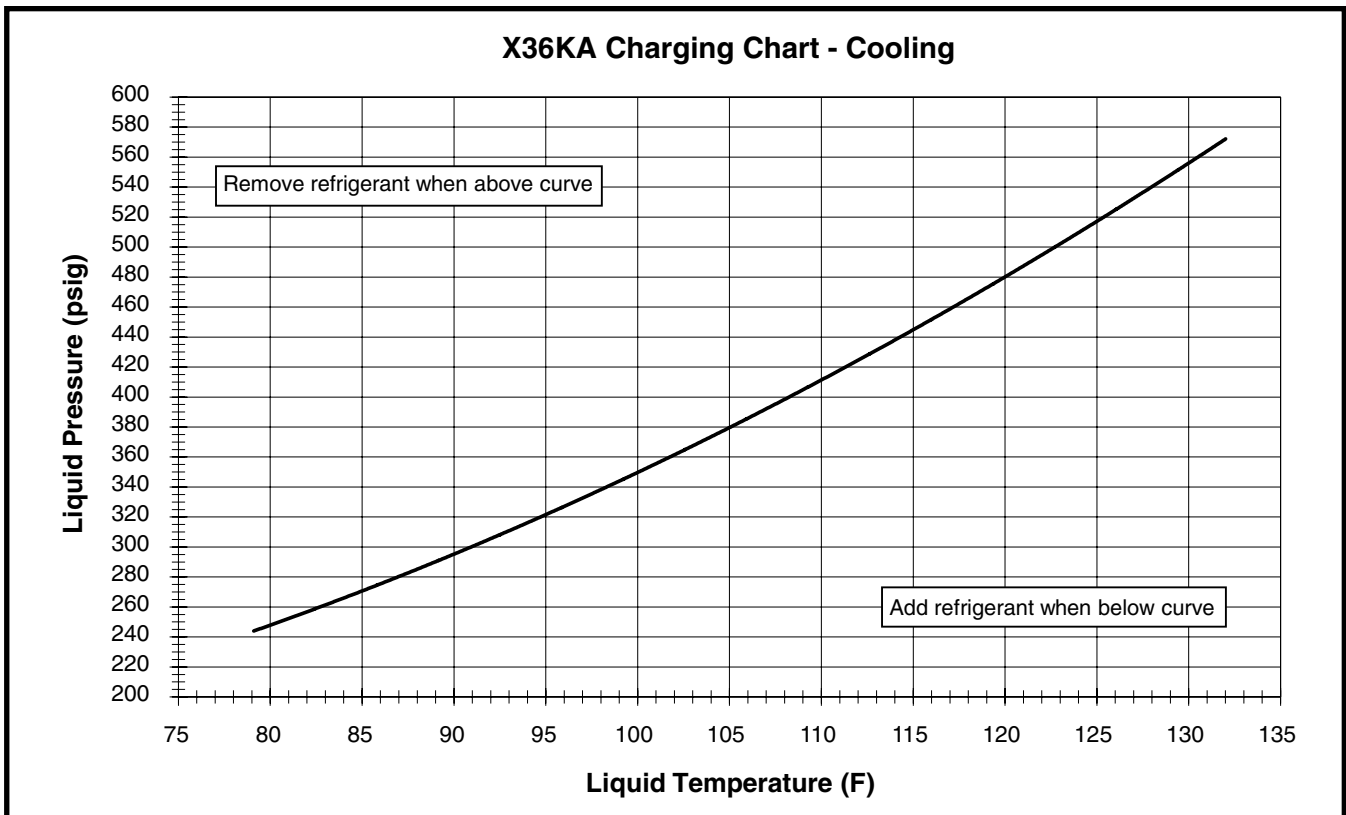

Figure 9. Charging Chart for 3 ton Units

REFRIGERANT CHARGING CHARTS - CONTINUED

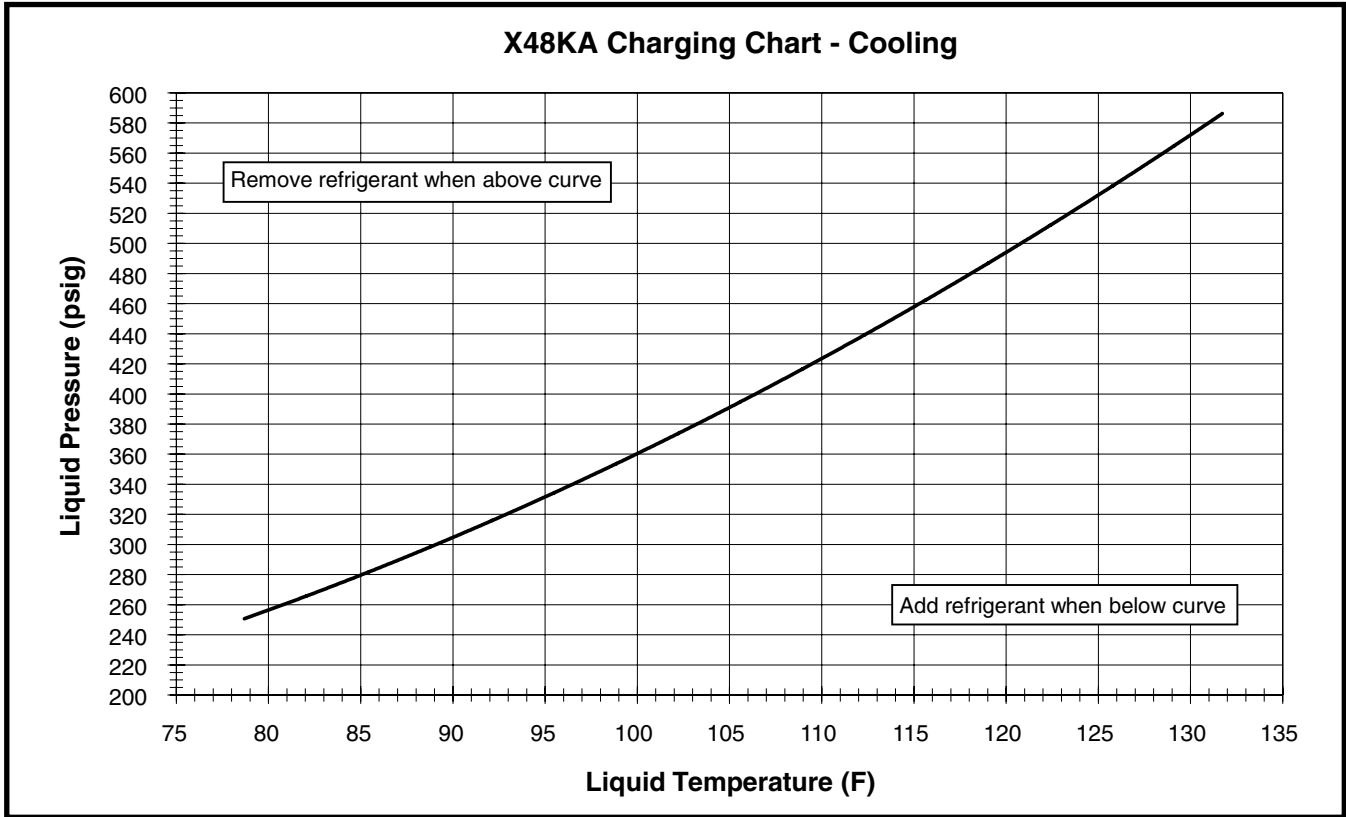

Figure 10. Charging Chart for 4 ton Units

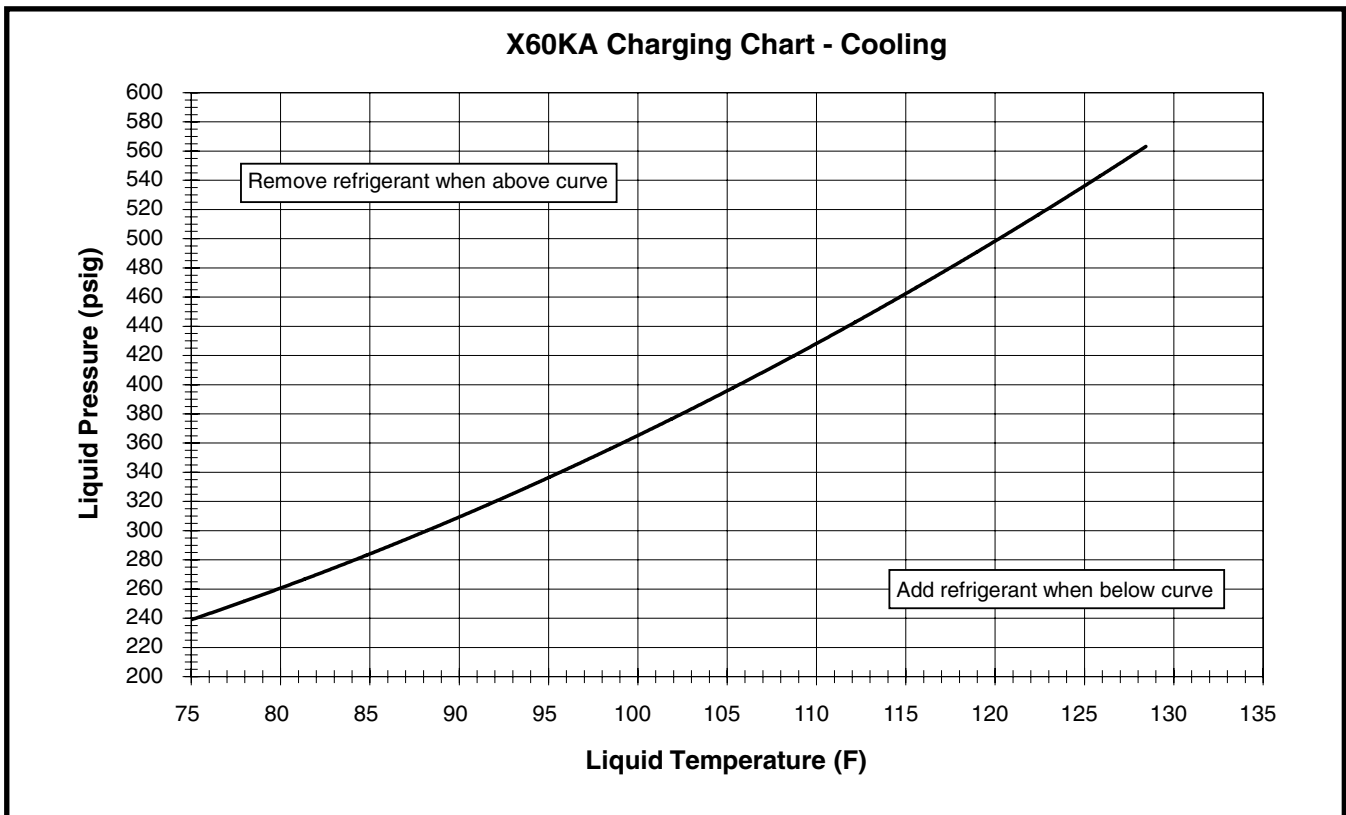

Figure 11. Charging Chart for 5 ton Units

WIRING DIAGRAMS

WIRING DIAGRAM

Packaged Air Conditioner - Single Phase

NOTES:

1. Disconnect all power before servicing.
2. For supply connections use copper conductors only.
3. Not suitable on systems that exceed 150 V to ground.
4. For replacement wires use conductors suitable for 105° C.
5. See installation instructions for blower motor airflow settings

1. Couper le courant avant de faire l'entretien.
2. Employez uniquement des conducteurs en cuivre.
3. Ne convient pas aux installations de plus de 150 V à la terre.

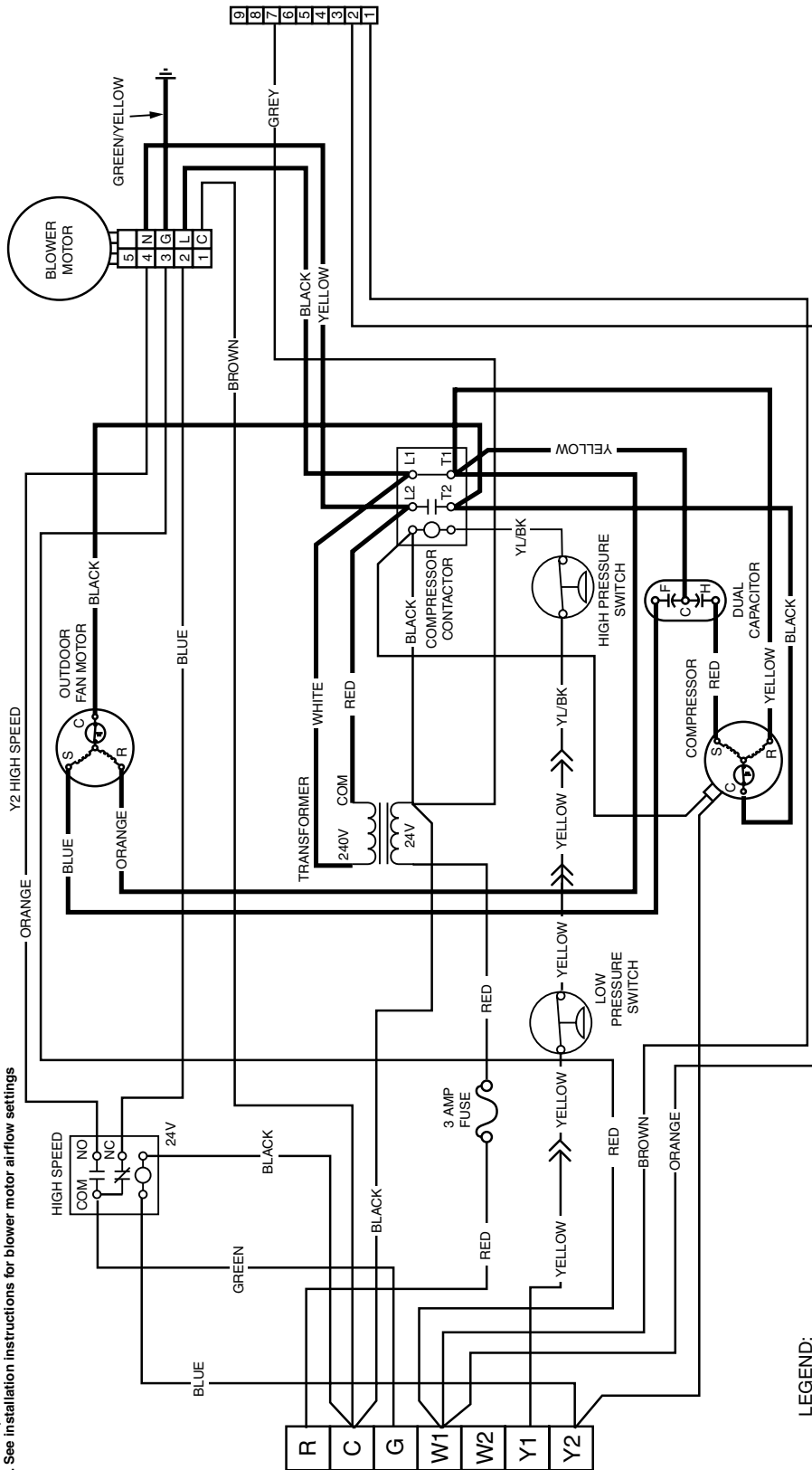

7112720



0812

Figure 12. Wiring Diagram for 2 & 3 Ton Units

WIRING DIAGRAM

Packaged Air Conditioner - Single Phase

NOTES:

1. Disconnect all power before servicing.
2. For supply connections use copper conductors only.
3. Not suitable on systems that exceed 150 V to ground.
4. For replacement wires use conductors suitable for 105° C.
5. See installation instructions for blower motor airflow settings.
6. Outdoor fan wiring shown for four ton unit. For five ton outdoor fan wiring, connect WHITE wire to Y2 and connect YELLOW wire to Y1.

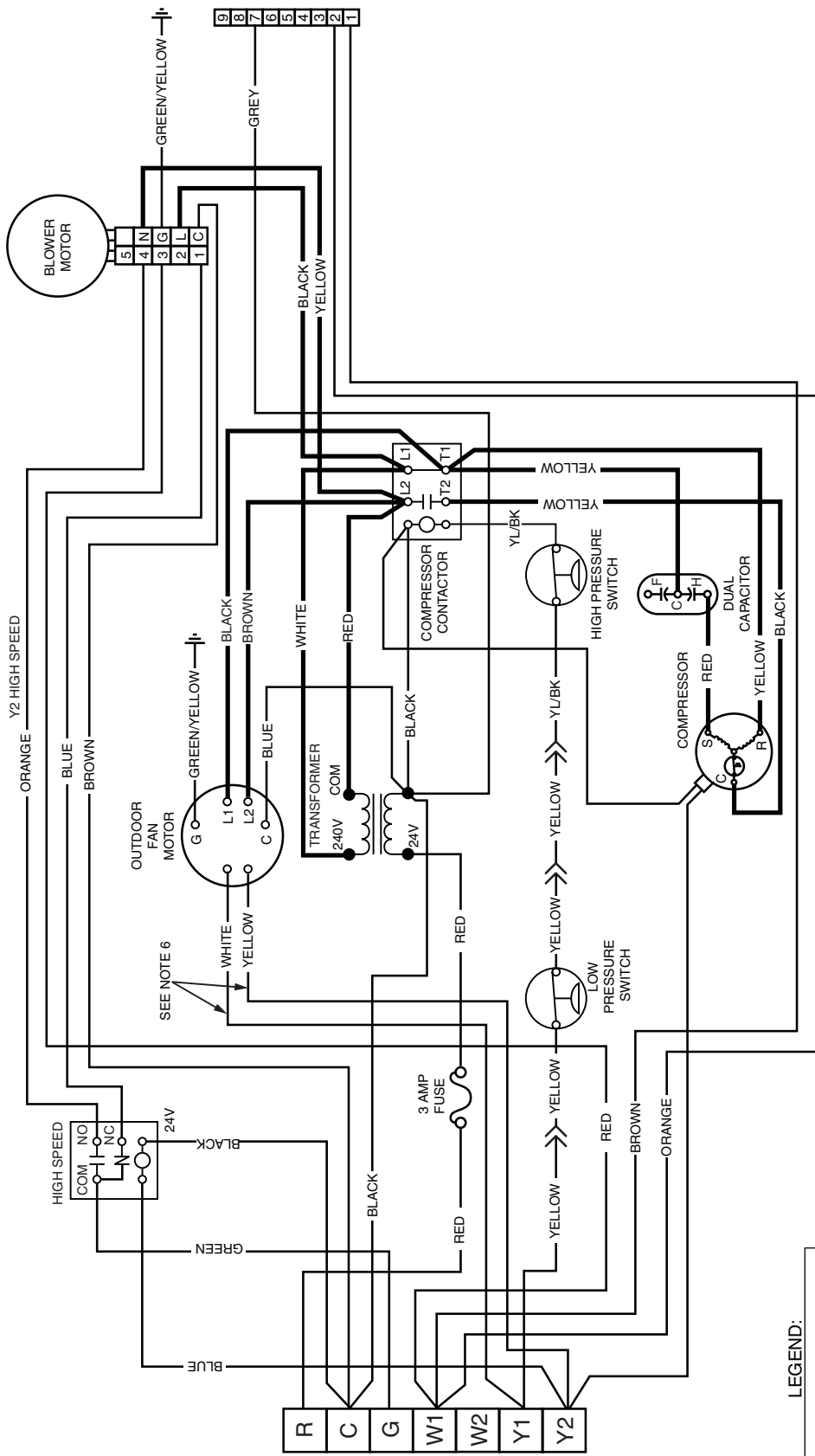

Figure 13. Wiring Diagram for 4 & 5 Ton Units

INSTALLATION / PERFORMANCE CHECK LIST

INSTALLATION ADDRESS:		
CITY _____	STATE _____	
UNIT MODEL # _____		
UNIT SERIAL # _____		
Unit Installed Minimum clearances per Figure 1 (page 4)?	YES	NO
INSTALLER NAME:		
CITY _____	STATE _____	

PROPOSITION 65 WARNING:
WARNING: This product contains chemicals known to the state of California to cause cancer.
WARNING: This product contains chemicals known to the state of California to cause birth defects or other reproductive harm.

REFRIGERATION SYSTEM		
Was unit given 24 hr warm up period for crankcase heaters (if applicable)?	YES	NO
Stage-1 Liquid Pressure (high side) _____		
Stage-1 Suction Pressure (low side) _____		
Has the owner's information been reviewed with the customer?	YES	NO
Has the Literature Package been left with the unit?	YES	NO

ELECTRICAL SYSTEM		
Electrical connections tight?	YES	NO
Line voltage polarity correct?	YES	NO
Rated Voltage: _____ VOLTS		
L1-L2 Volts: _____ VOLTS		
Has the thermostat been calibrated?	YES	NO
Is the thermostat level?	YES	NO
Is the heat anticipator setting correct? (If Applicable)	YES	NO



IMPORTANT - This product has been designed and manufactured to meet ENERGY STAR criteria for energy efficiency. However, proper refrigerant charge and proper air flow are critical to achieve rated capacity and efficiency. Installation of this product should follow the manufacturer's refrigerant charging and air flow instructions. Failure to confirm proper charge and airflow may reduce energy efficiency and shorten equipment life.

