

INSTALLATION INSTRUCTIONS

Multi-Stage, Variable Speed, Inverter Driven System with Gas Heating / Electric Cooling



Premium Model Shown

⚠ WARNING

FIRE OR EXPLOSION HAZARD

Failure to follow safety warnings exactly could result in serious injury or property damage.

– Do not store or use gasoline or other flammable vapors and liquids in the vicinity of this or any other appliance.

WHAT TO DO IF YOU SMELL GAS

- Do not try to light any appliance.
- Do not touch any electrical switch; do not use any phone in your building.
- Leave the building immediately.
- Immediately call your gas supplier from a neighbors phone. Follow the gas suppliers instructions.
- If you cannot reach your gas supplier, call the fire department.

– Installation and service must be performed by a qualified installer, service agency or the gas supplier.

⚠ AVERTISSEMENT

RISQUE D'INCENDIE OU D'EXPLOSION

Si les consignes de sécurité ne sont pas suivies à la lettre, cela peut entraîner la mort, de graves blessures ou des dommages matériels.

– Ne pas entreposer ni utiliser de l'essence ni d'autres vapeurs ou liquides inflammables dans le voisinage de cet appareil, ni de tout autre appareil.

QUE FAIRE SI UNE ODEUR DE GAZ EST DÉTECTÉE

- Ne mettre en marche aucun appareil.
- Ne toucher aucun interrupteur électrique; ne pas utiliser de téléphone dans le bâtiment.
- Quitter le bâtiment immédiatement.
- Appeler immédiatement le fournisseur de gaz en utilisant le téléphone d'un voisin. Suivre les instructions du fournisseur de gaz.
- Si le fournisseur de gaz n'est pas accessible, appeler le service d'incendie.

– L'installation et l'entretien doivent être effectués par un installateur ou une entreprise d'entretien qualifié, ou le fournisseur de gaz.

TABLE OF CONTENTS

IMPORTANT SAFETY INFORMATION.....	3	OPERATING SEQUENCE.....	18
REQUIREMENTS & CODES	4	Heating Mode.....	18
GENERAL INFORMATION.....	5	Cooling Mode.....	18
Before you install this unit	5	Low Ambient Cooling	19
Locating the Equipment.....	5	Other Speed Overrides	19
Heating Load.....	5	De-Humidification Control	19
COMBUSTION AIR & VENTING REQUIREMENTS	6	Delay Override	19
General Information.....	7	Fan Only Mode.....	19
Vent Termination	7	EQUIPMENT MAINTENANCE.....	20
CIRCULATING AIR SUPPLY	8	Cleaning of Heat Exchanger	20
Air Ducts.....	8	Cleaning of Burners.....	21
Air Filter Requirements.....	8	TROUBLESHOOTING - COOLING MODE	23
Unconditioned Spaces	8	Diagnostic Display.....	23
Acoustical Duct Work	8	Short Cycle Timer Override.....	23
UNIT INSTALLATION.....	9	Instrumentation.....	24
Packaging Removal	9	Inverter Circuit Board LEDs.....	24
Rigging & Hoisting.....	9	No Control Board Display.....	24
Clearances to Combustible Materials.....	9	Troubleshooting Individual Fault Codes.....	24
Ground Level.....	9	REPLACEMENT PARTS	26
Rooftop.....	9	HEATING COMPONENT FUNCTIONS	26
Horizontal to Downflow Conversion	9	OPTIONAL FURNACE CONTROL BOARD	
Condensate Drain	9	CONNECTIONS	26
ELECTRICAL WIRING	10	TROUBLESHOOTING - HEATING MODE.....	26
Pre-Electrical Checklist	10	FIGURES & TABLES.....	27
Grounding.....	11	Figure 10. Unit Dimensions.....	27
Line Voltage	11	Table 12. Center of Gravity & Shipping Weights	27
Thermostat / Low Voltage Connections	11	Airflow Data	28
Heat / Cool Thermostat.....	11	Table 13. Nominal Heating Airflow Rates &	
Checking Heat Anticipator Settings	12	Temperature Rises (° F)	28
Cooling Configurations.....	12	Table 14. Airflow Settings for Cooling Mode.....	28
Heating Configurations.....	12	Table 15. Airflow Settings (CFM) & Rise (° F) for	
Configuring the Variable Speed Blower	12	Heating Mode	28
Selecting Cooling Airflow.....	13	Gas Information.....	29
Selecting Heating Airflow	13	Table 16. Gas Pipe Capacities	29
Operation	13	Table 17. Gas Flow Rates	29
GAS SUPPLY & PIPING.....	13	Figure 11. Gas Valve Label	30
Leak Check	14	Electrical Information.....	31
High Altitude Conversion.....	14	Figure 12. Two-Stage, Hot Surface Ignition &	
LP/Propane Gas Conversion.....	14	Blower Control Board.....	31
START UP & ADJUSTMENTS	16	Figure 13. VSHE Blower Control Board.....	31
Pre-Start Check List.....	16	Figure 14. Interface Board in Control Panel.....	32
Start-Up Procedure	16	Table 18. Interface Board Status Codes.....	32
Air Circulation.....	16	Figure 15. R6GI Inverter Assembly.....	33
System Cooling.....	16	Figure 16. R6GI Typical Heat Exchanger Assembly.....	34
System Heating.....	16	Figure 17. Wiring Diagram (2, 3, & 4 Ton)	35
Verifying & Adjusting Temperature Rise	16	Figure 18. Wiring Diagram (5 Ton)	36
Verifying & Adjusting Firing Rate.....	17	REFRIGERANT CHARGING	37
Verifying Over-Temperature Limit Control Operation...	17	Alternate Procedure for Charging Air Conditioner in	
Verifying Burner Operation.....	17	Cooling Mode	37
Manifold Pressure Adjustment	17	Application Notes & Charging Charts.....	37
		Figure 19. Charging Chart for 2 Ton Units.....	38
		Figure 20. Charging Chart for 3 Ton Units.....	38
		Figure 21. Charging Chart for 4 Ton Units.....	39
		Figure 22. Charging Chart for 5 Ton Units.....	39
		Figure 23. Temperature Sensor Resistance Charts	40
		INSTALLATION CHECKLIST.....	44

IMPORTANT SAFETY INFORMATION

Please read all instructions before servicing this equipment. Pay attention to all safety warnings and any other special notes highlighted in the manual. Safety markings are used frequently throughout this manual to designate a degree or level of seriousness and should not be ignored. **WARNING** indicates a potentially hazardous situation that if not avoided, could result in personal injury or death. **CAUTION** indicates a potentially hazardous situation that if not avoided, may result in minor or moderate injury or property damage.

WARNING:

ELECTRICAL SHOCK, FIRE OR EXPLOSION HAZARD

Failure to follow safety warnings exactly could result in serious injury or property damage.

Improper servicing could result in dangerous operation, serious injury, death or property damage.

- Before servicing, disconnect all electrical power to furnace.
- When servicing controls, label all wires prior to disconnecting. Reconnect wires correctly.
- Verify proper operation after servicing.

AVERTISSEMENT:

RISQUE DE CHOC ÉLECTRIQUE, D'INCENDIE OU D'EXPLOSION

Le non-respect des avertissements de sécurité pourrait entraîner un fonctionnement dangereux de l'appareil, des blessures graves, la mort ou des dommages matériels.

Un entreteïn incorrect pourrait entraîner un fonctionnement dangereux de l'appareil, des blessures graves, la mort ou des dommages matériels

- Couper toute alimentation électrique au générateur d'air chaud avant de prodéder aux travaux d'entreteïn.
- Au moment de l'entreteïn des commandes, étiquetez tous les fils avant de les débrancher. S'assurez de les raccorder correctement.
- S'assurez que l'appareil fonctionne adéquatement après l'entreteïn.

WARNING:

These units are fully charged with R-410A refrigerant and ready for installation. When a system is installed according to these instructions, no refrigerant charging is required. If repairs make it necessary for evacuation and charging, it should only be attempted by qualified, trained personnel thoroughly familiar with this equipment. Some local codes require licensed installation service personnel to service this type of equipment. Under no circumstances should the homeowner attempt to install and/or service this equipment. Failure to comply with this warning could result in equipment damage, personal injury, or death.

WARNING:

Do not place combustible material on or against the unit cabinet. Do not place combustible materials, including gasoline and any other flammable vapors and liquids, in the vicinity of the unit.

WARNING:

PROPOSITION 65 WARNING: This product contains fiberglass wool, a product known to the state of California to cause cancer. Disturbing the insulation of this product during installation, maintenance, or repair will expose you to fiberglass wool.

- Breathing this material may cause respiratory irritations or may cause lung cancer.
- Fiberglass wool may also cause eye irritation, skin sensitization, or other allergic responses in susceptible individuals.
- Always wear goggles, disposable gloves, long sleeved shirt, and appropriate breathing protection when working near this insulation. If contact with skin occurs, wash immediately with soap and water. In case of contact with eyes, flush immediately with water for at least 15 minutes. Contact a physician if needed.

WARNING:

The information listed below and on the next page must be followed during the installation, service, and operation of this unit. Unqualified individuals should not attempt to interpret these instructions or install this equipment. Failure to follow safety recommendations could result in possible damage to the equipment, serious personal injury or death.

- Before beginning the installation, verify that the unit model is correct for the job. The unit model number is printed on the data label. Follow all precautions in the literature, on tags, and on labels provided with the equipment. Read and thoroughly understand the instructions provided with the

- equipment prior to performing the installation and operational checkout of the equipment.
- Never test for gas leaks with an open flame. Use a commercially available soap solution to check all connections. See [page 14](#).
 - Installation of equipment may require brazing operations. Installer must comply with safety codes and wear appropriate safety equipment (safety glasses, work gloves, fire extinguisher, etc.) when performing brazing operations.
 - This equipment is **NOT** to be used for temporary heating of buildings or structures under construction.
 - Use caution when handling this appliance or removing components. Personal injury can occur from sharp metal edges present in all sheet metal constructed equipment.
 - The installer should become familiar with the units wiring diagram before making any electrical connections to the unit. See the unit wiring label or [Figure 17 \(page 35\)](#) & [Figure 18 \(page 36\)](#).

REQUIREMENTS & CODES

- **This equipment must be installed in accordance with instructions outlined in this manual, all applicable local building codes, and the current revision of the National Fuel Gas Code (NFPA54/ANSI Z223.1) or the Natural Gas and Propane Installation Code, CAN/CGA B149.1.**
- All electrical wiring must be completed in accordance with local, state and national codes and regulations and with the National Electric Code (ANSI/NFPA 70) or in Canada the Canadian Electric Code Part 1 CSA C.22.1.
- The installer must comply with all local codes and regulations which govern the installation of this type of equipment. Local codes and regulations take precedence over any recommendations contained in these instructions. Consult local building codes and the National Electrical Code (ANSI C1) for special installation requirements.
- This equipment contains liquid and gaseous refrigerant under high pressure. Installation or servicing should only be performed by qualified trained personnel thoroughly familiar with this type equipment.
- Air Ducts must be installed in accordance with the standards of the National Fire Protection Association “Standards for Installation of Air Conditioning and Ventilation Systems” (NFPA 90A), “Standard for Installation of Residence Type Warm Air Heating and Air Conditioning Systems” (NFPA 90B), these instructions, and all applicable local codes.
- Consult [Table 13, \(page 28\)](#), [Table 14, \(page 28\)](#), & [Table 15, \(page 28\)](#), and the rating plate for the proper circulating air flow and temperature rise. It is important that the duct system be designed to provide the correct flow rates and external pressure rise. An improperly designed duct system can result in nuisance shutdowns, and comfort or noise issues.
- This unit is designed for outdoor installations only and should be located in a position as shown on [page 5](#).
- Use only with the type of gas approved for this unit. Refer to the unit rating plate.
- Provide adequate combustion and ventilation air to the unit. See [page 6](#) & [page 7](#).

- Provide adequate clearances around the combustion air intake louvers. See [Figure 1 \(page 5\)](#).
- Combustion products must be discharged outdoors. Connect this unit to an approved vent system only, as specified on [page 7](#).
- Additional codes listed below are for reference purposes only and do not necessarily have jurisdiction over local or state codes. Local codes and regulations take precedence over any recommendations contained in these instructions. Always consult with local authorities before installing any gas appliance.

Combustion & Ventilation Air

- US: National Fuel Gas Code (NFGC), Air for Combustion and Ventilation
- CANADA: Natural Gas and Propane Installation Codes (NSCNGPIC), Venting Systems and Air Supply for Appliances

Duct Systems

- US and CANADA: Air Conditioning Contractors Association (ACCA) Manual Q, Sheet Metal and Air Conditioning Contractors National Association (SMACNA), or American Society of Heating, Refrigeration, and Air Conditioning Engineers (ASHRAE) Fundamentals Handbook

Electrical Connections

- US: National Electrical Code (NEC) ANSI/NFPA 70
- CANADA: Canadian Electrical Code CSA C22.1

Gas Piping & Gas Pipe Pressure Testing

- US: NFGC and National Plumbing Codes
- CANADA: NSCNGPIC

General Installation

- US: Current edition of the NFGC and the NFPA 90B. For copies, contact the National Fire Protection Association Inc., Batterymarch Park, Quincy, MA 02269; or American Gas Association, 400 N. Capitol, N.W., Washington DC 20001 or www.NFPA.org.
- CANADA: NSCNGPIC. For a copy, contact Standard Sales, CSA International, 178 Rexdale Boulevard, Etobicoke (Toronto), Ontario, M9W 1R3 Canada

Safety

- US: (NFGC) NFPA 54–1999/ANSI Z223.1 and the Installation Standards, Warm Air Heating and Air Conditioning Systems ANSI/NFPA 90B.
- CANADA: CAN/CGA-B149.1–and .2–M00 National Standard of Canada. (NSCNGPIC)

GENERAL INFORMATION

This Single Package Gas Heating / Electric Cooling Units are designed only for outdoor rooftop or ground level installations and can be readily connected to the duct system of a home. This unit has been tested for capacity and efficiency in accordance with AHRI Standards and will provide many years of safe and dependable comfort, providing it is properly installed and maintained. With regular maintenance, this unit will operate satisfactorily year after year. Abuse, improper use, and/or improper maintenance can shorten the life of the appliance and create unsafe hazards.

To achieve optimum performance and minimize equipment failure, it is recommended that periodic maintenance be performed on this unit. The ability to properly perform maintenance on this equipment requires certain tools and mechanical skills.

Before you install this unit

- ✓ The cooling load of the area to be conditioned must be calculated and a system of the proper capacity selected. It is recommended that the area to be conditioned be completely insulated and vapor sealed.
- ✓ Check the electrical supply and verify the power supply is adequate for unit operation. Consideration should be given to availability of electric power, service access, noise, and shade. If there is any question concerning the power supply, contact the local power company.
- ✓ All units are securely packed at the time of shipment and upon arrival should be carefully inspected for damage prior to installing the equipment at the job site. Verify coil fins are straight. If necessary, comb fins to remove flattened or bent fins. Claims for damage (apparent or concealed) should be filed immediately with the carrier.
- ✓ Please consult your dealer for maintenance information and availability of maintenance contracts. Read all instructions before installing the unit.

Locating the Equipment

- Clearance in accordance with local installation codes, the requirements of the gas supplier and the manufacturer's installation instructions.
- Dégaugement conforme aux codes d'installation locaux, aux exigences du fournisseur de gaz et aux instructions d'installation du fabricant.
- A clearance of at least 36 inches from the blower access panel and from the louvered control access panel is recommended for servicing and maintenance. **Where accessibility clearances are greater than clearances to combustibles, accessibility clearances must take preference.**
- Select a solid, level position, preferably on a concrete slab, slightly above the grade level, and parallel to the home. **DO NOT PLACE UNIT UNDER THE HOME.**
- Overhead obstructions, poorly ventilated areas, and areas subject to accumulation of debris should be avoided. Do not place the unit in a confined space or recessed area where discharge air from the unit could re-circulate back through the condenser coil.

- Survey the job site to determine the best location for the packaged unit. The unit should be located with consideration of minimizing the length of the supply and return ducts. Consideration should also be given to the accessibility of fuel, electric power, service access, noise, and shade.
- Sufficient clearance for unobstructed airflow through the louvered control access panel and outdoor coil must be maintained in order to achieve rated performance. See [Figure 1](#) for minimum clearance requirements.
- The hot condenser air must be discharged up and away from the home.
- If practical, place the air conditioner and its ducts in an area where they will be shaded from the afternoon sun, when the heat load is greatest.

Heating Load

This unit should be sized to provide the design heating load requirement. Heating load estimates can be made using approved methods available from Air Conditioning Contractors of America (Manual J); American Society of Heating, Refrigerating, and Air Conditioning Engineers; or other approved engineering methods. For installations above 2,000 ft., the unit should have a sea level input rating large enough that it will meet the heating load after deration for altitude.

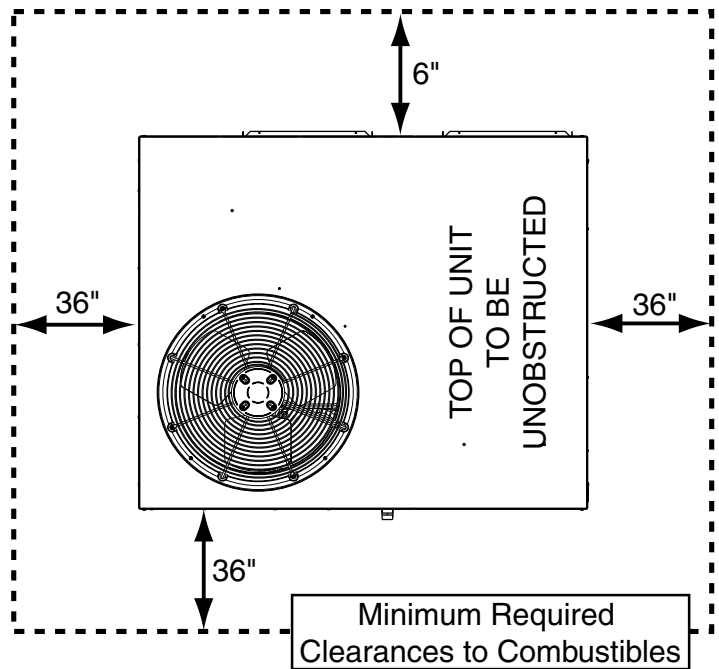

Figure 1. Clearance Requirements

COMBUSTION AIR & VENTING REQUIREMENTS

WARNING:

CARBON MONOXIDE POISONING HAZARD

Failure to follow the steps outlined below for each appliance connected to the venting system being placed into operation could result in carbon monoxide poisoning or death.

The following steps shall be followed with each individual appliance connected to the venting system being placed in operation, while all other appliances connected to the venting system are not in operation:

1. Seal any unused openings in the venting system.
2. Inspect the venting system for proper size and horizontal pitch, as required in the National Fuel Gas Code, ANSI Z223.1/NFPA 54 or the CSA B149.1, Natural Gas and Propane Installation Codes and these instructions. Determine that there is no blockage or restriction, leakage, corrosion and other deficiencies which could cause an unsafe condition.
3. As far as practical, close all building doors and windows and all doors between the space in which the appliance(s) connected to the venting system are located and other spaces of the building.
4. Close fireplace dampers.
5. Turn on clothes dryers and any appliance not connected to the venting system. Turn on any exhaust fans, such as range hoods and bathroom exhausts, so they are operating at maximum speed. Do not operate a summer exhaust fan.
6. Follow the lighting instructions. Place the appliance being inspected into operation. Adjust the thermostat so appliance is operating continuously.
7. Test for spillage from draft hood equipped appliances at the draft hood relief opening after 5 minutes of main burner operation. Use the flame of a match or candle.
8. If improper venting is observed during any of the above tests, the venting system must be corrected in accordance with the National Fuel Gas Code, ANSI Z223.1/NFPA 54 and/or CSA B149.1, Natural Gas and Propane Installation Codes.
9. After it has been determined that each appliance connected to the venting system properly vents when tested as outlined above, return doors, windows, exhaust fans, fireplace dampers and any other gas-fired burning appliance to their previous conditions of use.

AVERTISSEMENT:

RISQUE D'INTOXICATION AU MONOXYDE DE CARBONE

Si les étapes décrites ci-dessous ne sont pas suivies pour chacun des appareils raccordés au système de ventilation au moment de sa mise en marche, cela peut entraîner une intoxication au monoxyde de carbone ou la mort.

Les étapes suivantes doivent être suivies pour chacun des appareils raccordés au système de ventilation au moment de sa mise en marche, alors que tous les autres appareils raccordés au système de ventilation ne sont pas en marche :

1. Sceller toutes les ouvertures inutilisées du système de ventilation.
2. Inspecter le système de ventilation afin de vérifier si la taille et l'inclinaison par rapport à l'horizontale sont conformes aux exigences du National Fuel Gas Code, ANSI Z223.1/NFPA 54 ou du Code d'installation du gaz naturel et du propane, CSA B149.1 et à ces instructions. Vérifier qu'il n'y a pas d'obstruction ou de restriction, de fuite, de corrosion et d'autres problèmes qui pourraient entraîner une situation dangereuse.
3. Si possible, fermer toutes les portes et fenêtres du bâtiment ainsi que toutes les portes séparant l'endroit où se trouvent les appareils raccordés au système de ventilation et les autres zones du bâtiment.
4. Fermer le registre des foyers.
5. Mettre les sècheuses en marche ainsi que tous les autres appareils qui ne sont pas raccordés au système de ventilation. Mettre en marche tous les ventilateurs de tirage, comme celui des hottes de cuisine et des salles de bains, et les régler à la puissance maximale. Ne pas mettre en marche les ventilateurs d'été.
6. Suivre les instructions d'allumage. Mettre en marche l'appareil soumis à l'inspection. Régler le thermostat de manière à ce que l'appareil fonctionne en continu.
7. Vérifier la présence de fuite au niveau de l'ouverture du coupe-tirage des appareils qui en sont dotés après 5 minutes de fonctionnement du brûleur principal. Utiliser la flamme d'une allumette ou d'une bougie.
8. Si un problème de ventilation est observé pendant l'un des essais décrits ci-dessus, des correctifs doivent être apportés au système de ventilation conformément au National Fuel Gas Code, ANSI Z223.1/NFPA 54 et (ou) au Code d'installation du gaz naturel et du propane, CSA B149.1.
9. Une fois qu'il a été déterminé que chaque appareil raccordé au système de ventilation fonctionne correctement au moyen des essais décrits ci-dessus, les portes, les fenêtres, les ventilateurs, les registres de foyer et tous les autres appareils de combustion alimentés au gaz doivent être remis dans leur état initial.

General Information

⚠ WARNING:

Installation methods other than those described in the following sections must comply with the National Fuel Gas Code and all applicable local codes for providing sufficient combustion air to the furnace.

Provisions must be made during the installation of this unit that provide an adequate supply of air for combustion.

- Instructions for determining the adequacy of an installation can be found in the current revision of the NFGC (ANSI Z223.1 /NFPA54). **Consult local codes for special requirements.** These requirements are for US installations as found in the NFGC.
- The requirements in Canada (B149.1) are structured differently. Consult with B149.1 and local code officials for Canadian installations.

⚠ WARNING:

Combustion air must not be drawn from a contaminated atmosphere. Excessive exposure to contaminated combustion air will result in safety and performance related problems.

To maximize heat exchanger life, the combustion air must be free of chemicals that can form corrosive acidic compounds in the combustion gases. The recommended source of combustion air is to use clean air from outside.

DO NOT place any chemicals with flammable or caustic vapors or these other corrosive chemicals near the vent termination:

- Gasoline/Kerosene
- Permanent wave solutions
- Chlorinated waxes and cleaners
- Chlorine based swimming pool chemicals
- Water softening chemicals
- De-icing salts or chemicals
- Carbon tetrachloride
- Halogen type refrigerants
- Cleaning solvents
- Cements, glues, paint removers, varnishes, etc.
- Hydrochloric acid
- Masonry acid washing materials
- Plumbing Stack

Air openings in the door of the unit, warm air registers, and return air grilles must never be restricted. If the unit does not receive an adequate supply of air for combustion, the flame roll-out control located above the burners will open, turning off the gas supply to the burners. This safety device is a manually reset switch.

IMPORTANT NOTE

DO NOT install jumper wires across this control to defeat its function or reset the control without identifying and correcting the fault condition.

If this control must be replaced, use only factory authorized replacement parts. See the Replacement Parts List on [page 26](#).

Vent Termination

This unit has been equipped with an integral venting system and designed to operate only with this venting system. No additional venting shall be used. This unit must be vented to the outdoors.

⚠ WARNING:

This unit is intended for outdoor installation only. Do not vent the unit through a conventional venting system.

A vent cover assembly has been supplied with the unit and can be found secured to the gas controls within the control area of this unit. [Figure 2](#) shows the proper installation of the vent cover assembly over the vent outlet on the exterior of the corner panel. The fasteners used to secure the vent cover assembly have been included in the owner's package. **The vent cover assembly must be installed to assure proper operation of the unit.**

The following list summarizes the requirements for the location of the vent system termination:

- The location of the vent termination must be consistent with the National Fuel Gas Code (ANSI Z223.1) or CAN/CGA-B149 Installation Codes.
- The vent termination must be located at least 4 feet horizontally from any electric meters, gas meters, regulators, and relief equipment.
- The vent termination must be located at least 3 feet above any forced air inlet located within 10 feet.
- The vent termination must be located at least 4 feet below, 4 feet horizontally from, or 1 foot above any door, window, or gravity air inlet into any building.
- The vent termination must be located at least 1 foot above grade.
- The unit should be installed in a way that prevents any obstruction of the vent termination during accumulating snow.
- The unit installation shall avoid areas where condensate drainage may cause problems by dropping on planters or patios, etc. Also verify exhaust gases will not impinge on windows or building surfaces, which may be compromised or damaged by condensation.
- Do not install the unit such that exhaust from the vent termination is directed into window wells, stairwells, under decks, or in alcoves or similarly recessed areas. The vent termination must not be located above any public walkways.

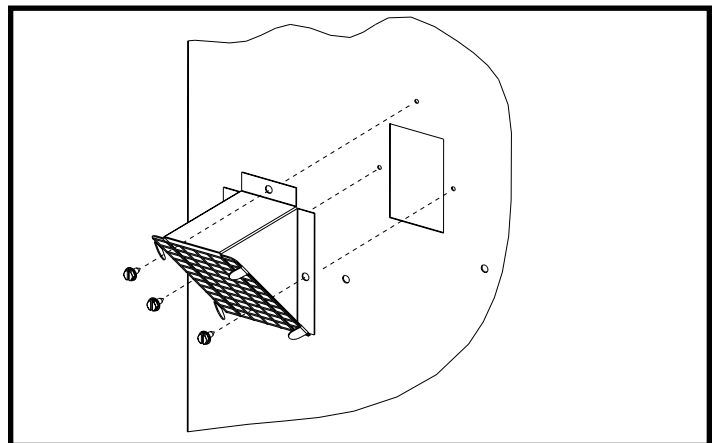

Figure 2. Vent Assembly

CIRCULATING AIR SUPPLY

WARNING:

Do not allow combustion products to enter the return air ductwork or the circulating air supply. Failure to prevent the circulation of combustion products into the living space can create potentially hazardous conditions including carbon monoxide poisoning that could result in personal injury or death.

All return ductwork must be secured to the unit with sheet metal screws. All return ductwork must be adequately sealed and all joints must be taped. When return air is provided through the bottom of the unit, the joint between the unit and the return air plenum must be air tight.

The roof curb or cement pad on which the unit is mounted must provide sound physical support of the unit with no gaps, cracks, or sagging between the unit and the curb or pad.

Return air and circulating air ductwork must not be connected to any other heat producing device such as a fireplace insert, stove, etc. Doing so may result in fire, explosion, carbon monoxide poisoning, personal injury, or property damage.

Air Ducts

This unit is designed only for use with a supply and return duct. Air ducts should be installed in accordance with the standards of the National Fire Protection Association "Standard for Installation of Air Conditioning Systems" (NFPA 90A), "Standard for Installation of Residence Type Warm Air Heating and Air Conditioning Systems" (NFPA 90B), and all applicable local codes. NFPA publications are available by writing to: National Fire Protection Association, Batterymarch Park, Quincy, ME 02269 or visit www.NFPA.org on the web.

- Design the duct work according to Manual D by the Air Conditioning Contractors of America (ACCA).
- The ducts must be properly sized not to exceed the unit maximum ESP rating at 400 scfm per nominal ton of cooling capacity.
- Duct work should be attached directly to the unit flanges for horizontal applications.
- If roof curb is installed, the ducts must be attached to the curb hangers, not the unit.
- It is recommended that the outlet duct be provided with a removable access panel. The opening should be accessible when the unit is installed in service and shall be sized so that smoke or reflected light may be observed inside the casing to indicate the presence of leaks in the heat exchanger. The cover for the opening shall be attached in a way that will prevent leaks.
- If outside air is utilized as return air to the unit for ventilation or to improve indoor air quality, the system must be designed so that the return air to the unit is not less than 50° F (10° C) during heating operation.
- If a combination of indoor and outdoor air is used, the ducts and damper system must be designed so that the return air supply to the furnace is equal to the return air supply under normal, indoor return air applications.

Air Filter Requirements

WARNING:

Never operate the unit without a filter in place. Dust and lint could accumulate on internal parts, resulting in loss of efficiency, equipment damage and possible fire.

- This unit is not supplied with air filter(s) and has no factory equipped means for accommodating internal filter(s). A suitable air filter must be installed upstream of the evaporator coil of the return air system. Refer to Table 1 for recommended filter sizes.
- All return air must pass through the filters before entering the evaporator coil. It is important that all filters be kept clean and replaced frequently to ensure proper operation of unit. Dirty or clogged filters will reduce the efficiency of the unit and result in unit shutdowns.
- Air filter pressure drop must not exceed 0.08 inches WC.
- Horizontal and downflow Installations require the air filter system be installed in the return air ductwork.

NOTE TO INSTALLER: After installing or replacing the filtration system for this unit, add the following statement on or adjacent to the filter service panel: **"Replace filter(s) installed in your system only with the same dimensional size filters that are being replaced."**

Unconditioned Spaces

All duct work passing through unconditioned space must be properly insulated to minimize duct losses and prevent condensation. Use insulation with an outer vapor barrier. Refer to local codes for insulation material requirements.

Acoustical Duct Work

Certain installations may require the use of acoustical lining inside the supply duct work.

- Acoustical insulation must be in accordance with the current revision of the Sheet Metal and Air Conditioning Contractors National Association (SMACNA) application standard for duct liners.
- Duct lining must be UL classified batts or blankets with a fire hazard classification of FHC-25/50 or less.
- Fiber duct work may be used in place of internal duct liners if the fiber duct work is in accordance with the current revision of the SMACNA construction standard on fibrous glass ducts. Fibrous duct work and internal acoustical lining must be NFPA Class 1 air ducts when tested per UL Standard 181 for Class 1 ducts.

NOMINAL COOLING (TONS)	APPROXIMATE AIR FLOW RANGE (CFM)	APPROX. FILTER AREA (SQ. IN.)*	RECOMMENDED FILTER SIZE (IN. X IN.)
2	700 - 900	450	20 x 25
3	1,000 - 1,300	625	25 x 25
4	1,500 - 1,900	915	18 x 25 (2 required)
5	1,600 - 2,000	975	20 x 25 (2 required)

* Based on velocity of 300 ft/min for disposable filters.

Table 1. Air Filter Requirements

UNIT INSTALLATION

Packaging Removal

Remove the shipping carton and User's Manual from the equipment. Take care not to damage the coil or cabinet when removing the carton. For rooftop installations, remove and discard the two supports attached beneath the unit.

Rigging & Hoisting

WARNING:

To avoid the risk of property damage, personal injury, or death, it is the rigger's responsibility to ensure that whatever means are used to hoist the unit are safe and adequate:

- The lifting equipment must be adequate for the load. Refer to [Table 12, \(page 27\)](#) for unit weights.
- The unit must be lifted from the holes in the base rails using cables or chains.
- Spreader bars are required to protect the unit and ensure even loading.
- Keep the unit in an upright position at all times. The rigging must be located outside the unit's center of gravity. Refer to [Figure 10 \(page 27\)](#) & [Figure 11 \(page 30\)](#) for locating the center of gravity.
- All panels must be securely in place during rigging and hoisting.

Clearances to Combustible Materials

These units are certified as combination heating and cooling equipment for outdoor rooftop or ground level installations. Units may be installed on combustible flooring or Class A, B, or C roofing material when used with bottom supply and return air ducts as long as the following requirements are met:

- If using bottom discharge with return air ducts a roof curb must be installed prior to unit installation. See Rigging and Hoisting section for setting of the unit.
- Sufficient clearance for unobstructed airflow through the outdoor coil must also be maintained in order to achieve rated performance. For information about locating the equipment, see [page 5](#).

Ground Level

Ground level installations must be located according to local building codes or ordinances and these requirements:

- Clearances must be in accordance with those shown in [Figure 1 \(page 5\)](#).
- A suitable mounting pad must be provided and be separate from the building foundation. The pad must be level to ensure proper condensate disposal and strong enough to support the unit's weight. The slab height must be a minimum of 2" (5cm) above grade and with adequate drainage. See [Figure 3](#).
- Remove and discard the horizontal Supply and Return duct covers located on the rear of the unit. Form duct attachment flanges by bending the sheet metal outward 90 degrees along the perforated lines.
- Firmly attach ductwork directly to these flanges with screws or other approved mechanical connections and not to the Supply/Return air panels to avoid damage to internal components of the equipment. Once completed use approved duct sealing methods to ensure an air and watertight seal is achieved.

Rooftop

Rooftop installations must be located according to local building codes or ordinances and these requirements:

- The roof must be capable of handling the weight of the unit. Reinforce the roof if necessary. For unit weights, see [Table 12, \(page 27\)](#).
- The appropriate accessory roof curb must be installed prior to unit installation. The roof curb must be square and level to ensure proper condensate drainage. See [Figure 4 \(page 10\)](#). **Please follow all instructions provided with the kit.**
- Secure roof curb or frame to roof using acceptable mechanical methods per local codes. **NOTE:** Make sure the two supports beneath the unit have been removed.

Horizontal to Downflow Conversion

The unit is shipped ready for horizontal duct connections. If down flow ducts are required, the unit must be converted following the steps below for both the supply and return ducts.

1. Remove both horizontal duct caps.
2. Locate the duct cap inside the duct openings and remove the screw holding it in place.
3. Lift the cap out of the unit. (**Hint:** The cap can be pushed up from the bottom by reaching through the fork slot).
4. Cover the horizontal duct openings with the horizontal duct caps removed earlier in step 1. The insulation will be on the indoor side.
5. Fasten the cover with screws to seal.
6. Remove and discard the two wood supports beneath the unit.

Condensate Drain

Condensate is removed from the unit through the 3/4" female pipe fitting ([Figure 5](#)) located on the front side of the unit. Install a 2 inch condensate trap in the drain line of the same size and prime with water. When connecting rigid drain line, hold the female fitting with a wrench to prevent twisting. **Do not over tighten!** Refer to local codes and restrictions for proper condensate disposal requirements.

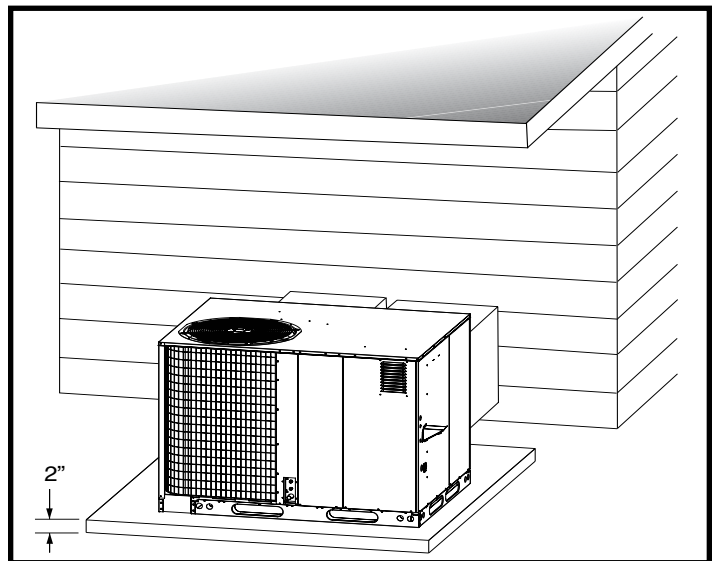

Figure 3. Ground Level Installation

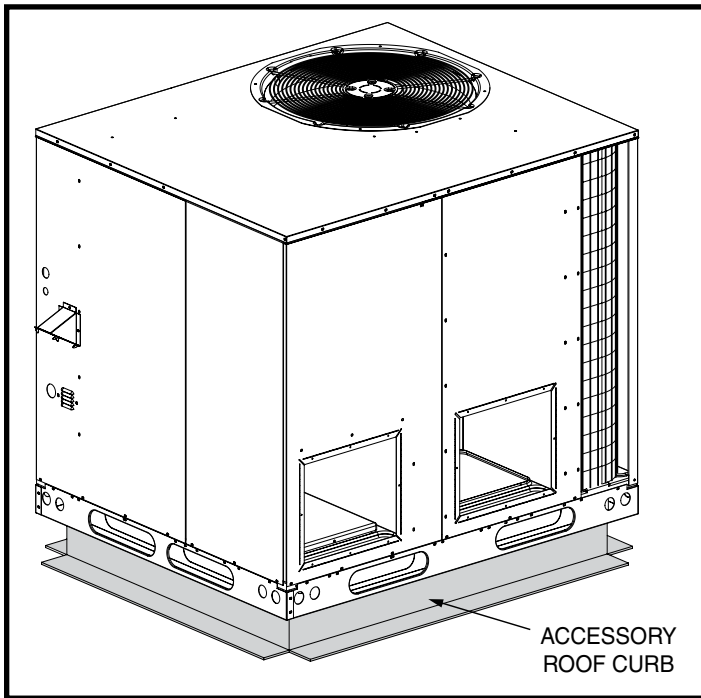

Figure 4. Roof Top Installation

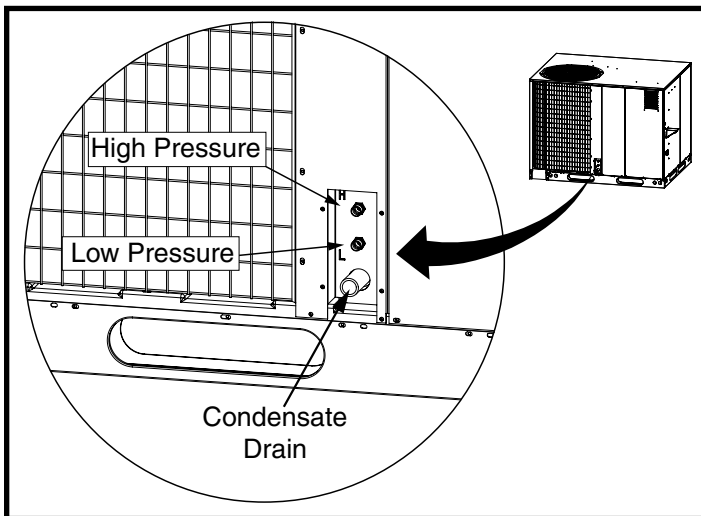

Figure 5. Condensate Drain & Service Ports

ELECTRICAL WIRING

⚠ WARNING:

ELECTRICAL SHOCK, FIRE OR EXPLOSION HAZARD

Failure to follow safety warnings exactly could result in serious injury or property damage.

Improper servicing could result in dangerous operation, serious injury, death or property damage.

- Before servicing, disconnect all electrical power to furnace.
- When servicing controls, label all wires prior to disconnecting. Reconnect wires correctly.
- Verify proper operation after servicing.

⚠ AVERTISSEMENT:

RISQUE DE CHOC ÉLECTRIQUE, D'INCENDIE OU D'EXPLOSION

Le non-respect des avertissements de sécurité pourrait entraîner un fonctionnement dangereux de l'appareil, des blessures graves, la mort ou des dommages matériels.

Un entretien incorrect pourrait entraîner un fonctionnement dangereux de l'appareil, des blessures graves, la mort ou des dommages matériels.

- Couper toute alimentation électrique au générateur d'air chaud avant de prodéder aux travaux d'entretien.
- Au moment de l'entretien des commandes, étiquetez tous les fils avant de les débrancher. S'assurer de les raccorder correctement.
- S'assurer que l'appareil fonctionne adéquatement après l'entretien.

- Electrical connections must be in compliance with all applicable local codes and ordinances, and with the current revision of the National Electric Code (ANSI/NFPA 70).
- For Canadian installations the electrical connections and grounding shall comply with the current Canadian Electrical Code (CSA C22.1 and/or local codes).

IMPORTANT NOTE:

If replacing any of the original wires supplied with the furnace, the replacement wire must be copper wiring having the same guage, voltage, and temperature rating.

Pre-Electrical Checklist

- ✓ Verify the voltage, frequency, and phase of the supply source match the specifications on the unit rating plate.
- ✓ Verify that the service provided by the utility is sufficient to handle the additional load imposed by this equipment. See [Table 2](#) or the unit wiring label for proper high and low voltage wiring.
- ✓ Verify factory wiring is in accordance with the unit wiring diagram. See [Figure 17 \(page 35\)](#) & [Figure 18 \(page 36\)](#). Verify the connections didn't loosen during shipping or installation.

MODEL NUMBER (R6GI / PPG2GI)	NOMINAL COOLING CAPACITY (TONS)	MAXIMUM HEATING INPUT	NOMINAL ELECTRICAL SUPPLY	VOLTAGE RANGE		COMPRESSOR		FAN MOTOR FLA	INDOOR BLOWER FLA	SINGLE CIRCUIT	
				MIN	MAX	RLA	LRA			MCA	MOP
E24K080X	2	80,000	208-230/60/1	187	253	11.6	N/A	2.60	3.80	20.9	30.0
E36K100X	3	100,000	208-230/60/1	187	253	16.2	N/A	2.60	3.80	26.7	40.0
E48K120X	4	120,000	208-230/60/1	187	253	17.6	N/A	3.80	7.00	32.8	50.0
E60K120X	5	120,000	208-230/60/1	187	253	24.0	N/A	3.80	7.00	40.8	60.0

NOTE: FLA = Full Load Amps; LRA = Lock Rotor amps; RLA = Rated Load Amps.

Table 2. Electrical Data

Grounding

WARNING:

The unit cabinet must have an uninterrupted or unbroken electrical ground to minimize personal injury if an electrical fault should occur. Do not use gas piping as an electrical ground!

This unit must be electrically grounded in accordance with local codes or, in the absence of local codes, with the National Electrical Code (ANSI/NFPA 70) or the CSA C22.1 Electrical Code. Use the grounding lug provided in the control box (next to the terminal block) for grounding the unit.

Line Voltage

- The line voltage to the unit should be supplied from a dedicated branch circuit containing the correct fuse or circuit breaker for the unit.
- **A properly sized branch circuit and electrical disconnect must be located within sight of and readily accessible to the unit.** This switch shall be capable of electrically de-energizing the outdoor unit. See unit data label for proper incoming field wiring. Any other wiring methods must be acceptable to authority having jurisdiction.
- Use only copper wire for the line voltage power supply to this unit. See [Table 3, \(page 12\)](#). Use proper code agency listed conduit and a conduit connector for connecting the supply wires to the unit. Use of outdoor shielded conduit (metal lined Sealtite®) is recommended.
- Provide power supply for the unit in accordance with the unit wiring diagram and the unit rating plate.
- Remove the control panel cover. Route the power and ground wires (3 wires, including earth ground) from the disconnect box to the unit.
- Connect the line voltage leads to **L1 & L2** box lugs of the high voltage terminal block, and the ground wire to the grounding lug located above the terminal block.
- Replace the control panel cover before applying power.
- Overcurrent protection must be provided at the branch circuit distribution panel and sized as shown on the unit rating label and according to applicable local codes. See the unit rating plate for maximum circuit ampacity and maximum overcurrent protection limits.
- A wiring diagram is located on the inside cover of the control access panel of the outdoor unit. The installer should become familiar with the wiring diagram ([Figure 17](#) & [Figure 18](#)) before making any electrical connections to the outdoor unit.

For 208Volt Operation Only:

- Units are shipped from the factory wired for 240 volt transformer operation. For 208V operation, remove the lead from the transformer terminal marked 240V and connect it to the terminal marked 208V.
- The inducer motor low speed resistor must be by-passed for 208 Volt operation. Remove the insulated quick connect from one side of the resistor block and connect to piggyback terminal on opposite side to complete motor circuit.

Thermostat / Low Voltage Connections

- This Gas / Electric unit is designed to operate with a 24 VAC Class II control circuit. The control circuit wiring must comply with the current provisions of the NEC (ANSI/NFPA 70) and with applicable local codes having jurisdiction. Thermostat connections should be made in accordance with the instructions supplied with the thermostat.
- These units use a special variable speed compressor to achieve a high level of efficiency in a compact frame. A 2 stage cooling / 2 stage heating 24V thermostat should be used with this unit. See [Figure 6 \(page 12\)](#).
- 24VAC control power wiring must be routed to interconnect the two-stage thermostat and the the units low voltage terminal block. Recommended wire gauge and wire lengths for typical thermostat connections are listed in [Table 4, \(page 12\)](#).
- Eight wires must be run to the control panel. **R, C, W, W2, G, Y1, Y2, and L** (if used) that originate at the thermostat. Optional **L** provides a fault indication for some thermostats.
- The thermostat should be mounted about 5 feet above the floor on an inside wall. DO NOT install the thermostat on an outside wall or any other location where its operation may be adversely affected by radiant heat from fireplaces, sunlight, or lighting fixtures, and convective heat from warm air registers or electrical appliances. Refer to the thermostat manufacturer's instruction sheet for detailed mounting information.

Heat / Cool Thermostat

2-Stage Heat / 2-Stage Cool Thermostat (Recommended):

For highest efficiency a 2 Stage Heating/Cooling thermostat is recommended for this unit. A 2 Stage Cool thermostat is required for control of the special variable speed compressor. A 2 Stage Heat thermostat will allow the gas heat to operate at a more efficient low heat condition until there is a demand for higher heat output to the conditioned space.

Single Stage Heat / 2 Stage Cool Thermostat (Optional):

A 2 Stage Cool thermostat is required for control of the special variable speed compressor. A single stage Heat thermostat can be used in conjunction with the automatic heat staging jumper on the ignition control board. The heat staging function will automatically move the unit into high heat operation at the time interval selected:

OFF = Low heat operation only and ON = 10 minute delay from low to high heat mode. See [Figure 12 \(page 31\)](#).

Connect the Red, Yellow, Green, Blue, White, and Brown (optional) low voltage thermostat wires to terminals **R**, **Y1** (1st Stage Cool), **G**, **Y2** (2nd Stage Cool), **W1** (1st Stage Heat), & **W2** (2nd Stage Heat-optional) on both the thermostat sub-base and unit low voltage terminal board. The **C** terminal (Black wire), is the 24V common wire required on some thermostat models. See [Figure 17 \(page 35\)](#) & [Figure 18 \(page 36\)](#).

COPPER WIRE SIZE — AWG (1% VOLTAGE DROP)				
SUPPLY WIRE LENGTH-FEET				SUPPLY CIRCUIT AMPACITY
200	150	100	50	
6	8	10	14	15
4	6	8	12	20
4	6	8	10	25
4	4	6	10	30
3	4	6	8	35
3	4	6	8	40
2	3	4	6	45
2	3	4	6	50
2	3	4	6	55
1	2	3	4	60

Wire Size based on N.E.C. for 60° type copper conductors.

Table 3. Copper Wire Size

THERMOSTAT WIRE GAUGE	RECOMMENDED T-STAT WIRE LENGTH (UNIT TO T-STAT)	
	2-WIRE (HEATING)	5-WIRE (HEATING/COOLING)
24	55	25
22	90	45
20	140	70
18	225	110

Table 4. Thermostat Wire Gauge

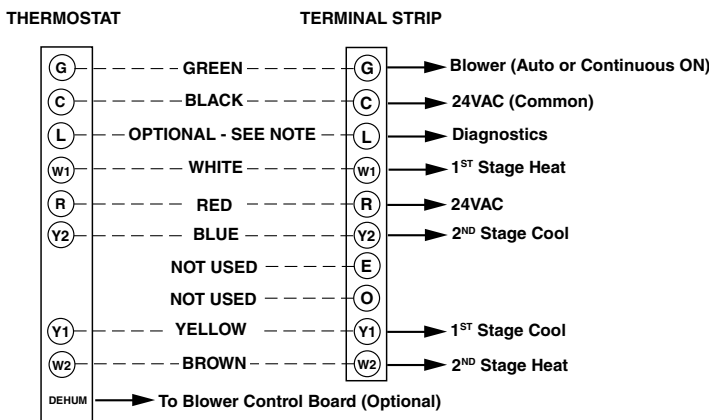

NOTE:
For use with compatible thermostats only. Refer to the thermostat manual for detailed installation and programming instructions.

Figure 6. Two Stage Heating / Two Stage Cooling Configuration

Checking Heat Anticipator Settings

- Add the current draw of the system components.
OR
- Measure the current flow on the thermostat **R-W** circuit after the circulating blower motor has started. Set the heat anticipator according to the thermostat manufacturer's instructions for heat anticipator settings.

Cooling Configurations

This unit is designed to operate 5 stages of cooling controlled by any standard 2-stage thermostat. The connection between **Y1** on the thermostat and **Y1** on the unit terminal strip energizes first stage cooling. The connection between **Y2** on the thermostat and **Y2** on the unit terminal strip energizes second stage cooling. The additional stages are controlled by run time and outdoor temperature. See [Figure 6](#).

Heating Configurations

This gas pack is factory configured for two stage gas heating operation with a two stage heating thermostat. Connect the low voltage thermostat **White** & **Brown** wires to **W1** & **W2**, between the unit low voltage terminal board and thermostat sub-base. See [Figure 6](#).

To operate with a single stage heat thermostat, only connect the low voltage thermostat **White** wire between **W1** on the unit low voltage terminal board and thermostat sub-base. Reposition the automatic heat staging jumper located on the ignition control module from OFF to ON to set a 10 minute time delay before the gas furnace will automatically move to high heat operation.

NOTE: When low fire on the gas valve is energized, the furnace operates in low fire mode at a lower blower speed and the timer begins its delay function. If the room thermostat is not satisfied before the timer activates, the furnace will stage to high fire. The inducer motor and blower will ramp to a higher speed until the thermostat is satisfied.

Configuring the Variable Speed Blower

The variable speed blower has been designed to give the installer maximum flexibility for optimizing system performance, efficiency, and comfort. It is equipped with a microprocessor-controlled variable speed motor that is pre-programmed to deliver optimum airflow in a variety of conditions and system configurations. Because the blower can be configured in many ways, it is important to read and follow all instructions carefully.

⚠ CAUTION:

To avoid personal injury or property damage, make certain that the motor leads cannot come into contact with any uninsulated metal components of the unit.

Upon initial start up, the variable speed blower must be checked so that the factory settings match the unit with the system, climatic conditions, and other system options. With the blower installed and configured properly, the furnace will gradually change speed in response to changes in system variables such as thermostat settings, duct static, filters, etc. The variable speed blower is configured by setting the eight dip switches for heating and cooling operation located on the blower control board. See [Figure 13 \(page 31\)](#) for dip switch location.

NOTES:

- For change in blower speed selection to take effect, system power must be cycled off then restored after 10 seconds.
- **Special attention must be given to dip switch location 1.** The blower control board provides four separate programs, one for each specific unit tonnage, and is designed to automatically identify the motor horsepower installed in that specific unit. 1/2 HP motor for 2 & 3 ton models and 1 HP motor for 4 & 5 Ton models. Dip switch #1 of the blower control board is factory set for the specific unit tonnage where this dip switch determines the following:
 - 0 = OFF position = 2 Ton with 1/2 HP motor
 - 1 = ON position = 3 Ton with 1/2 HP motor
 - 0 = OFF position = 4 Ton with 1 HP motor
 - 1 = ON position = 5 Ton with 1 HP motor

Selecting Cooling Airflow

Dip Switches # 5, 6, 7, & 8

The COOLING airflow is selected by setting dip switches # 5, 6, 7, & 8 on the blower control board. [Table 13, \(page 28\)](#) lists the recommended airflow values (CFM) and switch settings for each nominal system capacity. All airflows for other modes of operation are determined by these basic settings. For maximum capacity, generally, a selection near the middle or top of the CFM range for that nominal capacity is used.

NOTES:

- The CFM values listed in [Table 14 & Table 15, \(page 28\)](#) are not dependent on duct static pressure. The motor automatically compensates (within the limits of the motor) for changes in duct static pressure.
- If coil icing occurs, the basic cooling airflow selected may be too low. Verify the selected setting is within the range shown in [Table 14](#) and the system is properly charged. If icing continues, raise the selected airflow to the next higher tap.
- For maximum dehumidification and energy efficiency, select an airflow near the middle or bottom of the CFM range for that nominal capacity.
- The 2-stage cooling feature of the unit requires modulating the airflow. The unit will automatically adjust the airflow to the appropriate rate when the unit capacity changes.

Selecting Heating Airflow

Dip Switches # 2, 3, & 4

The HEATING airflow is selected by setting dip switches # 1, 2, 3, & 4 on the blower control board. [Table 15, \(page 28\)](#) lists the recommended airflow values (CFM) and switch settings for each heat exchanger capacity. All airflows are determined by these basic settings. For most applications the factory heat setting will operate at a nominal rise based on the furnace's nominal efficiency and firing input. Follow across the table row to find the switch setting and nominal air-flow. Verify the selected rise is within the specification shown on the furnace rating label or [Table 13, \(page 28\)](#).

Operation

When 24VAC is present at the **DEHUM** terminal of the blower control board the airflow requirements will be reduced to 75% of the nominal airflow requirements. If the humidity level of the conditioned space decreases during the cycle and the humidistat opens, the airflow will be restored to 100% of the selected value.

GAS SUPPLY & PIPING

WARNING:

FIRE OR EXPLOSION HAZARD

- Failure to follow safety warnings exactly could result in serious injury or property damage.
- Installation and service must be performed by a qualified installer, service agency or the gas supplier.
- Do not store or use gasoline or other flammable vapors and liquids in the vicinity of this or any other appliance.

WHAT TO DO IF YOU SMELL GAS

- Do not try to light any appliance.
- Do not touch any electrical switch; do not use any phone in your building.
- Leave the building immediately.
- Immediately call your gas supplier from a neighbor's phone. Follow the gas supplier's instructions.
- If you cannot reach your gas supplier, call the fire department.

AVERTISSEMENT:

RISQUE D'INCENDIE OU D'EXPLOSION

- Le non-respect des avertissements de sécurité pourrait entraîner des blessures graves, la mort ou des dommages matériels.
- L'installation et l'entretien doivent être effectués par un installateur qualifié, un organisme de service ou le fournisseur de gazstaller, service agency or the gas supplier.
- Ne pas entreposer ni utiliser de l'essence ni d'autres vapeurs ou liquides inflammables dans le voisinage de cet appareil, ni de tout autre appareil.

QUE FAIRE S'IL Y A UNE ODEUR DE GAZ

- Ne pas tenter d'allumer aucun appareil.
- Ne toucher à aucun interrupteur électrique; n'utiliser aucun téléphone dans le bâtiment.
- Évacuer l'immeuble immédiatement.
- Appeler immédiatement le fournisseur de gaz en employant le téléphone d'un voisin. Respecter à la lettre les instructions du fournisseur de gaz.
- Si personne ne répond, appeler le service des incendies.

- All gas piping must be installed in compliance with local codes and utility regulations. In the absence of local codes the gas line installation must comply with the latest edition of the National Fuel Gas Code ANSI Z223.1 or CAN/CGA B149 Installation Codes.
- Some local codes require the installation of a manual main shut-off valve and ground joint union external to the furnace. The shut-off valve should be readily accessible for service and/or emergency use. Consult the local utility or gas supplier for additional requirements regarding placement of the manual main gas shut-off. See [Figure 7 \(page 15\)](#).

- The manifold pressure must be set to the appropriate value for your installation. Refer to the Manifold Pressure Adjustment section (page 17) for adjustment instructions.
- Gas piping must never run in or through air ducts, chimneys, gas vents, or elevator shafts.
- Compounds used to seal joints on gas piping must be resistant to the actions of LP propane gas.
- The main gas valve and main power disconnect to the furnace must be properly labeled by the installer in case emergency shutdown is required.
- An 1/8 inch NPT plugged tap must be installed in the gas line immediately upstream of the gas supply connection to the furnace for use when measuring the gas supply pressure. The plug should be readily accessible for service use.
- A drip leg should be installed in the vertical pipe run to the unit (Figure 7).

This unit only has right side gas entry. When connecting the gas, provide clearance between the gas supply line and the entry hole in the unit's casing to avoid unwanted noise and/or damage to the unit. A typical gas service hookup is shown in Figure 7.

Table 16 (page 29) lists gas pipe capacities for standard pipe sizes as a function of length in typical applications based on nominal pressure drop in the line.

Leak Check

 WARNING:
FIRE OR EXPLOSION HAZARD
Failure to follow safety warnings exactly could result in serious injury or property damage.
Never test for gas leaks with an open flame. Use a commercially available soap solution made specifically for the detection of leaks to check all connections. A fire or explosion may result causing property damage, personal injury or loss of life.

 AVERTISSEMENT:
RISQUE D'INCENDIE OU D'EXPLOSION
Si les consignes de sécurité ne sont pas suivies à la lettre, cela peut entraîner la mort, de graves blessures ou des dommages matériels.
Ne jamais vérifier la présence de fuites de gaz au moyen d'une flamme nue. Vérifier tous les raccords en utilisant une solution savonneuse commerciale conçue spécialement pour la détection de fuites. Un incendie ou une explosion risque de se produire, ce qui peut entraîner la mort, des blessures ou des dommages matériels.

After the gas piping to the unit is complete, all connections must be tested for gas leaks. This includes pipe connections at the main gas valve, emergency shutoff valve and other gas connectors. A soap and water solution can be applied on each joint or union using a small paintbrush. If any bubbling is observed, the connection is not sealed adequately and must be retightened. Repeat the tightening and soap check process until bubbling ceases.

- If pressure testing the gas supply lines at pressures greater than 1/2 psig (14 inches WC), the unit must be disconnected from the gas supply piping system to prevent damage to the gas valve.
- If the test pressure is less than or equal to 1/2 psig (14 inches WC), the unit must be isolated from the gas supply line by closing the manual shut-off valve.

High Altitude Conversion

Conversion of this unit must be performed by qualified service personnel, using only approved parts. All installations must be made in accordance with the National Fuel Gas Code and/or local jurisdiction codes.

High altitude conversion can be field performed by a simple adjustment of manifold pressure or a change of the orifices (if necessary) depending on type of gas being utilized. The changes required depend on the installation altitude and the heating value of the gas (based on sea level) which can be obtained from your local gas utility. The heating value of gas at high altitude is always lower than the sea level heating value. The heating values listed in Table 5 & Table 6, (page 15) are based on sea level values.

WARNING:

The reduction of input rating necessary for high altitude installation may only be accomplished with factory supplied orifices. Do not attempt to drill out orifices in the field. Improperly drilled orifices may cause fire, explosion, carbon monoxide poisoning, personal injury or death.

If installing this unit above 2,000 feet, the input rate must be reduced 4% per 1,000 feet of altitude (Example: 12% at 3,000 feet, 16% at 4,000 feet, etc). **NOTE:** Deration is necessary to compensate for low atmospheric pressure at high altitudes.

For altitudes between 5,000 and 10,000 feet above sea level, the unit can be converted by changing the orifice and adjusting the furnace manifold pressure. See Table 5 for the correct orifice and manifold pressure setting. **NOTE:** Each unit has specific orifices.

LP/Propane Gas Conversion

WARNING:

This unit was equipped at the factory for use with natural gas only. A special kit, supplied by the manufacturer, is required to convert the unit to operate on LP/propane gas. Failure to use the proper conversion kit can cause fire, explosion, property damage, carbon monoxide poisoning, personal injury, or death.

IMPORTANT NOTE:

When converting this low NOx unit from natural gas to propane (LP) gas, it is necessary to remove the NOx baffles.

Conversion of this equipment to LP/Propane gas must be made by qualified service personnel, using approved factory parts. Conversion to LP can be accomplished by replacing the natural gas orifices with the appropriate LP/Propane orifices and then adjusting the manifold pressure (page 17). Conversion to LP/Propane (sea level and high altitude)

is detailed in the installation instructions provided with the conversion kit. **Please follow the instructions provided in each kit.** Approved conversion kits are:

- The United States LP/Propane Gas Sea Level and High Altitude Conversion Kit is for LP/propane conversion in the United States at altitudes between zero and 10,000 ft. above sea level.
- The Canadian LP/Propane Gas Sea Level and High Altitude Conversion Kit is for LP/propane conversions in Canada at altitudes between zero and 4,500 ft. above sea level.

For LP applications, refer to [Table 6](#) for the correct orifice size and furnace manifold pressure. NOTE: Each unit has specific orifices.

After changing the orifices, it is required that you measure the gas input rate by clocking the gas meter and using the local gas heating value. See [Verifying & Adjusting the Firing Rate](#) section on [page 17](#).

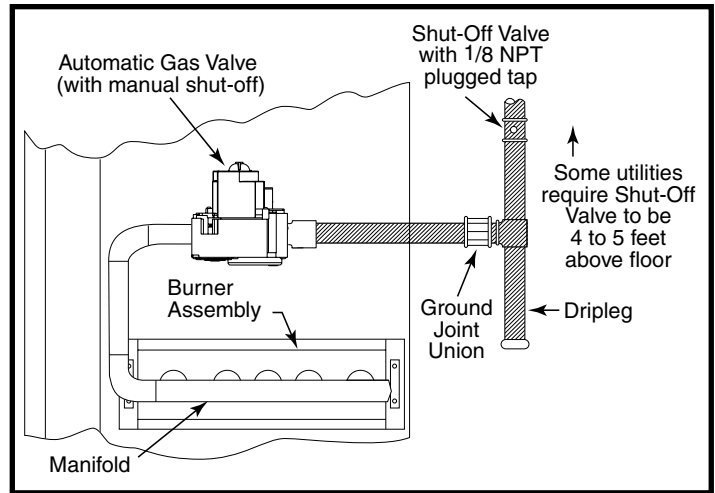

Figure 7. Typical Gas Hookup - Right Side Entry

R6GI-EX24K080X & R6GI-E36K100X MANIFOLD PRESSURE FOR NATURAL GAS INSTALLATIONS (IN W.C.)				
ALTITUDE ABOVE SEA LEVEL	HEATING VALUE BTU/CU. FT			ORIFICE SIZE
	800 TO 899 FT	900 TO 999 FT	1,000 TO 1,100 FT	
Zero to 1,999 Ft.	3.5	3.5	3.5	45
2,000 to 2,999 Ft.	3.2	3.2	3.2	45
3,000 to 3,999 Ft.	2.9	2.9	2.9	45
4,000 to 4,999 Ft.	2.7	2.7	2.7	45
5,000 to 5,999 Ft.	3.4	3.4	3.4	48
6,000 to 6,999 Ft.	3.1	3.1	3.1	48
7,000 to 7,999 Ft.	2.9	2.9	2.9	48
8,000 to 8,999 Ft.	2.7	2.7	2.7	48
9,000 to 10,000 Ft.	2.6	2.6	2.6	48

R6GI-EX24K080X & R6GI-E36K100X MANIFOLD PRESSURE FOR LP/PROPANE INSTALLATIONS (IN W.C.)		
ALTITUDE ABOVE SEA LEVEL	MANIFOLD PRESSURE	ORIFICE SIZE
Zero to 1,999 Ft.	10	55
2,000 to 2,999 Ft.	9.2	55
3,000 to 3,999 Ft.	8.5	55
4,000 to 4,999 Ft.	8	55
5,000 to 5,999 Ft.	10	56
6,000 to 6,999 Ft.	9.2	56
7,000 to 7,999 Ft.	8.5	55
8,000 to 8,999 Ft.	8	56
9,000 to 10,000 Ft.	8	56

R6GI-EX48K120X & R6GI-EX60K120X MANIFOLD PRESSURE FOR NATURAL GAS INSTALLATIONS (IN W.C.)				
ALTITUDE ABOVE SEA LEVEL	HEATING VALUE BTU/CU. FT			ORIFICE SIZE
	800 TO 899 FT	900 TO 999 FT	1,000 TO 1,100 FT	
Zero to 1,999 Ft.	3.5	3.5	3.5	43
2,000 to 2,999 Ft.	3.2	3.2	3.2	43
3,000 to 3,999 Ft.	2.9	2.9	2.9	43
4,000 to 4,999 Ft.	2.7	2.7	2.7	43
5,000 to 5,999 Ft.	3.5	3.5	3.5	45
6,000 to 6,999 Ft.	3.2	3.2	3.2	45
7,000 to 7,999 Ft.	3.0	3.0	3.0	45
8,000 to 8,999 Ft.	2.8	2.8	2.8	45
9,000 to 10,000 Ft.	2.6	2.6	2.6	46

R6GI-EX48K120X & R6GI-EX60K120X MANIFOLD PRESSURE FOR LP/PROPANE INSTALLATIONS (IN W.C.)		
ALTITUDE ABOVE SEA LEVEL	MANIFOLD PRESSURE	ORIFICE SIZE
Zero to 1,999 Ft.	10	54
2,000 to 2,999 Ft.	9.2	54
3,000 to 3,999 Ft.	8.5	54
4,000 to 4,999 Ft.	8	54
5,000 to 5,999 Ft.	9	55
6,000 to 6,999 Ft.	8.2	55
7,000 to 7,999 Ft.	10	56
8,000 to 8,999 Ft.	9	56
9,000 to 10,000 Ft.	8.2	56

Table 5. Manifold Pressure Setting for Natural Gas

Table 6. Manifold Pressure Setting for LP Gas

START UP & ADJUSTMENTS

Pre-Start Check List

- ✓ Verify the unit is level and allows proper condensate drainage.
- ✓ Verify all clearance requirements are met and there is free airflow to and from the outdoor coil.
- ✓ Verify that the duct work is sealed to prevent air leakage.
- ✓ Verify that the line voltage power leads are securely connected and the unit is properly grounded.
- ✓ Verify that the low voltage wires are securely connected to the correct leads on the low voltage terminal strip.
- ✓ Verify that the gas line service pressure does not exceed 10.0 inches WC (0.36 psig), and is not less than 4.5 inches WC (0.16 psig) for natural gas. For LP gas the line service pressure must not exceed 14 inches WC (0.51 psig) and must not be less than 11.0 inches WC (0.40 psig).
- ✓ Verify that the flame roll-out control is closed. If necessary, press the red button to reset the control. **DO NOT** install a jumper wire across the control to defeat its function. If the control reopens upon start-up, **DO NOT** reset the control without identifying and correcting the fault condition which caused the control to trip.
- ✓ Verify that the gas line has been purged and all connections are leak tight.
- ✓ Verify that all exterior panels are replaced and securely fastened.
- ✓ Verify that the outdoor fan turns freely.
- ✓ Verify that the power supply branch circuit overcurrent protection is sized properly.
- ✓ Verify that the thermostat is wired correctly. The thermostat function switch should be set to OFF and the thermostat fan switch should be set to AUTO.

Start-Up Procedure

- Check all electrical wiring for loose connections and tighten as required.
- Check unit for return air filters and condensate trap.
- Close all electrical disconnects to energize the system.

Air Circulation

Leave the thermostat system mode on OFF and set the fan mode to ON. Blower will run continuously. Check the air delivery at the supply registers and adjust register openings for balanced air distribution. Examine ductwork for leaks or obstruction if insufficient air is detected. Set the thermostat fan mode to AUTO. The blower will stop running. NOTE: When fan ON is selected, the blower will operate at 50% of selected airflow when no call for heating or cooling is present.

System Cooling

1. Set the thermostat's system mode to COOL and the fan mode to AUTO. Lower the thermostat temperature setpoint one degree below room temperature and verify the Operating Sequence (page 18). Verify that the compressor and outdoor fan motor are energized.

NOTE: System will energize **Y1** and run at stage 1 intermediate speed.

2. Feel the air being circulated by the indoor blower and verify that it is cooler than ambient temperature. Listen for any unusual noises. If unusual sounds occur, determine the source of the noise and correct as necessary.
3. After determining the system is operating properly, wait 2 minutes then lower the thermostat temperature setpoint an additional 3-4 degrees until the system energizes **Y1 & Y2** and runs at stage-2 nominal rating speed. Verify operating

codes as indicated by the two digit display on the interface board. See Figure 14 (page 32) and Table 17, (page 29).

4. After the unit has run for approximately 5 minutes, set the thermostat above room temperature. Verify the outdoor fan and compressor stop running. The indoor blower will stop after a 60 second delay.

System Heating

1. Set the thermostat to the lowest setting.
2. Follow the procedures given on the operating instruction label in this installation instructions or attached inside the louvered control access panel.
3. Set the thermostat one degree above room temperature and verify the sequence of operation. See Operating Sequence section (pages 19 & 20.)
4. Verify that the compressor and outdoor fan motor are not energized.
5. After determining the system is operating properly, after 1-2 minutes raise the thermostat temperature set point an additional 3-4 degrees until the heating system moves into 2nd stage or high heat operating mode. The gas valve will energize to high heat mode while the induced draft motor and indoor blower motor both increase in speed.
6. After the unit has run for approximately five minutes, set the thermostat below room temperature. Verify the shutdown sequence; steps 10 -12 in the Operating Sequence section (page 18).

Verifying & Adjusting Temperature Rise

Verify the temperature rise through the unit is within the range specified on the unit data label for both high and low firing rates. Temperature rises outside the specified range could result in premature heat exchanger failure.

1. Place thermometers in the return and supply air stream as close to the unit as possible. The thermometer on the supply air side must be shielded against direct radiation from the heat exchanger to avoid false readings.
2. Adjust all registers and duct dampers to the desired position. Run the unit for 10 to 15 minutes before taking any temperature readings. The temperature rise is the difference between the supply and return air temperatures.

NOTE: For typical duct systems, the temperature rise will fall within the range specified on the data label (with the blower speed at the factory recommended setting) shown in Table 13, (page 28). If the measured temperature rise falls outside the specified range, it may be necessary to change the blower speed. Lowering the blower speed increases the temperature rise and a higher speed decreases the temperature rise.

The unit is equipped with a variable speed motor. Heating and cooling speed selection is made by changing the dip switch settings on the blower control board located in the unit control box. Refer to Configuring the Variable Speed Blower Section (page 12) for additional information.

NOTE: For change in blower speed selection to take effect, system power must be cycled off then restored after 10 seconds.

The Variable Speed Blower (VSB) Control Board (Figure 13 (page 31)) is designed with built in delay profiles for start up and shut down of the system. Refer to the Operating Sequence section (page 18) for more details.

Verifying & Adjusting Firing Rate

CAUTION:

Do not re-drill the burner orifices. If the orifice size must be changed, use only new orifices.

The firing rate must be verified for each installation to prevent over-firing of the furnace. **The firing rate must not exceed the rate shown on the unit data label.** To determine the firing rate, follow the steps below:

1. Obtain the gas heating value (HHV) from the gas supplier.
2. Shut off all other gas fired appliances.
3. Start the unit in heating mode and allow it to run for at least 3 minutes.
4. Measure the time (in seconds) required for the gas meter to complete one revolution.
5. Convert the time per revolution to cubic feet of gas per hour using [Table 17, \(page 29\)](#).
6. Multiply the gas flow rate in cubic feet per hour by the heating value of the gas in Btu per cubic foot to obtain the firing rate in Btu per hour. See Example.

Example:

- Time for 1 revolution of a gas meter with a 1 cubic foot dial = 40 seconds.
- From [Table 17](#), read 90 cubic feet gas per hour.
- Local heating value of the gas (obtained from gas supplier) = 1,040 Btu per cubic foot.
- Input rate = 1,040 x 90 = 93,600 Btuh.

7. Adjust the manifold pressure if necessary. See [Manifold Pressure Adjustment](#) instructions. For additional information about elevations above 2,000 feet, see [page 14](#).

Verifying Over-Temperature Limit Control Operation

1. Verify the louvered control access panel is in place and that there is power to the unit.
2. Block the return airflow to the unit by installing a close-off plate in place of or upstream of the filter.
3. Set the thermostat above room temperature and verify the units operating sequence ([page 18](#)).

NOTE: The over-temperature limit control should turn off the gas valve within approximately four minutes (exact time depends on the efficiency of the close-off when blocking the return air). The circulating air and combustion blowers should continue to run when the over-temperature limit control switch opens.

4. Remove the close-off plate immediately after the over-temperature limit control opens. If the unit operates for more than four minutes with no return air, set the thermostat below room temperature, shut off power to the unit, and replace the over-temperature limit control.

Verifying Burner Operation

WARNING:

Uninsulated live components are exposed when louvered control access panel is removed.

1. Remove the louvered control access panel and verify there is power to the unit.
2. Set thermostat above room temperature and observe the ignition sequence. **NOTE:** The burner flame should carry over immediately between all burners without lifting off, curling, or floating. The flames should be blue, without yellow tips. Make sure the flame is drawn into the center of the heat exchanger tube. In a properly adjusted burner assembly, the flame bends down and to the right at the end of the heat exchanger tube. The end of the flame will be out of sight around the bend.
3. After validating flame characteristics, set the thermostat below room temperature and verify the burner flame extinguishes completely.

Manifold Pressure Adjustment

The manifold pressure must be set to the appropriate value for your installation. To adjust the manifold pressure:

1. Obtain the required manifold pressure setting. Use [Table 5](#) for natural gas or [Table 6, \(page 15\)](#) for LP/propane gas. **NOTE:** The values listed in the tables are based on sea level values. At higher altitudes, the heating value of gas is lower than the sea level heating value.
2. Remove the regulator cap. Turn the high fire adjusting screw clockwise to increase the pressure or counterclockwise to reduce the pressure. See [Figure 9 \(page 22\)](#) for adjusting screw locations.
3. Replace the regulator cap after adjustments are complete.

OPERATING SEQUENCE

The operating sequences for the heating, cooling, and fan modes are described below. Refer to the field and furnace wiring diagrams: [Figure 17 \(page 35\)](#) & [Figure 18 \(page 36\)](#).

Heating Mode

1. On a call for 1st stage heat, the thermostat closes and applies 24 VAC to terminal **W1** on the control board.
2. Safety Circuit Proving - The control board verifies continuity through the 24VAC limit control circuit. If the high temperature limit switch and flame roll-out switch are closed and both the high and low vent pressure switches are open, the control board will then begin pressure switch proving. If an open limit is detected, the control board will energize the indoor blower motor and operate it continuously while the limit switch circuit is open. All other system functions will be inoperable until the limit circuit closes. While the limit circuit is open, the control will display *Open Limit Switch Fault*. See [Table 10, \(page 26\)](#).
3. The furnace control checks for continuity (24 VAC) across the pressure switch. If either the high or low pressure switch is closed, the heat mode sequence will not continue. If either remains closed, the control will display a *Pressure Switch Closed with Inducer Off Fault* until the fault condition clears.
4. Pressure Switch Proving - The control energizes the induced draft motor on High speed and waits for the high and low pressure vent switch to close. If the low pressure switch does not close within 12 seconds, the control will display a *Pressure Switch Open with Inducer On Fault*. If the pressure switches do not close before 60 seconds expires, the control will de-energize the inducer for 5 minutes and continue to display a *Pressure Switch Open with Inducer On Fault* during the 5 minute inducer off period. After the inducer has been off for 5 minutes, the control energizes the inducer motor and restarts the 60 second pressure switch proving period.
5. Pre-Purge - If the low pressure switch closes the control runs the inducer on high speed for a 30 second pre-purge time while monitoring the thermostat call for heat, limit switch circuit, high and low pressure switch, and flame sense.
6. Igniter Warm Up - When the 30 second pre-purge time has elapsed, the control begins the Hot Surface Ignition (HSI) warm-up as follows:

Initial Power up: After 30 seconds of igniter warm-up, the gas valve will open. The igniter circuit will stay energized for 3 seconds after the gas valve opens.

After Initial Power up: The control has a programmed adaptive ignition feature which varies the warm-up period as follows: If ignition is successful the warm-up is *reduced* by 3 seconds on each subsequent call for heat until ignition failure occurs. Upon ignition failure, the warm-up is *increased* by 3 seconds on the next try. If successful, the timing remains fixed at this level. In general, whenever ignition failure occurs the warm-up interval is increased by 3 seconds on the next try. And if successful, it remains there. Minimum and maximum warm-up time limits are set at 9 and 54 seconds.

7. Flame Proving / Ignition / Low Heat Operation - The furnace control must prove flame via the flame sensor 5 seconds after the high main gas valve is energized.
 - If flame is sensed, burners are on and the igniter cools off. The yellow LED will be lit.
 - If no flame is sensed, the gas valve closes immediately and the inducer continues to run on high. A second trial for ignition (step 6) begins. If no flame is sensed on the fifth try for ignition, the furnace control is locked and the control will display *1 Hour Lockout Fault*. The

thermostat must be opened for at least 10 seconds to reset the furnace control after a lock out. Otherwise, the furnace will attempt another ignition sequence in 1 hour.

Low Fire Heat (Stage 1): If flame is present at the end of the trial for ignition time, the control leaves High main gas valve energized and inducer motor on High speed for the first 15 seconds, and begins the heat blower 22 second on delay. Control inputs are continuously monitored while the call for heat remains. The control will always energize the gas valve on High fire with the inducer on High speed for the first 15 seconds of any heating cycle. After this 15 second period, the control switches the gas valve to Low fire and inducer to Low speed if no second stage (W2) demand is present.

8. Blower Start-Up - After flame is proven, the furnace control energizes the circulating air blower after 22 seconds. The blower will then ramp up to the airflow selected for heating.
9. High Heat Staging (with 2 Stage Heat Thermostat) - Unit will always start in High heat operation. See step 7 for start up sequence. After the initial 15 second start up sequence is satisfied, the control will move to Low heat and wait for a **W2** call from a 2-stage thermostat. After a second stage heat demand is present (W2 energized), the gas valve will open to High heat mode increasing the flow of gas to the burners while the inducer and blower motor ramp to high speed.

Single Stage Heat Thermostat with Automatic Heat Staging

- Automatic heat staging allows the unit to operate as a two stage gas furnace with the use of a single stage heating thermostat. With the ignition control AUTO HEAT STAGE jumper repositioned from the OFF position to the ON position, the gas furnace will automatically switch to High heat mode of operation after a 10 minute delay. The induced draft motor and blower motor will both ramp to high speed. See [Figure 12 \(page 31\)](#).

10. When the thermostat has been satisfied, gas valve is de-energized.
11. The inducer motor is de-energized after a 30 second post purge.
12. The circulating air blower will remain energized for approximately 120 - 150 seconds after the demand for heat is no longer present.
13. Abnormal Conditions - If a limit switch opens during heating operation the gas valve is de-energized immediately. The control de-energizes the induced draft motor and runs the indoor blower motor continuously while the limit switch is open.

Cooling Mode

Before the first start after power-up and between cycles there will always be a 5 minute (re)start delay imposed. With a call for cooling and before the compressor is turned on, the outdoor fan will run for 1 minute to assure that the outdoor temperature measurement is close to that of the ambient air. The compressor will then ramp up to a speed selected by the capacity control scheme.

The unit is a true variable speed unit. Normally the compressor will operate at one of 5 speeds in cooling, each predetermined for a balance of optimum efficiency and capacity. The outdoor fan motor and indoor blower will also operate at multiple speeds, following the compressor.

For cooling mode, the speeds used will depend on several factors, including:

- Whether first or second stage operation is called for by the thermostat (which must be two stage-capable),
- Outdoor ambient temperature.
- The length of time the equipment has been operating during the current cycle
- The operating speed history, for both the current and the previous operating cycles.

For example, with a first stage call in cooling, if the setpoint was satisfied quickly (within 20 minutes), the unit will restart the next time at a lower speed. At a low or intermediate speed, if the setpoint is not satisfied within 45 minutes, the speed will be increased. If the unit cycles off after having a speed increase, the entire next cycle will be at the higher speed. Also, the outdoor fan will run for an extra minute after the compressor shuts off at the end of a cycle.

The actual current operating compressor speed can be determined by checking the 2-character display on the interface board. Refer to [Figure 14 \(page 32\)](#), [Figure 15 \(page 33\)](#), and [Table 18, \(page 32\)](#). Control operation is protected under U.S patent number US 8,011,199 B1.

The blower speeds for the various cooling stages are programmed and controlled in accordance with compressor speeds. It is possible to adjust blower airflow if required by application, in which case the controller will adjust all speeds according to the adjusted nominal speed. The airflow is set by DIP switches on the blower control board, providing one flow for second stage compressor speeds and a lower flow for first stage compressor speeds.

Low Ambient Cooling

System control will modulate to allow safe operation in low outdoor temperatures by controlling blower CFM, compressor speed, and fan speed until an outdoor temperature is less than 50° F. If there is a call for air conditioning when the temperature drops below this point, the unit will shut down (if running), and diagnostic code $\overline{29}$ and status code \overline{LE} will be displayed on the interface board. Once this lockout is in effect, the unit can resume cooling after ambient temperature has risen again above 55° F.

Other Speed Overrides

When ambient temperature is high, exceeding 105° F, the compressor speed may be reduced to limit current draw or inverter component temperature. Whether or not this occurs

and to what degree the speed is reduced depends upon the unit model and the specific operating conditions as detected by the inverter. Speed will return to the normal value when the high current or temperature condition is relieved. In addition, any time outdoor ambient temperature exceeds 100° F, the fan will operate at its maximum speed.

De-Humidification Control

If installing a humidistat, install it in the return air duct as directed in the installation instructions included in the accessory kit. Run the humidistat wiring through the low-voltage wire entrance in the packaged unit and connect one side of the humidistat to the **R** terminal of the low voltage field connection board & the other side to the **DEHUM** terminal located on the blower control board. Wire the humidistat to close on rise in humidity.

For dehumidification, the Dehum input on the VSHE board can be used to control this function. If the Dehum input is active and the unit is operating in second stage cooling, the following will happen. The suction line temperature sensor is used for coil temperature.

- The blower CFM is 75% of cooling value for the operating speed.
- If coil temperature is less than 37° F for 30 seconds, then blower CFM is set to 85% of cooling value. If coil temperature rises above 37° F for 5 minutes, then blower runs at 75% of cooling value.
- If coil temperature is less than 35° F for 30 seconds, then blower CFM is set to 100% of cooling value. If coil temperature rises to between 35° and 37° F for 5 minutes, then blower CFM is set to 85% of cooling value. If coil temperature rises above 37° F for 5 minutes, then blower CFM is set to 75% of cooling value.

Delay Override

When performing startup tests or troubleshooting, the 5 minute startup delay can be skipped by shorting the two J4 Test pins indicated in [Figure 14](#) for about 1 second while the compressor is off and waiting to start.

NOTE: This will also clear the faults stored in memory.

Fan Only Mode

1. On a call for fan only operation, the thermostat applies 24 VAC to the **G** terminal on the furnace control board.
2. The circulating air blower ramps to 1/2 of the selected airflow.

EQUIPMENT MAINTENANCE

WARNING:

ELECTRICAL SHOCK, FIRE OR EXPLOSION HAZARD

Failure to follow safety warnings exactly could result in serious injury or property damage.

Improper servicing could result in dangerous operation, serious injury, death or property damage.

- Before servicing, disconnect all electrical power to furnace.
- When servicing controls, label all wires prior to disconnecting. Reconnect wires correctly.
- Verify proper operation after servicing.

AVERTISSEMENT:

RISQUE DE CHOC ÉLECTRIQUE, D'INCENDIE OU D'EXPLOSION

Le non-respect des avertissements de sécurité pourrait entraîner un fonctionnement dangereux de l'appareil, des blessures graves, la mort ou des dommages matériels.

Un entreteïn incorrect pourrait entraîner un fonctionnement dangereux de l'appareil, des blessures graves, la mort ou des dommages matériels

- Couper toute alimentation électrique au générateur d'air chaud avant de prodéder aux travaux d'entreteïn.
- Au moment de l'entreteïn des commandes, étiquetez tous les fils avant de les débrancher. S'assurer de les raccorder correctement.
- S'assurer que l'appareil fonctionne adéquatement après l'entreteïn.

CAUTION:

Use care when removing parts from this unit. Personal injury can result from sharp metal edges present in all equipment of sheet metal construction.

Proper maintenance is important to achieve optimum performance from the system. The ability to properly perform maintenance on this equipment requires certain mechanical skills and tools. If you do not possess these skills, contact your dealer for maintenance. Consult your local dealer about the availability of maintenance contracts. Routine maintenance should include the following:

CAUTION:

The unit should never be operated without a filter in the return air system. Replace disposable filters with the same type and size.

- Inspect, clean or replace air filters at the beginning of each heating and cooling season, or more frequently if required.
- Inspect the condensate drain and outdoor coil at the beginning of each cooling season. Remove any debris. Clean the outdoor coil and louvers as necessary using a mild detergent and water. Rinse thoroughly with water.
- Inspect the electrical connections for tightness at the beginning of each heating and cooling season.
- The blower compartment should be cleaned monthly during the heating and cooling seasons to remove any dirt and lint that may have accumulated in the compartment or on the blower and motor. Buildup of dirt and lint on the blower and motor can create excessive loads on the motor resulting in higher than normal operating temperatures and possible shortened service life.
- Maintain heat exchanger and burners. The unit should operate for many years without excessive scale buildup in the heat exchanger, however, the heat exchanger, the vent system, and the burners should be inspected and cleaned (if required) by a qualified serviceman annually to ensure continued safe operation. Particular attention must be given to identify deterioration from corrosion or other sources.
- The motors for the circulating air blower, outdoor fan, and combustion blower are pre-lubricated at the factory. No further oiling is required for the life of this product.
- Inspect and clean the screen of the vent cover assembly at the beginning of each heating and cooling season.

Cleaning of Heat Exchanger

WARNING:

Holes in the heat exchanger can cause products of combustion to enter the home. Replace the heat exchanger if leaks are found. Failure to prevent products of combustion from being circulated into the living space can create potentially hazardous conditions including carbon monoxide poisoning that could result in personal injury or death.

If the heat exchanger must be cleaned due to soot or scale build up, follow the steps below.

1. Shut off the gas supply to the unit at the meter or at the manual valve in the gas supply piping.
2. Turn off all power to the unit and set the thermostat to the lowest temperature setting.
3. Remove the louvered access panel from the unit.
4. Turn the gas control knob (gas valve) to the OFF position. See [Figure 11 \(page 30\)](#) for gas valve shut off instructions.
5. Disconnect the wires from the gas valve, ignitor, flame sensor, combustion air motor, flame roll-out control, over-temperature limit switch, and pressure switch.
6. Remove the silicone rubber tube from the collector pan to the pressure switch.
7. Remove 4 nuts securing the combustion blower to the collector pan. Remove the combustion blower.
8. Remove all screws securing the collector pan to the unit. Remove the collector pan from the unit.

CAUTION:

To prevent damage to the unit or internal components, it is recommended that two wrenches be used when loosening or tightening nuts. Do not over tighten!

9. Using 2 wrenches, separate the ground-joint union in the gas supply piping at the unit.
10. Remove the piping between the gas valve and the ground-joint union, if necessary.
11. Carefully remove the four screws inside the burner box (2 at each end), securing the complete burner box assembly to the heat exchanger panel as shown in [Figure 8 \(page 22\)](#). **BE EXTREMELY CAREFUL NOT TO DAMAGE THE IGNITOR WHILE REMOVING THE BURNER ASSEMBLY.**

NOTE: The burner box may have hooks near the top on both ends. To remove this type of burner box, lift the burner box upwards and then remove the box from the unit.

12. Remove the screw securing the NOx baffle retainer clip to the heat exchanger panel, then pull the baffle straight forward to remove. Repeat these steps for each additional tube assembly. Keep components for reuse after cleaning.
13. Attach a round wire brush to a length of high grade stainless steel cable, such as drain clean-out cable. Attach the other end of the spring cable to a variable speed reversible drill. Slowly insert and rotate the cable into the top portion of the heat exchanger. Operate the drill alternating between forward and reverse, working the cable in and out several times to obtain sufficient cleaning. Repeat this process at each exchanger tube.
14. Remove all loosened debris from the heat exchanger tubes using high pressure air and vacuum cleaner.
15. Using a light, check the condition of the upper and lower sections of the heat exchanger tube.
16. Inspect the burners and if necessary, clean them carefully with a soft wire brush and/or the nozzle of a vacuum cleaner. **DO NOT DAMAGE THE IGNITOR OR FLAME SENSOR WHILE CLEANING THE BURNER.**
17. Reinstall the burner box assembly using the four screws removed in Step 13.
18. Reconnect the wires to the flame roll-out switch, flame sensor, and ignitor removed earlier in step 13.
19. Reinstall the collector box and combustion motor removed earlier in steps 7 & 8. Make sure the collector pan gasket seals the perimeter of the collector box when attaching it to the heat exchanger mounting panel and the combustion motor housing gasket is correctly positioned when reattaching the 4 nuts.
20. Reconnect the gas piping to the gas valve inlet.
21. Reconnect the wires to the gas valve terminals.
22. After re-installing the gas valve/manifold assembly, inspect the alignment of the burners with the heat exchanger tubes. The center of the burners should be aligned with the center of the tubes.
23. Follow the operating instructions found on the right side of the door and in the User's Manual to return the unit to operation.

Cleaning of Burners

If the burners require cleaning, follow the steps below.

1. Shut off the gas supply to the unit either at the meter or at a manual valve in the supply piping.
2. Turn off all power to the unit and set the thermostat to the lowest temperature setting.
3. Remove the louvered control access panel from the unit.
4. Turn the gas control knob to the OFF position. See [Figure 11 \(page 30\)](#) for gas valve shut off instructions.
5. Disconnect the wires from the gas valve, ignitor, and flame sensor.

CAUTION:

To prevent damage to the unit or internal components, it is recommended that two wrenches be used when loosening or tightening nuts. Do not over tighten!

6. Using two wrenches, separate the ground-joint union in the gas supply piping at the unit.
7. Remove the piping between the gas valve and the ground-joint union (if applicable).
8. Carefully remove the four screws inside the burner box (2 at each end), securing the complete burner box assembly to the heat exchanger panel as shown in [Figure 8 \(page 22\)](#). **BE EXTREMELY CAREFUL NOT TO DAMAGE THE IGNITOR WHILE REMOVING THE BURNER ASSEMBLY.**

NOTE: The burner box may have hooks near the top on both ends. To remove this type of burner box, lift the burner box upwards and then remove the box from the unit.

9. Inspect the burners for accumulated dust or debris. If necessary carefully clean them with a soft wire brush and a vacuum cleaner. **DO NOT DAMAGE THE IGNITER WHILE CLEANING THE BURNER.**
10. Reinstall the burner box assembly using the 4 screws removed in Step 13.
11. Reconnect the wires to the flame roll-out switch, flame sensor, and ignitor removed earlier in step 13.
12. Reinstall the gas manifold assembly to the burner assembly with the 4 screws, that were removed earlier in step 8. **NOTE:** It is important that the center of the orifices are aligned with the center of the burners.
13. Reconnect the gas piping to the gas valve inlet.
14. Reconnect the wires to the gas valve terminals.
15. After re-installing the gas valve/manifold assembly, inspect the alignment of the burners with the heat exchanger tubes. The center of the burners should be aligned with the center of the tubes.
16. Follow the operating instructions found on the right side of the door and in the User's Manual to return the unit to operation.

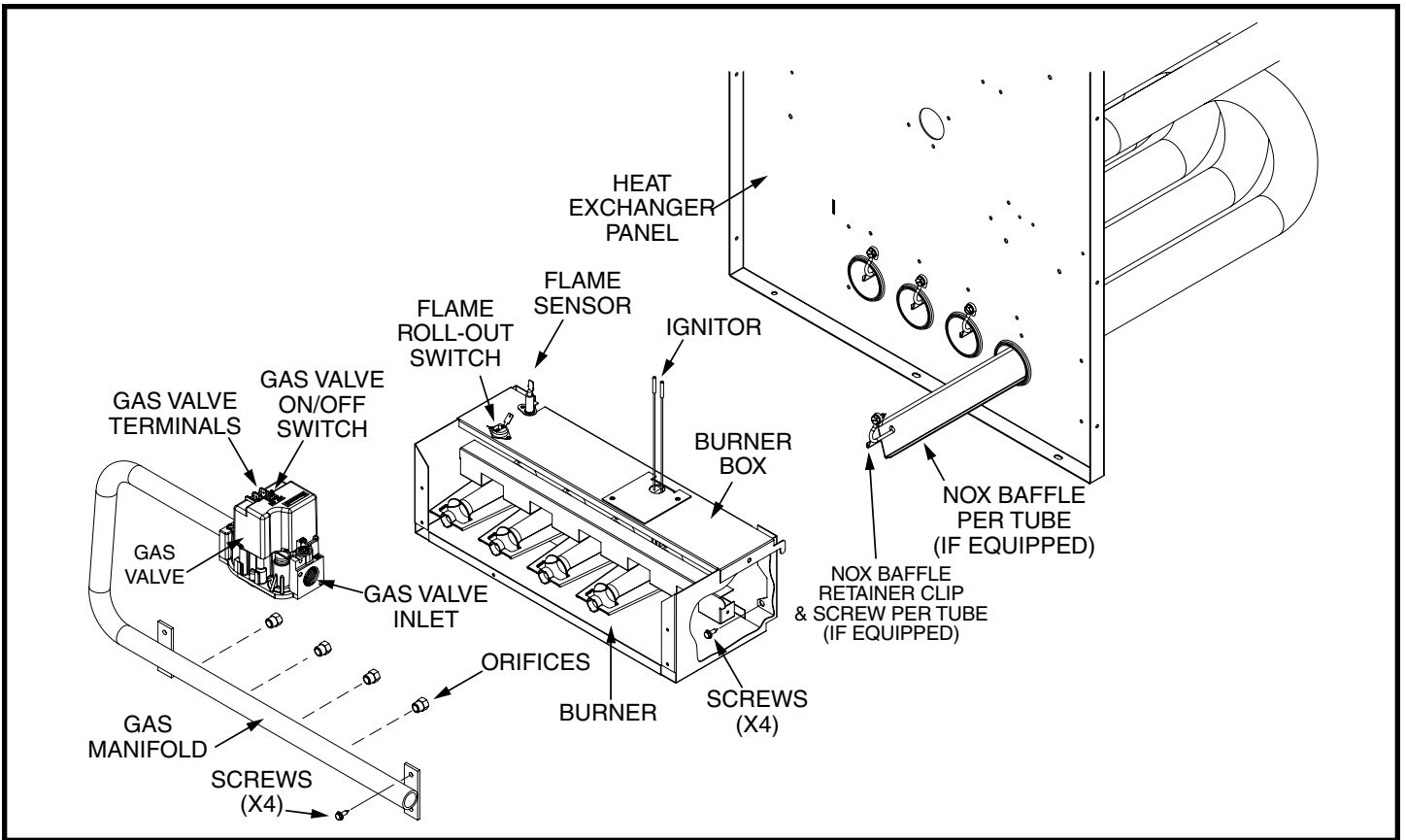

Figure 8. Burner & Manifold Assembly

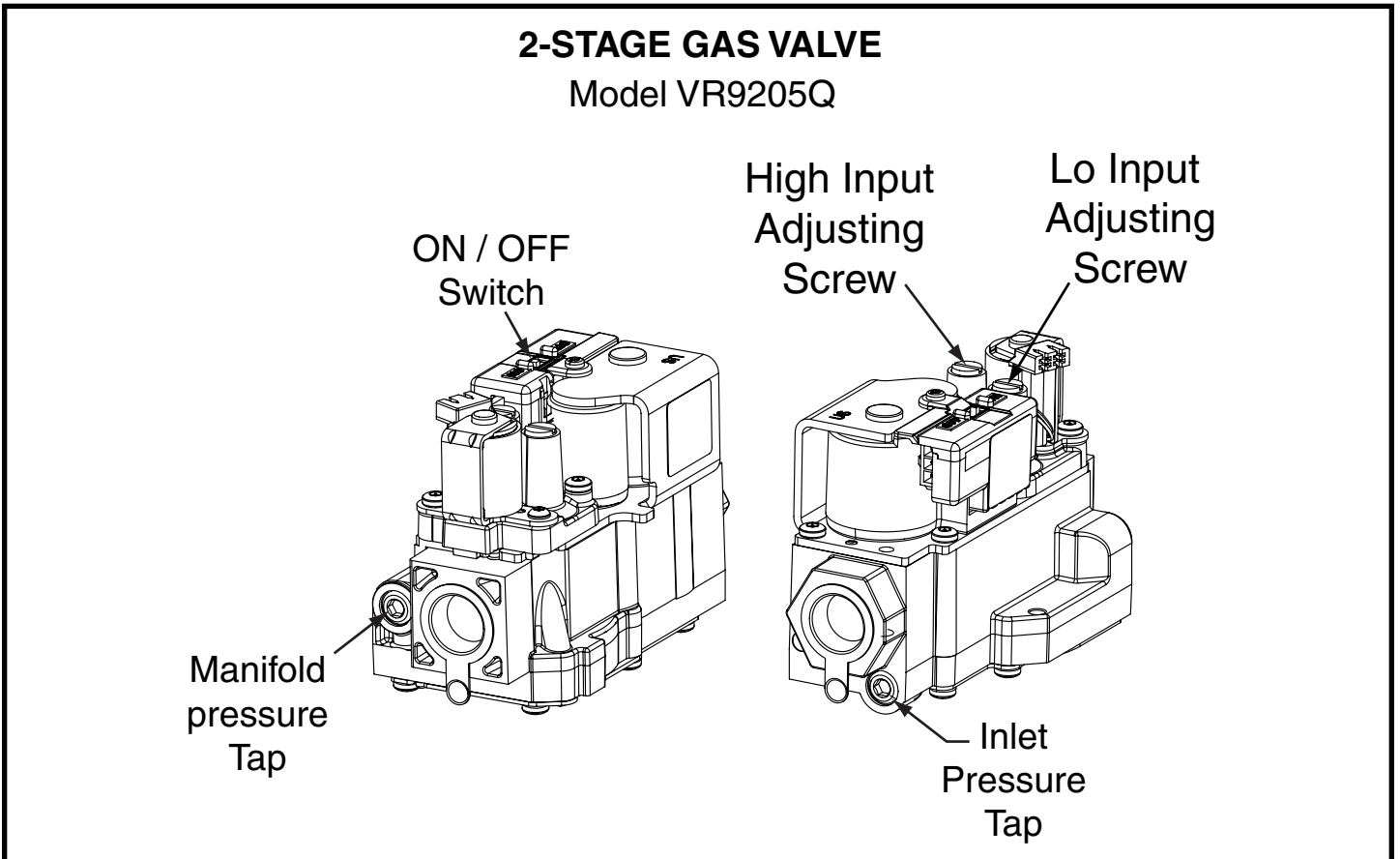

Figure 9. HI & LO Input Adjusting Screws

TROUBLESHOOTING - COOLING MODE

Diagnostic Display

The interface board located inside the control panel has a two character display which provides information regarding operational status and fault history. See [Figure 14 \(page 32\)](#). When 24VAC control power is provided to the board, the display will show some combination of characters. In order to diagnose a problem with the unit, or to determine its operational status, remove the control panel cover, then observe the 2-character lighted display on the interface board.

When control power is first applied to the control board with software versions 4.0 or later, the 2-character display will show the following three items in sequence, twice:

- Unit size (tons): 2½, 3½, 4½, or 5½
- Unit type: r6 for R6GI
- Software version, e.g. 4.0

This power-up display sequence is intended to confirm the correct programming of the inverter control board.

After power-up the display will alternate between an operating code as shown in [Table 18, \(page 32\)](#) and a list of diagnostic code(s) ([Table 7](#)) for up to the last 10 different faults or warnings. When this list is being displayed, each fault or warning code in memory will be displayed for 5 seconds. The most recent code will be the first one appearing in the series of codes displayed.

If there is a fault that is “active” when the display is viewed, the decimal point to the right of the right side character will be lit. The code for the most recent active fault will flash three times before the remainder of the fault history list is shown.

Fault codes are retained through loss of power. Any fault which has been in the list for more than 7 days (with control power applied) will be removed. When there are no active faults, the list of past fault codes can be cleared by shorting the TEST pins (J4, at the lower right side of the inverter control board) when the unit is powered up but not running.

NOTE: This action may also have other consequences - See Short Cycle Timer Override section below.

The 2-character LED display on the inverter control board is intended to be helpful in diagnosing problems. Under normal operation, the display will always show both a status indicator ([Table 18, \(page 32\)](#)) along with fault indications ([Table 7](#)).

The fault indications are a sequential listing of fault history. The last 10 fault codes recorded are displayed in sequence, with the most recent first. If there is an “active” fault, one which is currently detected and responsible for interrupting operation, the right hand decimal point in the display will be lit, and the first number in the list will double-blink at first, then appear again. If this decimal point is not lit, all codes listed are historical only, and none are “active”. Also, if no code numbers are displayed, there have been no faults recorded, or the history has been cleared.

NOTE: As standard practice, write down the fault codes in the history before attempting to clear the history. While troubleshooting, focus on fault codes that return as “active” after the history has been cleared. Do not replace hardware based on history alone, i.e., on faults that are not “active”.

DISPLAY CODE	FAULT INDICATIONS
01	Inverter Power Module Overcurrent
02	General Inverter Drive Fault
03	High Compressor Current
04	Current Sampling Error (Inverter)
05	High Inverter Heat Sink Temperature
06	High DC Bus Voltage (Inverter)
07	Low DC Bus Voltage (Inverter)
08	Low Line Voltage at Inverter
09	Line Overcurrent at Inverter
10	Line Voltage Sampling Error (Inverter)
11	Loss of Communication (Inverter Internal)
12	Inverter Heat Sink Sensor Failure
13	Loss of Communication (Inverter Internal)
14	Loss of Communication (IFB to Inverter)
15	Override, High Compressor Current
16	Override, High Line Current
17	Override, High Inverter Heat Sink Temp
18	Outdoor Fan Motor Fault
19	Low Pressure Switch Open
20	High Compressor Discharge Temperature
21	Interface Board Software Error
22	Sensor Failure - Suction Line Temperature
23	Sensor Failure - Compressor Discharge Temperature
24	Sensor Failure - Ambient Temperature
25	Sensor Failure - Coil Temp #2
26	Sensor Failure - Suction Pressure Transducer
27	Blower Motor Fault
28	Blower Communication Fault
29	Cooling Low Ambient Lockout

Table 7. Interface Board Fault Codes

WARNING:

Do not touch inverter conductors or the tops of its large capacitors until power has been off for at least 30 seconds. The inverter will retain a high voltage for a time after power has been removed. Failure to comply with this warning could result in serious injury, death or property damage.

The list of past faults can be cleared by shorting the TEST pins (J4) at the lower right side of the inverter control board (when the unit is powered up but not running). This procedure will also force the unit to bypass the normal 5 minute stop-to-start delay.

Fault and warning codes are listed in [Table 7](#) and on a label affixed to the inside surface of the control panel cover.

Short Cycle Timer Override

When performing startup tests in cooling or troubleshooting, the 5 minutes startup delay can be skipped by shorting the two J4 Test pins indicated in [Figure 14](#) for about 1 second while the compressor is off and waiting to start. **NOTE:** Use this feature carefully because it will also clear the fault codes stored in memory, which can make troubleshooting more difficult.

FUNCTION	TYPE	CONNECTION
High Pressure Switch	Opens 650 ±15 psig, recloses 460 ±15 psig	See Figure 8 & Figure 9
Low Pressure Switch	Opens 20 ±5 psig, recloses 35 ±5 psig	IFB* LP1-LP2
Ambient Air Temp	Thermistor 10KΩ @ 25° C (Fig. 10)	IFB* "OUTDOORTEMP" (BLK)
Compressor Discharge Temp	Thermistor 10KΩ @ 25° C (Fig. 10)	IFB* "DISCHARGE TEMP" (RED)
Coil Saturation Temp	Thermistor 10KΩ @ 25° C (Fig. 10)	IFB* "COIL #2 TEMP" (YEL)
Suction Temp	Thermistor 10KΩ @ 25° C (Fig. 10)	IFB* "SUCTION TEMP" (BLU)

*IFB=Interface Board

Table 8. Instrumentation List

Instrumentation

The 20 SEER iQ Drive split air conditioner includes instrumentation as listed in [Table 8](#). All items listed are connected to the interface board except for the high pressure switch. Refer to [Figure 12 \(page 31\)](#) & [Figure 13 \(page 31\)](#), [Figure 14 \(page 32\)](#), [Figure 15 \(page 33\)](#), [Figure 17 \(page 35\)](#) & [Figure 18 \(page 36\)](#). The five temperature sensors are color coded so that the color of the wire insulation matches the color of the connector base on the left side of the circuit board. All temperature sensors are 10k ohm thermistors. The resistances of these sensors (when disconnected from the interface board) may be checked against [Figure 23 \(page 40\)](#) for troubleshooting purposes. The charts show the thermistor resistance-temperature curve broken into two parts for ease of use.

Inverter Circuit Board LEDs

For some inverter-related fault codes, it is helpful to note at least whether or not LEDs are lit on the main inverter circuit boards, which are mounted behind the interface board on which the codes are displayed. For 2, 3, and 4-ton models, look for a lit LED about 3 inches directly behind the 2-character display. For the 5-ton model look for a lit LED about 3 inches directly behind the lower edge of the secondary contactor that is mounted on the left side of the upper mounting bracket.

NOTE: There are other LEDs on the inverter circuit boards as well as those described above.

For normal operation the inverter LEDs located as described above will blink green slowly. When there is an inverter-generated fault, a red LED next to the green one will flash. Normally this will be translated into a 2-digit fault code on the main display.

If the green LED (described above) is not lit, it generally indicates that line voltage is not getting to the inverter via the contactor. Check for the presence of 208/230 volts between the top two terminals of the main contactor. If voltage is present, the inverter needs to be replaced, or internal wiring is incorrect. If line voltage is absent, check for 24 vac across the main contactor coil, and verify line voltage between the lower terminals of the contactor. If 24 volt coil voltage is absent, check continuity through the high pressure switch, and verify that the COMMUNICATIONS PORT plug is in place at J6 at the bottom edge right of the interface board. If line voltage is absent at the lower terminals of the contactor, check power wiring back to the unit's line power input terminals.

No Control Board Display

If the 2-character display on the interface board shows nothing, verify that 24 vac control voltage is present between **R** & **C** (red and black wires of the field wiring harness plugged into the right side of the control board). If voltage is absent, check wiring back to the transformer. If voltage is present but the display is blank, the control board needs to be replaced. Check wiring for indications of a direct short before trying a new board.

Troubleshooting Individual Fault Codes (when active)

Follow the recommended troubleshooting procedures in [Table 9](#) for "active" faults. In some cases more than one fault code or different active codes may be generated by one issue, e.g. interruption of line power. Always cycle line power (30 seconds off, then on for at least 1 minute) to confirm that an active fault returns, is re-declared, before considering replacing hardware. Most inverter-related faults are at least temporarily cleared by cycling power in this manner. Do not replace hardware based on history alone, on faults that are not "active".

CODES	DESCRIPTION
01 03 05 09	These codes indicate abnormal high current or high inverter temperature. If they persist and return as active fault codes, they may indicate a faulty inverter drive or a wrong interface board/inverter combination.
02	Compressor Drive Failure – This generally indicates a compressor problem which may be temporary or permanent. If the compressor has just been replaced, recheck the U, V, and W compressor leads for a connection mistake. Before the inverter declares this fault during an attempted startup, it will try to start the compressor 4 times, with approximately 20 seconds pause between attempts. During start attempts, listen for compressor noise; if none, the compressor may need to be replaced. Check compressor phase-to-phase resistances; they should all be less than 1.5 ohms and within 0.2 Ω of each other. If compressor noise is loud, squealing, or otherwise unusual, the compressor may need to be replaced. If the compressor restarts normally, this fault code may be simply an indication that the compressor speed has been temporarily disrupted by either starting or shutting down abruptly against a high pressure ratio. In either case, the system may be normal but only temporarily affected by abnormal running conditions.
04 10 11 12 13	These fault codes refer to internal inverter operation and are likely to indicate inverter failure. If they persist and return as active fault codes, replace the inverter assembly.
06	High DC Bus Voltage – This is an indication that line voltage exceeded 10% over nominal value. The cause is likely to be power grid abnormalities or a poorly controlled generator.
07	Low DC Bus Voltage – In most cases this is an indication that 208/230 volt line power was interrupted or disconnected. It may also indicate low line voltage or, rarely, an internal inverter failure.
08	Low AC Line Voltage – This indicates that line voltage has dropped below approximately 170 volts. It may also indicate loss of line power, in which case Code 07 may appear in addition to or instead of this code.
14	Loss of Communication Between Inverter and Interface Board – Check the inverter LEDs (as described in Inverter Circuit Board LEDs section) for an indication that the inverter has line power. Follow the troubleshooting steps described in that section first. If the inverter LEDs are lit but the code is active, verify that the 4-pin plug at J5 (INVERTER PORT) is connected at the bottom edge center of the interface board. If these checks do not resolve the fault and the fault remains active, replace the interface board.
15 16 17	These are warning codes that simply indicate that a high current or temperature condition was reached, and that the inverter was able to keep the parameter in an acceptable range by automatically reducing speed. These conditions do not result in the unit shutting down (unless the current or temperature increased further and reached a shutdown limit, in which case another code would be displayed). NOTE: If a high current or temperature shutdown occurs, these warning codes are not necessarily displayed and stored.
18	Outdoor Fan Fault – Check that 208/230 vac line power is being provided through the main contactor to the fan. In 5-ton models this is through a terminal block located to the right of the contactor. If ok, check that the 2-wire fan power harness (brown and black wires) is connected as indicated on the wiring diagram. If ok, check that the fan control harness is properly connected at J15 (PWM FAN CONTROL) at the top edge, center, of the control board. If ok, check the small square white label on the interface board which has two numbers printed along its edges. Examine the date code number, the one that does not begin with “1AC3”. If this other number begins with “1235” or lower, replace the interface board. If this date code starts with “1245” or higher, and the other checks do not reveal the source of the problem, replace the fan motor.
19	Low Pressure Switch Open – A low pressure condition (less than 20 psig (± 5)) must exist in the suction line for more than 4 minutes to trigger this fault. A pressure of 35 psig (± 5) is required to reclose the switch. Check liquid line temperature and pressure against the charging chart to confirm that charge level is not significantly low. Compare gage measurement against the 20 psi switch limit (with the system running). If gage measurements are good, check that the pressure switch is depressing the Schrader pin. Verify that the blue wires from the switch are properly connected to the LOW PRESSURE SWITCH terminals at the lower edge, left of center, on the interface board. If the system is normal, an active low pressure switch fault should clear when the compressor is off. Check continuity across the wire terminals. If the connection is electrically open, and manual pressure checks show that system pressure is good while running but the fault remains active, replace the switch.
20	High Compressor Discharge Temperature – If compressor discharge line temperature exceeds 221° F, this fault is triggered. Check for conditions that would cause high discharge temperature and pressure, e.g. fouled or blocked coil, overcharge. See also fault code 23.
21	Interface Board Software Corruption – This code indicates that the interface board needs to be replaced. It should never be encountered.
23	Compressor Discharge Temp Sensor Failure – This fault code indicates an open or shorted sensor. See also fault code 20.
24	Ambient Temp Sensor Failure – This fault code indicates an open or shorted sensor. Look for a pinched wire with cut insulation (sensor wire insulation is black).
29	Cooling Low Temperature Lockout – This is an informational code that indicates that the unit attempted to start or run in cooling mode when outdoor ambient temperature was below 50° F, which is not permitted. If such a lockout occurs, the unit will restart when ambient temperature exceeds 55° F. If the ambient temperature sensor fails open or is disconnected, this code will also appear.

Table 9. Individual Fault Codes

HEATING COMPONENT FUNCTIONS

Flame Roll-Out Control - The flame roll-out control acts to verify that the burner flame is being drawn into the heat exchanger tubes. If the burner flame is not being drawn into the heat exchanger tubes, the roll-out control will open within several seconds and the integrated control diagnostic light will flash one time. The circulating air blower will continue to operate while the flame roll-out control is open. See [Figure 16 \(page 34\)](#).

Flame Sensor - The flame sensor acts to prove that flame has carried over from the ignitor to the left-most burner. If no flame is sensed, the unit will be shut down automatically.

Dual Pressure Switch - The dual pressure switch verifies that the inducer motor is drawing the combustion gases through the heat exchanger tubes and venting the gases through the vent system for both high and low fire conditions.

Gas Valve - The gas valve controls the flow of gas to the burners in both low and high fire. When the gas valve is energized it automatically opens and regulates the gas pressure in the manifold.

Over-Temperature Limit Control - The over-temperature limit control prevents the air temperature leaving the unit from exceeding the maximum outlet air temperature. If the limit opens, the integrated control diagnostic will flash one time. The circulating air blower will continue to operate while the over-temperature limit control is open.

OPTIONAL FURNACE CONTROL BOARD CONNECTIONS

Electronic Air Cleaner - The furnace control board provides output terminals for an optional electronic air cleaner (EAC) that can be installed in the return air duct of your system. THE EAC output is energized any time the HEAT or COOL blower speed is energized. Control ratings are 1.0 Amp. @ 240 VAC. Output connections are made via board terminals labeled EAC and NEUTRAL.

Humidifier - The furnace control board provides output terminals for an optional humidifier (HUM) that can be installed on your system. The HUM output is energized any time the furnace inducer motor is energized. Control ratings are 1.0 Amp. @ 240 VAC. Output connections are made via board terminals labeled HUM and NEUTRAL.

TROUBLESHOOTING - HEATING MODE

If the furnace fails to operate check the following:

- Is the thermostat operating properly?
- Are the blower compartment door(s) in place?
- Is the furnace disconnect closed?
- Has the circuit breaker tripped or the control board fuse burned open?
- Is the gas turned on?
- Are any manual reset switches open?
- Is the filter dirty or plugged?
- Is the flame sensor coated? (Remove and clean with steel wool. **Do not use emery cloth or sandpaper!**)
- Are all the LED's on the furnace and motor control boards constantly ON? If not, refer to [Table 10](#) & [Table 11](#) to determine fault condition.

IMPORTANT NOTE:

The furnace will lock out after 5 failed attempts for ignition and will try again every hour if the call for heat remains.

DIAGNOSTIC DESCRIPTION	GREEN LED	RED LED
Control Fault (No Power)	Off	Off
L1/Neutral Polarity Fault	Flash	Flash
1 Hour Lockout	Alternating Flash	
Normal Operation	On	On
Pressure Switch Closed Fault	On	Flash
Pressure Switch Open Fault	Flash	On
Open Limit Switch Fault	Flash	Off
Motor Fault	On	Off
DIAGNOSTIC DESCRIPTION	YELLOW LED	
Low Flame Sensor Signal	Continuous Flash	
Flame Present	On	

Table 10. Furnace Control Board Fault Conditions

	DIAGNOSTIC DESCRIPTION	GREEN LED	RED LED
VARIABLE SPEED FURNACES	Control Fault (No Power)	Off	Off
	Normal Operation	On	On
	Motor Fault	On	Flash
	Communications Fault	Flash	Flash

Table 11. Motor Control Board Fault Conditions

REPLACEMENT PARTS

Replacement parts are available through all Nordyne distributors. Please have the complete model and serial number of the unit when ordering replacement parts.

ELECTRICAL:

- Blower Control Boards
- Compressors
- Contactors
- Gas Valves
- Ignition Control Boards
- Ignitors/Flame Sensors
- Inverters
- Pressure Switches
- Reactor
- Relays
- Temperature Limit Switches
- Thermistors
- Thermostats
- Transformers

MOTORS:

- Blower Motor
- Fan Motor
- Inducer Blower Motor

COMPONENTS:

- Blower Assembly
- Burner Manifold
- Burners/Orifices
- Cabinet Panels
- Coil
- Electronic Expansion Valves
- Fan Grille
- Filter/Driers
- Gaskets
- Heat Exchanger

FIGURES & TABLES

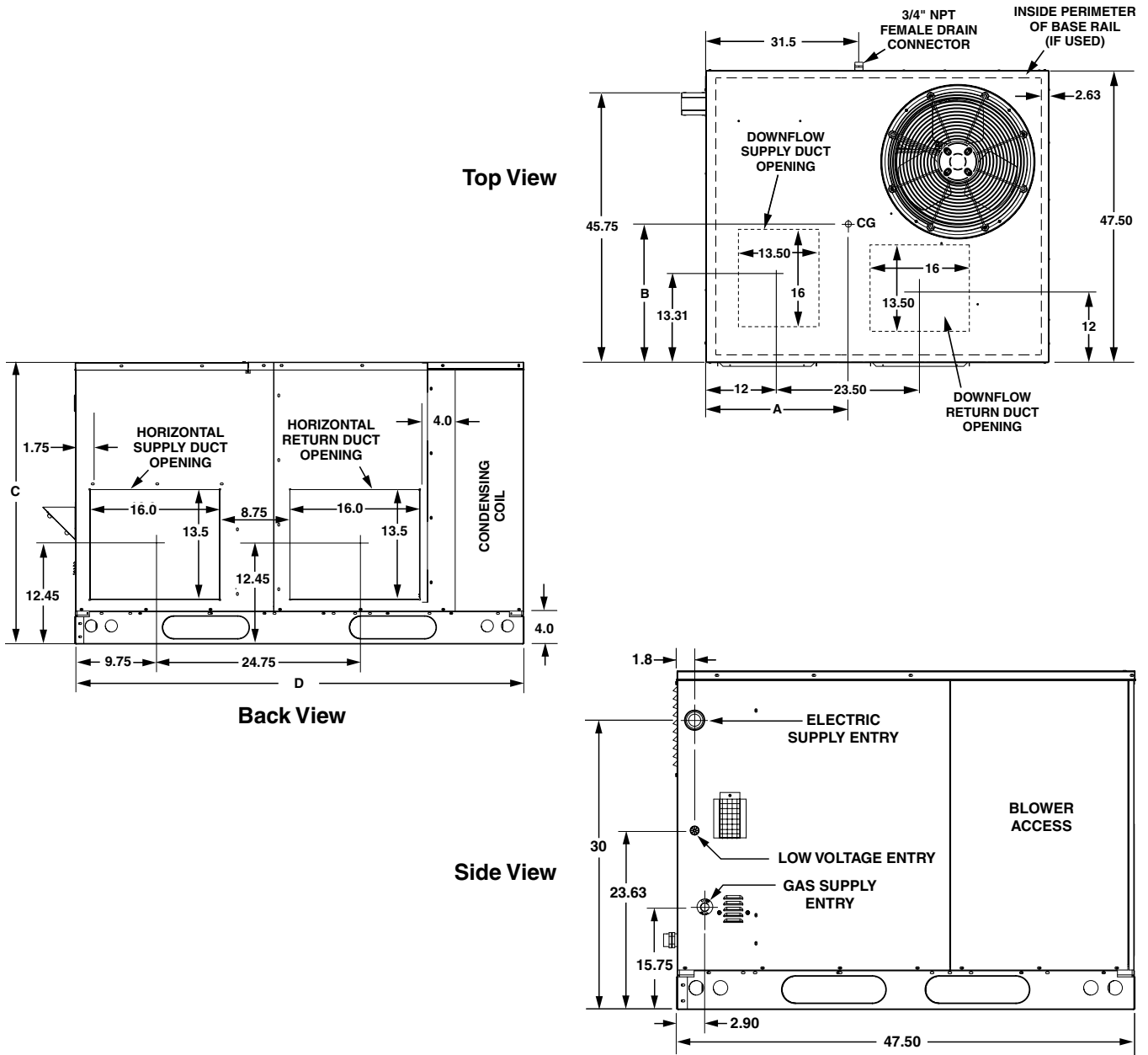

Figure 10. Unit Dimensions

MODEL NUMBER	UNIT WEIGHT (LB)	CENTER OF GRAVITY		-C- (HEIGHT IN INCHES)		-D-
		-A-	-B-	-C- (HEIGHT IN INCHES)		
				WITH BASE RAILS	WITHOUT BASE RAILS	
E24K080X	437	26.0	27.0	39.0	35.3	55.8
E36K100X	457	26.0	27.0	39.0	35.3	55.8
E48K120X	530	27.0	26.5	47.0	43.3	55.8
E60K120X	630	30.0	26.5	47.0	43.3	63.6*

NOTE: Unit weights shown are with the unit unpacked. Dimensions shown in inches (mm).

*Extended base pan models use same roof curb as 2 - 4 ton units.

Table 12. Center of Gravity & Shipping Weights

Airflow Data

MODEL NUMBER	HEATING INPUT (BTUH)	HEATING OUTPUT (BTUH)	HEATING RANGE	HEATING RISE RANGE (°F)	BLOWER SIZE	MOTOR (HP)
E24K080X	80,000	64,800	1025 - 1375	35-65	11 X 8	1/2
	52,000	42,100	800 - 1050			
E36K100X	100,000	81,000	1150 - 1500	40-70	11 X 8	1/2
	65,000	52,650	875 - 1200			
E48K120X	120,000	97,200	1550 - 2000	40-70	11 X 10	1
	78,000	63,180	1200 - 1575			
E60K120X	120,000	97,200	1550 - 2000	40-70	11 X 10	1
	78,000	63,180	1200 - 1575			

NOTE: CFM and Rise are independent of ESP in a variable speed blower.

Table 13. Nominal Heating Airflow Rates & Temperature Rises (° F)

2 TON CFM SETTINGS					3 TON CFM SETTINGS					4 TON CFM SETTINGS					5 TON CFM SETTINGS									
COOLING BLOWER SELECTOR SETTING					RECOMMENDED AIRFLOW (HIGH CFM)	COOLING BLOWER SELECTOR SETTING					RECOMMENDED AIRFLOW (HIGH CFM)	COOLING BLOWER SELECTOR SETTING					RECOMMENDED AIRFLOW (HIGH CFM)							
(1)	5	6	7	8		(1)	5	6	7	8		(1)	5	6	7	8		(1)	5	6	7	8		
0	0	0	0	0	650	1	0	0	0	0	900	0	0	0	0	0	1375	1	0	0	0	0	1500	
0	0	0	0	1	680	1	0	0	0	1	935	0	0	0	0	1	1400	1	0	0	0	1	1540	
0	0	0	1	0	710	1	0	0	1	0	970	0	0	0	1	0	1425	1	0	0	1	0	1580	
0	0	0	1	1	740	1	0	0	1	1	1005	0	0	0	1	1	4 TON	1450	1	0	0	1	1	1620
0	0	1	0	0	770	1	0	1	0	0	1040	0	0	1	0	0	1475	1	0	1	0	0	5 TON	1660
0	0	1	0	1	800	1	0	1	0	1	1075	0	0	1	0	1	1500	1	0	1	0	1	1700	
0	0	1	1	0	830	1	0	1	1	0	1110	0	0	1	1	0	1525	1	0	1	1	0	1740	
0	0	1	1	1	860	1	0	1	1	1	1145	0	0	1	1	1	1550	1	0	1	1	1	1780	
0	1	0	0	0	890	1	1	0	0	0	3 TON	1180	0	1	0	0	0	1575	1	1	0	0	0	1820
0	1	0	0	1	920	1	1	0	0	1	1215	0	1	0	0	1	1600	1	1	0	0	1	1860	
0	1	0	1	0	950	1	1	0	1	0	1250	0	1	0	1	0	1625	1	1	0	1	0	1900	
0	1	0	1	1	980	1	1	0	1	1	1285	0	1	0	1	1	1650	1	1	0	1	1	1940	
0	1	1	0	0	1010	1	1	1	0	0	1320	0	1	1	0	0	1675	1	1	1	0	0	1980	
0	1	1	0	1	1040	1	1	1	0	1	1355	0	1	1	0	1	1700	1	1	1	0	1	2020	
0	1	1	1	0	1070	1	1	1	1	0	1390	0	1	1	1	0	1750	1	1	1	1	0	2060	
0	1	1	1	1	1100	1	1	1	1	1	1425	0	1	1	1	1	1800	1	1	1	1	1	2100	

NOTES: Dip switch positions - 0 = OFF 1 = ON

- Switch (1) selects blower program in conjunction with motor horsepower. 0 = 2 or 4 Ton, 1 = 3 or 5 Ton.
- Recommended CFM's (factory settings) are highlighted in **bold**.

Table 14. Airflow Settings for Cooling Mode

HEATING BLOWER SELECTOR SETTING	2 TON CFM SETTINGS				HEATING BLOWER SELECTOR SETTING	3 TON CFM SETTINGS				HEATING BLOWER SELECTOR SETTING	4 TON CFM SETTINGS				HEATING BLOWER SELECTOR SETTING	5 TON CFM SETTINGS															
	LOW HEAT		HIGH HEAT			LOW HEAT		HIGH HEAT			LOW HEAT		HIGH HEAT			LOW HEAT		HIGH HEAT													
	CFM	RISE	CFM	RISE		CFM	RISE	CFM	RISE		CFM	RISE	CFM	RISE		CFM	RISE	CFM	RISE												
(1)	2	3	4	64,800	80,000	(1)	2	3	4	81,000	100,000	(1)	2	3	4	97,200	120,000	(1)	2	3	4	97,200	120,000								
0	0	0	0	800	50	1025	59	1	0	0	0	875	56	1150	66	0	0	0	0	1200	54	1550	57	1	0	0	0	1200	54	1550	57
0	0	0	1	850	48	1075	57	1	0	0	1	925	53	1200	63	0	0	0	1	1250	50	1650	54	1	0	0	1	1250	50	1650	54
0	0	1	0	875	46	1125	55	1	0	1	0	975	50	1300	58	0	0	1	0	1300	47	1750	52	1	0	1	0	1300	47	1750	52
0	0	1	1	925	44	1175	53	1	0	1	1	1000	48	1350	56	0	0	1	1	1375	44	1800	50	1	0	1	1	1375	44	1800	50
0	1	0	0	950	42	1225	51	1	1	0	0	1050	46	1375	55	0	1	0	0	1450	42	1850	48	1	1	0	0	1450	42	1850	48
0	1	0	1	1000	40	1275	49	1	1	0	1	1100	44	1400	54	0	1	0	1	1475	40	1900	47	1	1	0	1	1475	40	1900	47
0	1	1	0	1025	39	1325	47	1	1	1	0	1150	42	1450	52	0	1	1	0	1525	39	1950	46	1	1	1	0	1525	39	1950	46
0	1	1	1	1050	38	1375	45	1	1	1	1	1200	41	1500	51	0	1	1	1	1575	38	2000	45	1	1	1	1	1575	38	2000	45

- Switch (1) selects blower program in conjunction with motor horsepower. 0 = 2 or 4 Ton, 1 = 3 or 5 Ton.
- Recommended CFM's (Factory settings) and temperature rises are highlighted in **bold**. Use of any other setting may result in nuisance trips.
- Temperature rises in tables are approximate. Actual temperature rises may vary.

Table 15. Airflow Settings (CFM) & Rise (° F) for Heating Mode

Gas Information

CAPACITY OF BLACK IRON GAS PIPE (CU. FT. PER HOUR) FOR NATURAL GAS (SPECIFIC GRAVITY - 0.60)								
NOMINAL PIPE DIAMETER (IN.)	LENGTH OF PIPE RUN (FEET)							
	10	20	30	40	50	60	70	80
1/2	130	90	75	65	55	50	45	40
3/4	280	190	150	130	115	105	95	90
1	520	350	285	245	215	195	180	170
1 1/4	1,050	730	590	500	440	400	370	350
1 1/2	1,600	1,100	890	760	670	610		

$\text{Cubic Feet Per Hour Required} = \frac{\text{Input To Furnace (Btu/hr)}}{\text{Heating Value of Gas (Btu/Cu. Ft.)}}$
--

NOTE: The cubic feet per hour listed in the table above must be greater than the cubic feet per hour of gas flow required by the furnace. To determine the cubic feet per hour of gas flow required by the furnace, divide the input rate of the furnace by the heating value (from gas supplier) of the gas.

Table 16. Gas Pipe Capacities

GAS FLOW RATES (CUBIC FEET PER HOUR)			
TIME FOR ONE REVOLUTION (SECONDS)	CUBIC FEET PER REVOLUTION OF GAS METER		
	1	5	10
10	360	1,800	3,600
12	300	1,500	3,000
14	257	1,286	2,571
16	225	1,125	2,250
18	200	1,000	2,000
20	180	900	1,800
22	164	818	1,636
24	150	750	1,500
26	138	692	1,385
28	129	643	1,286
30	120	600	1,200
32	113	563	1,125
34	106	529	1,059
36	100	500	1,000
38	95	474	947
40	90	450	900
42	86	429	857
44	82	409	818
46	78	391	783
48	75	375	750
50	72	360	720
52	69	346	692
54	67	333	667
56	64	321	643
58	62	310	621
60	60	300	600
62	58	290	581
64	56	281	563

GAS FLOW RATES (CUBIC FEET PER HOUR)			
TIME FOR ONE REVOLUTION (SECONDS)	CUBIC FEET PER REVOLUTION OF GAS METER		
	1	5	10
66	55	273	545
68	53	265	529
70	51	257	514
72	50	250	500
74	49	243	486
76	47	237	474
78	46	231	462
80	45	225	450
82	44	220	439
84	43	214	429
86	42	209	419
88	41	205	409
90	40	200	400
92	39	196	391
94	38	191	383
96	38	188	375
98	37	184	367
100	36	180	360
102	35	176	353
104	35	173	346
106	34	170	340
108	33	167	333
110	33	164	327
112	32	161	321
114	32	158	316
116	31	155	310
118	31	153	305
120	30	150	300

Table 17. Gas Flow Rates

FOR YOUR SAFETY READ BEFORE OPERATING

WARNING: If you do not follow these instructions exactly, a fire or explosion may result causing property damage, personal injury, or loss of life.

- A. This appliance does not have a pilot. It is equipped with an ignition device which automatically lights the burner. Do **not** try to light the burner by hand.
- B. BEFORE OPERATING smell all around the appliance area for gas. Be sure to smell next to the floor because some gas is heavier than air and will settle on the floor.
- WHAT TO DO IF YOU SMELL GAS
- Do not try to light any appliance.
 - Do not touch any electrical switch; do not use any phone in your building.
 - Immediately call your gas supplier from a neighbor's phone. Follow the gas supplier's instructions.
 - If you cannot reach your gas supplier, call the fire department.
- C. Use only your hand to push in or turn the gas control knob. Never use tools. If the knob will not push in or move by hand, do not try to repair it, call a qualified service technician. Force or attempted repair may result in a fire or explosion.
- D. Do not use this appliance if any part has been under water. Immediately call a qualified service technician to inspect the appliance and to replace any part of the control system and any gas control which has been under water.

POUR VOTRE SÉCURITÉ. À LIRE AVANT L'EMPLOI

ATTENTION! L'inobservation de ces instructions peut entraîner un incendie ou une explosion pouvant causer des dommages à votre propriété à votre personne, ou la mort.

- A. Cet appareil ménager n'a pas de veilleuse. Il est doté d'un système d'allumage automatique. Ne pas essayer d'allumer le brûleur manuellement.
- B. AVANT L'USAGE. Attention à une possible odeur de gaz surtout au niveau du plancher où les gaz les plus lourds ont la tendance de se concentrer.
- EN CAS D'ODEUR DE GAZ.
- Ne mettre en marche aucun appareil électrique.
 - Ne toucher à aucun commutateur électrique, ne pas employer le téléphone.
 - Quitter le bâtiment immédiatement et avvertir la compagnie du gaz en utilisant le téléphone d'un voisin.
 - A défaut de la compagnie du gaz, avvertir le service des pompiers.
- C. Enfoncer ou faire tourner le robinet à gaz à la main seulement. Ne jamais utiliser d'outils. S'il n'est pas possible de faire tourner ou d'enfoncer le robinet à la main, ne pas essayer de le réparer. Faire appel à un spécialiste. Forcer ou tenter de réparer le robinet pourrait être à l'origine d'une explosion ou d'un incendie.
- D. Il est déconseillé d'utiliser cet appareil en contact prolongé avec l'eau. Faire inspecter ou remplacer toute commande par un technicien qualifié si un des systèmes de contrôle du gaz s'est trouvé sous l'eau.

OPERATING INSTRUCTIONS

1. **STOP!** Read the safety information above on this label.
2. Set the thermostat to the lowest setting.
3. Turn off all electrical power to the appliance.
4. The appliance's ignition device automatically lights the burner. Do not try to light burner by hand.
5. Remove the control access door/panel (upper door if two-door model).
6. Move the gas control switch to the "OFF" position. (See Figure 1)
7. Wait five (5) minutes to clear out any gas. Then smell for gas, including near the floor. If you smell gas, **STOP!** Follow "B" in above information. If you don't smell gas, go to the next step.
8. Move the gas control switch to the "ON" position. (See Figure 1)
9. Replace the control access door/panel (upper door if two door model).
10. Turn on all electrical power to the appliance.
11. Turn the thermostat to a desired setting.
12. If the appliance will not operate, follow the instructions "To Turn Off Gas To Appliance" and call your service technician or gas supplier.

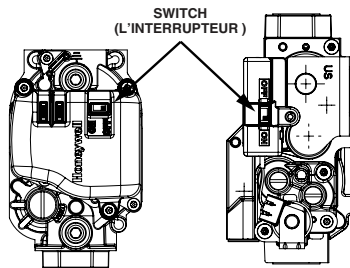

MODE D'EMPLOI

1. **ATTENTION!** Lire d'abord la liste des mesures de sécurité ci-dessus.
2. Mettre le thermostat à la position minimale.
3. Couper le courant électrique qui mène à l'appareil.
4. Cet appareil ménager étant doté d'un système d'allumage automatique, ne pas essayer d'allumer le brûleur manuellement.
5. Retirer le panneau/volet d'accès de commande (panneau supérieur s'il s'agit d'un modèle à deux panneaux).
6. Réglez l'interrupteur de commande du gaz à la position "OFF". (voir Figure 1).
7. Attendre cinq (5) minutes pour s'assurer de la dissipation du gaz. En cas d'odeur, ARRÊTER LE PROCÉDÉ. Suivre les instructions ci-dessus (Section B). En l'absence de toute odeur de gaz, avancer à l'étape suivante.
8. Réglez l'interrupteur de commande du gaz à la position "ON". (voir Figure 1).
9. Remettre le panneau/volet d'accès de commande en place (panneau supérieur s'il s'agit d'un modèle à deux panneaux).
10. Rebrancher l'appareil sur le réseau électrique.
11. Ajuster le thermostat à la position désirée.
12. Si l'appareil ne fonctionne pas, suivre les "Directives d'arrêt" cidessous et appeler le technicien de service.

TO TURN OFF GAS TO APPLIANCE

1. Set the thermostat to the lowest setting.
2. Turn off all electrical power to the appliance if service is to be performed.
3. Remove the control access door/panel (upper door if two-door model).
4. Move the gas control switch to the "OFF" position. Do not use force. (See Figure 1)
5. Replace the control access door/panel (upper door if two-door model).

DIRECTIVES D'ARRÊT

1. Mettre le thermostat à la position minimale.
2. Débrancher l'appareil en prévision de la réparation.
3. Retirer le panneau/volet d'accès de commande (panneau supérieur s'il s'agit d'un modèle à deux panneaux).
4. Réglez l'interrupteur de commande du gaz à la position "OFF". Ne forcez pas. (voir Figure 1).
5. Remettre le panneau/volet d'accès de commande en place (panneau supérieur s'il s'agit d'un modèle à deux panneaux).



10186330 (Replaces 7106740)
(10/17)

Figure 11. Gas Valve Label

Electrical Information

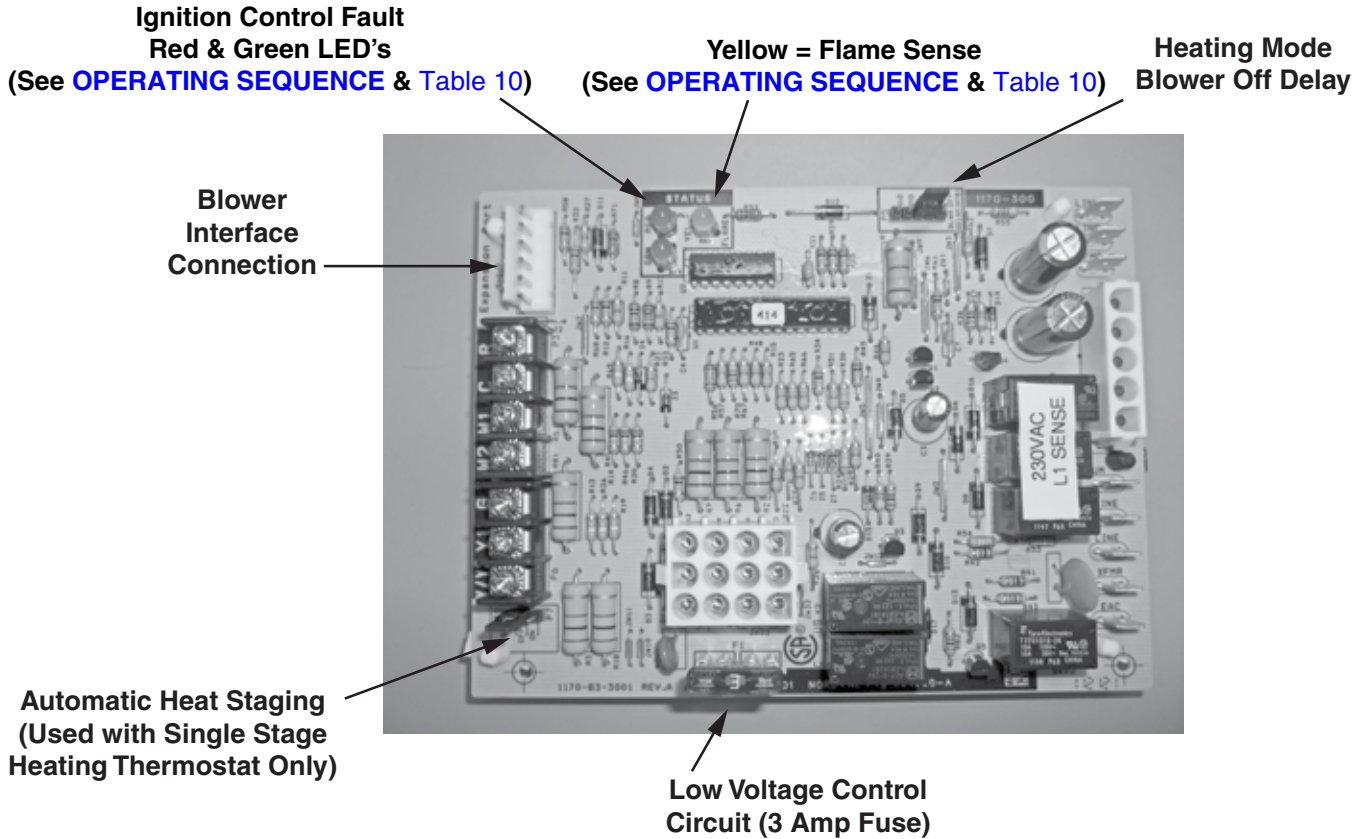

Figure 12. Two-Stage, Hot Surface Ignition & Blower Control Board

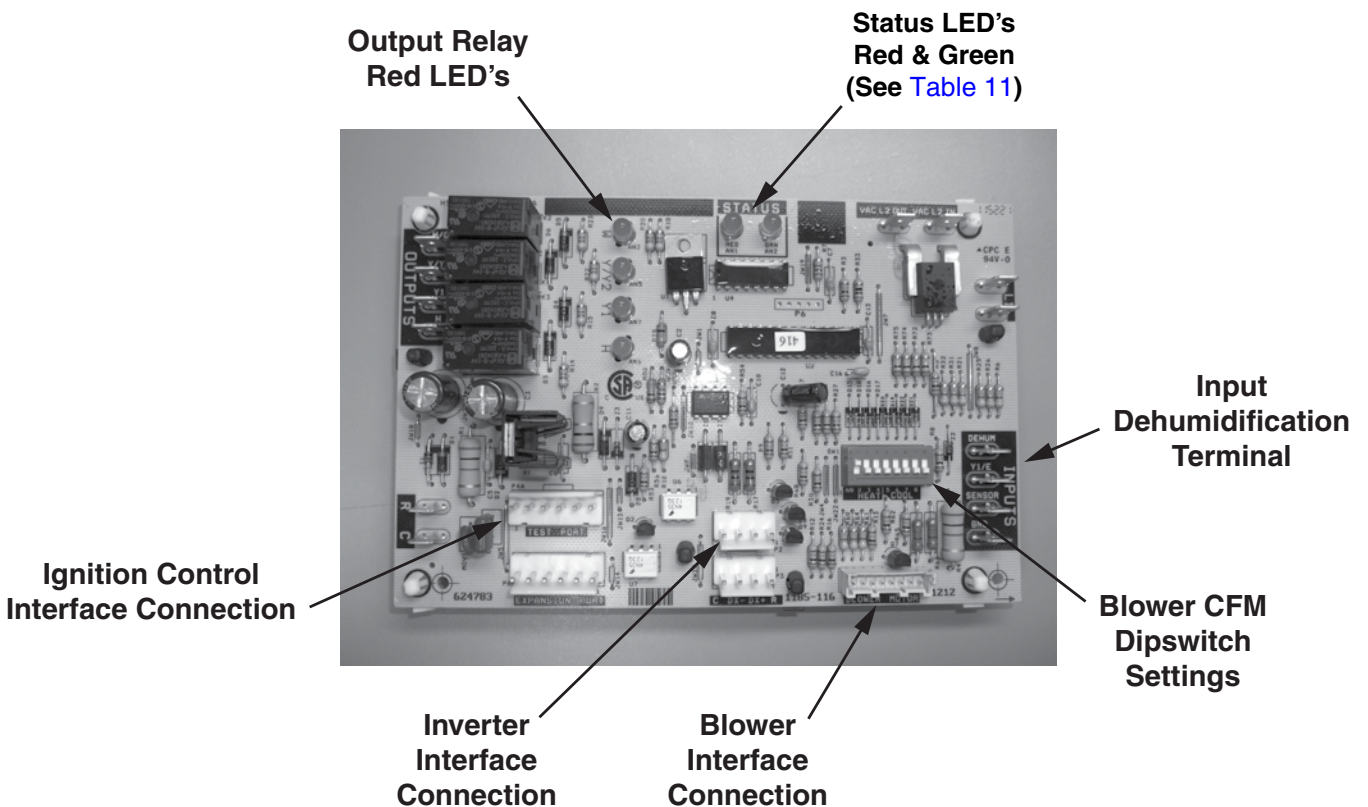

Figure 13. VSHE Blower Control Board

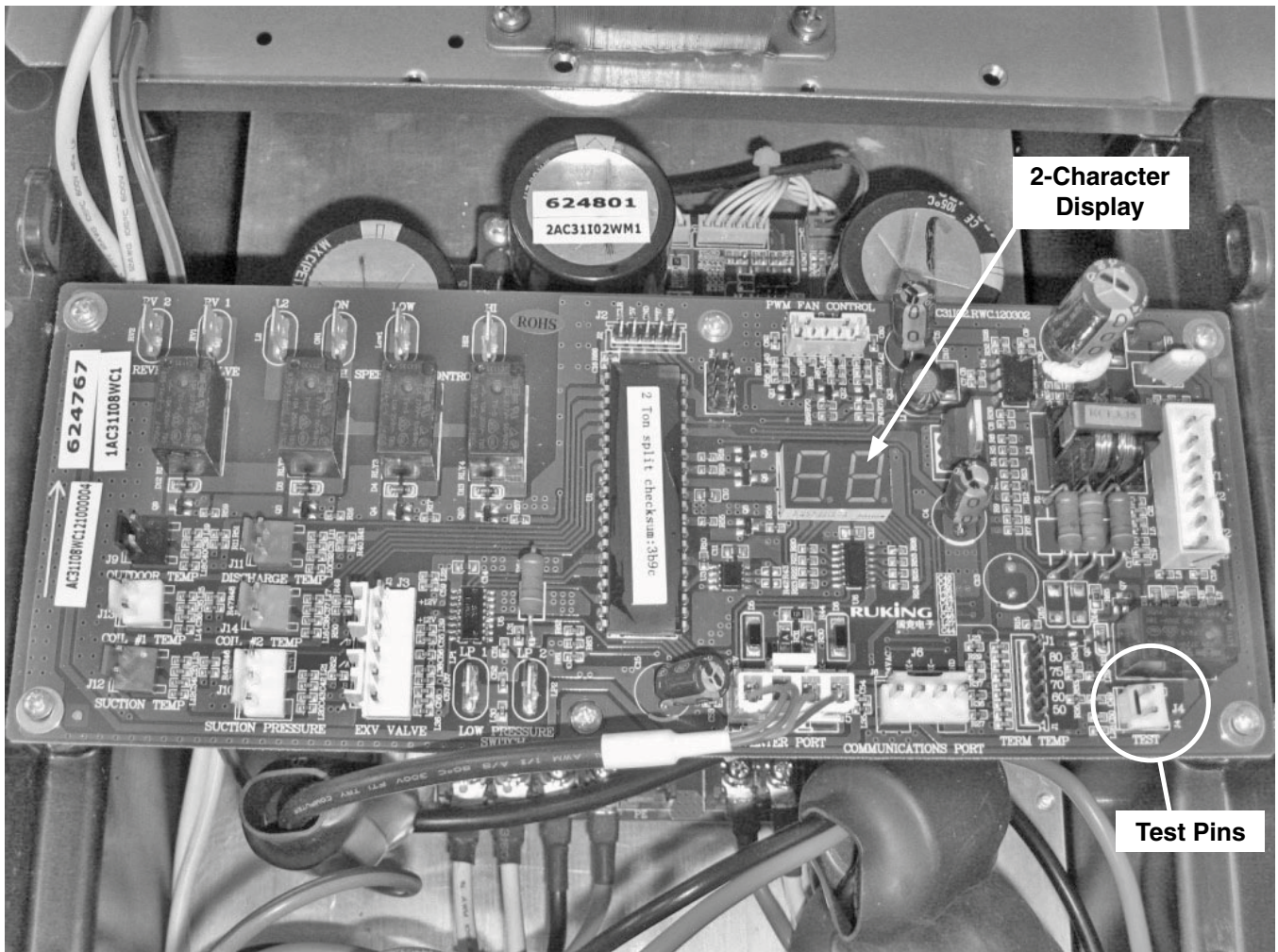
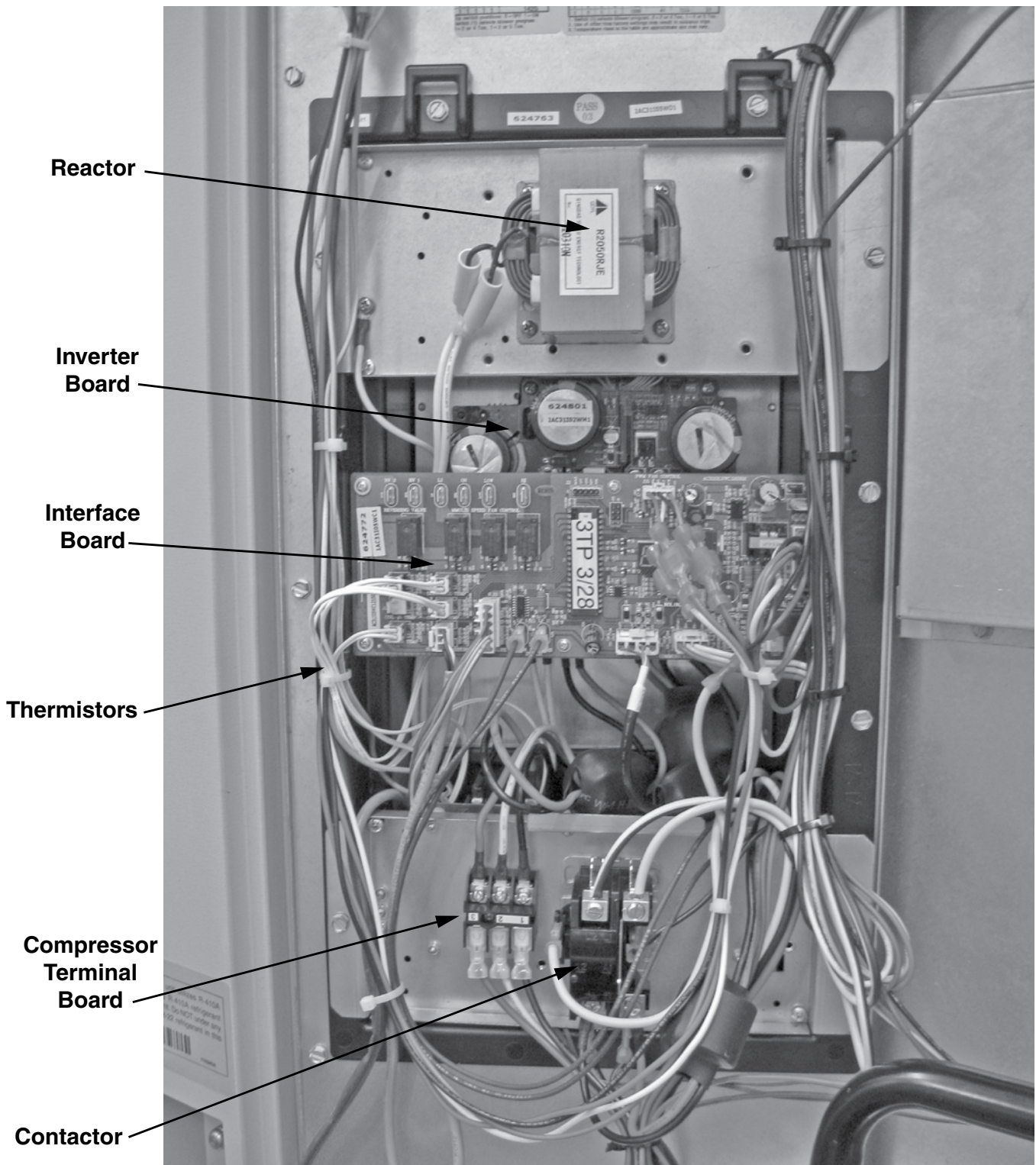

Figure 14. Interface Board in Control Panel

2 CHARACTER DISPLAY	CAPACITY STAGE OR STATUS
[1	Cooling, Stage One Call, Low
[2	Cooling, Stage One Call, Intermediate
[3	Cooling, Stage One Call, Low High
[4	Cooling, Stage Two Call, Nominal High
[5	Cooling, Stage Two Call, Boost
[-- dL or OL	Startup Delay (5 Minutes)
-	System Powered but Idle
Lt	Cooling Low Temperature Lockout (< 50 ° F)

Table 18. Interface Board Status Codes



* 5 Ton inverter assembly has additional components: Contactor, PTCR, and Fan Terminal Block

**Figure 15. R6GI Inverter Assembly
(2, 3 & 4 Ton*)**

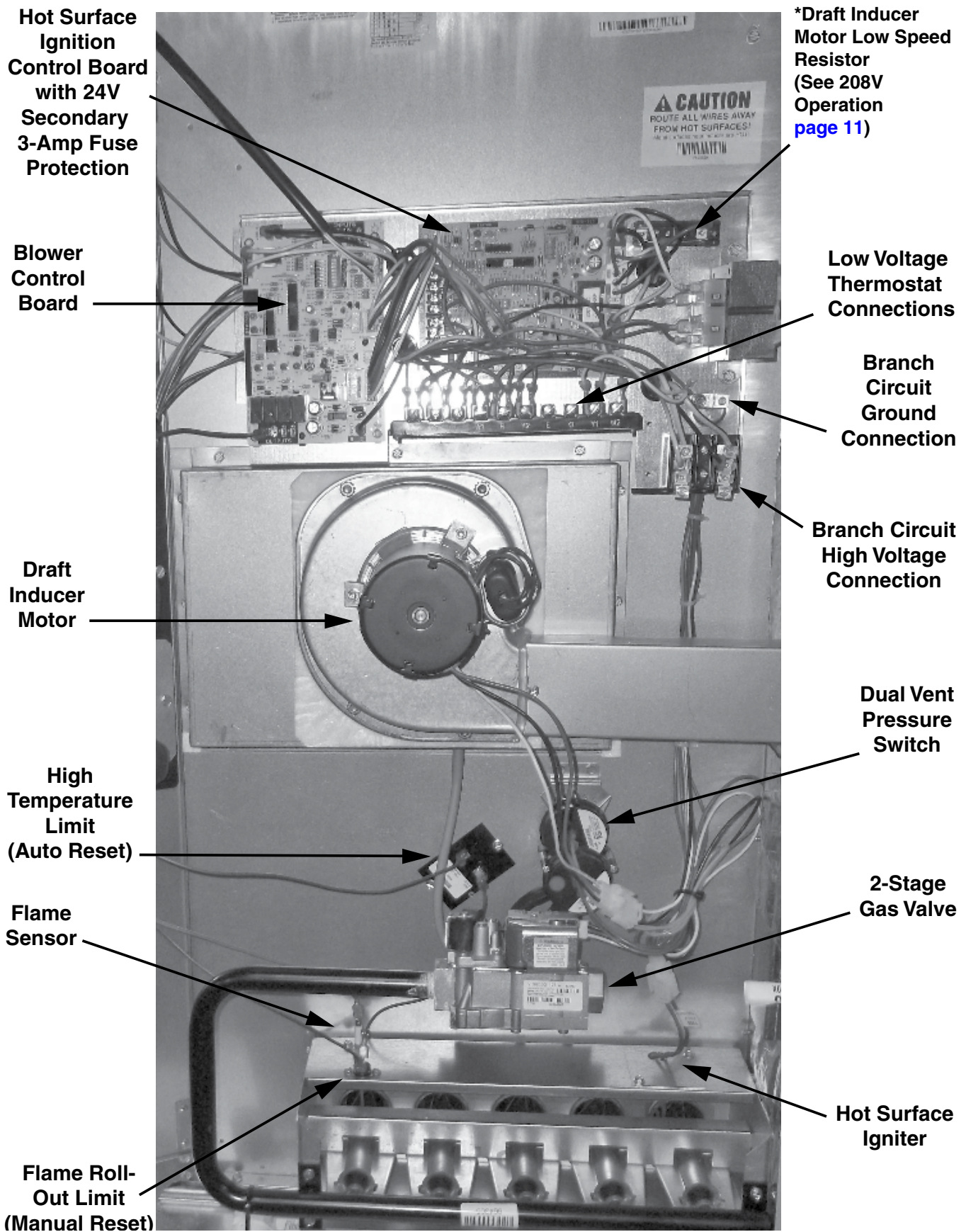

Figure 16. R6GI Typical Heat Exchanger Assembly

WIRING DIAGRAM

R6G1/PPG2GI - 2-4 Ton Package Gas/Electric

Line Voltage 208/230 VAC

1 PHASE / 60 Hz

NOTES:

1. Disconnect all power before servicing.
2. For supply connections use copper conductors only.
3. Not suitable on systems that exceed 150 volts to ground.
4. For replacement wires use conductors suitable for 105 deg.C.
5. For ampacities and overcurrent protection, see unit rating plate.
6. For 208-230V Models only. For 208V operation remove wire from 230V tap and place on 208V tap.
7. For 208V operation, inducer motor low speed resistor must be by-passed. Remove red wire from resistor block and connect to piggyback terminal on opposite side.
8. Ferrite chokes are shown by an ellipse enclosing wires. The number of turns per wire through the choke is shown by (X), for example.
9. Wire harnesses not used on 4T models.

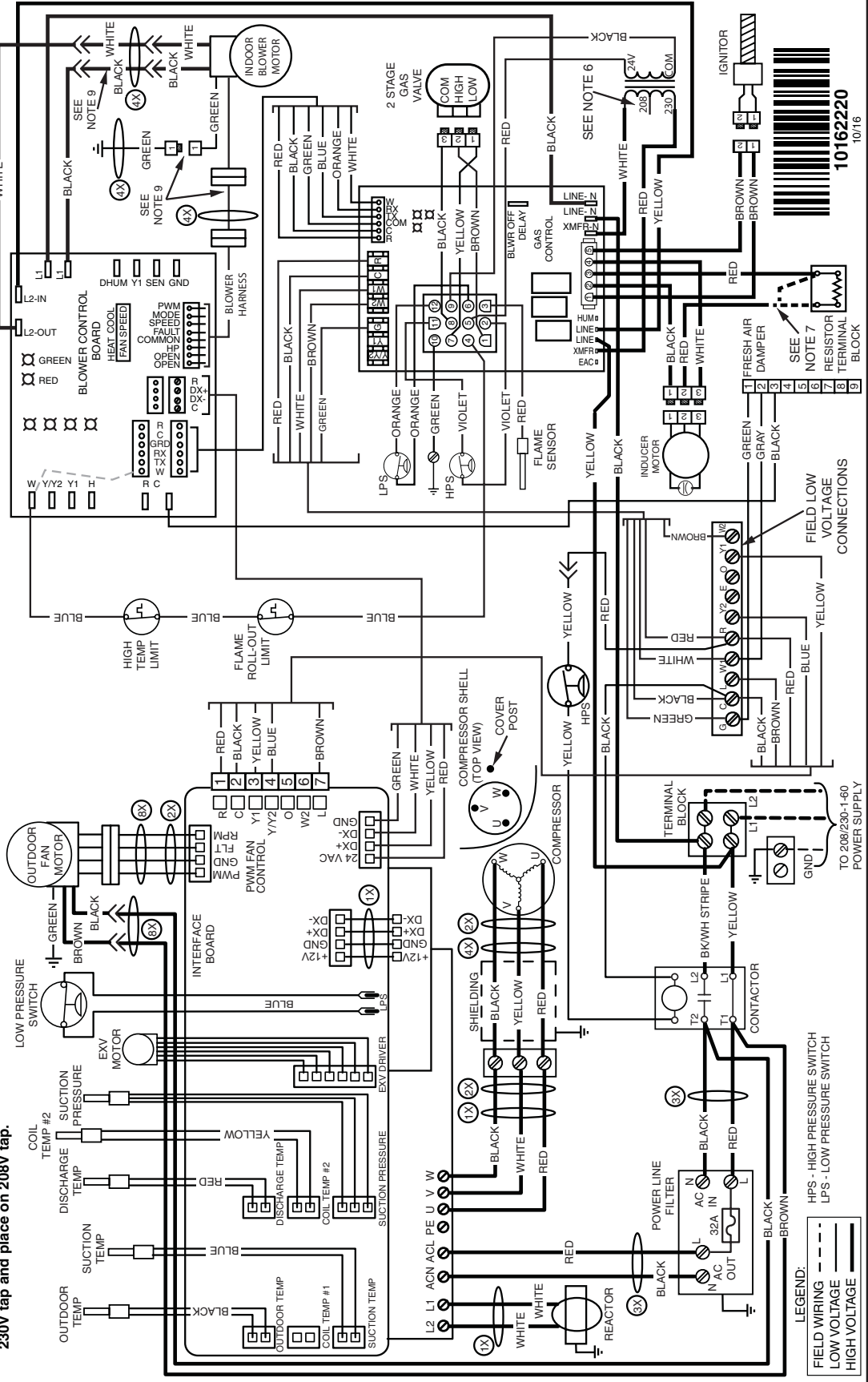

Figure 17. Wiring Diagram (2, 3, & 4 Ton) with Two Stage Cool, Two Stage Heat

WIRING DIAGRAM

R6G/PPG2GI - 5 Ton Package Gas/Electric

Line Voltage 208/230 VAC

1 PHASE / 60 Hz

NOTES:

1. Disconnect all power before servicing.
2. For supply connections use copper conductors only.
3. Not suitable on systems that exceed 150 volts to ground.
4. For replacement wires use conductors suitable for 105 deg.C.
5. For ampacities and overcurrent protection, see unit rating plate.
6. For 208V Models only. For 208V operation remove wire from 230V tap and place on 208V tap.
7. For 208V operation, inducer motor low speed resistor must be by-passed. Remove red wire from resistor block and connect to piggyback terminal on opposite side.
8. Ferrite chokes are shown by an ellipse enclosing wires. The number of turns per wire through the choke is shown by (X), for example.

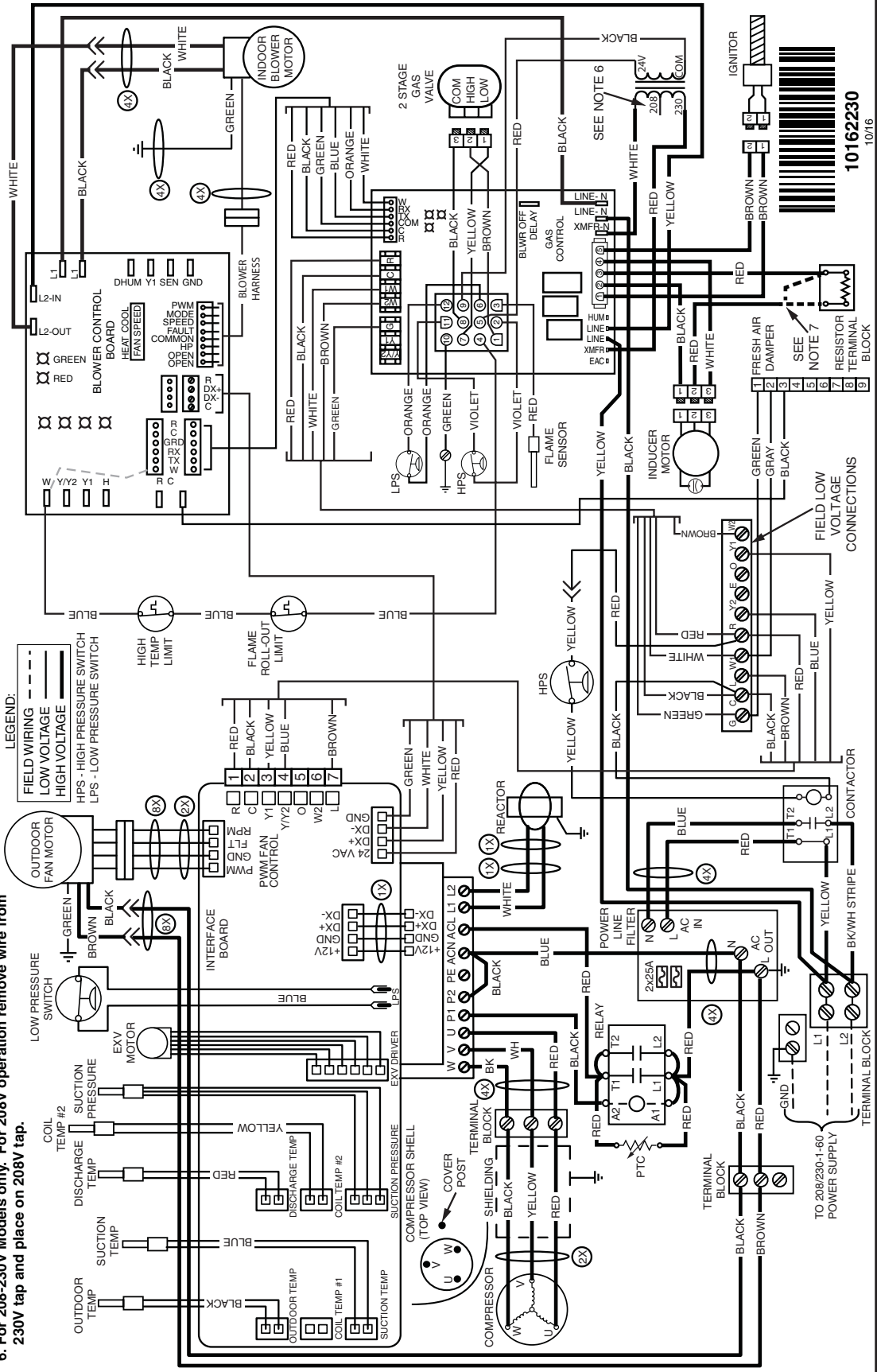

Figure 18. Wiring Diagram (5 Ton) with Two Stage Cool, Two Stage Heat

REFRIGERANT CHARGING

WARNING:

These units are shipped fully charged with R-410A refrigerant and ready for installation. When a system is installed according to these instructions, no refrigerant charging is required. If repairs make it necessary for evacuation and charging, it should only be done by qualified, trained personnel thoroughly familiar with this equipment. Some local codes require licensed installation/service personnel to service this type of equipment. Under no circumstances should the owner attempt to install and/or service this equipment. Failure to comply with this warning could result in property damage, personal injury, or death.

CAUTION:

This unit uses R-410A refrigerant. DO NOT use any other refrigerant in this unit. Use of another refrigerant will damage the unit.

For charging in the field, the unit should be run with a call for second stage cooling with both **Y1** and **Y2** outputs energized. This may be accomplished by setting the thermostat to cool with a setpoint substantially lower than room temperature. This will provide 60 minutes of operation at the nominal rating speed (interface board display “**E4**”) before there is a speed change (to a higher speed- “**E5**”). If the speed change to “**E5**” occurs before the charging process is complete, turn the system off, then restart the process. Refer to the charge amount listed on the units data label.

Alternate Procedure for Charging Air Conditioner in Cooling Mode (with outdoor temperatures above 60° F) Based on Subcooling

While charging based on refrigerant weight shown on unit rating label is preferred, this method is acceptable. Use this method when the outdoor temperature is 60° F or higher to verify the correct charge in cooling mode. The indoor temperature should be between 70° F and 80° F.

1. Connect the gauge manifold to the liquid and vapor service valves. See [Figure 5 \(page 10\)](#).
2. Start the system in cooling mode. Allow the system to run 15 minutes to stabilize.
3. Record the liquid refrigerant pressure in psig at the service valve.
4. Record the liquid refrigerant line temperature in °F at the service valve.

5. Using the temperature value recorded, determine the corresponding liquid refrigerant pressure from the curve in the appropriate charging chart. See [Figure 19](#), [Figure 20 \(page 38\)](#), & [Figure 22 \(page 39\)](#).
6. If the pressure measured in step 3 is less than the required liquid refrigerant pressure determined in step 5, then refrigerant needs to be added.
7. If the pressure measured in step 3 is greater than the required liquid refrigerant pressure determined in step 5, then the system is over-charged.
8. Add or remove charge from the system depending on the measurements recorded. Allow the system to stabilize for 15 minutes before taking the next readings.

Application Notes & Charging Charts (Cooling Mode Only)

This equipments cooling system contains refrigerant under high pressure, always use safe practices when servicing the unit. Always review the factory literature and safety warnings prior to servicing.

These units are shipped from the factory with the proper amount and type of refrigerant. Always inspect the unit rating label to determine the units information prior to working on the system. Do not mix different refrigerants or charge the unit with a refrigerant not listed on the unit rating label.

The charging charts ([Figure 19](#), [Figure 20 \(page 38\)](#), & [Figure 22 \(page 39\)](#)) are valid for a variety of indoor, return air conditions and are most highly influenced by the outdoor ambient temperature, outdoor fan operation and the unit operating voltage. Before referencing the charts, always make sure that the compressor circuit is energized on nominal speed (**Y1** & **Y2** energized) and has stable operation. As can be seen in the charging charts, the ideal system sub-cooling can vary over the range of operation. Always reference the charts to determine the ideal amount of sub-cooling for a given liquid pressure. Units charged to other values will not perform at the rated unit efficiency (EER).

To inspect a systems operation, using quality instruments, match the measured liquid temperature to the units chart. The measured liquid pressure reading should be within 3% of the value shown for most installations.

DO NOT use the charts for operating under first stage cooling.

For systems that are operating with more then a 5% deviation, inspect the unit for leaks. Always use safe and environmentally sound methods for refrigerant handling. When repairing system leakages, always utilize a nitrogen (inert) gas to protect the refrigerant system and pressure check the repair before re-charging. Always replace the filter-dryers when performing any repair to the refrigeration system. After completing the repairs, evacuate the system to 350-500 microns and weigh in the refrigerant to the amount specified on the unit rating label.

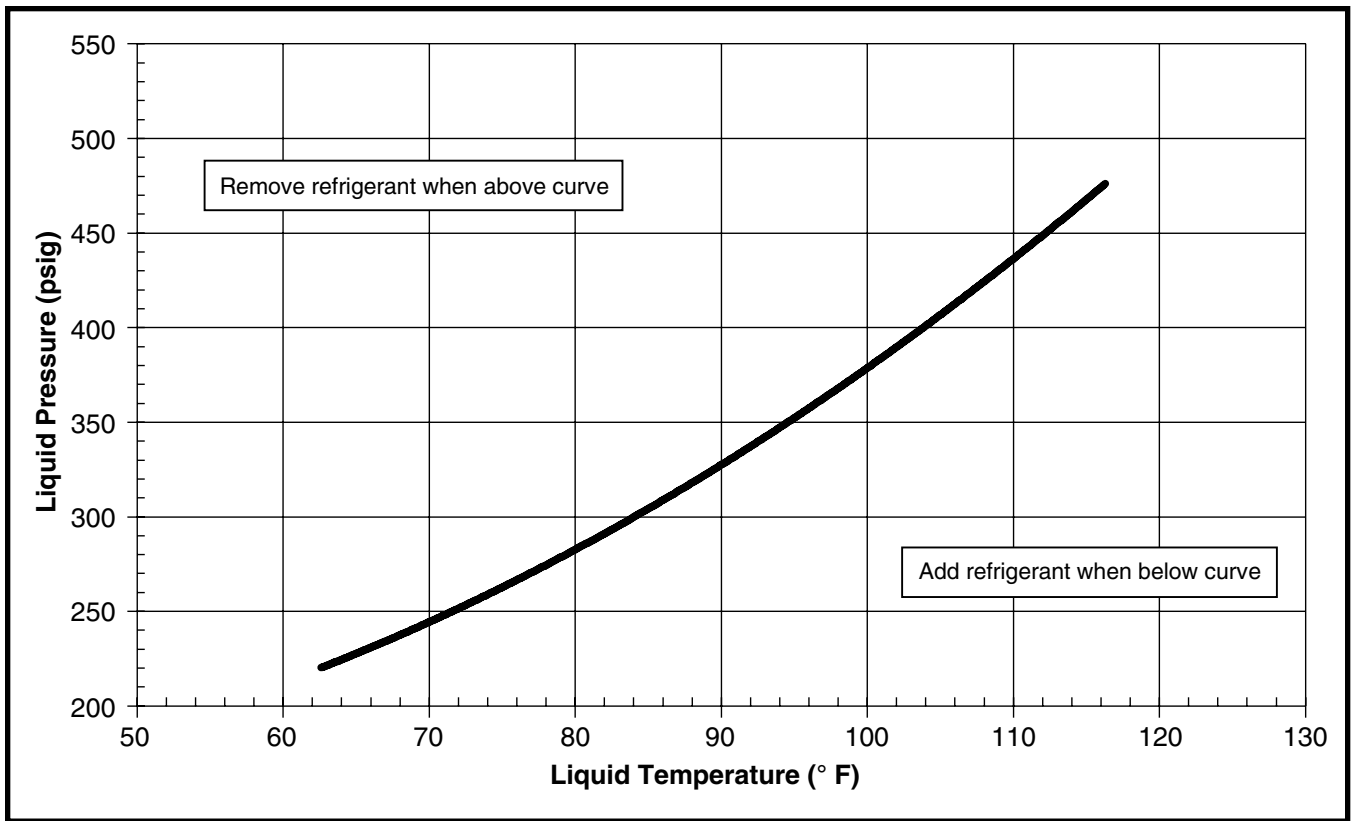

Figure 19. Charging Chart for 2 Ton Units

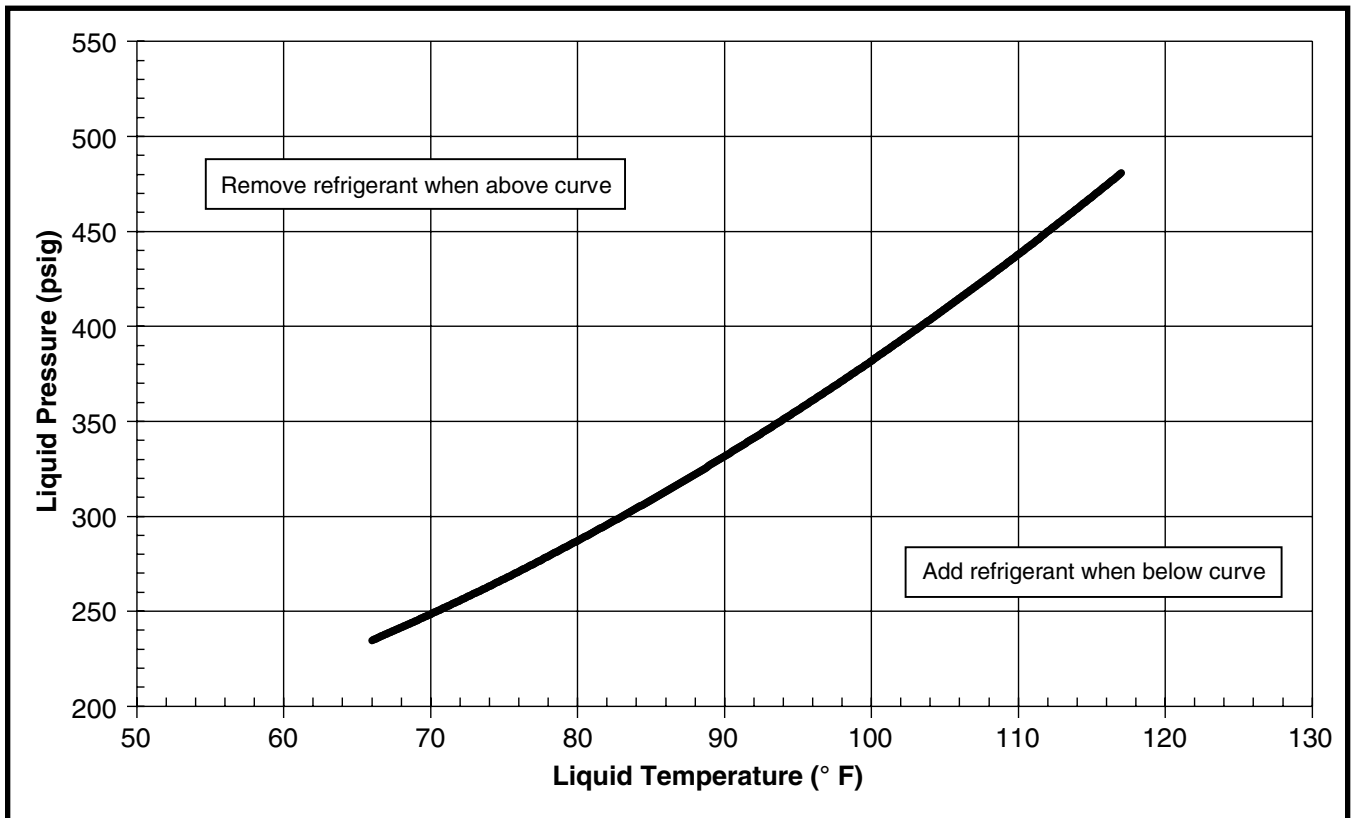

Figure 20. Charging Chart for 3 Ton Units

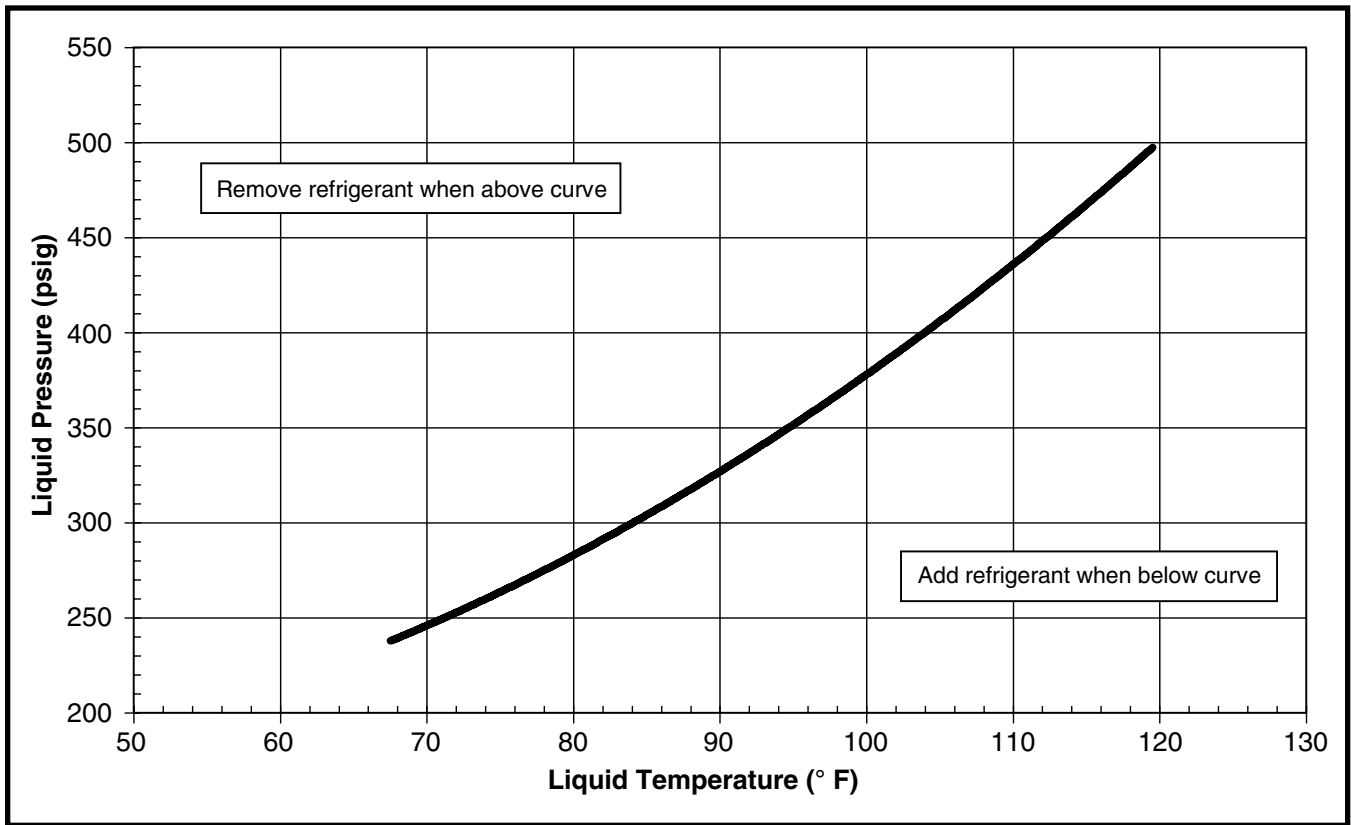

Figure 21. Charging Chart for 4 Ton Units

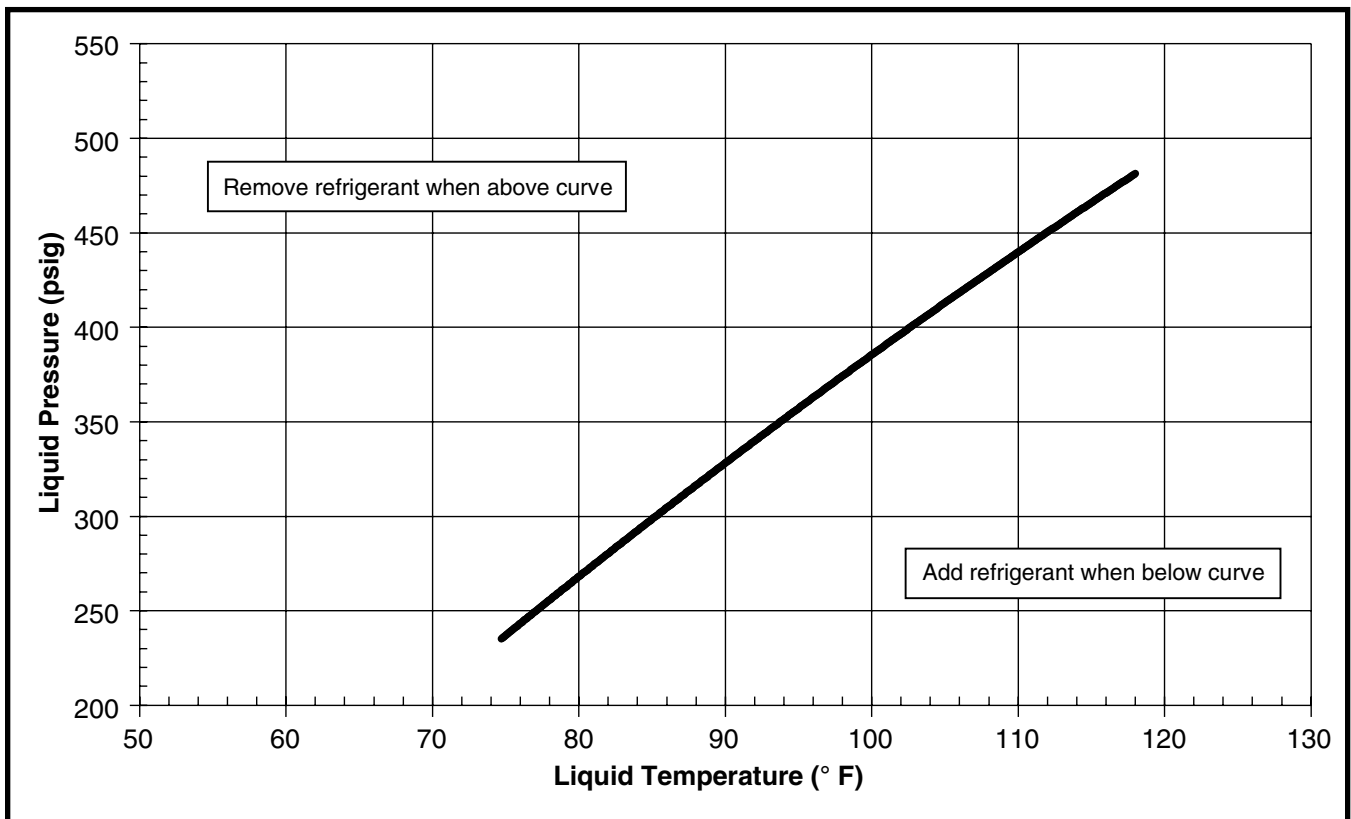
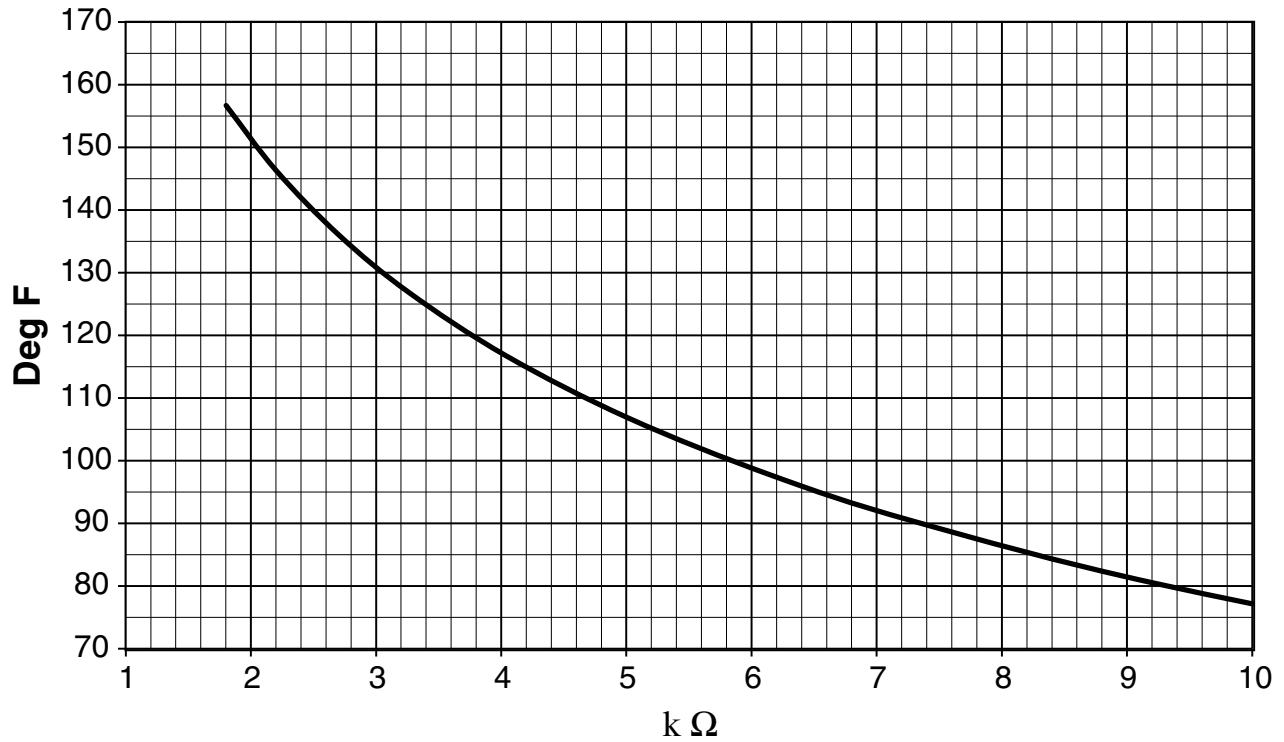

Figure 22. Charging Chart for 5 Ton Units

Temperature vs. Resistance for All Thermistors (Part 1)



Temperature vs. Resistance for All Thermistors (Part 2)

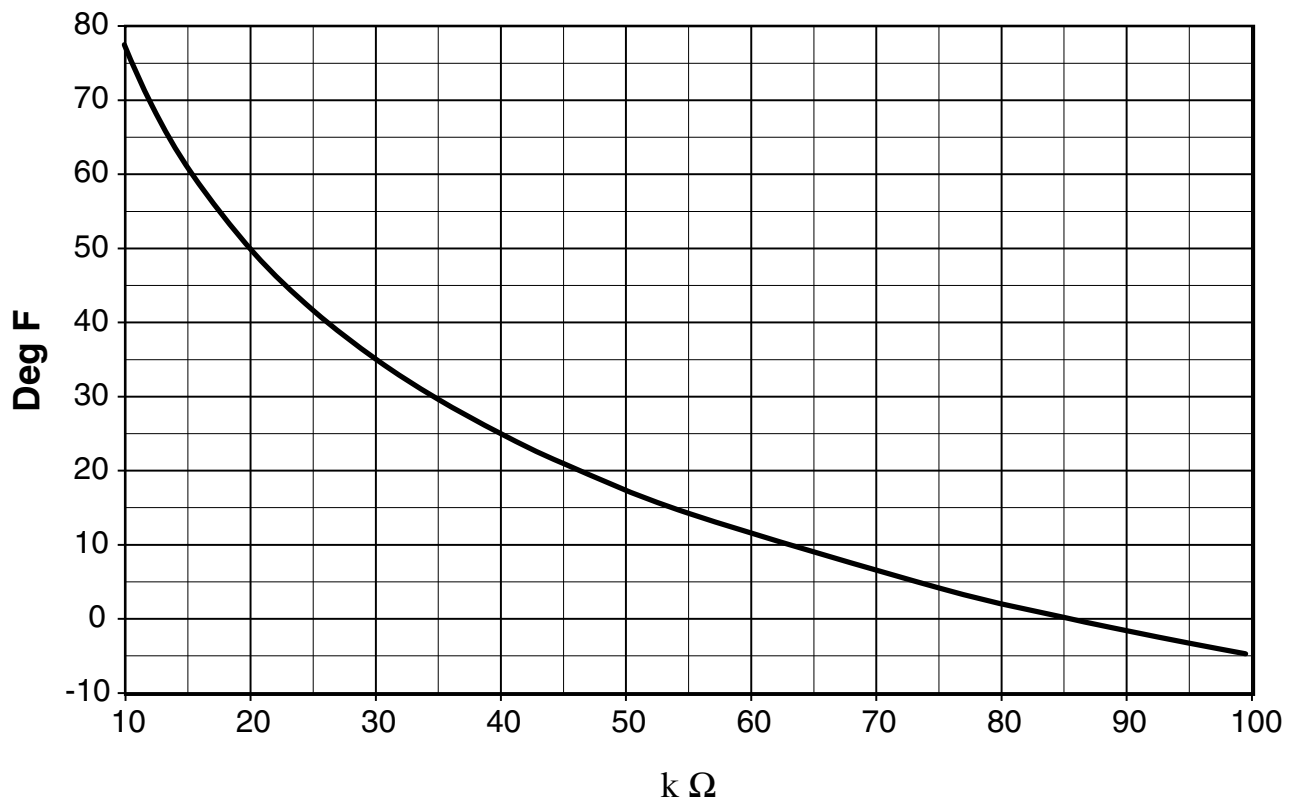

Figure 23. Temperature Sensor Resistance Charts

INSTALLATION CHECKLIST

INSTALLATION ADDRESS:		
CITY	STATE	
UNIT MODEL #		
UNIT SERIAL #		
Unit Installed Minimum clearances per Figure 1 (page 5)?	YES	NO
INSTALLER NAME:		
CITY	STATE	
Has the owner's information been reviewed with the customer?	YES	NO
Has the Literature Package been left with the unit?	YES	NO

VENTING SYSTEM		
Is the vent hood installed?	YES	NO
Is vent hood free from restrictions	YES	NO
Filter(s) secured in place?	YES	NO
Filter(s) clean?	YES	NO

GAS SYSTEM		
Gas Type: (circle one)	Natural Gas	Propane
Gas pipe connections leak-tested?	YES	NO
Gas Line Pressure (in - W.C.):		
Is there adequate fresh air supply for combustion and ventilation?	YES	NO
Installation Altitude (FT.):		
Deration Percentage (%):		
Furnace Input (Btuh):		
Supply Air Temperature (° F):		
Return Air Temperature (° F):		
Temperature Rise (° F):		
DURING FURNACE OPERATION:		
Low fire manifold pressure (in - W.C.):		
High fire manifold pressure (in - W.C.):		

ELECTRICAL SYSTEM		
Electrical connections tight?	YES	NO
Line voltage polarity correct?	YES	NO
Rated Voltage (volts):		
L1-L2 Voltage (volts):		
Has the thermostat been calibrated?	YES	NO
Is the thermostat level?	YES	NO
Is the heat anticipator setting correct?	YES	NO

ATTENTION INSTALLERS:

It is your responsibility to know this product better than your customer. This includes being able to install the product according to strict safety guidelines and instructing the customer on how to operate and maintain the equipment for the life of the product. Safety should always be the deciding factor when installing this product and using common sense plays an important role as well. Pay attention to all safety warnings and any other special notes highlighted in the manual. Improper installation of the furnace or failure to follow safety warnings could result in serious injury, death, or property damage.

These instructions are primarily intended to assist qualified individuals experienced in the proper installation of this appliance. Some local codes require licensed installation/service personnel for this type of equipment. Please read all instructions carefully before starting the installation. Return these instructions to the customer's package for future reference.

REFRIGERATION SYSTEM	
Liquid Pressure @ Nominal Speed (high side):	
Suction Pressure @ Nominal Speed (low side):	

