

# SPECIALTY DRINK SINGLE CUP BREWER CX TOUCH

NEWCO ENTERPRISES INC,  
3650 NEW TOWN BLVD SAINT CHARLES, MO 63301  
1-800-325-7867

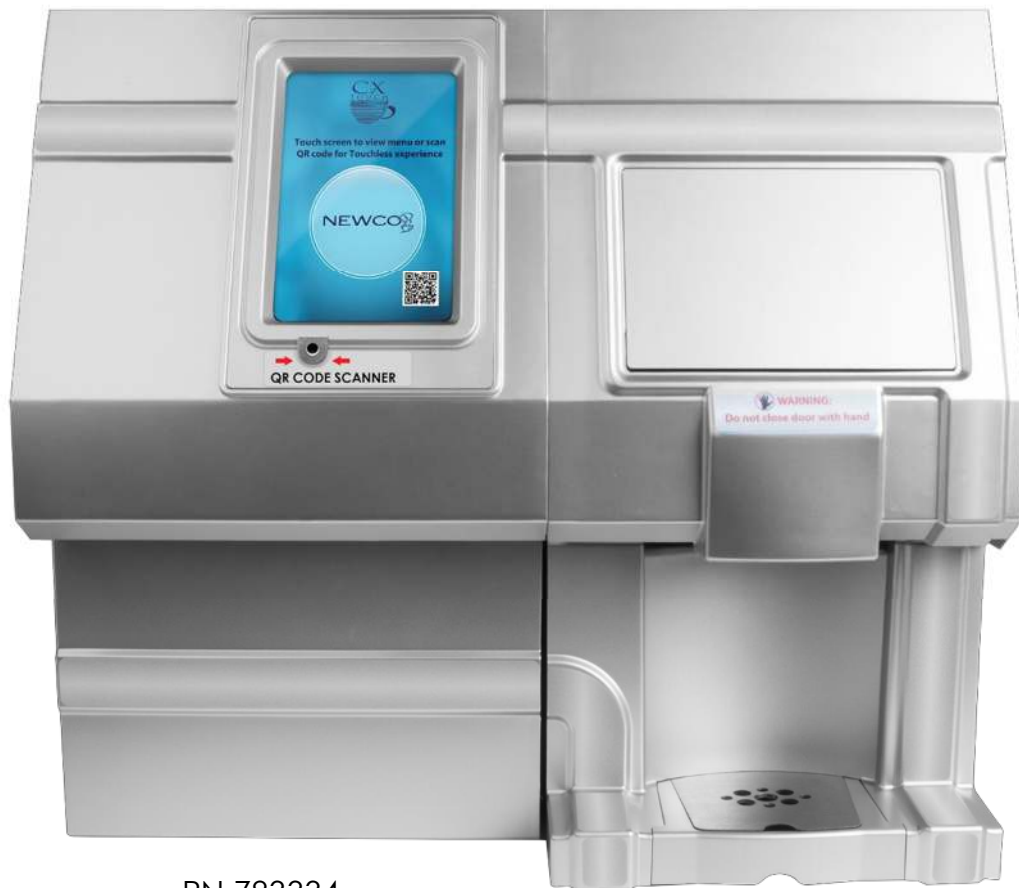

PN 783334

## FEATURES

- QR CAPABILITIES
- AUTO EJECT SYSTEM
- 87 PRE-PROGRAMMED DRINKS AVAILABLE
- TOUCH SCREEN WITH TOUCHLESS OPTIONS
- 1 GALLON TANK SIZE
- POWER SAVE & POWER DOWN OPTION
- PUSH & HOLD HOT WATER BUTTON
- WATER FILTER MONITORING OPTIONS

# NEWCO CONTACT INFORMATION

## ADDRESS

NEWCO ENTERPRISES INC,  
3650 NEW TOWN BLVD SAINT CHARLES, MO 63301

## CUSTOMER SERVICE PHONE

1-800-325-7867

## TECHNICAL SERVICE PHONE

1-800-556-3926

## FAX

1-636-925-0029

## WEBSITE

[newcocooffee.com](http://newcocooffee.com)

## CUSTOMER SERVICE AND SALES EMAIL

[sales@newcocooffee.com](mailto:sales@newcocooffee.com)

## MAINTENANCE INFORMATION

Machine Model \_\_\_\_\_

Service Company Information

---

---

---

---

# TABLE OF CONTENTS

<b>INTRODUCTION &amp; NEWCO PRODUCT WARRANTY</b>	4
WARNING LABELS	5
<b>MACHINE DIMENSIONS &amp; SPECIFICATIONS</b>	6
MACHINE FEATURES	8
<b>MACHINE SET UP</b>	
PLUMBING CONNECTIONS	9
ELECTRICAL HOOK-UP	10
INSTALLATION INSTRUCTIONS	11
MACHINE STARTUP INSTRUCTIONS	12
<b>MACHINE PROGRAMMING</b>	
PROGRAMMING MENUS	12
<b>MACHINE OPERATION</b>	
BREWING DRINKS	19
QR CODE BREWING INSTRUCTIONS	21
<b>SERVICING YOUR MACHINE</b>	
SERVICE NOTES & TROUBLESHOOTING	22
DRAINING THE HOT WATER TANK	25
<b>INSIDE YOUR MACHINE</b>	
MACHINE ACCESS POINTS	26
POD BREW MECHANISM REMOVAL	27
BREW MECHANISM ASSEMBLY	28
WHIPPER ASSEMBLY	29
WHIPPER & CANNISTER ASSEMBLY	30
TANK ASSEMBLY	31
FRONT PANEL ASSEMBLY	32
DOOR ASSEMBLY	33
WIRING DIAGRAM	34

# WARRANTY

*This warranty supersedes all other previous warranties that are currently in manuals. Newco warrants equipment manufactured by it for 1 year parts and labor. Accessories, Dispensers, and Display Tablets - 1 Year parts only. Electronic Circuit and Control Boards- 3 years parts, 1 year labor. Equipment manufactured by others and distributed by Newco please see original equipment manufacturers warranty, Newco will follow.*

These warranty periods run from the date of sale Newco warrants that the equipment manufactured by it will be commercially free of defects in material and workmanship existing at the time of manufacture and appearing within the applicable warranty period. This warranty does not apply to any equipment, component or part that was not manufactured by Newco or that, in Newco's judgment, has been affected by misuse, neglect, alteration, improper installation or operation, relocation or reinstallation, improper maintenance or repair, incorrect voltage applied to the unit at any time, damage or casualty. This warranty does not apply to any equipment failures related to poor water quality, excessive lime and chlorine and non-periodic cleaning and descaling. Warranty is null and void if muriatic or any other form of hydrochloric acid is used for cleaning or deliming. In addition, this warranty does not apply to replacement of items subject to normal use including but not limited to user replaceable parts such as faucet seat cups, sight gauge tubes, washers, o-rings, tubing, seals, and gaskets.

This warranty is conditioned on the Buyer 1) giving Newco prompt notice of any claim to be made under this warranty by telephone at (800) 556-3926 or by writing to **3650 New Town Blvd, Saint Charles, MO 63301**; 2) if requested by Newco, shipping the defective equipment prepaid to an authorized Newco service location; and 3) receiving prior authorization from Newco that the defective equipment is under warranty.

THE FOREGOING WARRANTY IS EXCLUSIVE AND IS IN LIEU OF ANY OTHER WARRANTY, WRITTEN OR ORAL, EXPRESS OR IMPLIED, INCLUDING, BUT NOT LIMITED TO, ANY IMPLIED WARRANTY OF EITHER MERCHANTABILITY OR FITNESS FOR A PARTICULAR PURPOSE. The agents, dealers or employees of Newco are not authorized to make modifications to this warranty or to make additional warranties that are binding on Newco. Accordingly, statements by such individuals, whether oral or written, do not constitute warranties and should not be relied upon.

If Newco determines in its sole discretion that the equipment does not conform to the warranty, Newco, at its exclusive option while the equipment is under warranty, shall either 1) provide at no charge replacement parts and/or labor (during the applicable parts and labor warranty periods specified above) to repair the defective components, provided that this repair is done by a Newco Authorized Service Representative; or 2) shall replace the equipment or refund the purchase price for the equipment.

THE BUYER'S REMEDY AGAINST NEWCO FOR THE BREACH OF ANY OBLIGATION ARISING OUT OF THE SALE OF THIS EQUIPMENT, WHETHER DERIVED FROM WARRANTY OR OTHERWISE, SHALL BE LIMITED, AT NEWCO'S SOLE OPTION AS SPECIFIED HEREIN, TO REPAIR, REPLACEMENT OR REFUND.

In no event shall Newco be liable for any other damage or loss, including, but not limited to, lost profits, lost sales, loss of use of equipment, claims of Buyer's customers, cost of capital, cost of down time, cost of substitute equipment, facilities, or services, or any other special, incidental or consequential damages.

**WARNING: Read and follow installation instructions before plugging or wiring in machine to electrical circuit. Warranty will be void if machine is connected to any voltage other than that specified on the serial tag. Machine must be plugged into a grounded outlet.**

## WARNING LABELS

**NOTICE:** Read and follow all warnings posted on this machine. Do not damage or destroy these warnings as they are for your protection.

This machine is intended to brew an 8 to 12 ounce single serving drink into a cup. This machine will also dispense hot water for customer convenience. It is intended for indoor use only, on a sturdy counter or shelf.



PN 101025

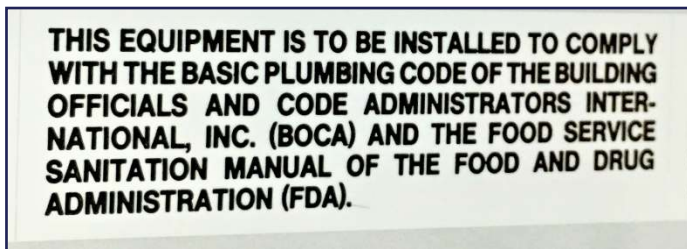

PN 101012

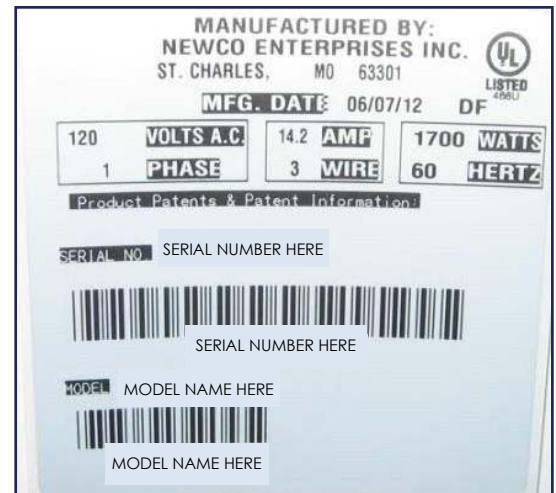

SERIAL TAG EXAMPLE



PN 100817



PN 100821

# MACHINE DIMENSIONS & SPECIFICATIONS

## TANK WATTAGE

120 V AC 1700W HEATER 15 A USA POWER SUPPLY

## TANK CAPACITY

1 GALLON TANK

## 8-12 OZ CUP SIZE

## TEMPERATURE RANGE

180°-205°F

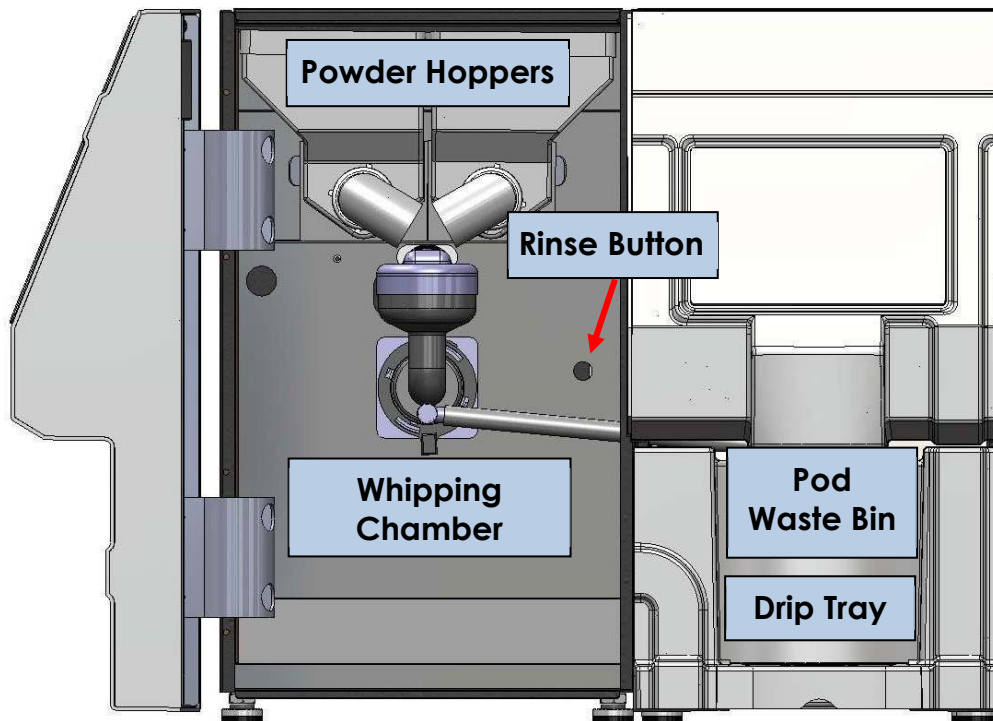
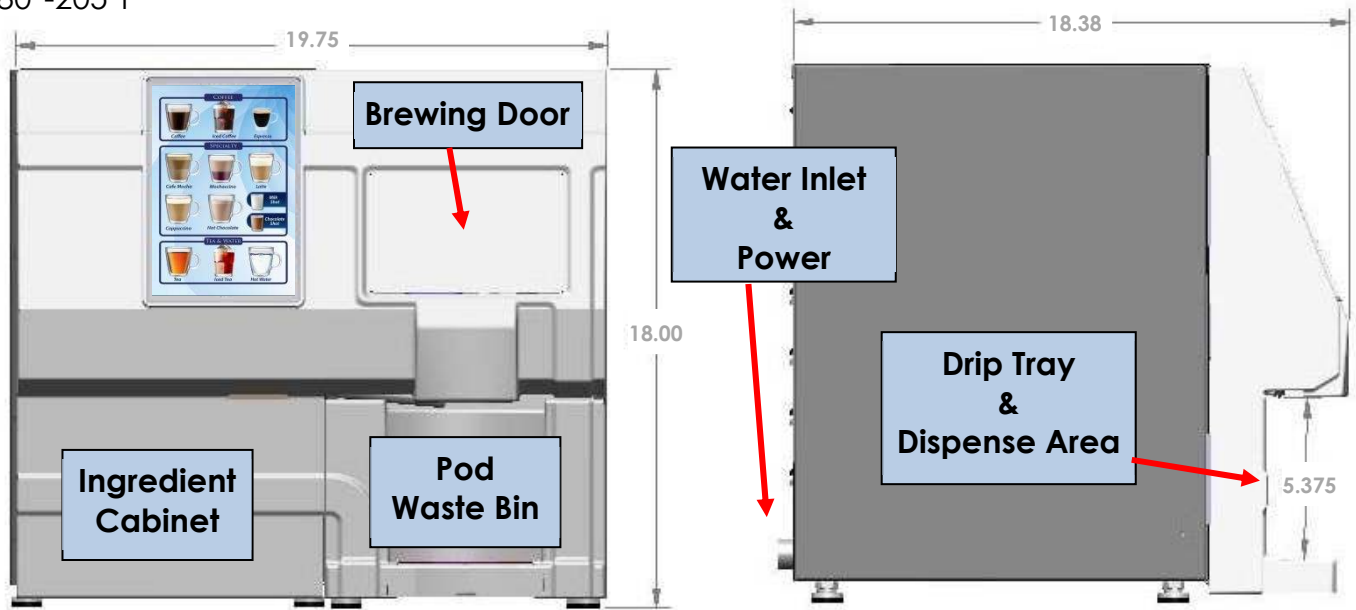

## PASS THROUGH DIMENSIONS

To convert your CX Touch to a pass through, order Kit PN 780810

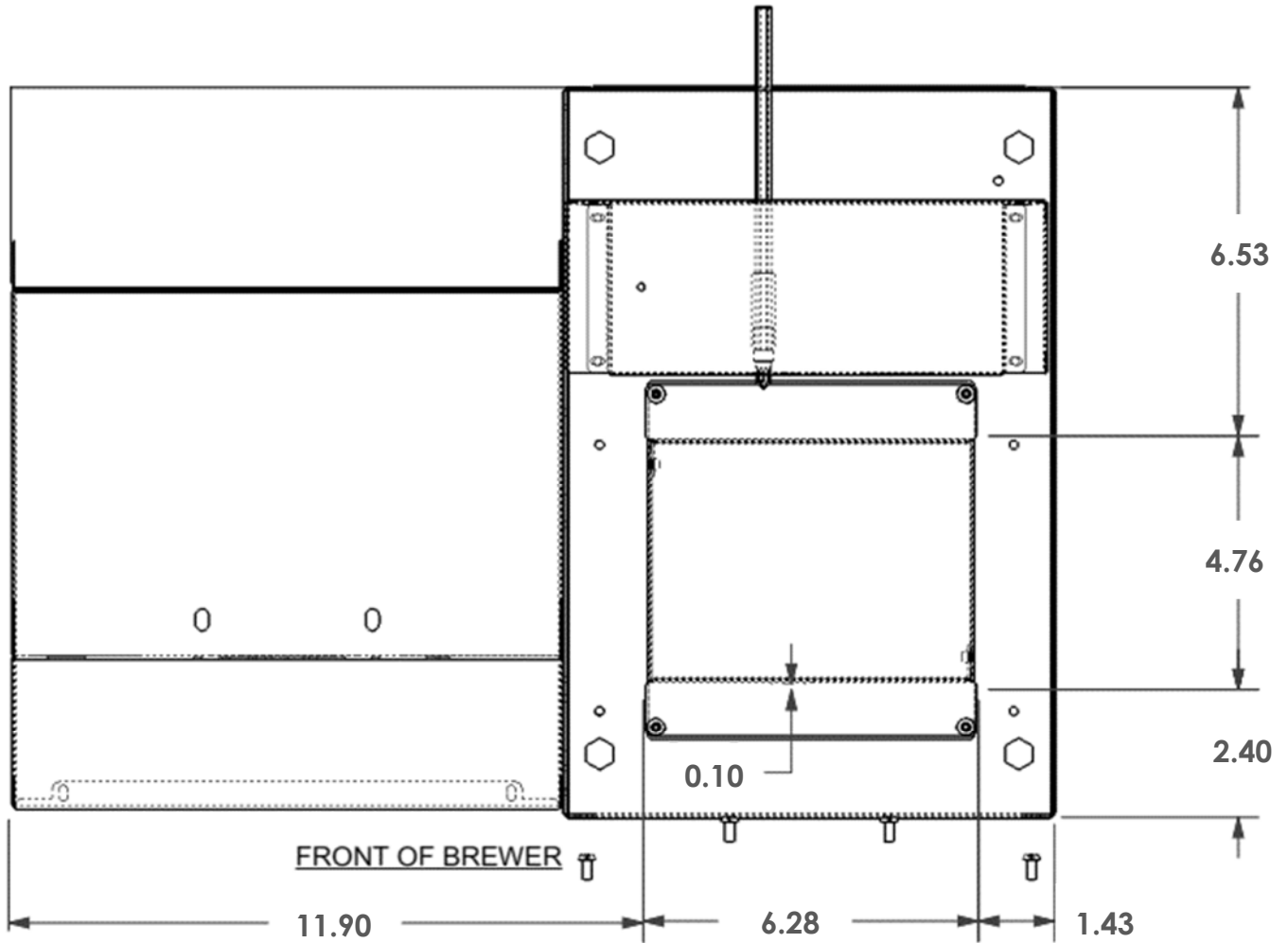

## MACHINE FEATURES

- TOUCH SCREEN DISPLAY
- AUTOMATIC POD MECHANISM
- POD WASTE BIN COUNT & COUNT RESET
- 87 PRE-PROGRAMMED DRINKS AVAILABLE
- WHIPPER RINSE BUTTON
- INDEPENDENT POWDER HOPPER COUNTDOWN & RESET OPTION
- CUSTOM CALL FOR SERVICE NUMBER OPTION
- POWER SAVE & POWER DOWN OPTION
- WATER FILTER MONITORING OPTIONS
- POD WASTE BIN SENSOR
- POD AUTO EJECTION SYSTEM
- BREW DISPENSE LIGHT
- PUSH & HOLD HOT WATER BUTTON
- COFFEE VOLUME FLOWMETER CONTROL
- DUMP VALVE DELIVERY FOR POWDERS
- ABILITY TO TURN ON OR OFF DRINK SIZES AND DRINK STRENGTHS
- ABILITY TO TURN ON OR OFF TEA OR ESPRESSO RECIPES
- QR CAPABILITIES

# MACHINE SET UP

## PLUMBING CONNECTIONS

This machine must be connected to a cold-water system with operating pressure between 20 and 90 psi (138 and 620 kPa) from a 1/2" or larger supply line. A shut-off valve should be installed in the line before the machine. Install a regulator in the line when pressure is greater than 90 psi (620 kPa) to reduce it to 50 psi (345 kPa). The water inlet fitting is 1/4" flare.

A loose coil of copper tubing in the water line will allow movement of the machine to easily clean the countertop underneath.

*Note: Water pressure should be at least 20 lbs. For less than a 25 ft run, use 1/4" copper tubing and connect to 1/2" or larger water line. For longer runs, use 3/8" copper tubing & connect to 1/2" or larger water line and provide an adapter fitting for connection to the brewer. Newco does not recommend the use of a saddle valve to install the brewer. The size and shape of the hole made in the supply line by this type of device may restrict water flow.*

This equipment must be installed to comply with the Basic Plumbing Code of the Building Officials and Code Administrators International, Inc. (BOCA) and the Food Service Sanitation Manual of the Food and Drug Administration (FDA). For models installed outside the U.S.A., comply with the applicable Plumbing/ Sanitation Code.

**WARNING:** *Read and follow installation instructions before plugging or wiring in machine to electrical circuit. Warranty will be void if machine is connected to any voltage other than that specified on the serial tag. Machine must be plugged into a grounded outlet.*

## PLUMBER'S INSTALLATION INSTRUCTIONS

**CAUTION:** *Disconnect power to machine before proceeding with plumbing installation.*

1. Attach water line to your water filter, then flush a small amount of water through the filter.
2. Flush water line before installing machine. Machine should be connected to COLD WATER LINE ONLY. Water line must supply a minimum of 1/2 GPM.
3. Water pressure should be at least 20 lbs. For less than a 25 ft run, use 1/4" copper tubing and connect to 1/2" or larger water line. For longer runs, use 3/8" copper tubing & connect to 1/2" or larger water line and provide an adapter fitting for connection to the brewer.  
A dedicated water line is necessary for this machine.
4. If installed with saddle valve, the valve should have a minimum of 1/8" porthole for up to 25 ft run, and 5/16" porthole for over 25 ft runs.
5. Turn on water supply and check for leaks.

*Manufacturer recommends connecting to copper tubing.*

## ELECTRICAL HOOK-UP

WARNING: *The brewer must be disconnected from the power source until specified in Installation Instructions.*

Determine the available on-site electrical requirements.

Refer to Data Plate on the brewer, and local/national electrical codes, to determine circuit requirements.

CAUTION – *Improper electrical installation will damage electronic components.*

## BREWER SET UP INSTRUCTIONS

CX Touch battery eliminated units operate differently than older units that contain batteries in the display tablet. It is no longer necessary or desirable to use the power switch on the display tablet. The display tablet will power on and off with the brewer automatically. Note that since the display tablet does not contain a battery, the tablet will go through a bootup sequence whenever the brewer is powered on.

*Note: This machine is designed to be run with power turned on at all times.*

## INSTALLATION INSTRUCTIONS

**WARNING:** Read and follow installation instructions before plugging in machine to electrical circuit. Warranty will be void if machine is connected to any voltage other than that specified on the nameplate serial tag.

1. Machine must be on a flat and level surface. Plug in machine to appropriate voltage as noted on the brewer serial tag. Serial tag is located on right side of machine, near the bottom rear.
2. With water line connected, turn machine power ON (power switch located lower right rear of machine). Install drip tray and drip tray grate under brew area (slide tray between guide rails until seated).
3. Tank will automatically fill, and machine will start heating. If tank does not fill in 4 minutes, a "tank fill error" will occur.  
*Due to large tank capacity, fill time out error may occur on startup. Please turn machine off, and then back on to clear the error and continue filling.*
4. Allow 10 to 15 minutes for water in tank to heat to brewing temperature. (Additional water may drip into drip tray on initial expansion of water in the tank). This will not occur thereafter.
5. Heater will turn on when water in tank is at probe level.

*In higher altitude locations (3000 feet above sea level) the temperature may need to be adjusted lower in Programming Setup (page 15) to prevent boiling:*

<b>Brew water temperature is factory set at 200°F (92.3°C) Areas of high altitude will require lowering this temperature to prevent boiling. This chart should be used as a guide when readjusting the brew water temperature.</b>		
<b>Altitude (Feet)</b>	<b>Boiling point of water °F (°C)</b>	<b>Recommended water temperature °F</b>
-1000	213.8 (101.0)	200 (93.3)
-500	212.9 (100.5)	200 (93.3)
0	212.0 (100.0)	200 (93.3)
500	211.1 (99.5)	200 (93.3)
1000	210.2 (99.0)	200 (93.3)
1500	209.3 (98.5)	200 (93.3)
2000	208.4 (98.0)	200 (93.3)
2500	207.4 (97.4)	200 (93.3)
3000	206.5 (96.9)	199 (92.8)
3500	205.6 (96.4)	198 (92.2)
4000	204.7 (95.9)	197 (91.7)
4500	203.8 (95.4)	196 (91.1)
5000	202.9 (94.9)	195 (90.6)
5500	201.9 (94.4)	195 (90.6)
6000	201.0 (93.9)	194 (90.0)
6500	200.1 (93.4)	193 (89.4)
7000	199.2 (92.9)	192 (88.9)
7500	198.3 (92.4)	191 (88.3)
8000	197.4 (91.9)	190 (87.8)
8500	196.5 (91.4)	189 (87.2)
9000	195.5 (90.8)	188 (86.7)
9500	194.6 (90.3)	187 (86.1)
10000	193.7 (89.8)	186 (85.6)

## MACHINE STARTUP INSTRUCTIONS

1. Fill and install 2lb hoppers with nozzles turned up, Chocolate on left, and Milk on right. Make sure tab on bottom of hopper is seated in slot in sheet metal. Slight manual rotation of the auger gear may be necessary to seat hopper in correct location.
2. Rotate dispense nozzles down into whipper bowl.
3. Ensure that there is a proper water supply connected to the machine and water is turned on. Ensure that the machine is plugged into a proper power outlet and there is power supplied to the machine.
4. Turn machine power switch on. Machine will start filling.

The Touch Screen Display will indicate when the machine is filling.

Heater will turn on when water in tank is at probe level. The screen will display "Heating: Please Wait". The heating process can take 10-15 minutes before the machine is ready to brew.

When the hot water tank reaches brewing temperature, display will change to the Drink Instruction Screen. The machine is now ready for operation.

Touching the screen will bring up the Drinks Menu Selection Screen.

Place an empty cup in the brewing area, open the powdered hopper door, and press the "Rinse" button next to the whipper bowl until the water runs clear.

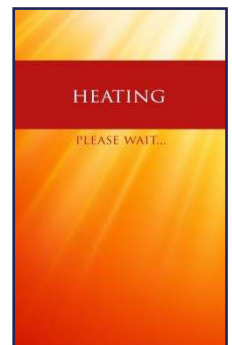
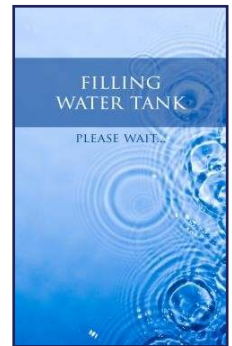

# MACHINE PROGRAMMING

## PROGRAMMING MENUS

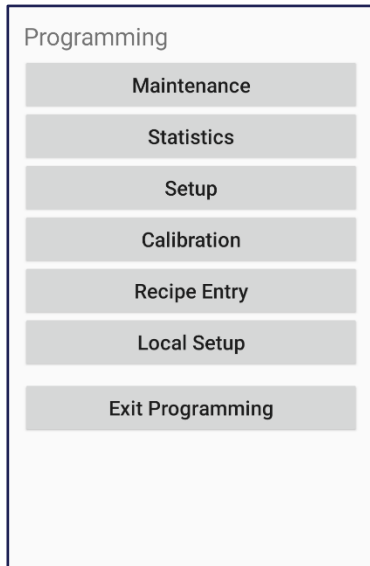

Lower Level Programming

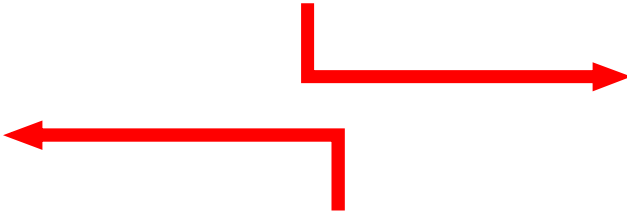

Upper Level Programming



Tap the Specialty header 3 times, then tap Tea & Water header 3 times, to enter Upper Level Programming mode.



Tap the Tea & Water header 3 times to enter programming mode.

*If a brewing icon is accidentally touched, use the back arrow to return to the Drink Selection Menu.*

Tap the upper left corner 3 times, then tap the lower right corner 3 times, to enter Upper Level Programming mode.



Tap the lower right corner 3 times to enter Lower Level Programming mode.

## MAINTENANCE

Remaining gallons on the filter will only show up if you set your filter size in Programming Setup. This is a countdown to show the number of gallons left before you need to change the water filter.

Reset the Water Filter countdown after changing filters.

The Whipper Seal needs to be changed after 5000 specialty drink cycles.

Reset the Whipper Seal countdown after changing the Whipper Seal.

Exit will take you to the Programming Menu.

Maintenance	
Water Filter Remaining Gal	0
<b>Water Filter Reset</b>	
Whipper Seal Remaining	0
<b>Whipper Seal Reset</b>	
<b>Exit Maintenance Mode</b>	

## STATISTICS

This screen shows the various statistics the CX Touch can track.

Please note that Total Water Usage is not resettable.

Please also note that Chocolate and Milk grams remaining will only be recorded if Powder Tracking is enabled in the Setup menu, located in the main Programming Menu.

Exit will take you to the main Programming Menu.

Statistics	
Total Run Cycles	0
Pod Brew Cycles	0
Total Water Usage (Gal)	0
Waste Bin Remaining	0
Chocolate Grams Remain	0
Milk Grams Remaining	0
<b>Exit Statistics Mode</b>	

## SETUP

Please note that Newco takes time to develop the default settings for the brewer.

### WATER TEMPERATURE

This entry allows the user to set the brewing temperature within the range of 180°F to 205°F, with the default set at 200°F.

*Higher altitudes: See page 11 for recommended brewing temperatures.*

### WASTE BIN SIZE

This entry represents the number of pods that the waste bin will hold before signaling that the waste bin is full. This can be set between 2 and 50, with the standard waste bin capacity being 30 pods. This count can also be turned off, if you are using a special ordered pass through waste bin (PN 780081).

### AIR BLOW STRENGTH

This entry sets how strong the air pump pushes air, ranging from 3 to 10.

*Note: Too high of an air strength may result in a broken pod.*

### AIR BLOW TIME

This entry changes how long the air pump runs to drain the remaining brew from the pod chamber. This is shown in seconds, and can be set anywhere between 2 and 15 seconds.

### WATER FILTER SIZE

This should be set to OFF, unless an external water filter has been installed on the water line. The CX Touch can accommodate filter sizes between 500 and 3000 gallons. Remaining gallons for the water filter can be tracked, which is shown on the Maintenance screen.

See Page 13.

### CALL FOR SERVICE NUMBER

Allows for Servicer contact information to be entered, up to 34 alpha or numeric characters.

### TOUCHLESS

Allows the user to choose between On (Touchless only), Off, or Combined modes.

### SET DC PUMP SPEED

*Note: Changing the pump speed will effect the speed at which water flows through the brewing mechanism. Water flow speed could negatively effect drink taste profile, and may cause pods to break. It is not recommended to change this setting.*

### ENERGY SAVE MODE

#### OFF

Power stays on, and hot water tank remains at brewing temperature.

#### SEMI

Hot water tank temperature set point is reduced to 180°F until any interaction is detected.

#### FULL

Hot water tank heater is disabled until any interaction is detected.

*Note: After 72 hours of non-use, the heater will automatically turn off. Any interaction will turn the heater back on.*

### ENERGY SAVE TIME

Allows the user to set when selected energy save mode is enabled. The range is 0.5-4.0 hours in 0.5 hour increments.

Setting	Value	Setting	Value
Water Temperature	200	Powder Tracking	OFF
Waste Bin Size #	30	Set DC Pump Speed	50
Air Blow Strength	8	Energy Save Mode	OFF
Air Blow Time	10	Energy Save Time	4.0
Water Filter Size	OFF		
Call for Service Number			
Touchless		Combined	
		Touchless Delay (seconds)	2

Buttons: +, -, Drink Selection Menu, Restore Factory Settings, Exit Setup Mode

## RESTORE FACTORY SETTINGS

This will reset all entries in the Setup screen, other than the Call for Service Number.

*Note: This will not restore settings in any of the other programming sections: Maintenance, Statistics, Recipe Entry, etc.*

## DRINK SELECTION MENU

The Drink Selection screen enables you to turn off a drink type, drink strength, or drink size. It also has the option to set the default cup size.

*Note: At least one size and one strength must be enabled in order to exit this menu. Default cup size must be a size that is enabled, i.e. if only Medium and Large are enabled, default cup size cannot be Small.*

### Drink Selection Menu

Small Cup Config	<input checked="" type="checkbox"/>	Mild Drink Enabled	<input type="checkbox"/>
Medium Cup Config	<input type="checkbox"/>	Regular Drink Enabled	<input type="checkbox"/>
Large Cup Config	<input type="checkbox"/>	Bold Drink Enabled	<input type="checkbox"/>
Iced Coffee Enabled	<input type="checkbox"/>	Default Cup Size	MED
Tea Enabled	<input type="checkbox"/>		
Iced Tea Enabled	<input type="checkbox"/>		

+

-

Exit Drink Selection Menu

## CALIBRATION

Please read all instructions before calibrating your machine.

### AUGER CALIBRATION

1. Ensure hopper is full of powder product.
2. Highlight which auger you are calibrating, then open the door to view the hoppers.
3. Place a container (at least 12 oz) on scale, and tare.
4. Remove whipper chamber, and then place tared container under the elbow of selected hopper.
5. Press "Start Cal Cycle", powder product will begin dispensing into container.
6. Weigh (in grams) the container of powder product and input into calibration screen.
7. Press "Save" to complete auger calibration. Repeat steps for other auger.

**Calibration**

Left Auger Cal Grams	156	Bypass Water Cal Oz.	17.9
Right Auger Cal Grams	90	Set Mixing Bowl Speed	10
Flow Meter Adjust	0	Mixing Bowl Cal Oz.	20.0
Flow Meter Test	0		

+
-
Start Cal Cycle

Exit Calibration Mode

### FLOW METER ADJUST

Please run your machine a few times. Ensure volume dispensed is consistent, so that no further calibration is needed. Please note that running cycles without a pod will yield in approximately ¼ oz more than programmed dispense volume.

The flow adjustment is likely to be around +3 when coming from the factory. If this needs to be adjusted over time, then there could be an issue with hardwater buildup, or possibly a component failure- most likely the pump, or the flowmeter.

*This setting is only to fine tune dispensed volume.*

NOTE: The machine has been calibrated at the factory.

### FLOW METER TEST

The flowmeter test is a diagnostics tool. It is likely only to be run when on the phone with a servicer. Before running, place a container under the dispense area to catch water used in the test. The number on the screen will count up, taking several pauses during the test. Servicers will not need the first number, only the last one.

*Flowmeter math: The number on the screen is the number of rotations the flowmeter counted. Multiply this number by 0.042 to calculate the number of ounces delivered. This should match the measured number of ounces dispensed.*

### MIXING BOWL CALIBRATION

1. Place a container (at least 32 oz) on scale and tare.
2. Place tared container on drip tray to collect water from dispense point.
3. Press "Start Cal Cycle", water will begin dispensing into container.
4. Weigh (in ounces) the container of water and input into calibration screen.
5. Press "Save" to complete mixing bowl calibration.

*Remaining calibration settings will not be used.*

## RECIPE ENTRY

Recipes were developed for optimal taste preference.

It is not recommended to change these settings, as these recipes cannot be restored using factory reset.

*Note: If any changes are made, then save must be pressed to keep the changes.*

### PRE-INFUSION TIME

This parameter sets the amount of time the pre-infusion runs. This can be set between 0 and 100 seconds.

### POD VOLUME

Coffee volume in 0.1 ounces, ranging from 15-120. For a volume of 7.0 oz, this will be set to 70.

### POD RUN TIME

This is the time that water will run through the pod to brew your drink, in 0.1 seconds. Longer times equate to a stronger brew. The range of this parameter is 30-999 seconds. For a run time of 18.0 seconds, this will be set to 180.

### WATER VOLUME

For specialty drinks, this is the amount of water dispensed into the mixing bowl for powders. This parameter ranges from 5-120, with each increment being 0.1 ounces.

If the current recipe is for a non specialty drink, then this parameter is unavailable.

### MILK/ CHOCOLATE RATIO

This ratio is multiplied by the Water Volume to calculate the amount of powder to incorporate into a brewed drink. This setting is done in 0.10 grams, ranging from 0-80.

*Please note that Newco takes time to develop recipes.*

**It is not recommended that the user change any recipe parameters.**

## LOCAL SETUP

### BREWING SCREEN

Choose if slates or a logo is shown while a coffee based drink is brewing.

### LANGUAGE SELECTION

Choose from English only, or French and English combined.

Other features on this screen are for future use only.

*Note: If Network Setup is accidentally pressed, turn the brewer off then back on to return to the drink selection screen.*

The screenshot shows the 'Recipe Entry' screen for a 'Mochaccino 8oz Tpl' recipe. The settings are as follows:

Recipe Name	Mochaccino 8oz Tpl		
Recipe Number	42	Bypass Volume	
Recipe Type	5	Bypass Delay Time	
Pre-Infusion Time	15	Bypass Run Time	
Pod Volume	35	Milk Ratio	35
Pod Delay Time		Chocolate Ratio	60
Pod Run Time	350	Whipper Delay Time	
Water Volume	35	Whipper Run Time	
Water Delay Time		Water Run Time	

At the bottom, there are two buttons: '+', '-' and 'Save Recipe', 'Exit Recipe Entry'.

The screenshot shows the 'Local Setup' screen with the following settings:

Primary Server	192.168.1.10
Secondary Server	barista.newcocooffee.com
Sleep Timeout	2m
Brewing Screen	DFLT
Language Selection	EN

Below the settings are buttons for '+', '-', 'Network Setup', 'Install Logo', 'Load Software Update', 'Install Software Update', and 'Exit Local Setup Mode'.

# MACHINE OPERATION

## BREWING DRINKS

To brew a drink, place a cup in the dispense area first. Make your drink selection using the touch screen tablet, or follow directions on page 21 for touchless options. Place a pod, flat side up, in the brew chamber. Do NOT pinch your pod, it should be flat when placed in the machine. Follow instructions on the screen.

**NOTE:** Machine brews up to 12 oz. Make sure you have an appropriate size cup.

Default settings, on control board assembly PN 782306, for Small, Medium, and Large drinks are 8, 9, and 10 ounces respectively. On special ordered control board assembly PN 782277, default settings are 8, 10, and 12 ounces.

Once a selection is made a Submenu for drink types will appear.



# DRINKS SUBMENU EXAMPLES

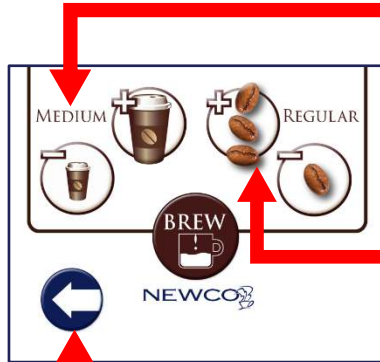

Brew Volume  
Small, Medium, Large

Brew Strength  
Mild, Regular, Bold

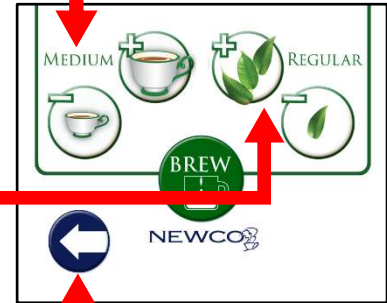

Return to Drink Selection screen

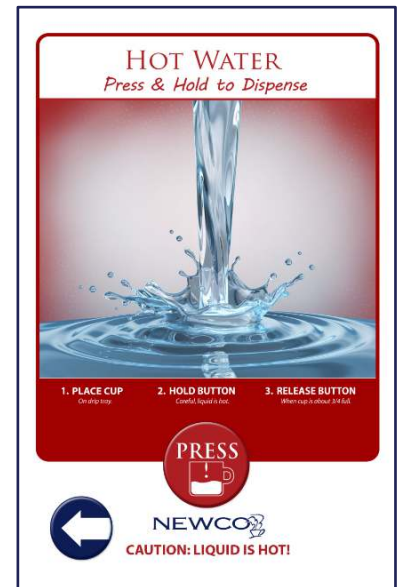

# QR CODE BREWING INSTRUCTIONS

Note: QR Code Brewing is only available when the machine is set to On or Combined Touchless Modes. See page 15 for how to change Touchless Modes.



Touchless Only Mode



Combined Touchless Mode



1. Point your camera, or a QR code reader app, at the QR code on the screen and open the link it shows you.

2. On your phone, choose your beverage type.

3. Adjust beverage size and strength, then press "Next".



4. A QR code will appear on your phone screen, aim your screen at the QR code reader on the machine.



5. Place your cup on the drip tray and aim phone screen at QR code reader again to begin brewing.



6. Enjoy your drink. Note: Brew cycle can be stopped by touching "Cancel".

# SERVICING YOUR MACHINE

## SERVICE NOTES & TROUBLESHOOTING

These error screens will display a service phone number to call if entered in “Setup” Menu.

### FILL TIMEOUT ERROR

Check all water line connections. Check if water line is weak or shut off. If all connections are secure, and water line is good and stable, you may need to replace the Inlet Solenoid Valve (PN [780174](#)), or the Control Board (call your servicer).

**NOTE:** Due to large tank capacity, fill time out error may occur on startup. Please turn machine off, and then back on to clear the error and continue filling.



### THERMISTOR ERRORS

Check thermistor connections. If all connections are secure, replace thermistor (PN [151677](#)).



### HEATER ERROR

Water is not heating up at expected rate- at least 1°F rise in temperature over 4 minutes, or heater has been running continuously for 30 minutes. Check Hi Limit Thermostat (PN [111593](#)), then check heating element (PN [704166](#) for US 1700W or 704161 for Canada 1400 W), lastly check heater relay (PN [110958](#)).



### OVERHEAT ERROR

Temperature in the tank has reached 214°F or higher. Possible relay failure (PN [110958](#)).



### MOTOR ERRORS

Check all wiring connections. Usually repairing a bad connection or replacing the indicated motor will remedy the problem.



If any error reappears shortly after it is believed to be rectified, call your Servicer for further help.

## QR ERRORS

These errors will display briefly, with no Call for Service number. They are only related to QR codes and not the brewer itself.



Invalid QR Code



Drink type not supported



Drink size not enabled

*Note: not supported means the drink recipe is invalid, while not enabled means the recipe is turned off in the Drink Selection Menu of the Setup section in the Programming Menu.*



Invalid size and strength combo



Drink type not enabled



Drink strength not enabled

## OTHER SERVICE SCREENS

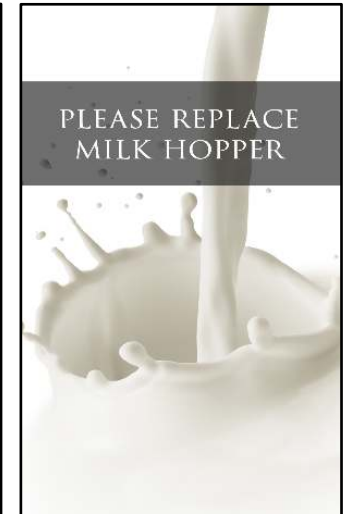
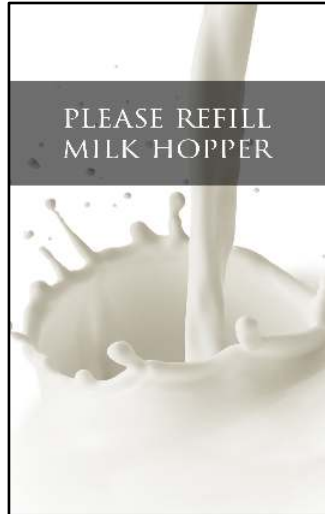
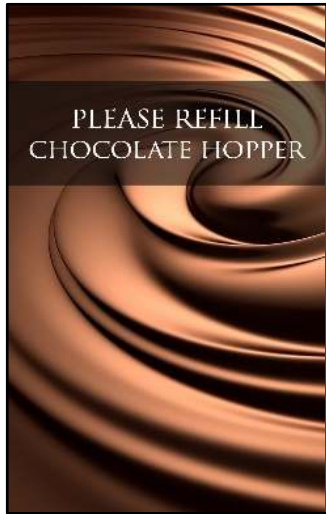

Hopper is empty, remove top cover of machine, then hopper lid. Fill hopper with appropriate powder up to red line. *This screen will only appear if powder tracking is turned on.*

Once hopper is removed to be refilled, the "Please Replace [ ] Hopper" screen will show.

Hopper is not set in place properly, or hopper has been removed. Screen will disappear once hopper is set back in place.

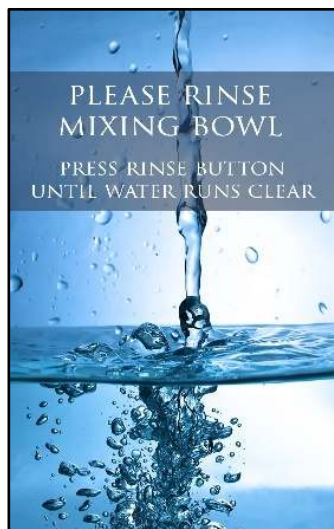

Whipper bowl needs to be rinsed. Press rinse button inside left door, under powder product hoppers. Once water runs clear, release button and screen will disappear.

Waste Bin is full based on Waste Bin Size set in Programming Setup. Screen will change to "Please Replace Waste Bin" once waste bin is removed.

Waste Bin is not set in place or has been removed. Screen will disappear once waste bin is replaced. Note: Waste bin must be removed for more than 5 seconds to reset pod count

## DRAINING THE HOT WATER TANK

Tank holds approximately 1 US gallon.

*Caution-* The water is extremely hot and can cause harmful burns, unless the tank is left to cool. Do not store in freezing conditions as residual water may remain in machine.

### METHOD 1

#### TO DRAIN

1. Unplug machine and remove waste bin. Allow machine to cool before proceeding.
2. Reaching up into the machine from where the waste bin sits, locate the tube clip on the left side of the opening. Follow the tube up to locate the drain tube bracket. See *Image 1*.
3. Push the tubing up to release it from the bracket. You may need to follow the bracket to the right and push up on the tube from the right side to fully release the drain tube.
4. Pull the tubing down and out to the front of the machine.
5. Remove the tube plug using pliers, then aim end of tube to where you are draining the water. Push up on tube clip to open tube. See *Image 2*.

#### TO REPLACE

1. Once the tank is fully drained, tighten the tube clip and insert the drain plug
2. Feed the tube back up into machine, starting from right side of the tubing.
3. Locate the tubing bracket and line tube up with bracket.
4. Using your fingertips, press on the tube and roll it down into the bracket until secure.
5. Ensure tube clip is tucked away on the left side of the tank plate so that it does not interfere with brewing mechanism.

### METHOD 2

#### TO DRAIN

1. Unplug machine and remove waste bin. Allow machine to cool before proceeding.
2. Remove top cover of machine. See page 26.
3. Locate drain tube and drain tube bracket. See *Image 1*.
4. Starting on the left side, pull drain tube up out of the bracket. Once free, feed the drain tube down and out to the front of the machine.
5. Remove the tube plug using pliers, then aim end of tube to where you are draining the water. Push up on tube clip to open tube. See *Image 2*.

#### TO REPLACE

1. Once the tank is fully drained, tighten the tube clip and insert the drain plug.
2. Feed the tube back up to top of machine, starting from right side of the tubing.
3. Line the tubing up with the drain tube bracket, then, starting on the right side, push and roll down to secure tubing into bracket.
4. Ensure tube clip is tucked away on the left side of the tank plate so that it does not interfere with brewing mechanism.
5. Replace top cover of machine.

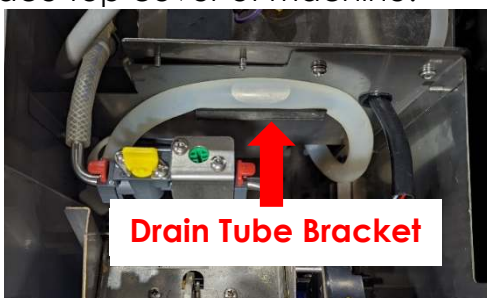

Image 1

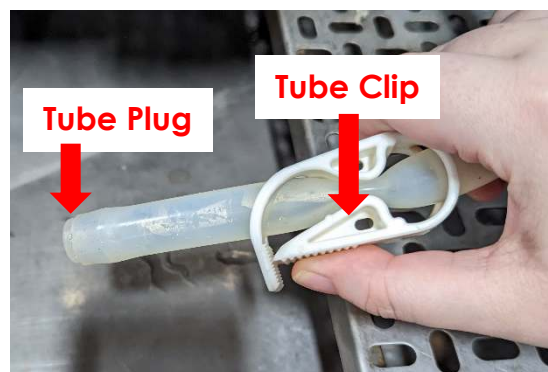

Image 2

# INSIDE YOUR MACHINE

## MACHINE ACCESS POINTS

**CAUTION:** Disconnect power and water from the brewer before servicing.

Note: Top panel must be removed before you can remove rear and side panels.

Screw PN 105096

Current Body Style:



Left and right side panels are mirrored

Legacy Body Style:



## POD BREW MECHANISM REMOVAL

Remove top cover, see page 26 for access points.

**CAUTION:** Disconnect power and water from brewer before servicing.

Front View of underside of dispense area.

Remove two outermost knurled brass nuts (PN 700021), and set aside until reassembly.

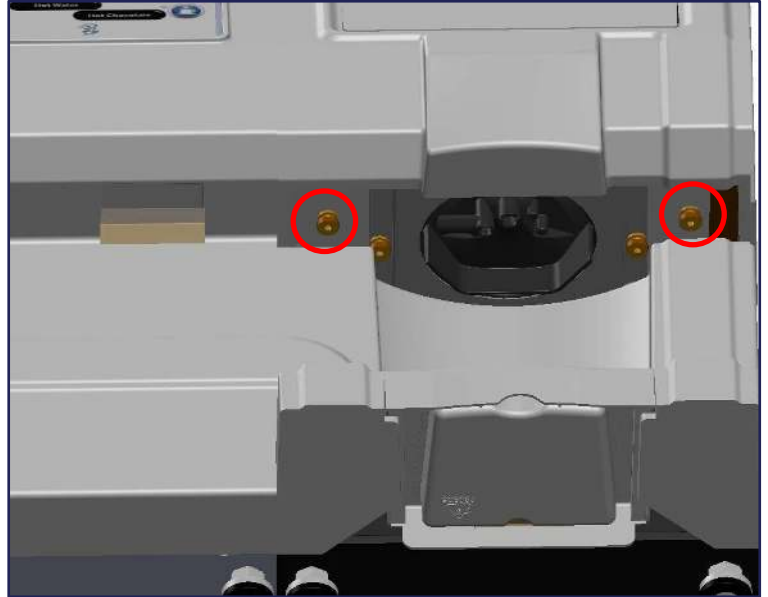

Front View – Top Cover Off

Unsnap water fitting by pushing down on red tab then pulling elbow out.  
 Unsnap wiring harness.  
 Remove drain tube from bracket and move drain tube out of the way.  
 Gently lift brew mechanism up and out of machine.

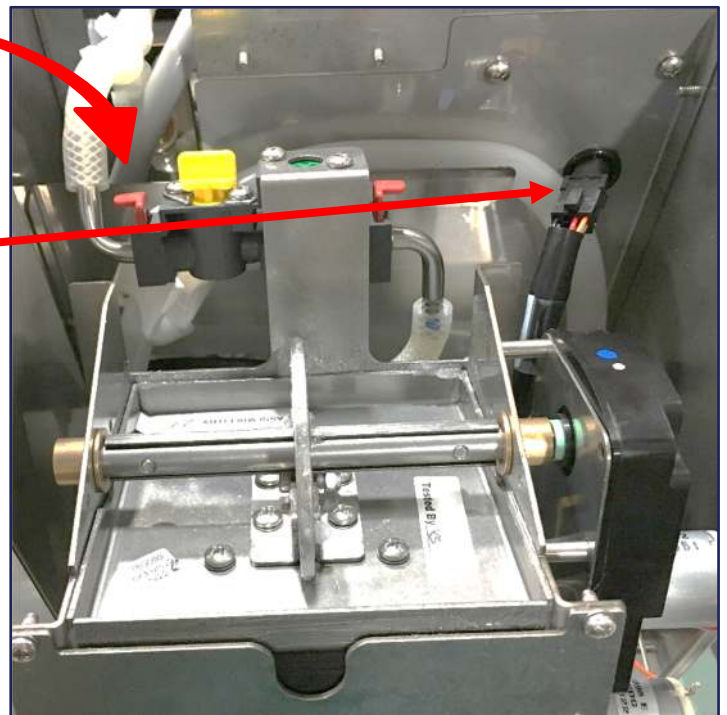

# UNIVERSAL 2 POD BREW MECH ASSEMBLY PN 780099

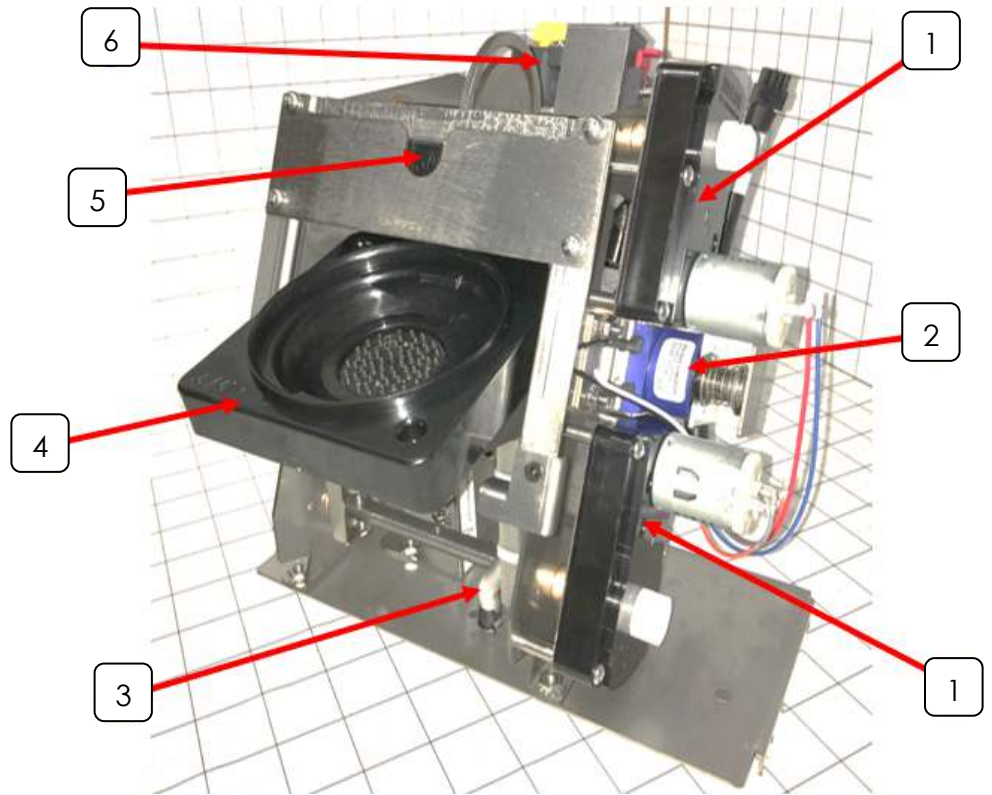

Picture taken on 1 inch grid

ITEM	PART NUMBER	DESCRIPTION	QTY
1	780230	BREW MECH MOTOR	2
2	780476	DELTROL SOLENOID ASSEMBLY	1
3	780368 & 780320	BREW HOSE WITH PROTECTIVE SPRING	1
4	780871	LOWER BREW CHAMBER UNIVERSAL 2 ASSEMBLY	1
		6-32 SCREWS	
		O RING	
		1/4" X 1" STANDOFF SPACER	
		COMPRESSION SPRING	
		CUP WASHER	
		DISC ASSY, MOLD, 13 HOLE	
		MOLDED BUMP DISC PAD	
		LOWER BREW CHAMBER	
5	780775	UPPER BREW CHAMBER ASSEMBLY	1
		U-CUP SEAL	
		UPPER BREW CHAMBER	
6	320043	VALVE WITH SHUTOFF	1

Newco has many replacement kits available

NOTE: Your CX Machine can be equipped with various optional brew mechanisms to provide brewing choices tailored to your specific needs. For information on these optional brew mechanisms and associated replacement parts contact NEWCO Technical Services at 1-800-556-3926 or NEWCO Customer Service at 1-800-325-7867

# WHIPPER ASSEMBLY PN 767377

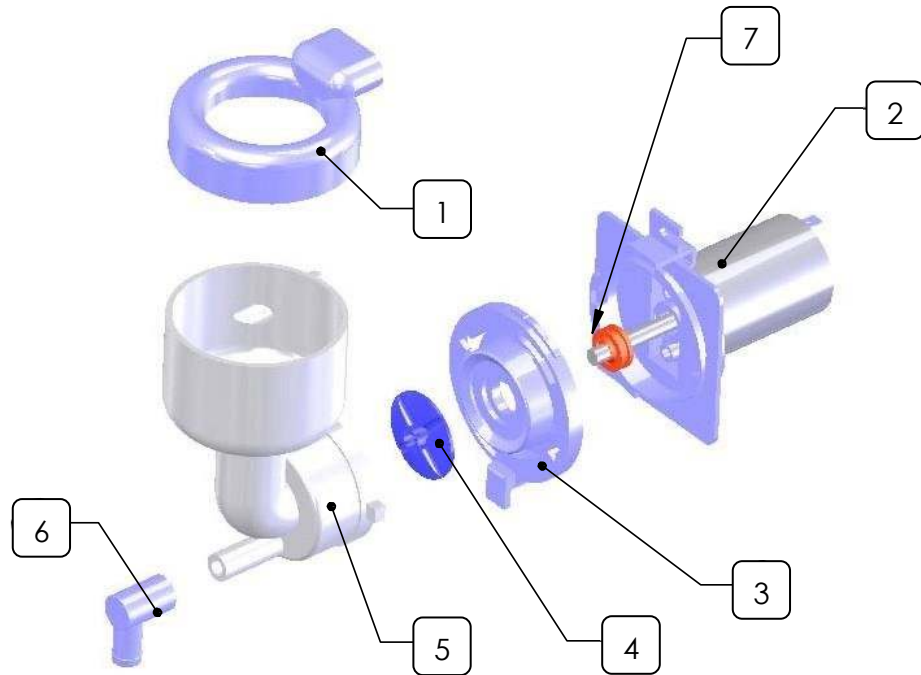

ITEM	PART NUMBER	DESCRIPTION	QTY
1	767376	WHIPPER STEAM CAP	1
2	767195	WHIPPER MOTOR	1
3	767196	WHIPPER MOUNTING BASE	1
	767390	WHIPPER O RING	1
4	767197	WHIPPER IMPELLER	1
5	767365	WHIPPER BOWL	1
6	767200	WHIPPER NOZZLE	1
7	781566	WHIPPER SEAL -Replace after 5000 cycles	1

# WHIPPER & HOPPER ASSEMBLY

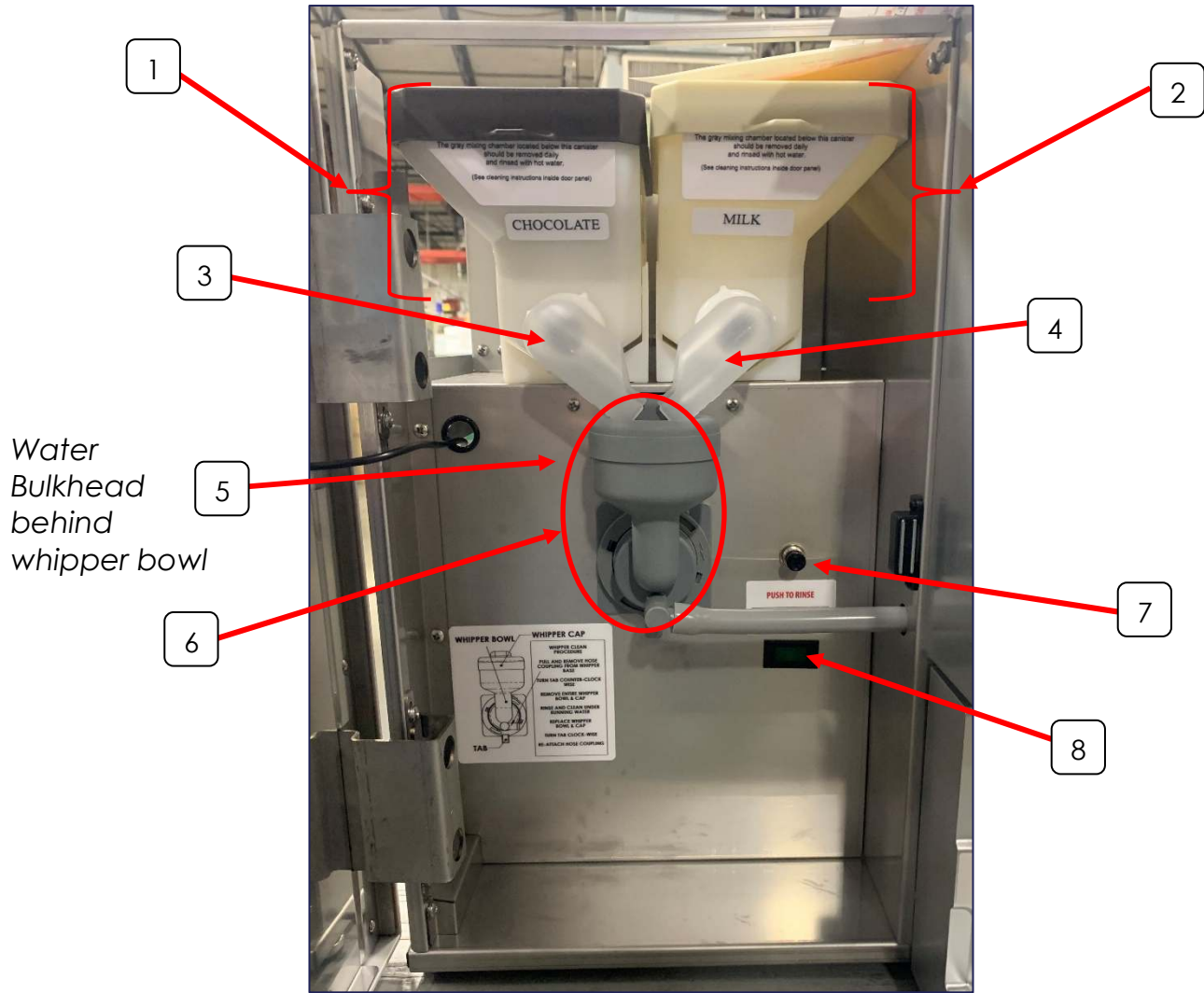

ITEM	PART NUMBER	DESCRIPTION	QTY
1	780197	HOPPER ASSEMBLY, LEFT HAND (CHOCOLATE)	1
	780153	HOPPER LID- BROWN	1
2	780196	HOPPER ASSEMBLY, RIGHT HAND (LATTE/MILK)	1
	780154	HOPPER LID- WHITE	1
3	767201	7cm ELBOW, LEFT HAND	1
4	767202	7cm ELBOW, RIGHT HAND	1
5	781040	WATER BULKHEAD	1
6	767377	WHIPPER ASSEMBLY	1
7	100343	RINSE BUTTON	1
8	702062	POWER INDICATOR LIGHT	1

**TANK ASSEMBLY  
PN 783332 (ROUND TANK)**

**ALTERNATE PN 783384 (SQUARE TANK)**

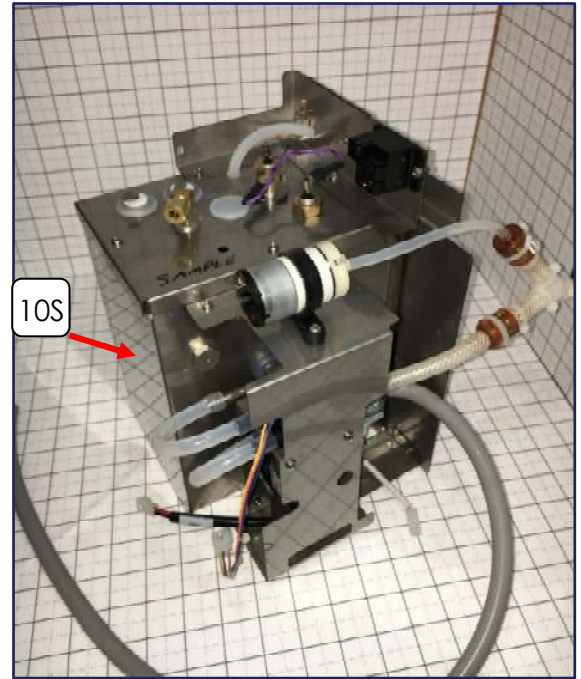
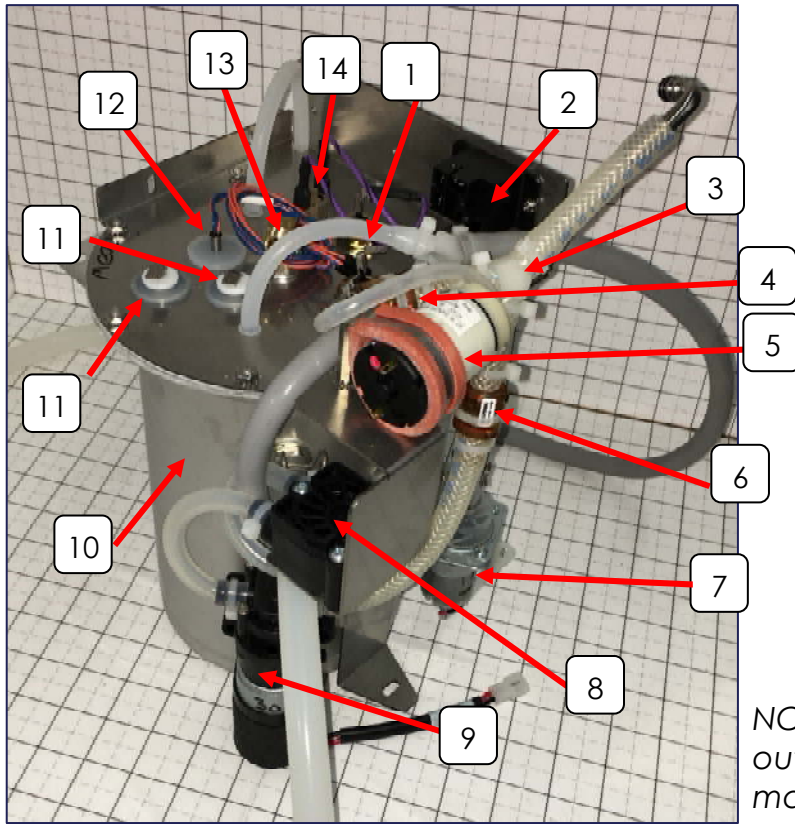

NOTE: Due to large tank capacity, fill time out error may occur on startup. Please turn machine off, and then back on to clear the error and continue filling.

ITEM	PART NUMBER	DESCRIPTION	QTY
1	704166 (1700W)	TANK HEATING ELEMENT (US)	1
	704161 (1400W)	TANK HEATING ELEMENT (CAN)	1
2	110958	RELAY, 12 V DC SPST 30A	1
3	767281	"Y" HOSE FITTING	1
	780090	AIR PUMP KIT	1
4	773056	AIR PUMP	
5	202165	CHECK VALVE ASSEMBLY	
6	202178	WATER PUMP CHECK VALVE	1
7	781772	PUMP ASSEMBLY WITH ELBOW (HOT WATER)	1
8	780684-10	DEFOND FLOWMETER	1
9	109937	GEAR PUMP ASSEMBLY	1
10	780218	PUNCHED TANK (ROUND)	1
	783333	TANK LID (ROUND)	
	704221	TANK GASKET (ROUND TANK)	
10S	783373	WELDED TANK (SQUARE)	1
	783377	TANK LID (SQUARE)	
	119882	TANK GASKET (SQUARE TANK)	
11	500384	PROBE KIT 1.818"	2
12	151677	DUAL TEMP THERM PROBE	1
13	100149	ELBOW ¼ C×⅛ NPT	1
14	111593	HI-LIMIT THERMOSTAT	1

# FRONT PANEL ASSEMBLY PN 782318

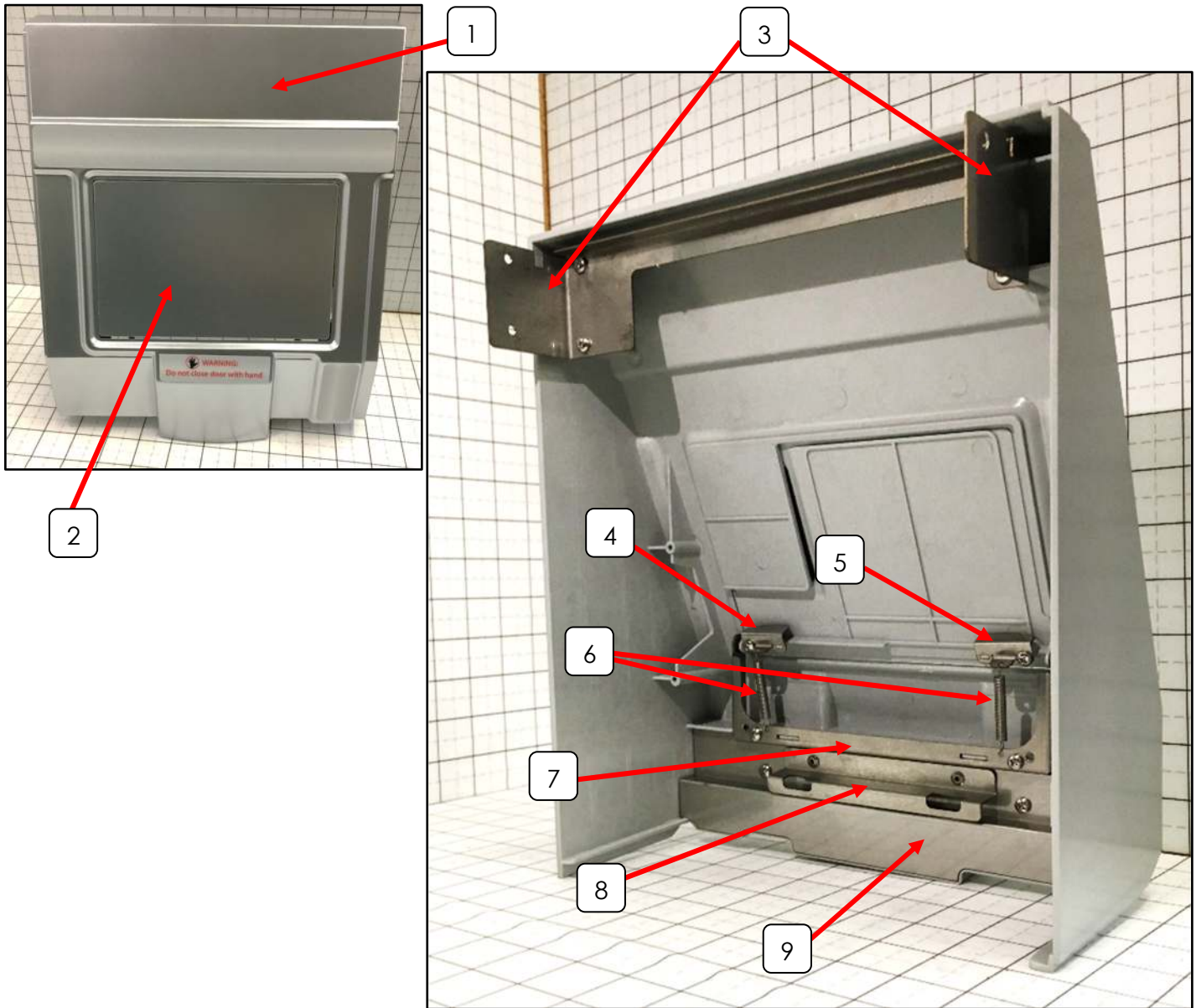

ITEM	PART NUMBER	DESCRIPTION	QTY
1	780802 -SV	PANEL, MAIN FRONT, SILVER	1
2	780803 -SV	DOOR, SMALL FRONT, SILVER	1
3	783311	BRACKET, BREW DOOR MOUNT	1
4	780046	BRACKET, DOOR SPRING LEFT	1
5	780047	BRACKET, DOOR SPRING RIGHT	1
6	780061	SPRING, DOOR ASSEMBLY	2
7	780044	HINGE BRACKET, BREW DOOR	1
8	780040	BREWER, RETAINER	1
9	780045	COVER, LOWER BACK, FRONT PANEL	1

Picture taken on 1 inch grid

# DOOR ASSEMBLY PN 783335

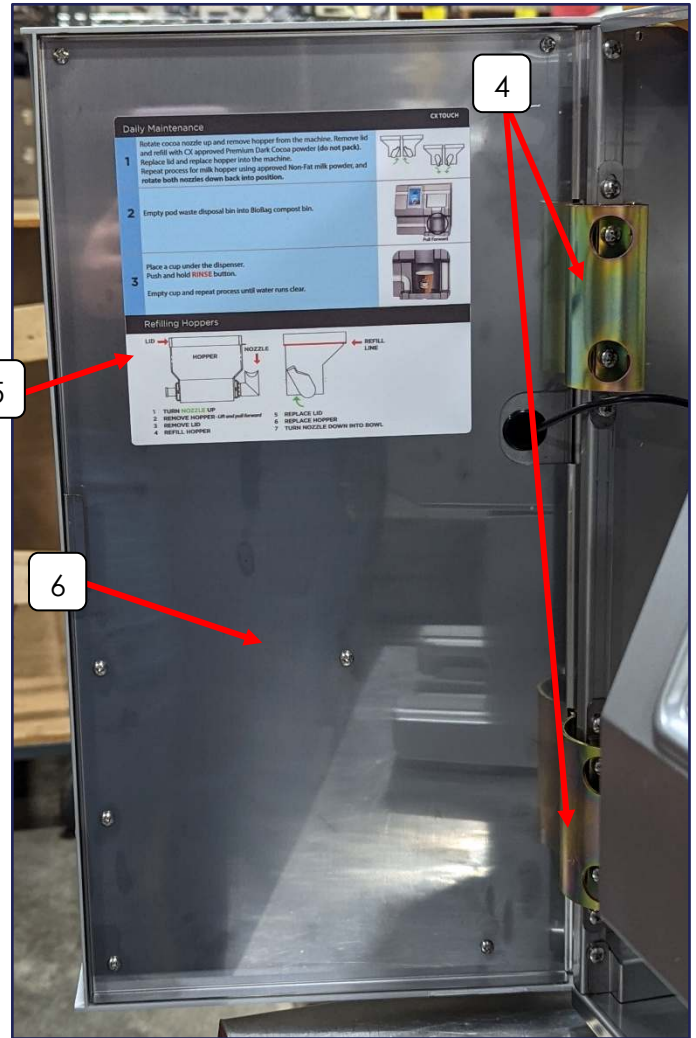
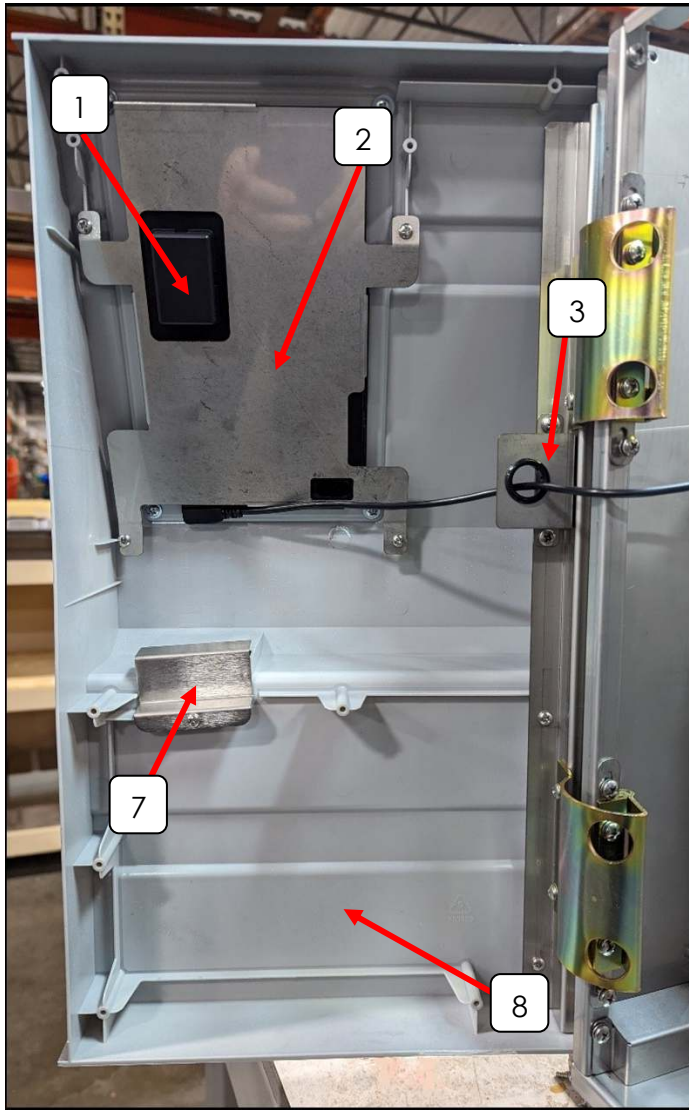

ITEM	PART NUMBER	DESCRIPTION	QTY
1	783337	7" TABLET	1
2	783339	RETAINER, 7" TABLET	1
3	783315	BRACKET, POWDER DOOR GROMMET	1
4	102071	HINGE, INNER DOOR	2
5	782297	LABEL- CX TOUCH DAILY MAINTENANCE	1
6	783314	PANEL, INNER DOOR	1
7	780020	COVER, DOOR HANDLE	1
8	780809 -SV	DOOR, SIDECAR, SILVER	1

# WIRING DIAGRAM

Wire colors subject to change based on availability

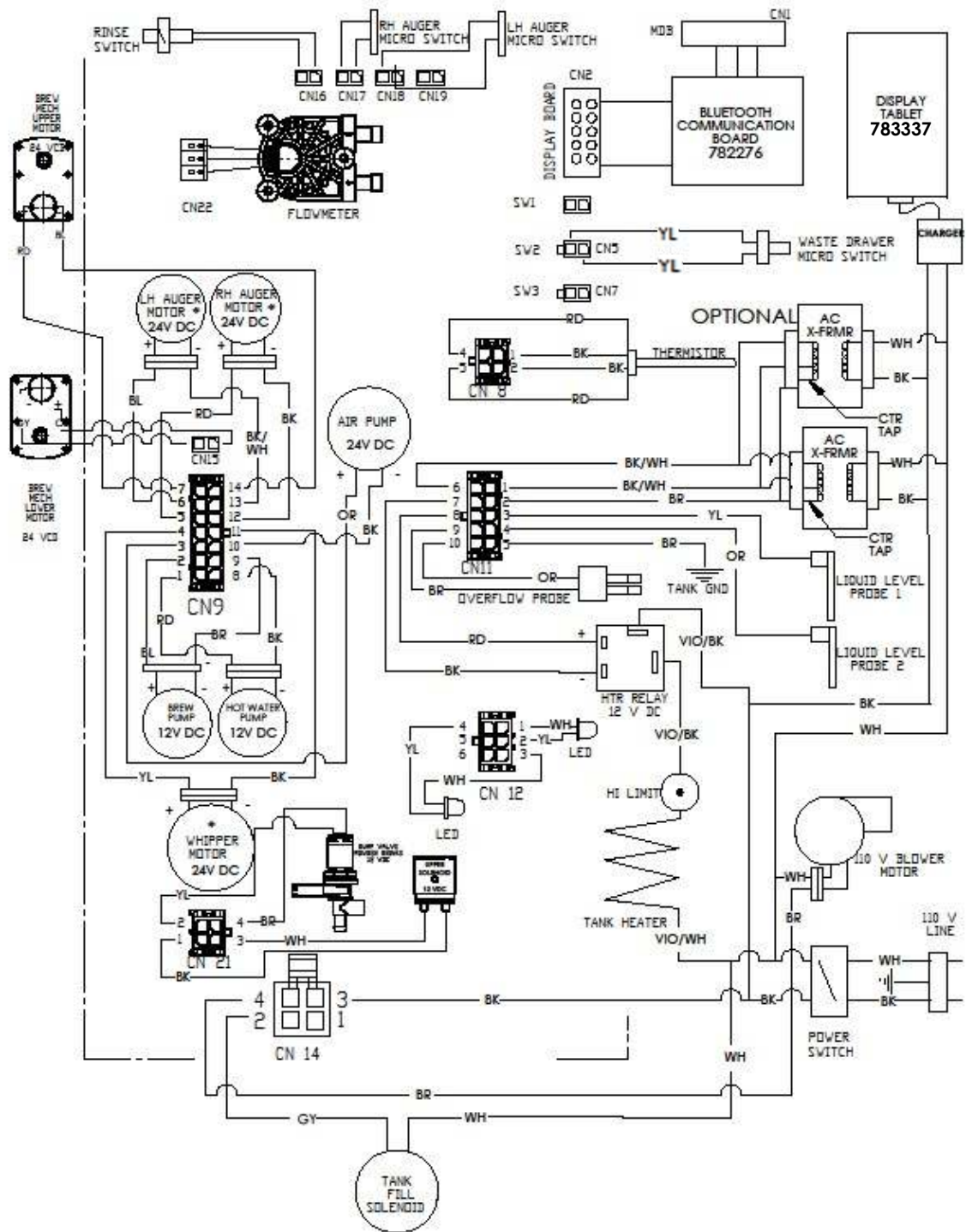

**782277** Control Board Assembly 8, 10, 12 oz drinks (Special Order only)

**782306** Control Board Assembly 7, 8, 9 oz drinks

***Page intentionally left blank***