

# SINGLE SERVING AUTOMATIC POD MACHINE FRESH CUP TOUCH

NEWCO ENTERPRISES INC,  
3650 NEW TOWN BLVD SAINT CHARLES, MO 63301  
1-800-325-7867



## FEATURES/ SPECIFICATIONS

- AUTOMATIC POD REMOVAL
- TOUCHSCREEN OPERATION
- FLOWMETER
- UP TO 20 OZ TRAVEL MUG
- LARGE POD WASTE TRAY / PASS THROUGH OPTION
- ADJUSTABLE DRINK STRENGTH
- ADJUSTABLE DRINK VOLUME
- USB INTERFACE
- 1 GALLON TANK CAPACITY

For Brewer PN 782150

# NEWCO CONTACT INFORMATION

## ADDRESS

NEWCO ENTERPRISES INC,  
3650 NEW TOWN BLVD SAINT CHARLES, MO 63301

## CUSTOMER SERVICE PHONE

1-800-325-7867

## TECHNICAL SERVICE PHONE

1-800-556-3926

## FAX

1-636-925-0029

## WEBSITE

[newcocooffee.com](http://newcocooffee.com)

## CUSTOMER SERVICE AND SALES EMAIL

[sales@newcocooffee.com](mailto:sales@newcocooffee.com)

## MAINTENANCE INFORMATION

Machine Model \_\_\_\_\_

Service Company Information

\_\_\_\_\_  
\_\_\_\_\_  
\_\_\_\_\_

# TABLE OF CONTENTS

**NEWCO PRODUCT WARRANTY** -----4

**SPECIFICATIONS** -----5

**MACHINE SET-UP** -----7

**MACHINE PROGRAMMING** -----8

**MACHINE OPERATION** -----18

**USB INTERFACE** -----20

**SERVICING THE MACHINE**

    SIDE PANEL REMOVAL -----24

    REMOVING THE BREW MECHANISM -----25

    DRAINING THE HOT WATER TANK -----26

    TANK REMOVAL & ACCESS AREAS -----27

    ERROR MESSAGES -----28

**INSIDE YOUR MACHINE**

    POD BREWING MECHANISM -----29

    TANK ASSEMBLY -----30

    FRONT PANEL -----31

    ELECTRICAL COMPONENTS -----32

    WIRING DIAGRAM -----33

# WARRANTY

*This warranty supersedes all other previous warranties that are currently in manuals. Newco warrants equipment manufactured by it for 1 year parts and labor. Accessories, Dispensers, and Display Tablets - 1 Year parts only. Electronic Circuit and Control Boards- 3 years parts, 1 year labor. Equipment manufactured by others and distributed by Newco- please see original equipment manufacturers warranty, Newco will follow.*

These warranty periods run from the date of sale Newco warrants that the equipment manufactured by it will be commercially free of defects in material and workmanship existing at the time of manufacture and appearing within the applicable warranty period. This warranty does not apply to any equipment, component or part that was not manufactured by Newco or that, in Newco's judgment, has been affected by misuse, neglect, alteration, improper installation or operation, relocation or reinstallation, improper maintenance or repair, incorrect voltage applied to the unit at any time, damage or casualty. This warranty does not apply to any equipment failures related to poor water quality, excessive lime and chlorine and non-periodic cleaning and descaling. Warranty is null and void if muriatic or any other form of hydrochloric acid is used for cleaning or deliming. In addition, this warranty does not apply to replacement of items subject to normal use including but not limited to user replaceable parts such as faucet seat cups, sight gauge tubes, washers, o-rings, tubing, seals and gaskets.

This warranty is conditioned on the Buyer 1) giving Newco prompt notice of any claim to be made under this warranty by telephone at (800) 556-3926 or by writing to **3650 New Town Blvd, Saint Charles, MO 63301**; 2) if requested by Newco, shipping the defective equipment prepaid to an authorized Newco service location; and 3) receiving prior authorization from Newco that the defective equipment is under warranty.

THE FOREGOING WARRANTY IS EXCLUSIVE AND IS IN LIEU OF ANY OTHER WARRANTY, WRITTEN OR ORAL, EXPRESS OR IMPLIED, INCLUDING, BUT NOT LIMITED TO, ANY IMPLIED WARRANTY OF EITHER MERCHANTABILITY OR FITNESS FOR A PARTICULAR PURPOSE. The agents, dealers or employees of Newco are not authorized to make modifications to this warranty or to make additional warranties that are binding on Newco. Accordingly, statements by such individuals, whether oral or written, do not constitute warranties and should not be relied upon.

If Newco determines in its sole discretion that the equipment does not conform to the warranty, Newco, at its exclusive option while the equipment is under warranty, shall either 1) provide at no charge replacement parts and/or labor (during the applicable parts and labor warranty periods specified above) to repair the defective components, provided that this repair is done by a Newco Authorized Service Representative; or 2) shall replace the equipment or refund the purchase price for the equipment.

THE BUYER'S REMEDY AGAINST NEWCO FOR THE BREACH OF ANY OBLIGATION ARISING OUT OF THE SALE OF THIS EQUIPMENT, WHETHER DERIVED FROM WARRANTY OR OTHERWISE, SHALL BE LIMITED, AT NEWCO'S SOLE OPTION AS SPECIFIED HEREIN, TO REPAIR, REPLACEMENT OR REFUND.

In no event shall Newco be liable for any other damage or loss, including, but not limited to, lost profits, lost sales, loss of use of equipment, claims of Buyer's customers, cost of capital, cost of down time, cost of substitute equipment, facilities or services, or any other special, incidental or consequential damages.

**WARNING: Read and follow installation instructions before plugging or wiring in machine to electrical circuit. Warranty will be void if machine is connected to any voltage other than that specified on the serial tag. Machine must be plugged into a grounded outlet.**

# SPECIFICATIONS

## TANK WATTAGES

US 1700 W 120V

CANADA 1400 W 120V

## TANK CAPACITY

1 US GALLON

## TRAY CAPACITY

8 OUNCES

## POD WASTE TRAY CAPACITY

50 PODS\*

UP TO 20 OZ CUP SIZE

## SHIPPING WT

APPROX 35 LBS

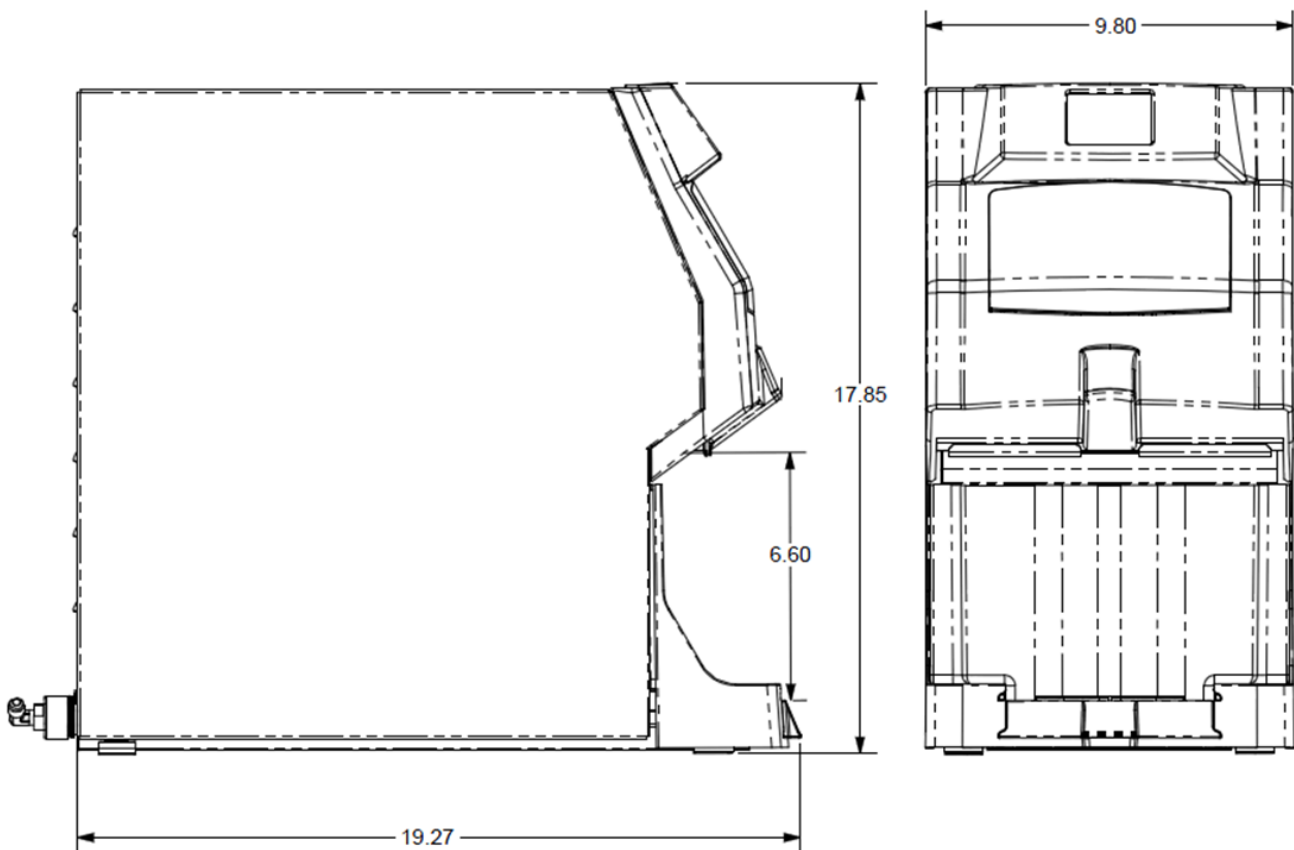

*\*Depending on pod size*

# USE WASTE TRAY PN 782183 FOR PASS THROUGH USE

Rear of machine

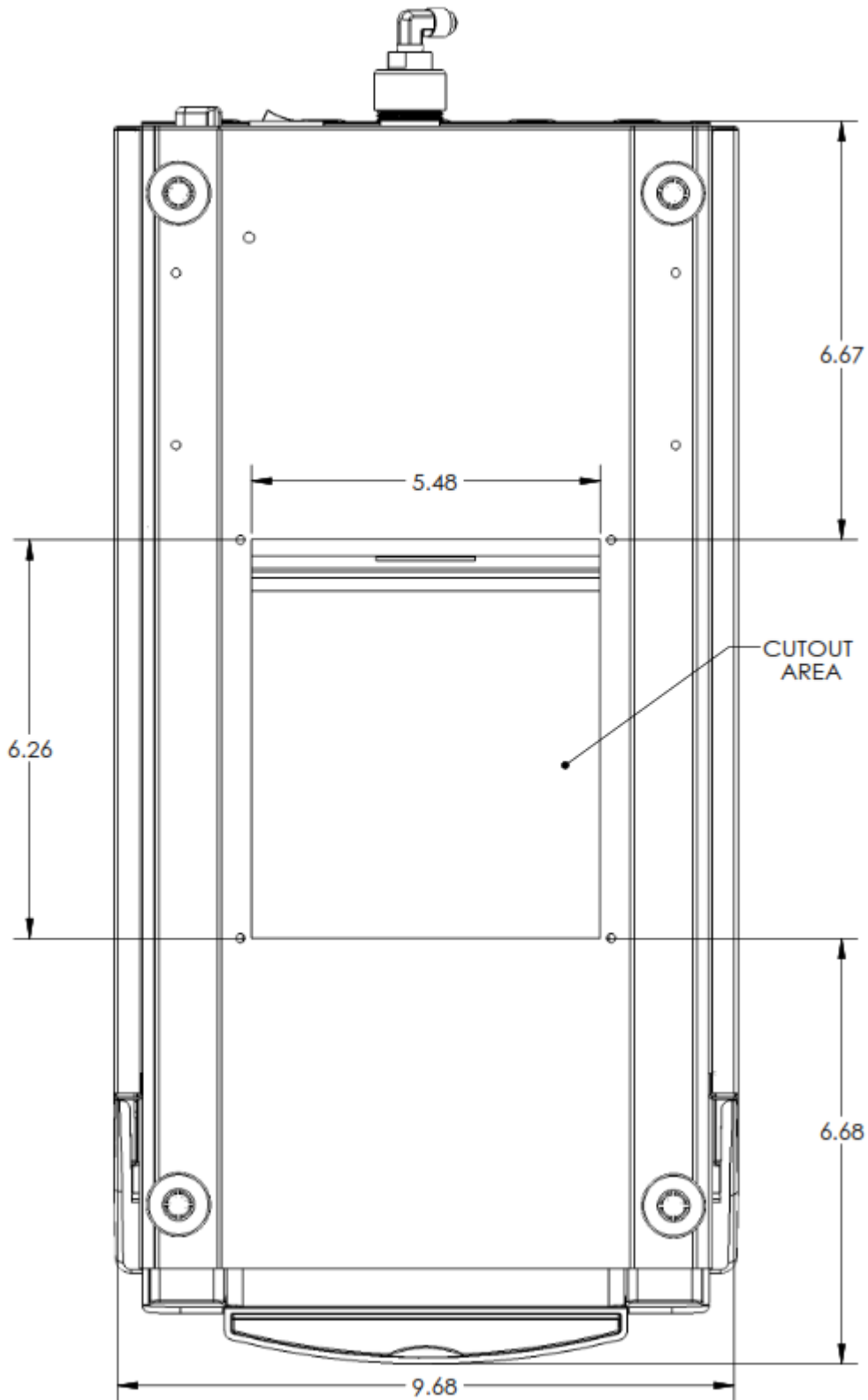

Front of machine

# MACHINE SET-UP

*NOTE: The FRESH CUP machine weighs approximately 35 LBS. Use CAUTION when unpacking and lifting machine. LIFT MACHINE FROM MACHINE BOTTOM ONLY. DO NOT MOVE MACHINE UNLESS THE HOT WATER TANK IS DRAINED AND EMPTY.*

## PLUMBER'S INSTALLATION INSTRUCTIONS

1. Brewer must be installed to comply with all applicable federal, state, and local plumbing codes and ordinances.
2. Plumb brewer into the water supply using ¼ inch copper tubing. Flush water line before installing brewer to remove sediment. Brewer should be connected to COLD WATER LINE for best operation. Water line must supply a minimum of ½ GPM.
3. Water pressure should be at least 20 lbs. For less than a 25 ft. run, use ¼" tubing and connect to ½" or larger water line. The inlet water fitting on the back of the brewer is a ¼" flare fitting.
4. If installed with saddle valve, the valve should have a minimum of ⅛" porthole for up to 25 ft. run, and ⅝" porthole for over 25 ft. runs.
5. Turn on water supply and check for leaks.

## INITIAL SET UP

1. Open and install the grill into the drip tray. Place drip tray into waste bin.
2. Connect water fitting with strainer on the rear of machine next to the power switch.
3. Ensure the power switch to the off position ("O") and plug the machine into a properly installed and grounded electrical circuit.
4. Turn the power switch to the on position ("I") to start the initial water fill cycle.

**WARNING:** *Read and follow installation instructions before plugging or wiring in machine to electrical circuit. Warranty will be void if machine is connected to any voltage other than that specified on the serial tag. Machine must be plugged into a grounded outlet.*

## STARTUP AND USAGE

This will be displayed momentarily, and indicates the hardware and software revision levels.



This will be displayed on the initial filling of the hot water tank until water level reaches the liquid level probe.

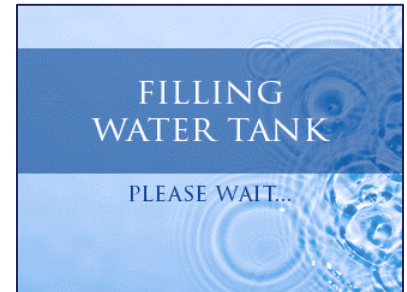

When the hot water tank is filled, then heater circuit will turn on. Allow up to 10 min for the tank to reach brewing temperature. This will be displayed while the hot water tank is heating.



When the hot water tank temperature reaches its set point, the selection screen will be displayed. Your machine is now ready for programming or operation.



## BREW OPERATION

1. Place cup under brew nozzle on drip tray.
2. Select coffee, tea, or espresso.
3. Unwrap the pod & place flat side up in center of brew chamber. *Do not pinch your pod.*
4. Make selections and press the brew button-drawer will close & brew cycle will start.
5. Once the pod drying cycle is complete, the pod will eject in the waste bin & the cup can be removed.

# MACHINE PROGRAMMING

## PROGRAM SETTINGS

To enter the programming settings, press and hold the upper right-hand corner of the touch screen when powering up the machine. The Fresh Cup pod brewer has a programming menu that consists of eight icons, which are selected by touch.

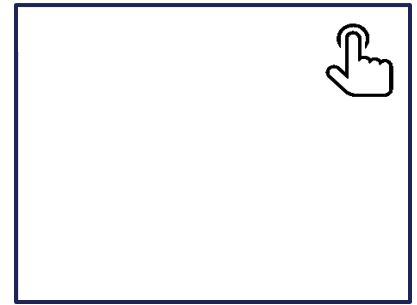

The current entries in the Programming Settings Menu are as follows:

- **TEMPERATURE**
- **RECIPES**
- **ENERGY SAVE**
- **WASTE BIN**
- **WATER FILTER**
- **FLOW ADJUSTMENT**
- **BUZZER VOLUME**
- **EXIT**

**RECIPES**  
Allows programming of parameters unique to each recipe.

**ENERGY SAVE**  
Reduces temperature set-point after pre-set time has expired.

**TEMPERATURE**  
Allows programming of tank set-point temperature.

**WASTE BIN**  
Set Pod count before signaling bin is full.

**EXIT**  
Exits the programming menu.

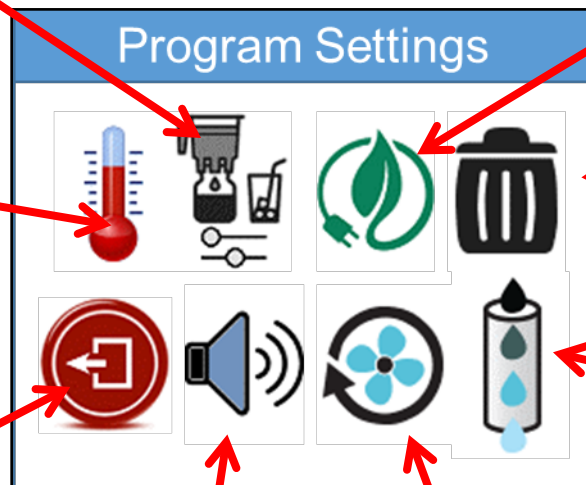

**WATER FILTER**  
Allows user to select filter size if installed on machine.

**BUZZER VOLUME**  
Allows user to set the buzzer volume.

**FLOW ADJUSTMENT**  
Allows user to adjust dispensed volume calibration.

Pressing the green (+) and (-) buttons will change the set point, incrementing or decrementing by one. Pressing the Blue "Back" button will exit.

## SET TEMPERATURE

In this entry the user may set the tank temperature in the range of 180°F to 203°F with the default at 200°F.

High elevations- at 5000 ft, you should set the temperature to 192°-195°F (88.9°-90.6°C)

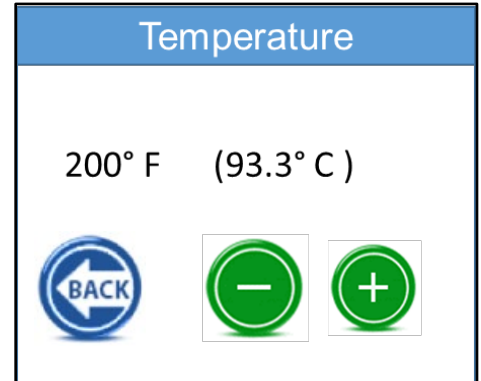

## SET ENERGY SAVE MODE

This screen allows the user to select from three different energy save modes to conserve energy during periods of non-use. This screen also allows the user to set the time the machine will maintain temperature until the energy save function is activated.

### OFF MODE (DEFAULT)

No Energy Save, power on.

### ENERGY SAVE

Partial Energy Save Mode. After the user selected Idle Time is reached, the tank temperature set point is reduced to 180°F until a any interaction is detected.

### FULL ENERGY SAVE

Full Energy Save Mode. After the user selected Idle Time is reached, the tank heater is disabled until any interaction is detected.

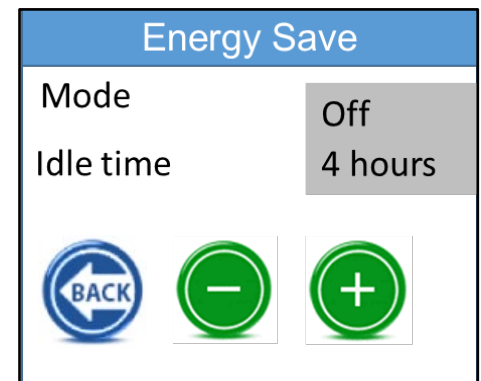

## SET IDLE TIME

The user can choose 1 through 4 hours in 1-hour increments with the default set to 4 hours.

*Note: after 72 hours of non-use, the heater will turn off. Any interaction will turn the heater back on.*

## SET BUZZER VOLUME

The range is from 0 to 100. The default is 20. You will hear this any time a button is pressed.

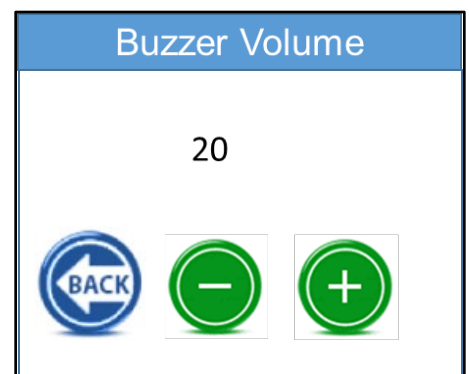

## SET POD COUNT

In this entry the user may set the number of pods the brewer will hold before signaling that the bin is full. The range is 10 to 100 pods, with the default at 50. This can be turned off, if you are using a special ordered pass through brewer. Standard waste bin capacity is 50 pods.

*It is recommended that you empty and rinse the waste bin every day.*

### RESET TIME

This is the time the waste bin must be out of its place for the pod count to reset.

### REMOVE WASTE BIN

Gently pull on the sides of the silver base where the drip tray rests. Please note that the drip tray itself can be removed and has two different height slots.

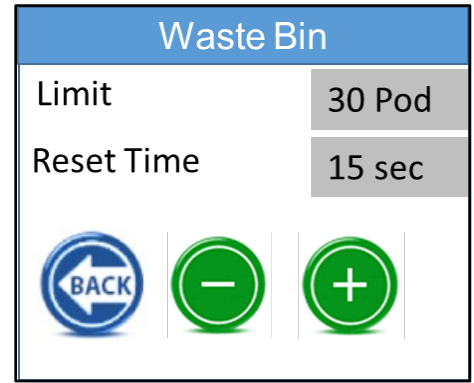

## WATER FILTER

The default setting is "OFF". If you are installing a purchased water filter, then set this to match the size of the filter. This machine can accommodate a filter size range of 500 gallons to 3000 gallons. This sets the counter for the filter warning. When ever water is dispensed, the counter is incremented to account for the water dispensed. When the counter is above 90% of the capacity of the chosen filter a warning message will display on the screen. If the filter selection is "OFF" then following entries are not available.

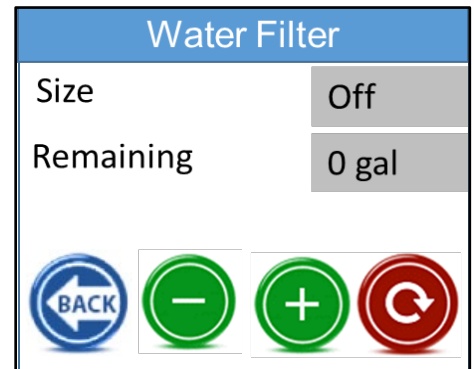

## GALLONS REMAINING

This entry scrolls the number of gallons left before the filter should be replaced.

### RESET FILTER

Press and hold the Reset Button, a timer will count down to reset the counter.



## FLOWMETER ADJUSTMENT

Each increment of this setting adjusts the volume of liquid dispensed by 0.2 oz. This can be used to fine-tune the amount of liquid that is dispensed.

*Note: This setting will adjust all recipe volumes to provide precise accuracy.*

## THESE MACHINES ARE EQUIPPED WITH A FLOWMETER

Please run your Fresh Cup pod brewer a few times. Ensure volume dispensed is consistent, so that no further calibration is needed. Please note that running cycles without a pod will yield in approximately ¼ oz more than programmed dispense volume.

The flow adjustment is likely to be around +3 when coming from the factory. If this needs to be adjusted over time, then there could be an issue with hardwater buildup, or possibly a component failure- most likely the pump, or the flowmeter in this case.

*This setting is only to fine tune dispensed volume. Please refer to Recipe Settings to change the amount in ounces for each cup size.*

NOTE: The machine has been calibrated at the factory and has been adjusted to brew into an 8 ounce cup with approximately 7 ounces of coffee for brew strengths of mild, medium, and bold.

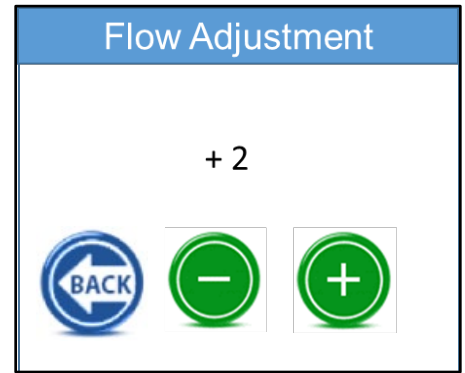

## RECIPE SETTINGS

This screen takes the user into a sub menu to program the parameters unique to each recipe.

See next page for detailed description on how to change Recipe Parameters.

As with most of the entries, pressing the green (+) and (-) buttons will change the entry then press the blue "Back" button to exit.



## SET BREW VOLUME

This entry sets the volume in ounces for this recipe to dispense. The range is from 2.0 to 16.0 ounces with the default set to 7 ounces for small, 8 ounces for medium, and 9 ounces for large, with the exception of the Iced and Espresso recipes. It is recommended to have 7 ounces of water per 10 grams of coffee grounds. Please take note of what size pod you are using.

## SET PRE-INFUSION VOLUME

This entry sets the volume in ounces for the first pulse of water. Range is 0.0 to 3.0.

## SET BREW PUMP SPEED

In this entry the user may set the dc pump strength in the range of 10% to 100% with the default at 35%.

*Note: A high pump speed can negatively affect extraction and can be noisy. It is not recommended to change this setting.*

## SET BREW PULSE TIME

The pulse time displayed is the duration of pauses, or "off" pulses, during the brew cycle. Increasing or decreasing the pulse time will increase or decrease the overall water contact time with the pod, resulting in a stronger or weaker strength of brew. The range is from 0 to 30 seconds, with the default set at 16 seconds for a 7 ounce cup.

## SET AIR PUMP SPEED

In this entry the user may set the air pump strength in the range of 30% to 100% with the default at 80%. Please note that too high of a speed can result in a broken coffee pod.

## SET AIR PUMP TIME

In this entry the user may set the air pump time in the range of 2 to 15 seconds with the default at 10. This will drain the remaining brew into the holding container.

*Please note that we take our time to develop the default recipe parameters.*

## BACK

Exit to Main Programming Menu.

## RECIPE GUIDE

To make a setting selection, touch either the icon, wording, or grey box.

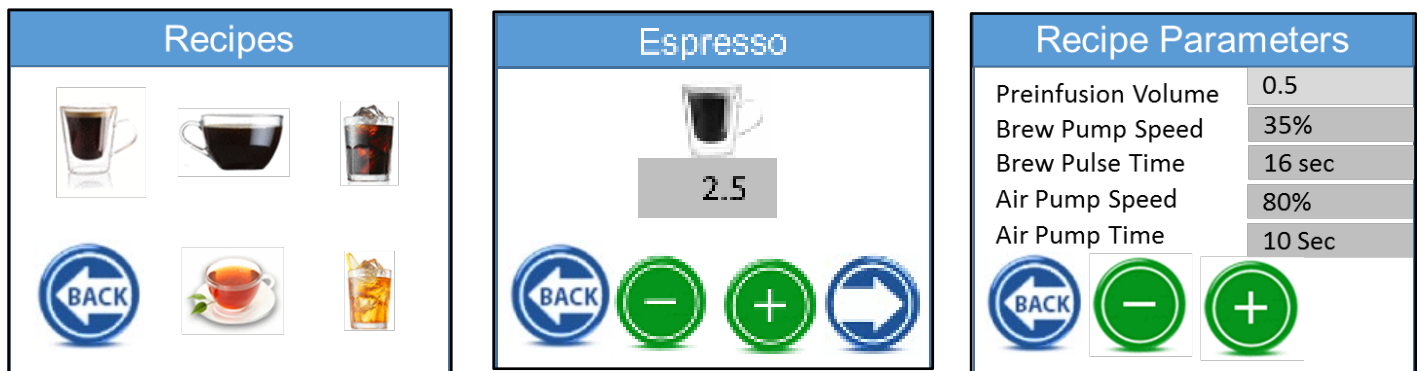
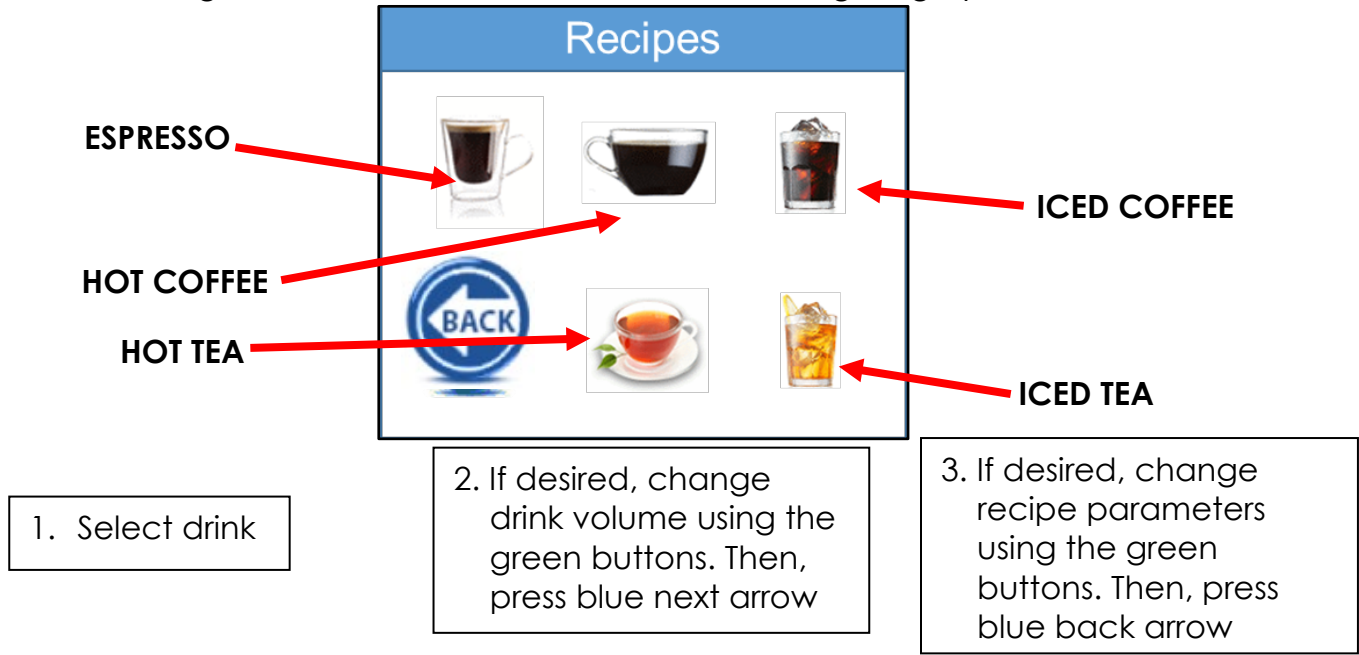

Note: For recipes other than Espresso, drink size and strength must be selected before access to recipe parameters will be allowed.

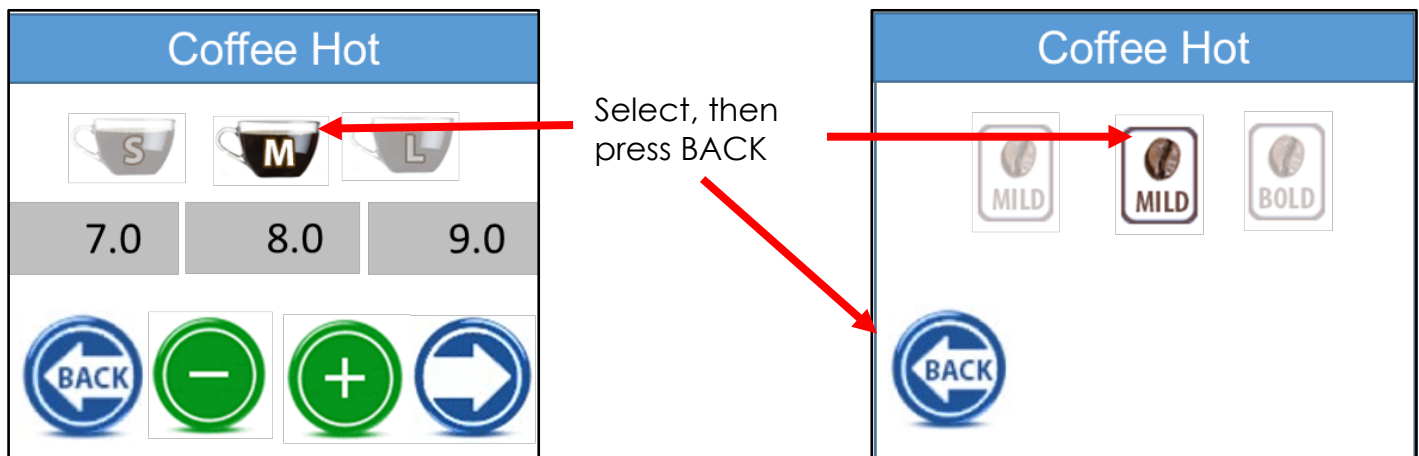

## EXIT MENU

Exit to Ready to Brew Mode and save parameters.

# FACTORY PROGRAMMING SETTINGS

This menu is accessed by holding the lower right corner of the touchscreen when powering up the machine. Continue to hold until the Factory Programming Menu Appears



**FLOWMETER TEST**  
Flow Meter  
Diagnostic Test

**DRAIN WATER LINES**  
Remove Excess  
Water in lines prior to  
Moving machine  
menu

**MACHINE  
OPTIONS**  
See Machine  
Options Menu  
below

**FACTORY RESET**  
Resets Machine  
to Factory  
Defaults

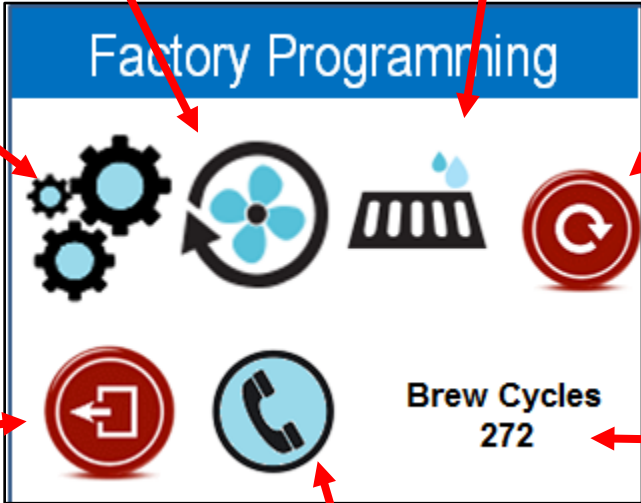

**EXIT**  
Exits the  
Factory  
Programming  
Menu

**MACHINE CYCLE  
COUNT**  
Non-resettable  
Cycle Count  
Display

**CALL FOR SERVICE**  
Allows entry of a  
Call for Service  
Phone Number

## MACHINE OPTIONS

This Menu determines which items are displayed on the Main Program Menus. Green buttons indicates that the selection is active, grey buttons are inactive. To make a setting selection, touch either the wording or the green box.

The screenshot shows the 'Machine Options' menu with the following items and callout boxes:

- CUP SIZE SELECTION:** Toggles which cup sizes appear on the Drink Selection Menu Screen. (Points to Small, Medium, Large, Slates)
- SLATES SELECTION:** Determines whether Cartoon Slates or the Logo Screen appear during any coffee based brew cycle. Deselecting cancels Slates and enables the Logo Screen. Tea brew cycles will always display the logo. (Points to Slates)
- DRINK STRENGTH SELECTION:** Toggles which Strength Selections appear on the Drink Selection Menu Screen. (Points to Mild, Med, Bold)
- DRINK TYPE SELECTION:** Toggles which Drink Types appear on the Drink Selection Menu Screen. (Points to Hot Tea, Iced Tea, Iced Coffee, Espresso)
- EXIT:** Exits the Machine Options Menu. (Points to the BACK button)

*Note: The Cup size and Drink Strength Selections are Global. The selections affect all drink types.*

For both Flowmeter Test and the Drain Water Lines, make sure there is a container in place to catch the water.

## FLOWMETER TEST

This is a diagnostics test. It is likely only to be run when on the phone with a servicer. Before running this test, ensure you have a way to accurately measure the number of ounces dispensed. The test takes a total of about 45 seconds, water will pulse through the machine several times, with corresponding numbers showing up on the screen. Servicers will only need the last number.

*Flowmeter math: The number on the screen is the number of rotations the flowmeter counted. Multiply this number by 0.042 to calculate the number of ounces delivered. This should match the measured number of ounces dispensed.*

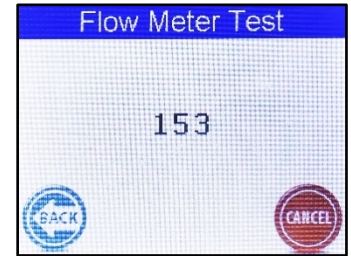

## DRAIN WATER LINES

Drains water currently inside of the machine tubing. Note that draining the water tank is separate, and is done manually. Takes just under 1 minute, and returns to Factory Programming screen when complete. From this screen, follow these steps:

1. Turn off water and disconnect from water line.
2. Drain tank. See page 26.
3. Press the green "Brew" button to run the draining program.



## FACTORY RESET

Resets every single setting, including flowmeter adjustment and all recipe settings. Press and hold the reset button for 3 seconds to reset the machine- there will be a countdown on the screen.



## CALL FOR SERVICE

Allows for entry of a single phone number, including area code. This number will show up before error codes are displayed.

*Note: the machines do not come with a number in them. If you do not enter in a phone number, there will be no screen popping up before error messages.*

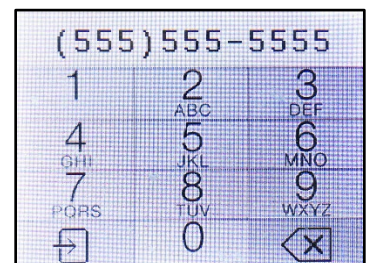

## EXIT

This will take you back to the Hardware and Software Version screen, which will then change to the Drink Selection Screen after a few moments.

# MACHINE OPERATION

To brew a drink, place a cup under the brew nozzle first. Make your drink selection and place a pod, flat side up, in the brew chamber. Do NOT pinch your pod, it should be flat when placed in the machine.

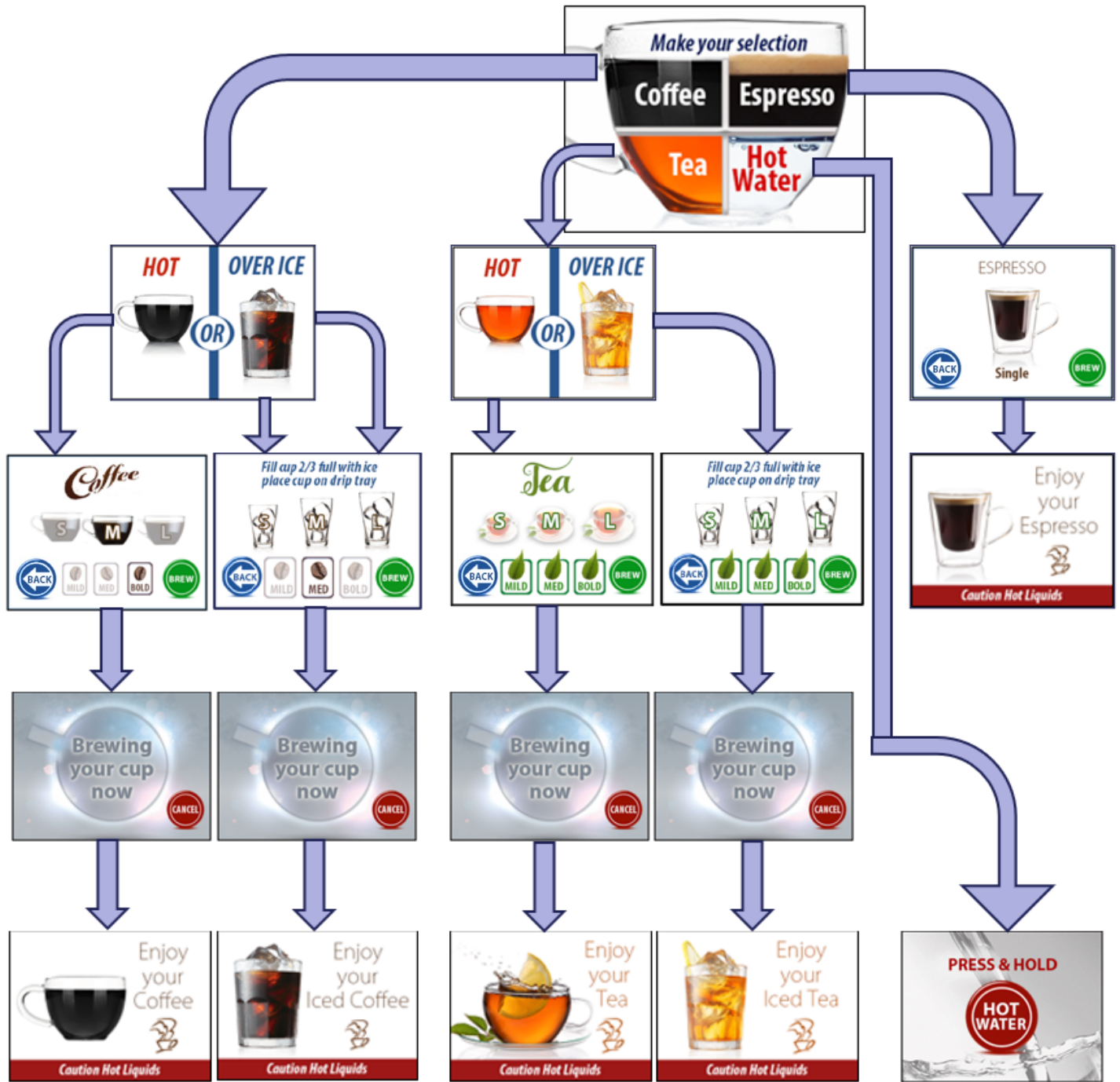

# DRINKS SUB MENU



Cup size

Highlighted option is the one that is selected

Brew strength



# USB INTERFACE CONNECTION

The Fresh Cup 4 Touch Machine utilizes a built in USB connection for updating files in the field. Several types of files can be updated using this interface.

1. User generated graphics files. These include a User Logo, Background Splash, and Call for Service screen.
2. User generated Drink Recipes. A custom Drink Recipe file can be generated and loaded to customize the Drink Recipes.
3. Future Firmware Updates. Any future Firmware or Graphics updates will be e-mailed from Newco with instructions on how to load.

The connection is located behind the waste bin, next to the waste bin detection switch, and is accessed by removing the waste bin assembly and protective plug from the USB socket.

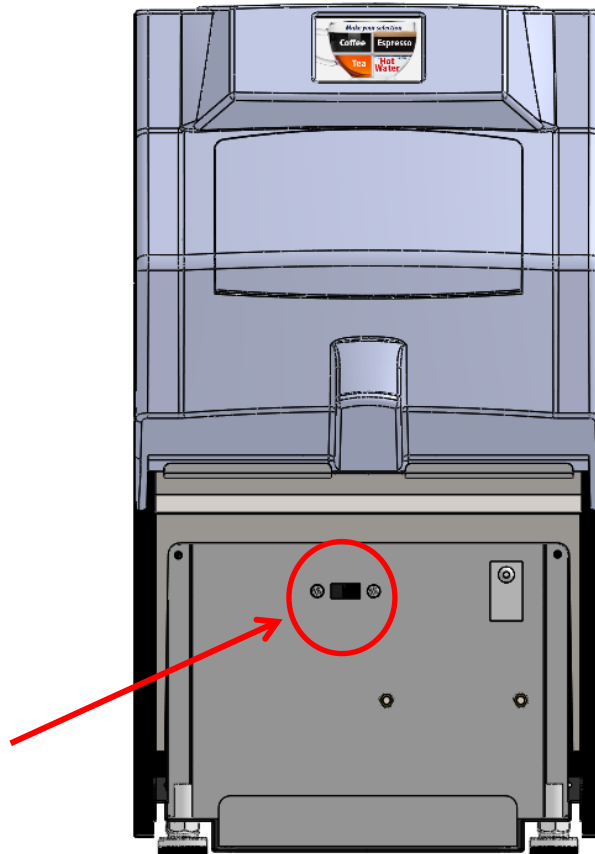

## USER GENERATED GRAPHICS FILES

Three Specific Bitmap files (BMP) can be loaded directly from a USB Flash Drive into the Fresh Cup 4 Display. These files must be 8 bit 320 x 240 pixel format and Landscape oriented, and output as a Window Bitmap file. An image conversion program should be used to convert landscape graphics images to the correct format. This example setup screen is shown from a shareware program- -Easy Graphic Converter V1.2 --available from Etrusoft.com, a link is provided in the .pdf file named "Graphics" on the USB flash drive included with the machine.

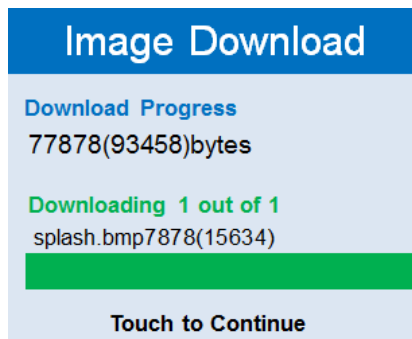
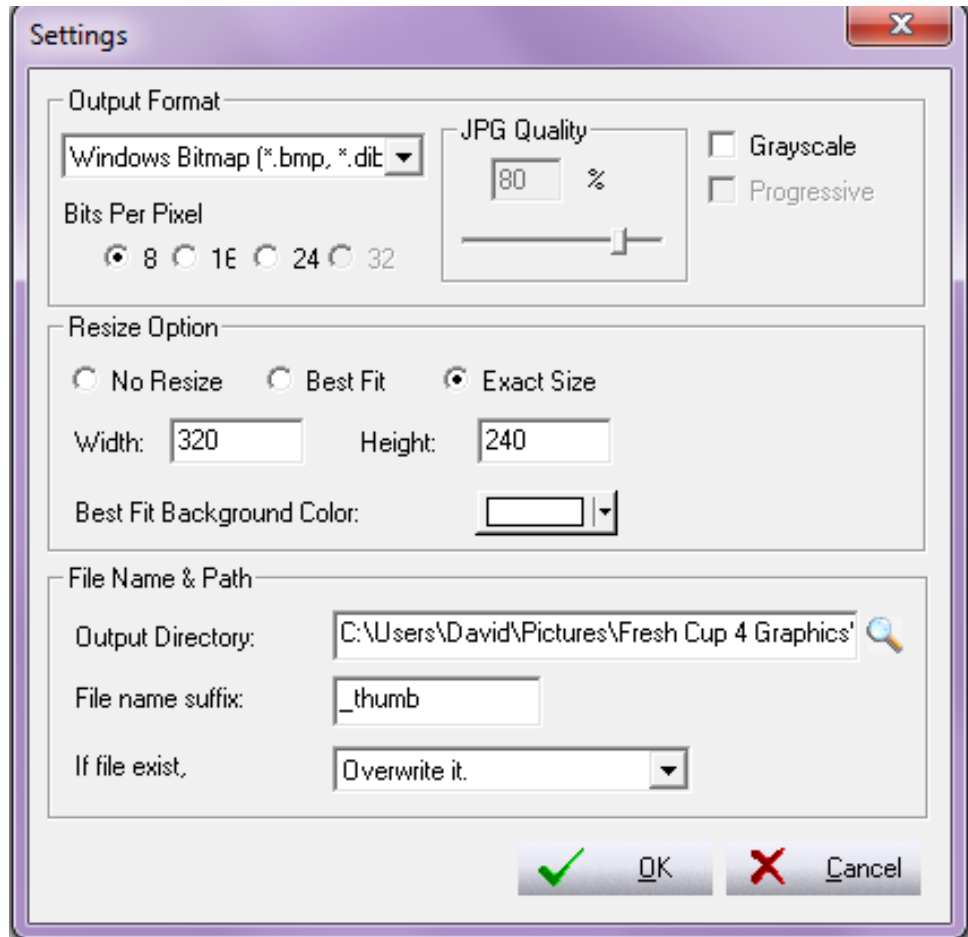

## CUSTOM LOGO GRAPHIC

Use the image conversion program to convert a landscape image (such as a Customer Brand Logo) and note where the file is saved in the output directory. This file will have `_thumb` suffix to show that it has been converted. *Rename the converted file `logo.bmp` and copy it onto a USB Flash drive* (ensure that the Flash drive does not already have a file named `logo.bmp`).

To load the file into the Fresh Cup 4 Touch, turn off the power switch, insert the Flash drive into the USB outlet, and switch the power back on. The screen will remain blank and the Blue Cup light will begin to flash. A message will then be displayed that indicates the new file has been transferred as displayed by the green status bar. Touch the screen to return to normal mode.

## CUSTOM CALL FOR SERVICE GRAPHIC

Use the image conversion program to convert a landscape image (such as a Service Co Logo) and note where the file is saved in the output directory. This file will have `_thumb` suffix to show that it has been converted. *Rename the converted file `eservice.bmp` and copy it onto a USB Flash drive* (ensure that the Flash drive does not already have a file named `eservice.bmp`).

To load the file into the Fresh Cup 4 Touch, turn off the power switch, insert the Flash drive into the USB outlet, and switch the power back on. The screen will remain blank and the Blue Cup light will begin to flash. A message will then be displayed that indicates the new file has been transferred as displayed by the green status bar. Touch the screen to return to normal mode.

*Note: if a phone number has been entered under the call for service menu option it will be displayed on the eservice screen.*

## CUSTOM SPLASH SCREEN GRAPHIC

This graphic image is displayed when the power to the machine is cycled on. This is the only place this graphic is seen. Use the image conversion program to convert a landscape image (such as a Coffee Co Logo) and note where the file is saved in the output directory. This file will have `_thumb` suffix to show that it has been converted. *Rename the converted file `splash.bmp` and copy it onto a USB Flash drive* (ensure that the Flash drive does not already have a file named `splash.bmp`).

To load the file into the Fresh Cup 4 Touch, turn off the power switch, insert the Flash drive into the USB outlet, and switch the power back on. The screen will remain blank and the Blue Cup light will begin to flash. A message will then be displayed that indicates the new file has been transferred as displayed by the green status bar. Touch the screen to return to normal mode.

## USER GENERATED DRINK RECIPES FILE

An application named Fresh cup recipes.exe is also included on the USB Flash storage device. Use it to develop custom recipe values and then transfer the new values to the Fresh Cup 4 touch machine using the USB interface on the machine.

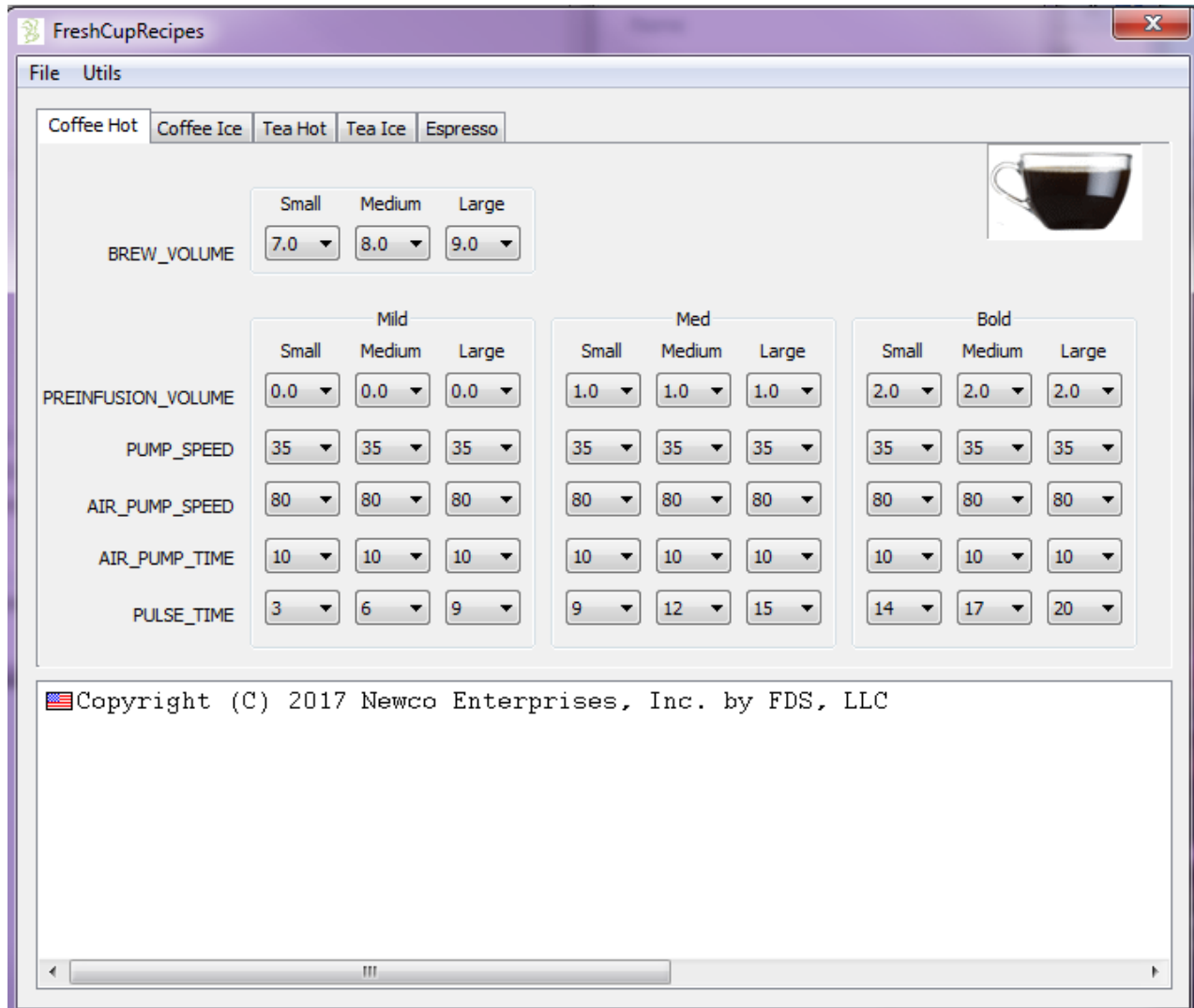

Adjustments to the recipe values can be made using the drop down tabs and selecting the desired values. Once the new recipe set has been selected, the file should be saved as filename **recipes.txt**. When viewed in a file browser the filename should appear as recipes.txt and saved or transferred to the USB flash storage device.

*Note: use the Utils Menu to reset the recipe values to the Factory Defaults.*

# SERVICING THE MACHINE

The Fresh Cup machine has a hot water tank assembly and brew mechanism. These assemblies can be easily removed from the machine.

## SIDE PANEL REMOVAL

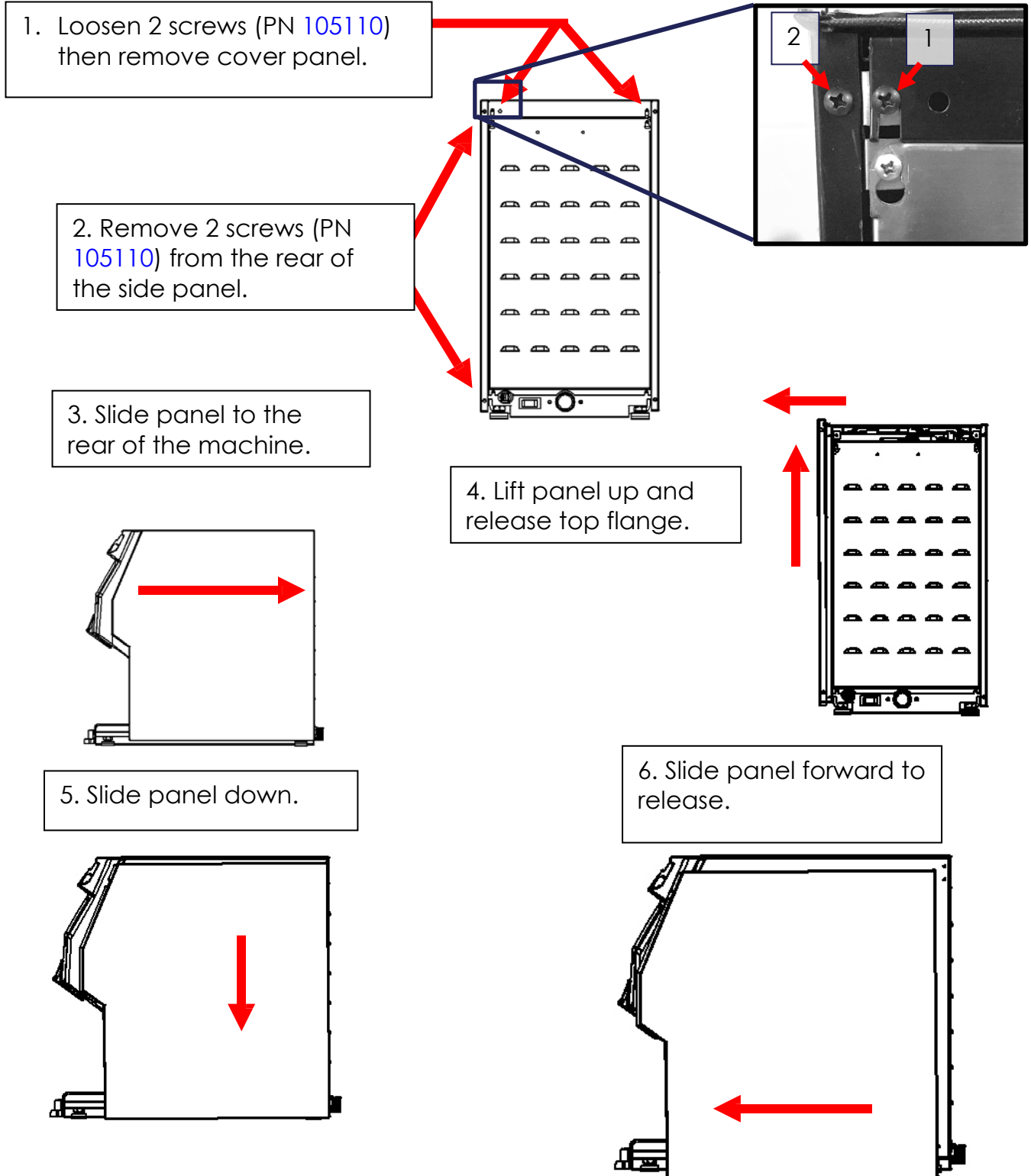

## REMOVING THE BREW MECHANISM

Remove brass knurled nuts (PN 700021). Be sure you do not lose the washer.



Next, disconnect the water connection, and the harness connection.

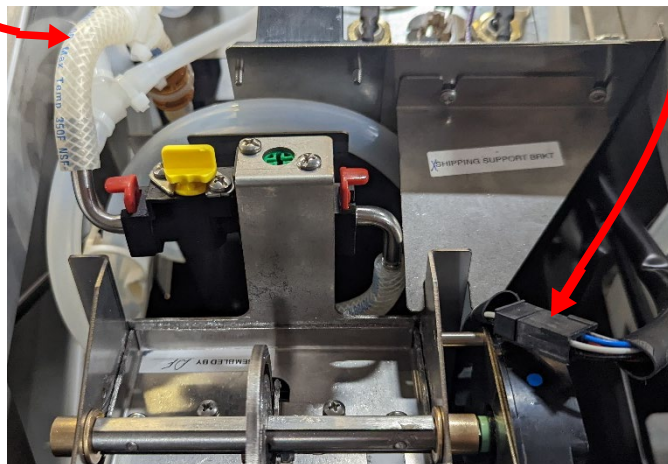

*Note: Shipping Support Bracket must be removed*

## DRAINING THE HOT WATER TANK.

Tank holds approximately 1 US gallon.

*Caution-* The water is extremely hot and can cause harmful burns, unless the hot water tank is left to cool. Do not store in freezing conditions as residual water may remain in machine.

### METHOD 1

#### TO DRAIN

1. Unplug machine and remove waste bin. Allow machine to cool before proceeding.
2. Reaching up into the machine from where the waste bin sits, locate the tube clip on the left side of the opening. Follow the tube up to locate the drain tube bracket. See *Image 1*.
3. Push the tubing up to release it from the bracket. You may need to follow the bracket to the right and push up on the tube from the right side to fully release the drain tube.
4. Pull the tubing down and out to the front of the machine.
5. Remove the tube plug using pliers, then aim end of tube to where you are draining the water. Push up on tube clip to open tube. See *Image 2*.

#### TO REPLACE

1. Once the tank is fully drained, tighten the tube clip and insert the drain plug
2. Feed the tube back up into machine, starting from right side of the tubing.
3. Locate the tubing bracket and line tube up with bracket.
4. Using your fingertips, press on the tube and roll it down into the bracket until secure.
5. Ensure tube clip is tucked away on the left side of the tank plate so that it does not interfere with brewing mechanism.

### METHOD 2

#### TO DRAIN

1. Unplug machine and remove waste bin. Allow machine to cool before proceeding.
2. Remove top cover of machine. See *page 27*.
3. Locate drain tube and drain tube bracket. See *Image 1*.
4. Starting on the left side, pull drain tube up out of the bracket. Once free, feed the drain tube down and out to the front of the machine.
5. Remove the tube plug using pliers, then aim end of tube to where you are draining the water. Push up on tube clip to open tube. See *Image 2*.

#### TO REPLACE

1. Once the tank is fully drained, tighten the tube clip and insert the drain plug.
2. Feed the tube back up to top of machine, starting from right side of the tubing.
3. Line the tubing up with the drain tube bracket, then, starting on the right side, push and roll down to secure tubing into bracket.
4. Ensure tube clip is tucked away on the left side of the tank plate so that it does not interfere with brewing mechanism.
5. Replace top cover of machine.

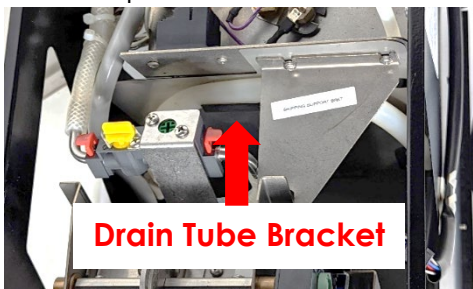

*Image 1*

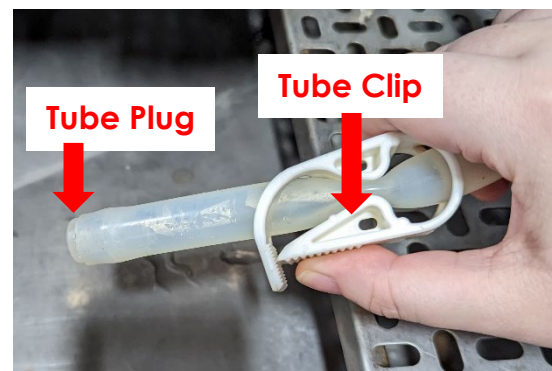

*Image 2*

## TANK REMOVAL & ACCESS AREAS

Note: Cover panel must be removed before removing side panels.

### TANK REMOVAL

1. Remove top cover by loosening 2 screws (PN 105110), then remove the back cover by loosening 4 screws (PN 102333).

2. Remove 2 different nuts- PN 107069 near rear and PN 107240 near front.

3. Loosen 2 screws (PN 105043) then push down to release shipping bracket.

Side Panel    Top Cover

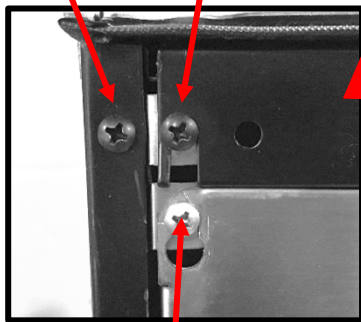

Back Cover

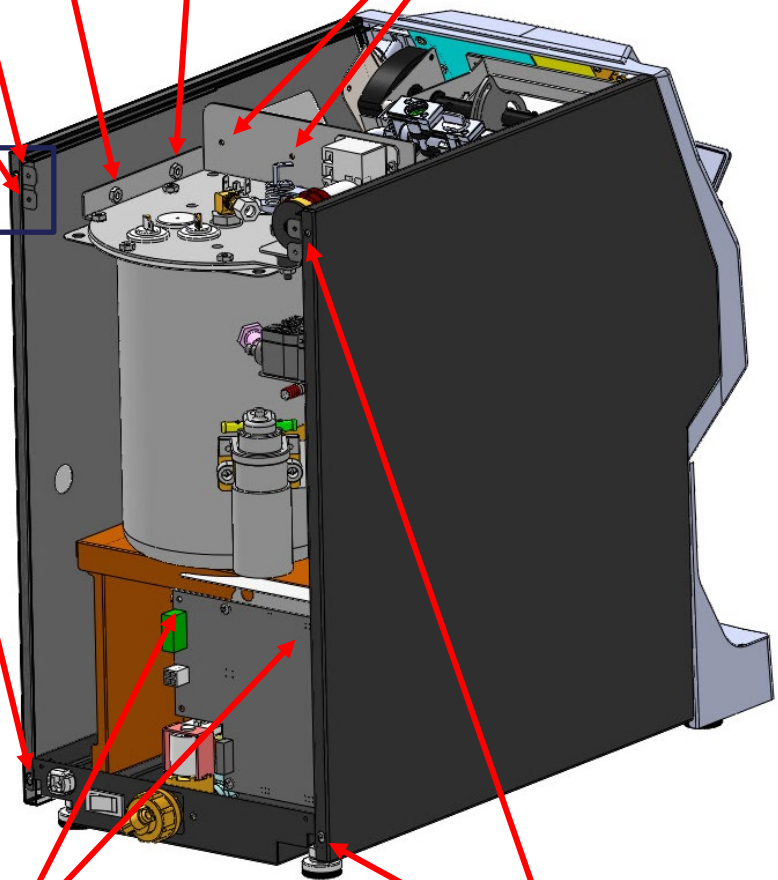

Loosen but do not remove 2 screws (PN 105048), then lift and pull control board & bracket out of the machine to access transformer

Remove 2 screws (PN 105110) to remove side panel for pump access

## ERROR MESSAGES

A phone number for your servicer should pop up for 15 seconds before the error message displays. The error message will show for 5 seconds then loop back to the servicer phone number.

### THERMISTOR IS OPEN

First make sure the thermistor is connected properly. If connected, then you may need to replace PN [151677](#)



### THERMISTOR IS SHORT

Replace PN [151677](#). If this error returns after replacing the thermistor, then it is likely there is a control board failure.



### CHECK WATER

Possible pump, flowmeter, or control board error. Check connections at the flowmeter.

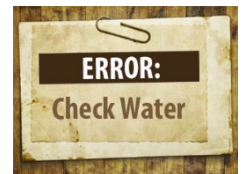

### UPPER MOTOR

Brew Chamber Drive Motor Error. Check for jam or obstruction in brew chamber. Also possible that the wiring harness has a bad connection



### LOWER MOTOR

Brew Chamber Drive Motor Error. Check for jam or obstruction in brew chamber. Also possible that the wiring harness has a bad connection

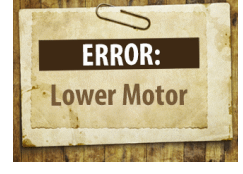

### FILL TIMEOUT

Water not reaching level probe in a timely manner. Check water supply for disconnections or leaks.

**NOTE:** Due to large tank capacity, fill time out error may occur on startup. Please turn machine off, and then back on to clear the error and continue filling.

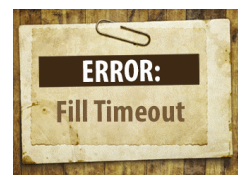

### CHECK HEATER

Water is not heating up at expected rate- at least 1°F rise in temperature over 4 minutes, or heater has been running continuously for 30 minutes. Check Hi Limit Thermostat (PN [111593](#)), then check heating element (PN [704166](#) for US 1700W or [704161](#) for Canada 1400 W), lastly check heater relay (PN [110958](#)).

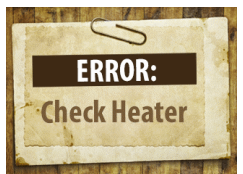

# INSIDE YOUR MACHINE

## UNIVERSAL 2 POD BREWING MECHANISM

### 780585

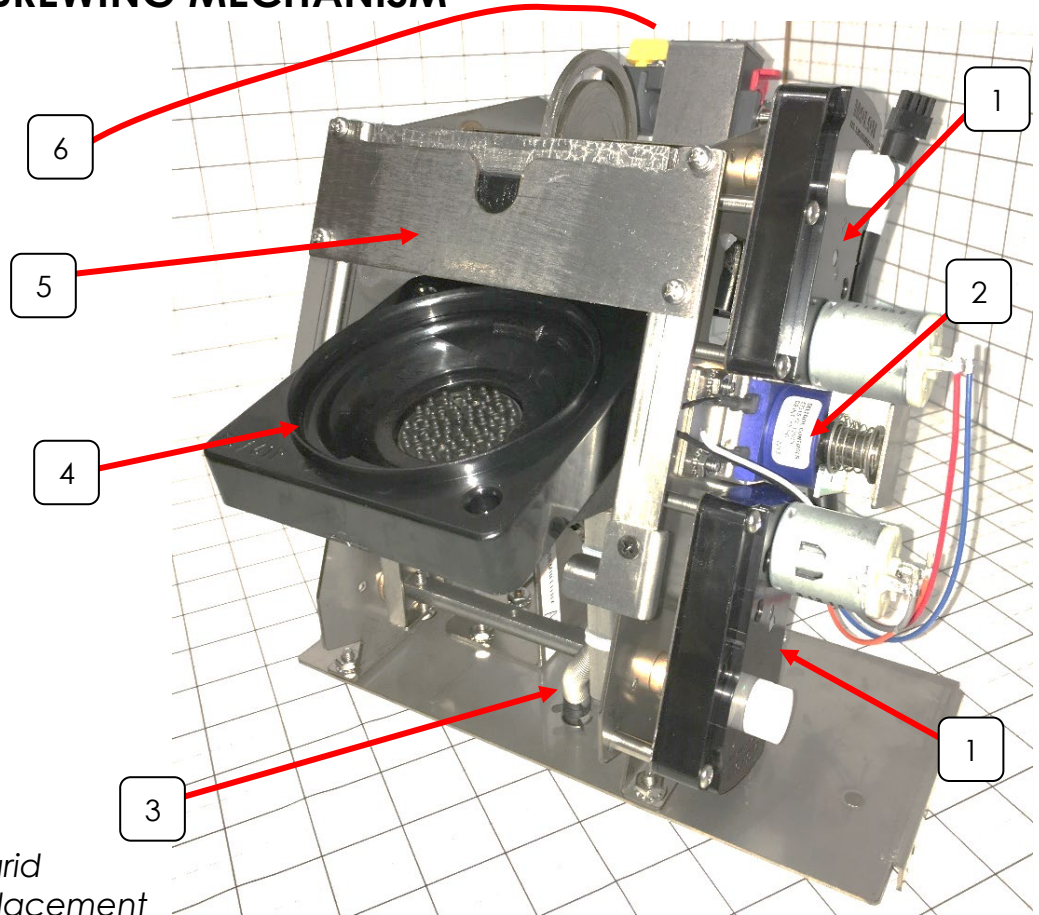

Picture taken on 1 inch grid  
Newco has many replacement kits available

ITEM	PART NUMBER	DESCRIPTION	QTY
1	780230	BREW MECH MOTOR	2
2	780231	DELTROL SOLENOID	1
3	780368 & 780320	BREW HOSE WITH PROTECTIVE SPRING	1
4	780871	LOWER BREW CHAMBER UNIVERSAL 2 ASSEMBLY	1
		6-32 SCREWS	
		O-RING	
		¼" X 1" STANDOFF SPACER	
		COMPRESSION SPRING	
		CUP WASHER	
		DISC ASSY, MOLD, 13 HOLE	
		LOWER BREW CHAMBER	
5	780775	UPPER BREW CHAMBER ASSEMBLY	1
	773246	U-CUP SEAL	
		UPPER BREW CHAMBER	
6	320043	VALVE WITH SHOUT OFF	1

NOTE: Your machine can be equipped with various optional brew mechanisms to provide brewing choices tailored to your specific needs. For information on these optional brew mechanisms and associated replacement parts contact NEWCO Technical Services at 1-800-556-3926 or NEWCO Customer Service at 1-800-325-7867

# TANK ASSEMBLY 780619

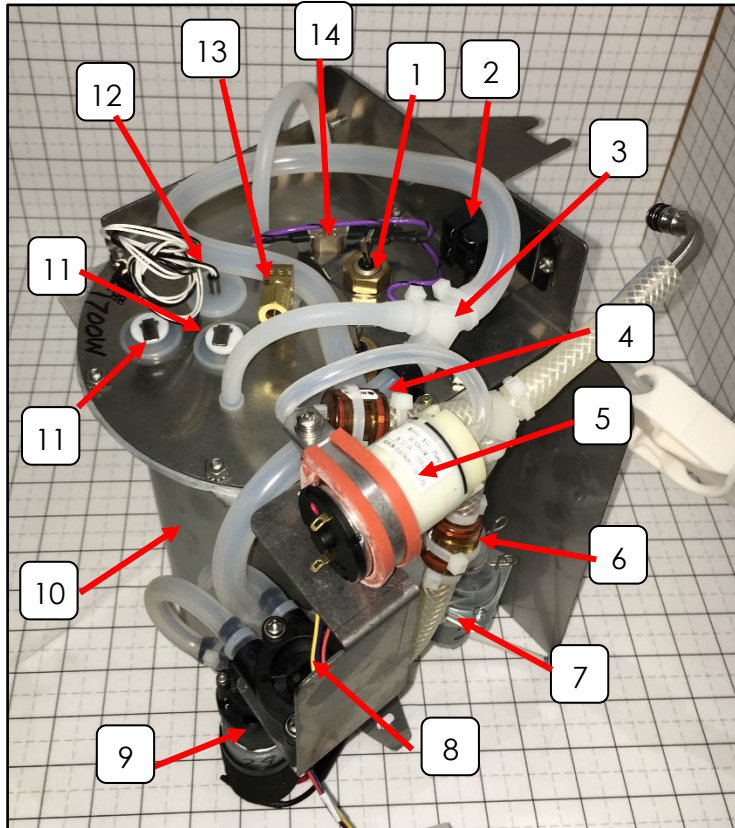

# 783371(ALTERNATE)

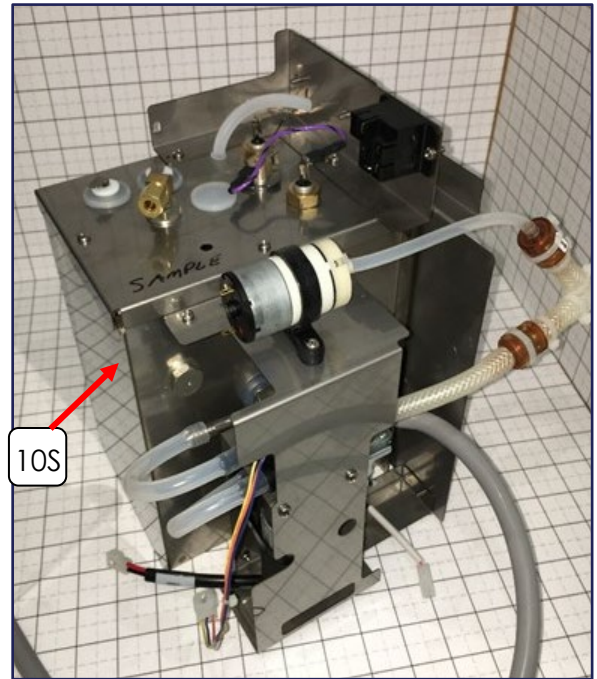

NOTE: Due to large tank capacity, fill time out error may occur on startup. Please turn machine off, and then back on to clear the error and continue filling

ITEM	PART NUMBER	DESCRIPTION	QTY
1	704166 (1700W)	TANK HEATING ELEMENT (US)	1
	704161 (1400W)	TANK HEATING ELEMENT (CAN)	1
2	110958	RELAY, 12 VDC SPST 30A	1
3	767281	"Y" HOSE FITTING	1
	780090	AIR PUMP KIT	1
4	202165	CHECK VALVE ASSEMBLY	
5	773056	AIR PUMP	
6	202178	WATER PUMP CHECK VALVE	1
7	781772	PUMP ASSEMBLY W/ELBOW (HOT WATER)	1
8	120682	DEFOND FLOWMETER	1
9	109937	GEAR PUMP ASSEMBLY	1
10	780253	ROUND TANK	1
	780647	TANK LID (ROUND)	
	704221	TANK GASKET (ROUND TANK)	
10S	783372	SQUARE TANK ONLY	1
	783377	TANK LID (SQUARE)	
	119882	TANK GASKET (SQUARE)	
11	500384	PROBE KIT 1.818"	2
	151677	DUAL TEMP THERM PROBE	1
13	100149	ELBOW 1/4 C x 1/8NPT	1
14	111592	HI-LIMIT THERMOSTAT	1

# FRONT PANEL 780750

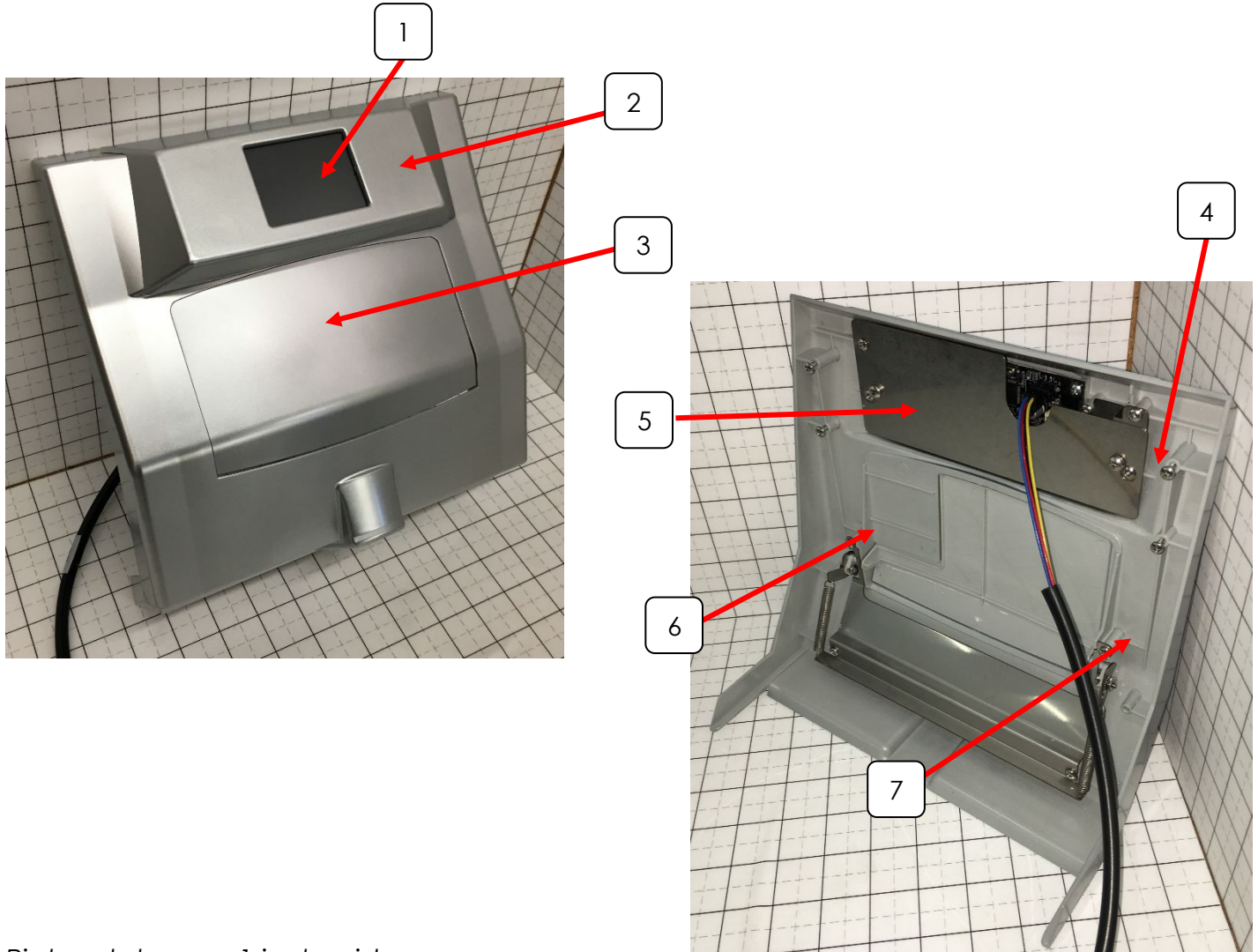

Picture taken on 1 inch grid

ITEM	PART NUMBER	DESCRIPTION	QTY
1	782199	TOUCH SCREEN DISPLAY ASSEMBLY	1
2	780751-SV	TOUCH SCREEN BEZEL	1
3	780603-SV	BREW MECHANISM DOOR	1
4	780753	BEZEL RETAINERS	2
5	780752	TOUCHSCREEN PROTECTOR/ COVER	1
6	780635	RIGHT PIVOT SPRING BRACKET	1
7	780628	LEFT PIVOT SPRING BRACKET	1

# ELECTRICAL COMPONENTS

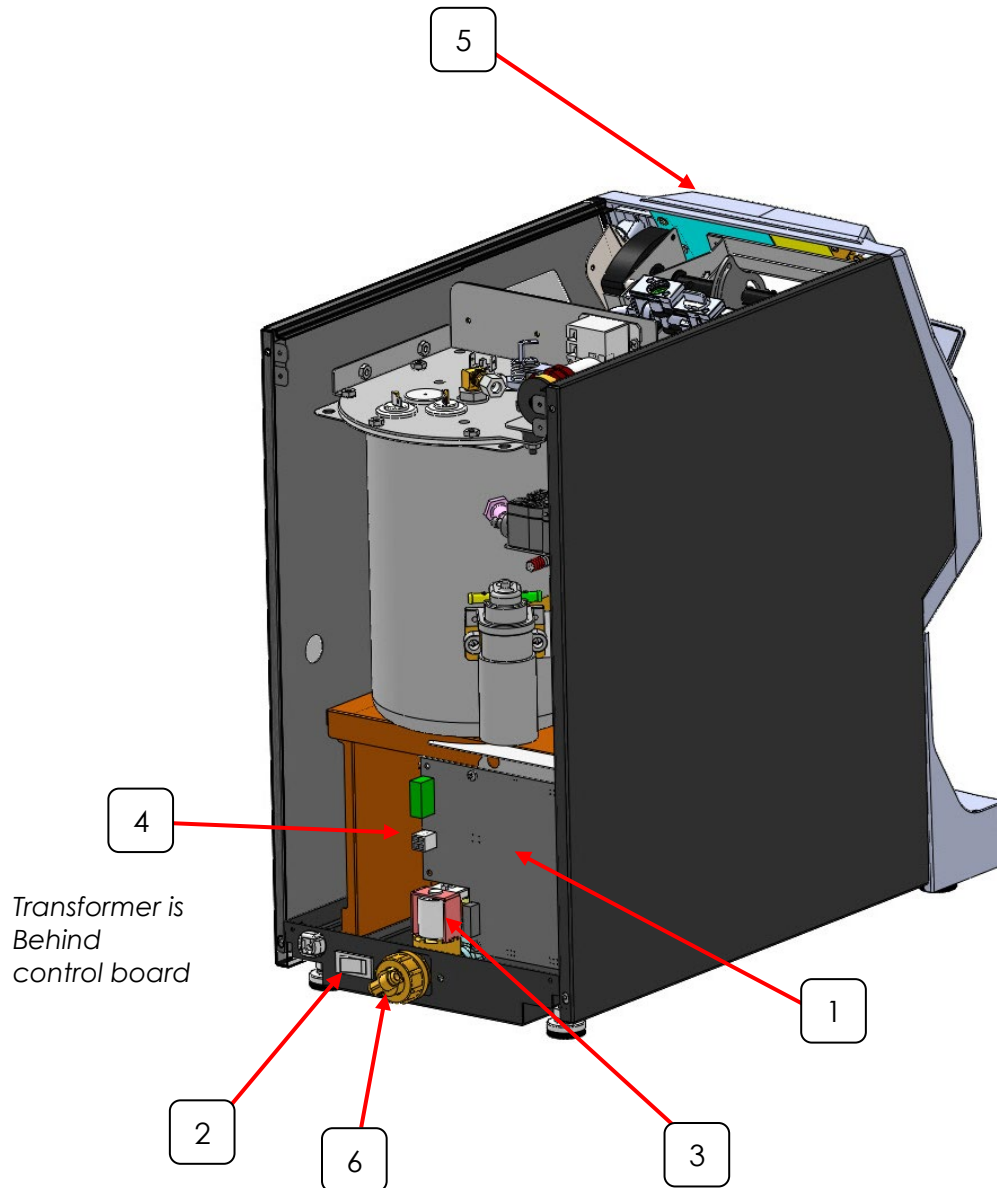

ITEM	PART NUMBER	DESCRIPTION	QTY
1	782165	CONTROL BOARD & BRACKET	1
2	<a href="#">110626</a>	SWITCH, DPST, ON/OFF	1
3	780365	SOLENOID FILL VALVE ASSEMBLY	1
4	<a href="#">105115</a>	TRANSFORMER 120VAC-24VAC	1
5	782199-10	TOUCH SCREEN DISPLAY ASSEMBLY	1
6	111775	INLET ASSEMBLY	1

# WIRING DIAGRAM

Wire colors are subject to change based on availability.

