

FRONT LOAD POST MIX BEVERAGE DISPENSER

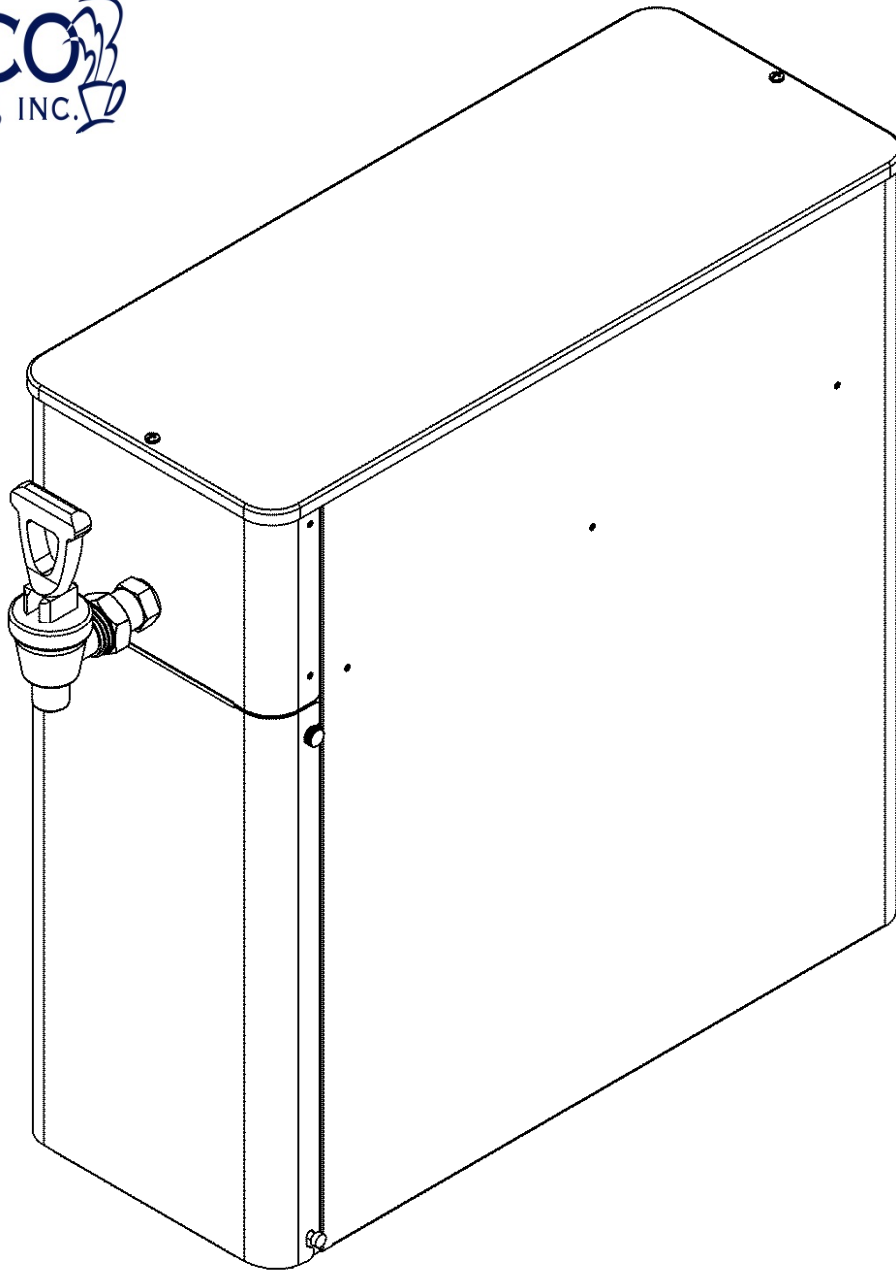

The front load post mix dispensers are designed for use with bag in box concentrated teas, lemonades, coffee's and similar products. The system utilizes a proprietary venturi system to mix the proper ratio of concentrated syrup with water to produce a finished beverage of a consistently high quality. The truncated cone tip and longer thread engagement of the adjustment screw allow for easier and more precise control of the product ratio than competitive units. The front load system's unique arrangement of components allows for loading the heavy BIB container into the lower compartment without having to remove the bag from the box. Likewise, all service points are conveniently located below the top cover or on the back of the unit providing for exceptional ease of adjustments and service.

INSTALLATION

1. Carefully remove the dispenser from the shipping carton.
2. The waterline must be flushed to remove any foreign particles prior to connection to the dispenser. Use of a filter designed to reduce scale, sediment, and off taste or odors is recommended where water quality is a concern. If a water filter is used, follow the filter manufacturers recommendation for flushing prior to connection to the dispenser.
3. **CAUTION:** Maximum water pressure at line connected to the dispenser should not exceed 75 PSI. It may be necessary to install an external pressure regulator to reduce the water pressure to a lower level, such as 40-50 PSI if the recommended pressure is routinely exceeded. Pressure should be no less than 20 PSI with 25-50 PSI being optimal.
4. Connect waterline to the inlet fitting on the rear of the dispenser. The standard fitment provided is a ¼" flare connection as shown in the illustration below.
5. Turn on the water source to the dispenser. Turn the yellow shut off handle to the ON position. See illustration below. **CAUTION** – It is recommended that the water supply on the back of the unit be turned to the off position during non-business hours.

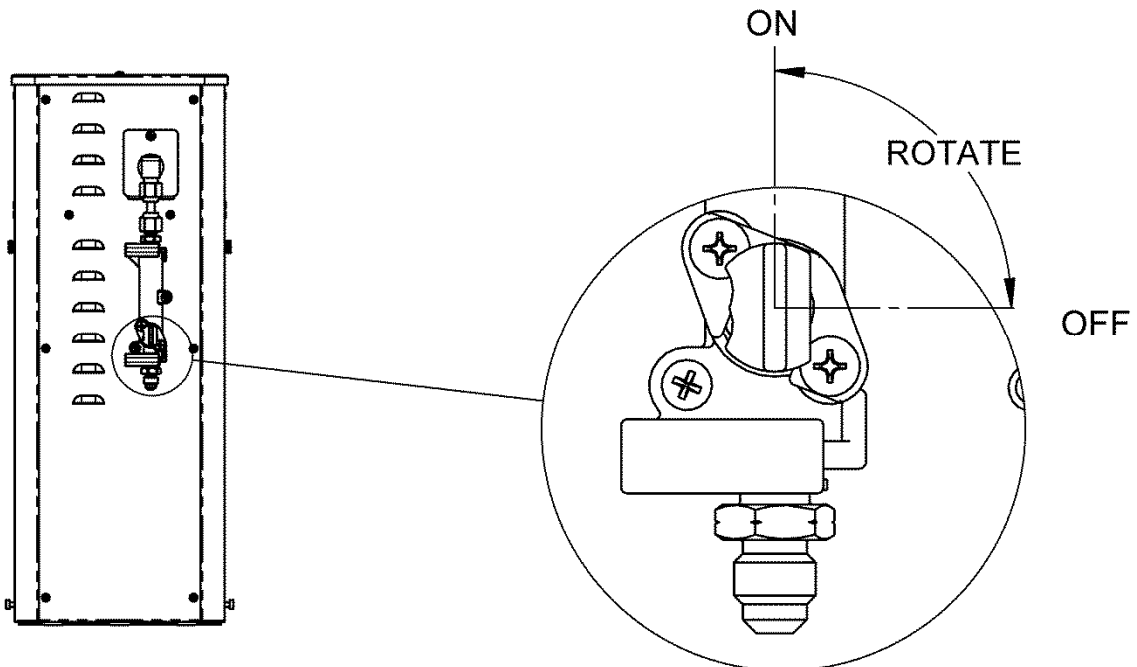

Scholle Connector



Liqui-Box QC/D Connector

PRODUCT LOADING

1. Loosen the two thumb screws on the sides of the front access door. A magnetic catch is now holding the door in the upright position.
2. Grasp the sides of the door right below the thumbscrews and pull the door forward to the approximate angle as shown in the illustration below.
3. Lift the door to remove from the hinge pins (shoulder screws) See the detail view below. Set door carefully aside.
4. Disconnect empty BIB and remove if applicable. Install new BIB into product compartment.
5. Open the BIB to expose the dispensing spout. Pull spout out and remove cap.
6. Connect fitment to BIB. Scholle type fittings, lower left image on preceding page, screw on and off. QC/D fittings, lower right image on preceding page, require the center portion of the fitting to be lifted to allow the fitting to be connected or disconnected. Fitting must be pulled all the way out to expose the word "out" as shown below left. The connector can then be slid on or off as shown below right. The center portion of the fitment should be pushed fully in, flush with collar, for dispensing. A distinctive click will be heard when the center fitment is fully pushed in.
7. Reinstall front door by reversing steps 1-3 above. NOTE: Ensure the slots on both sides align with the hinge pins as shown in the detail view below.

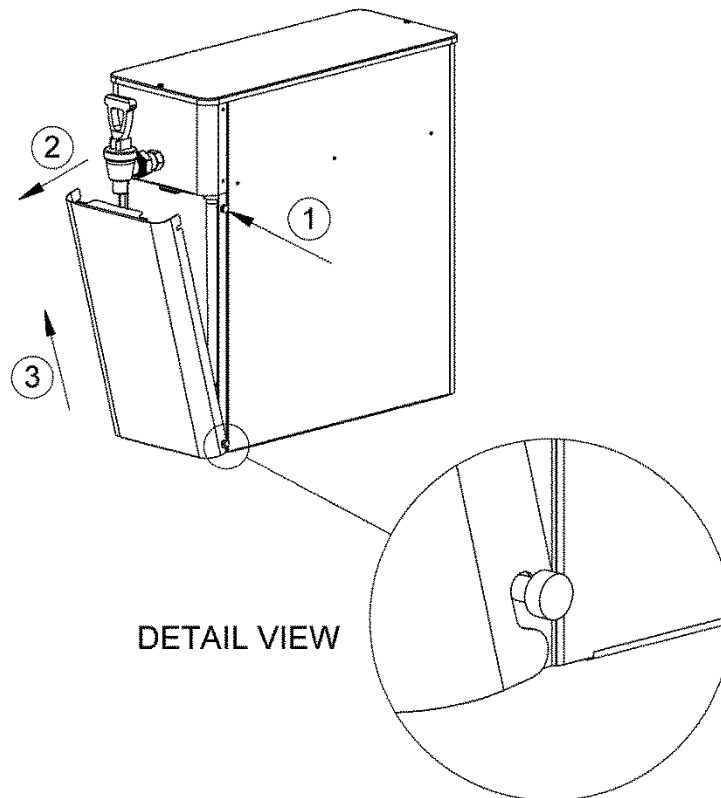

PRIME SYSTEM

1. After the BIB has been connected, place a cup or pitcher below the faucet. Pull the faucet handle to dispense approximately 12 ounces of product. If concentrate has not reached faucet, repeat.
2. Dispense another 8 ounces of beverage and sample for taste and/or brix reading. If an adjustment is necessary, refer to the "TASTE CALIBRATION" section, below.

TASTE CALIBRATION

Follow the steps outlined below If an adjustment to the beverage taste is required.

1. Remove the 2 screws securing the top cover on the dispenser. Remove the top cover.
2. The strength adjustment is located at the front of the dispenser. See diagram below. A standard screwdriver is required to turn the adjustment screw.
3. Turn the screw counterclockwise to increase the strength and clockwise to decrease the strength. This will allow more or less beverage concentrate through to mix with the water.
4. **DO NOT ATTEMPT TO ADJUST** the pressure regulator to control the strength of the beverage. The regulator has a fixed pressure setting and is **NON ADJUSTABLE**.
5. Replace top cover and secure with screws removed in previous step.

TOP VIEW OF DISPENSER, COVER REMOVED

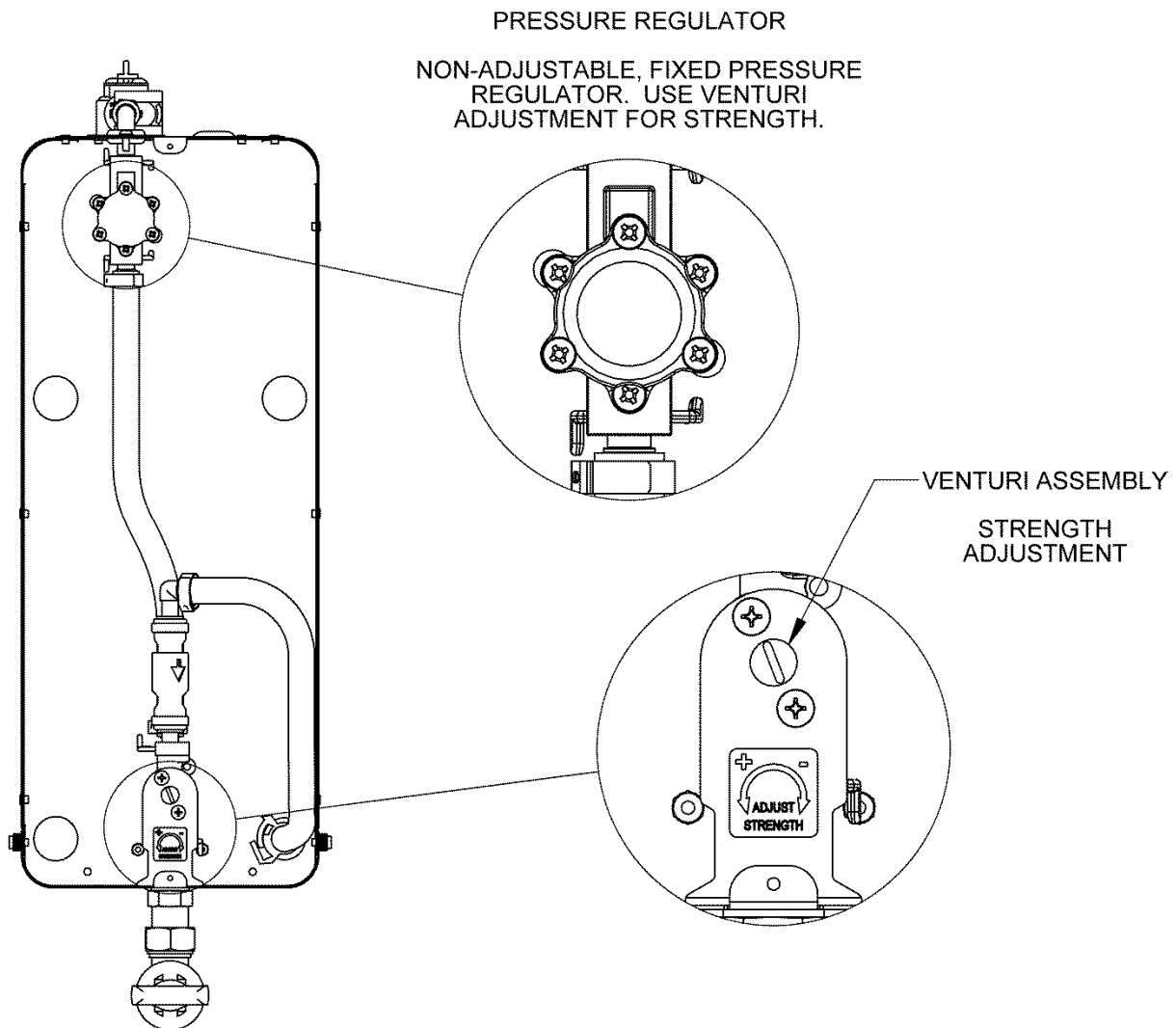

FRONT VIEW
DOOR REMOVED

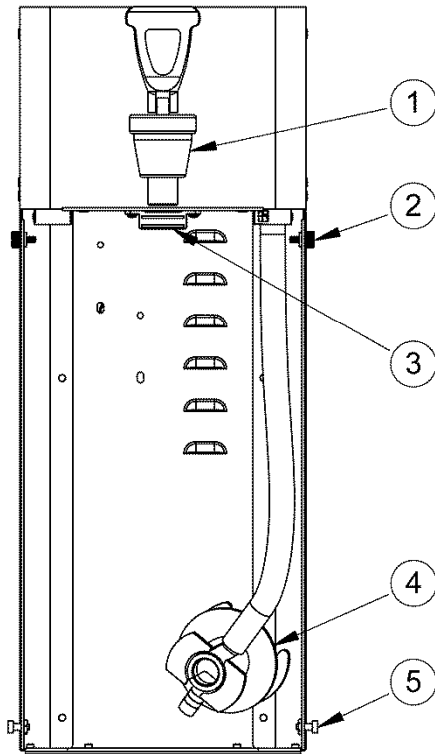

TOP VIEW
COVER REMOVED

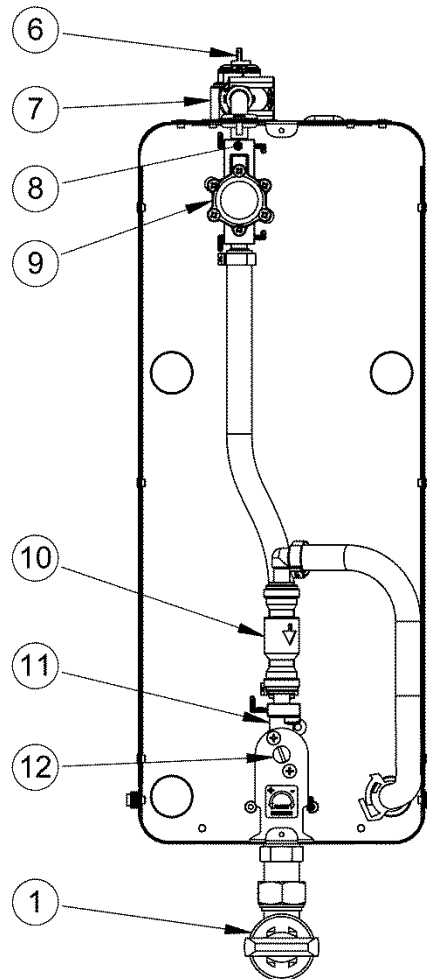

ITEM	DESCRIPTION
1	FAUCET
2	THUMB SCREW
3	MAGNETIC CATCH
4	BIB CONNECTOR (QCD SHOWN)
5	SHOULDER SCREW (DOOR HINGE)
6	WATER SHUTOFF (SHUTOFF WHEN UNATTENDED)
7	STRAINER/SHUTOFF ASSEMBLY
8	CHECK VALVE, WATER (INTERNAL, NON-SERVICEABLE)
9	PRESSURE REGULATOR (FIXED PRESSURE, NON SERVICEABLE)
10	CHECK VALVE, SYRUP
11	VENTURI ASSEMBLY
12	RATIO ADJUSTMENT

CLEANING INSTRUCTIONS

To clean and flush lines before connecting BIB product to unit or when changing product. Flush should be performed at least once a week.

Note: Cleaning requires the use of a cleaning/flush adapter. An adapter allows the check valve in the connector to stay open during the cleaning process. Cleaning adapters are reusable and may be saved for later use. An adapter may be purchased from Newco Enterprises, Inc. Part numbers are:

#320282 for QCD cleaning/flush adapter.

#120508 for Scholle cleaning/flush adapter.

A cleaning adapter may also be made by taking an empty BIB bag and cutting away as much of the empty bag as possible. Wash the remaining connector and further trim off any remaining bag pieces if desired. This is now your cleaning adapter.

1. Connect cleaning/flush adapter to QCD or Scholle connector.
2. Place connector with adapter in container of hot water.
Periodic flushing can be done using Newco "EasyClean"; PN [900083](#) (Scholle), 900084 (QCD).
3. Place a pitcher or pail below faucet and hold faucet handle down until clear water runs from the faucet.
4. Turn off water source to dispenser. The dispenser has a shutoff valve on the rear of the unit. See figure at lower left.
5. Open and close the faucet handle to drain any residual water from the system.
6. Unscrew the faucet bonnet assembly from the faucet body. See picture below, right.
7. Wipe the inside of the faucet body with a mild dishwashing soap and hot water.
8. Hand wash the bonnet assembly in the dishwashing soap solution paying particular attention to the seat cup and cap. Rinse bonnet.
9. Reinstall the bonnet assembly to the faucet body using care to avoid cross threading. Hand tighten the bonnet.
10. Turn back on water source and dispense approximately 12 ounces of water.
11. Remove the cleaning adapter from BIB connector.
12. Attach connector to new BIB.
13. Prime the system. See "PRIME SYSTEM".

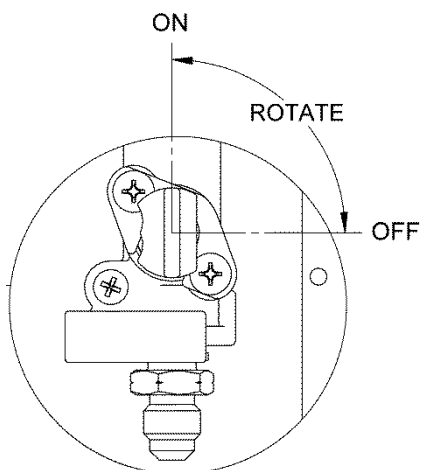

WEEKLY SANITIZING

The following procedure applies to each dispense head/faucet.

1. Follow steps 1-10 of the "CLEANING INSTRUCTIONS" section.
2. Prepare one gallon of food grade sanitizing solution *(200 ppm available chlorine) in a suitable container per the sanitizer manufacturers instructions. Use 100 deg F water.
3. Place BIB connector into the sanitizing solution. Ensure connector is submerged to bottom.
4. Place a large vessel under the faucet. Lock or hold faucet open until container of sanitizing solution is nearly empty. This will leave sanitizer in the beverage line. **DO NOT FLUSH UNTIL THE FOLLOWING MORNING.**
5. Flush by reloading the dispenser with concentrate. Lock or hold faucet handle down until beverage is dispensed from the faucet. Dispense three 8 oz. servings and discard.

* Sanitizing solution with 200 ppm available chlorine can be made by adding ½ oz. (1 tablespoon) of regular household bleach (6% sodium hypochlorite solution) per gallon of water.

DO's and DON'T's for operation and installation

Operation

1. DO fully activate faucet handle when dispensing drinks.
2. DO clean and sanitize dispensing assembly, lines, and faucet weekly.
3. DON'T forget to clean seat cup.
4. DO keep dispenser primed with concentrate at all times.
5. DO reload immediately when concentrate runs out.
6. DO turn off water supply when equipment is left unattended.

Installation

1. DO connect dispenser to a filtered water line.
2. DO flush filters before connecting to dispenser.
3. DO sample finished drink before making adjustments.
4. DO make small strength adjustments and then resample.
5. DON'T adjust water pressure without consulting the manufacturer's tech service at 800-556-3926.
6. DO get sample approval from the customer.

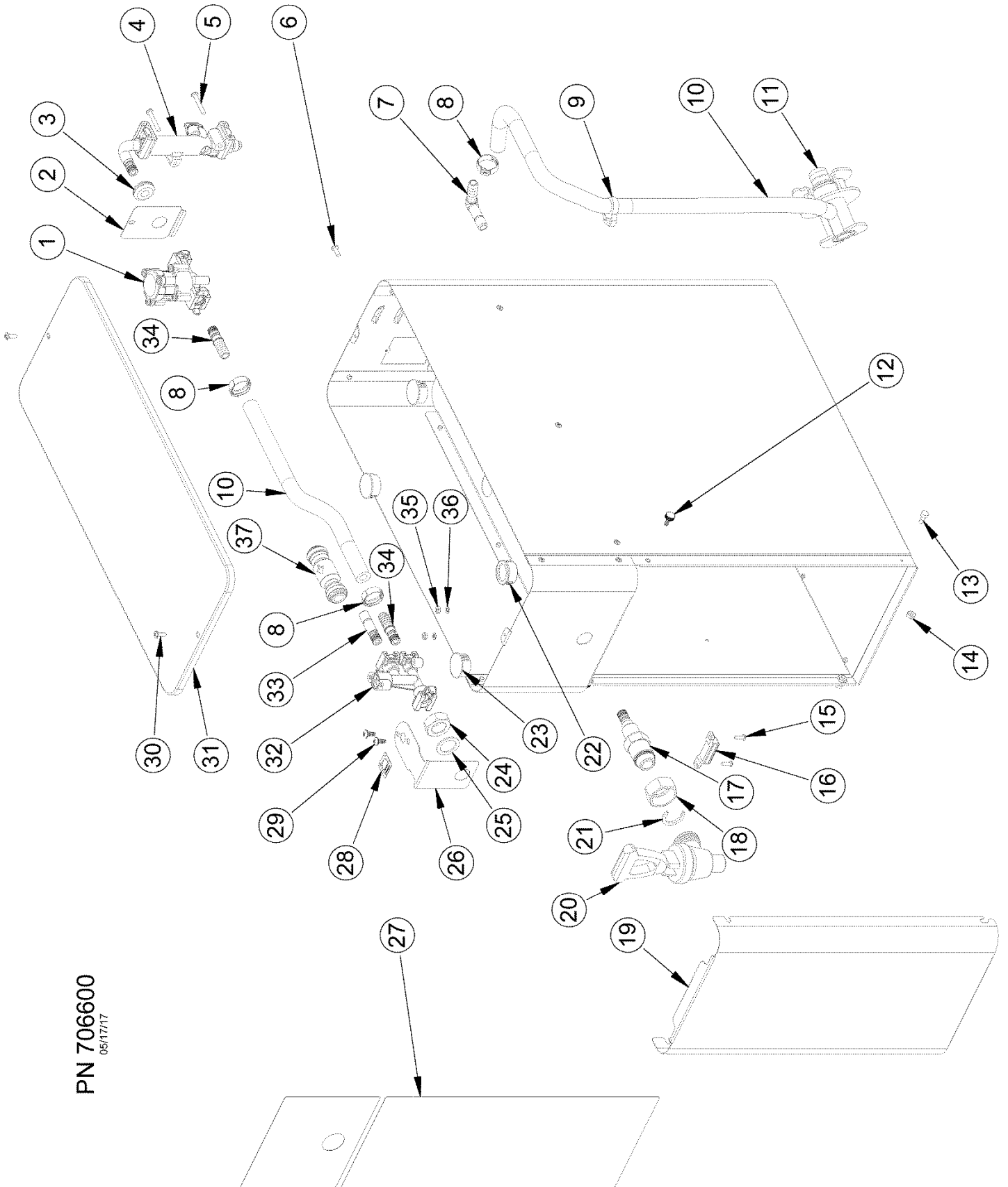

PN 706600
05/17/17

ITEM	PART NO	DESCRIPTION
1	706650	PRESSURE REGULATOR ASSY, NON-ADJUSTABLE
2	706634	PLATE, WATER INLET MOUNTING
3	101938	GROMMET, .359 ID X .875 OD
4	803268	STRAINER ASSY W/SHUTOFF, FL-3/8 DOLE ELBOW
5	500043-B	SCREW, 6-32 * 1, PPHMS, BLK
6	105043	SCREW, 6-32 * 3/8, W/WASHER
7	803033	ELBOW, UNION, 3/8 TUBE * 3/8 STEM, PP
8	803187	CLAMP, STEPLESS, .609/.734
9	120684	CLAMP, SNP8GHS0M4, BLACK
10	803089	HOSE, BRAIDED, .313 ID * .592 OD - SPECIFY INCHES
11	400137	CONNECTOR & FITMENT QCD2
12	706614	SCREW, 6-32 * 3/8, THUMB, BLACK
13	103531	SCREW, 6-32 * 3/16, SHOULDER, S/S
14	101706	NUT, 6-32 HEX, S/S W/NYLON INSERT
15	100055	SCREW, 4-40*3/8, PPHMS, S/S
16	102065	MAGNET, DOOR
17	706495	SHANK, PM FAUCET * 3/8 DOLE, W/O-RINGS
18	104114	NUT, HIGH HEAT FAUCET
19	706607	DOOR, FRONT LOAD PM, 6.7" WIDE
20	800460	FAUCET ASY, BLACK, LEMONADE
21	800007	RING, C TEA URN
22	803205	BUSHING, SNAP, 7/8"
23	803225	PLUG, DOME, 7/8"
24	706006	NUT, HEX, 5/8-18 S/S, .94W*.38H
25	800244	GASKET, .671 * .937 * .062, NYLON
26	706610	BRACKET, SUPPORT, SA VENTURI
27	706615	LABEL, ROYS LEMONADE, FL PM
27	CALL FOR PN	CALL CUSTOMER SERVICE FOR OTHER LABEL OPTIONS
28	706616	LABEL, VENTURI STRENGTH ADJUSTMENT
29	320042	SCREW, 8-16 * 3/8, PLASTITE, PPH
30	102333	SCREW, 6-32 * 3/8, COMBHD SLFTAP, S/S
31	706608	TOP COVER, FRONT LOAD PM, 6.7" WIDE
32	706639	VENTURI ASSEMBLY, PM QC, 078 LEMONADE, XSWEET
	706496	VENTURI ASSEMBLY, PM QC, 095 TEA/LEM
	706497	VENTURI ASSEMBLY, PM QC, 095 COFFEE
33	706492	ADAPTER, 3/8DOLE-3/8STEM, W/O-RINGS
34	320028	FITTING, 3/8 DOLE * 3/8 BARB, W/O-RINGS
35	100243	NUT, 4-40 HEX, S/S
36	110766	WASHER, #4, INTERNAL LOCK
37	703037	VALVE, SINGLE CHECK, 3/8, GUEST
NOT SHOWN	706654	BUMPER (FOOT), SQUARE 3/4 SQ X 1/4 H, REAR
NOT SHOWN	706655	BUMPER (FOOT), ROUND 3/4 DIA X 3/16 H, FRONT

PN 706492

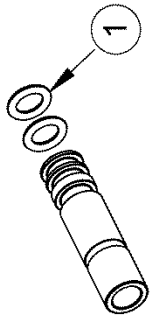

PN 320028

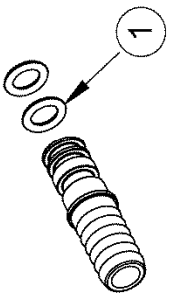

PN 706495

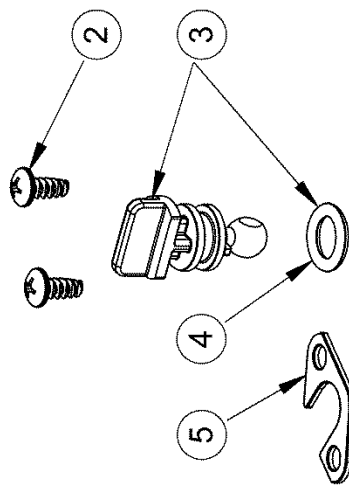
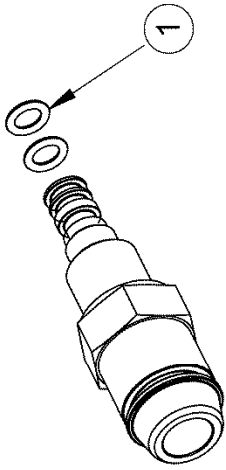

PN 706639

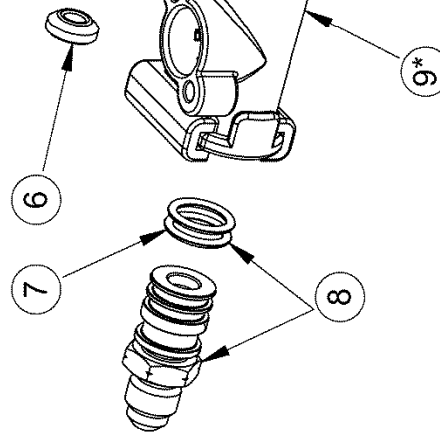
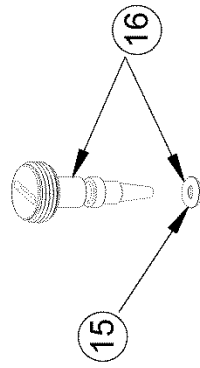

PN 803268

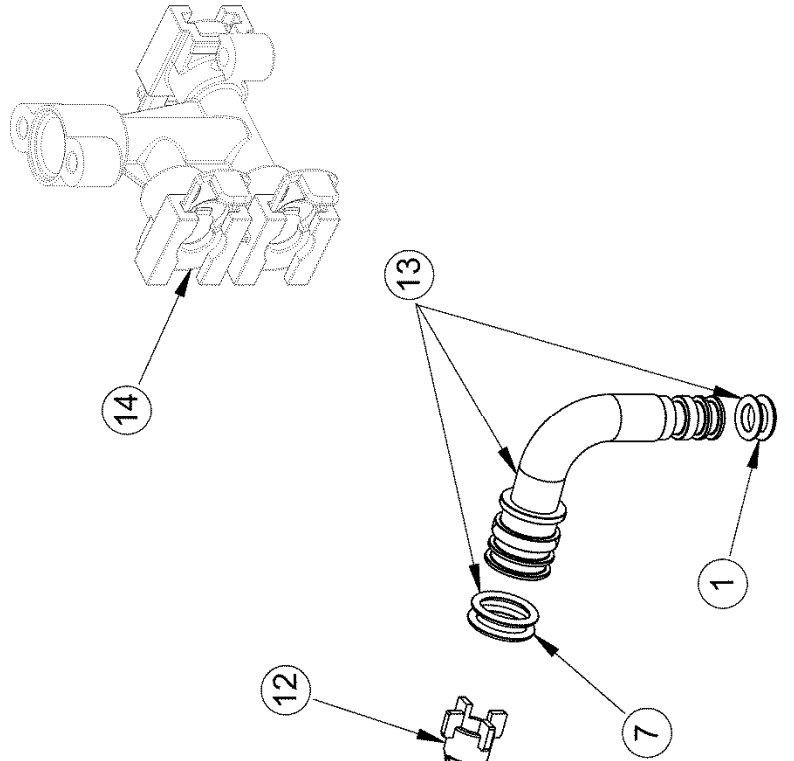

ITEM	PART NO	DESCRIPTION
1	330509	O-RING, .239 ID * .07 WALL
2	320042	SCREW, 8-16 * 3/8, PLASTITE, PPH
3	320029	STEM ASY, SHUTOFF W/O-RING
4	320045	O-RING, .362 ID * .103 WALL
5	320022	RETAINER, STEM
6	320023	WASHER, STEM, SHUTOFF
7	330510	O-RING, .426 ID * .07 WALL
8	784524	FITTING, 9/16 * 1/4 ML F, W/O-RINGS
9	330553	VALVE, SUB ASSY. * INCLUDES 2,3,5,8,9,10
10	706620	RETAINER CLIP, FITTING, 9/16
11	330552	FILTER, STRAINER/FLOW CONTROL
12	330556	CAP, FILTER SCREEN
13	784522	ELBOW, UNION, 3/8 DOLE X 9/16 DOLE
14	320025	RETAINER CLIP, FITTING, 3/8
15	320047	ORING, .114 ID * .07 WALL
16	706488	SCREW ASSY, ADJUSTMENT, TEA/LEMONADE
	706490	SCREW ASSY, ADJUSTMENT, COFFEE

PN 800460

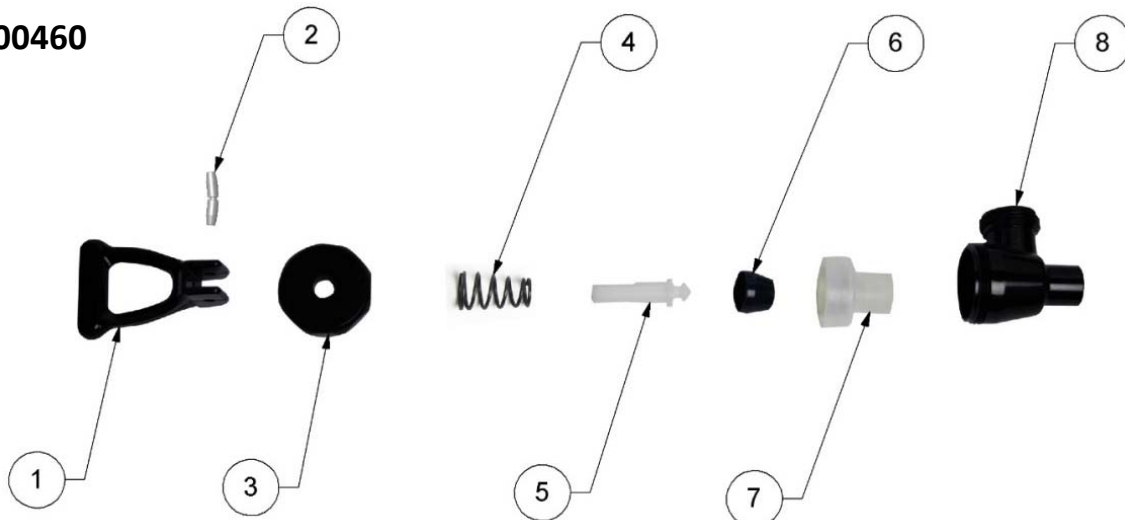

ITEM	PART NO	DESCRIPTION
1		HANDLE
2	120571	HANDLE PIN
3		BONNET
4		SPRING
5		PLUNGER
6		SPRING COVER
7	800013	SEAT CUP
8		FAUCET BODY

NEWCO PRODUCT WARRANTY

Applies to all equipment manufactured after 2/1/2017. This warranty supersedes all other previous warranties.

Newco warrants equipment manufactured by it for 1 year, parts and labor.

Accessories and Dispensers - 1 Year parts only.

Electronic Circuit and Control Boards - 3 years parts, 1 year labor.

Equipment manufactured by others and distributed by Newco - please see original equipment manufacturers warranty, Newco will follow.

These warranty periods run from the date of sale. Newco warrants that the equipment manufactured by it will be commercially free of defects in material and workmanship existing at the time of manufacture and appearing within the applicable warranty period. This warranty does not apply to any equipment, component or part that was not manufactured by Newco or that, in Newco's judgment, has been affected by misuse, neglect, alteration, improper installation or operation, relocation or reinstallation, improper maintenance or repair, incorrect voltage applied to the unit at any time, damage or casualty. This warranty does not apply to any equipment failures related to poor water quality, excessive lime and chlorine and non periodic cleaning and descaling. Warranty is null and void if muriatic or any other form of hydrochloric acid is used for cleaning or deliming. In addition, this warranty does not apply to replacement of items subject to normal use including but not limited to user replaceable parts such as faucet seat cups, sight gauge tubes, washers, o-rings, tubing, seals and gaskets.

This warranty is conditioned on the Buyer 1) giving Newco prompt notice of any claim to be made under this warranty by telephone at (800) 556-3926 or by writing to **3650 New Town Blvd, Saint Charles, MO 63301**; 2) if requested by Newco, shipping the defective equipment prepaid to an authorized Newco service location; and 3) receiving prior authorization from Newco that the defective equipment is under warranty.

THE FOREGOING WARRANTY IS EXCLUSIVE AND IS IN LIEU OF ANY OTHER WARRANTY, WRITTEN OR ORAL, EXPRESS OR IMPLIED, INCLUDING, BUT NOT LIMITED TO, ANY IMPLIED WARRANTY OF EITHER MERCHANTABILITY OR FITNESS FOR A PARTICULAR PURPOSE. The agents, dealers or employees of Newco are not authorized to make modifications to this warranty or to make additional warranties that are binding on Newco. Accordingly, statements by such individuals, whether oral or written, do not constitute warranties and should not be relied upon.

If Newco determines in its sole discretion that the equipment does not conform to the warranty, Newco, at its exclusive option while the equipment is under warranty, shall either 1) provide at no charge replacement parts and/or labor (during the applicable parts and labor warranty periods specified above) to repair the defective components, provided that this repair is done by a Newco Authorized Service Representative; or 2) shall replace the equipment or refund the purchase price for the equipment.

THE BUYER'S REMEDY AGAINST NEWCO FOR THE BREACH OF ANY OBLIGATION ARISING OUT OF THE SALE OF THIS EQUIPMENT, WHETHER DERIVED FROM WARRANTY OR OTHERWISE, SHALL BE LIMITED, AT NEWCO'S SOLE OPTION AS SPECIFIED HEREIN, TO REPAIR, REPLACEMENT OR REFUND.

In no event shall Newco be liable for any other damage or loss, including, but not limited to, lost profits, lost sales, loss of use of equipment, claims of Buyer's customers, cost of capital, cost of down time, cost of substitute equipment, facilities or services, or any other special, incidental or consequential damages.

