



Walker, Michigan, U.S.A. 49534-7564

**USER S OPERATING AND INSTRUCTION MANUAL**

**MODEL NC**

STEAM CONVECTION  
OVEN



690-NC2

**INDE**

<u>S</u> <u>D</u>	<u>D</u> <u>N</u>	<u>P</u> <u>N</u>
SAFETY INSTRUCTIONS -----	0690S20040 -----	1-1
DESCRIPTION/SPECIFICATIONS -----	0690S20041 -----	2-1
Description -----		2-1
Physical Specifications -----		2-1
INSTALLATION / SETUP -----	0690S20042 -----	3-1
Inspection -----		3-1
Location Selection -----		3-1
Sealing Oven to Mounting Surface -----		3-1
Oven Setup -----		3-2
Electrical Connection -----		3-2
Water Connection -----		3-4
Venting -----		3-5
Test Cycle -----		3-5
OPERATING INSTRUCTIONS -----	0690S20043 -----	4-1
Beginning Operation -----		4-1
The Keyboard and Displays -----		4-1
Idle Mode -----		4-2
Running an Automatic Program -----		4-2
Running Two Automatic Programs at the Same Time -----		4-3
Pre-Alarm -----		4-3
Running a Manual Program -----		4-3
Adjusting the Temperature -----		4-4
Adding Steam -----		4-5
Opening and Closing the Vent -----		4-5
Changing the Fan Setting -----		4-5
PROGRAMMING -----	0690S20044 -----	5-1
TROUBLESHOOTING -----	0690S20046 -----	6-1
Error Code Display -----		6-1
Solving Other Problems -----		6-2
Advanced Functions -----		6-5
Advanced Setup Mode (Re-calibration) -----		6-6
MAINTENANCE -----	0690S20045 -----	7-1
Cleaning -----		7-1
Lubrication -----		7-1
Removal and Replacement Guide -----		7-2
RECOMMENDED SPARE PARTS -----	0690S20047 -----	8-1





690-NC2

## SA ETY INSTRUCTIONS

### **WARNING**

**VARIOUS SAFETY DEVICES AND MET ODS O UARDIN A E BEEN PROVIDED ON THIS OVEN. IT IS ESSENTIAL O E RT ATT E O EN OPERATORS AND MAINTENANCE PERSONNEL OBSERVE THE FOLLOWING SAFETY PRECAUTIONS. IMPROPER INSTALLATION, MAINTENANCE OR OPERATION COULD CAUSE SERIOUS INJURY OR DEATH.**

1. Read this manual before attempting to operate your oven. Never allow an untrained person to operate or service this machine.
2. This oven must only be installed by qualified personnel. It also must be installed to the specifications of local plumbing and electrical codes. See the installation section of this manual for additional requirements.
3. Connect the oven to a properly grounded electrical supply that matches the requirements shown on the electrical specification plate and follow specifications of local electrical codes.
4. Disconnect and lock-out the oven from the power supply before cleaning or servicing.
5. Check and secure all guards before starting the oven.
6. Observe all caution and warning labels affixed to the oven.
7. Use only proper replacement parts.
8. Wear proper personal protective safety equipment.
9. Keep Hands away from the moving parts of this oven while it is in operation.
10. In addition to these general safety instructions, also follow the more specific safety instructions given for the different areas of the oven in the operating instructions.

### **WARNING**

**DO NOT USE OR OPERATE AN ORIGINALLY INTENDED PURPOSE**



690-NC2

## DESCRIPTION SPECIFICATIONS

### Description

The Oven is a stainless steel, electric, forced air, (convection), oven with steam injection capabilities. This oven offers consistent baking at all rack levels due to the careful positioning of the heating and air circulation systems.

In addition to the above, this oven also offers many other features. It is well insulated with a high quality asbestos free insulation. It is compact, attractive, quiet, and is easily maintained. Should electrical servicing ever be required the electrical components are readily accessible by removing the side or back panels.

The lighted, tempered glass door with its high temperature seal allows a full view of the trays in the oven during baking.

The oven computer allows you to bake two items at once which makes the oven more productive. It also has one of the fastest temperature recoveries on the market allowing the oven to be turned off during non-peak hours, thus saving energy.

The oven has many protective features such as not allowing heating of the elements when the door is open. Other features are resettable thermal overloads on the motors, a high-limit thermostat, and a magnetic circuit breaker on the control circuit.

The computer allows easy selection of baking programs. The programs combine precise control of the pre-heat temperature, baking temperature, time, pre-alarm, steam, and damper control. This allows precise baking by even inexperienced individuals.

### Physical Specifications

#### Electrical Options Available:

- 3 phase, 60 hz, 480VAC, 27 Amps.
- 3 phase, 60 hz, 208VAC, 48 Amps.
- 3 phase, 60 hz, 240VAC, 53 Amps.
- 3 phase, 50 hz, 375VAC, 22 Amps

#### Product Capacities:

The Standard oven will hold (8) 18" X 26" pastry baking trays these trays will be approximately 3-5/16 inches apart when in the oven.

6, 12 and 16 tray ovens are also available.

Rev. 8-12-99



690-NC2

Space Requirements:

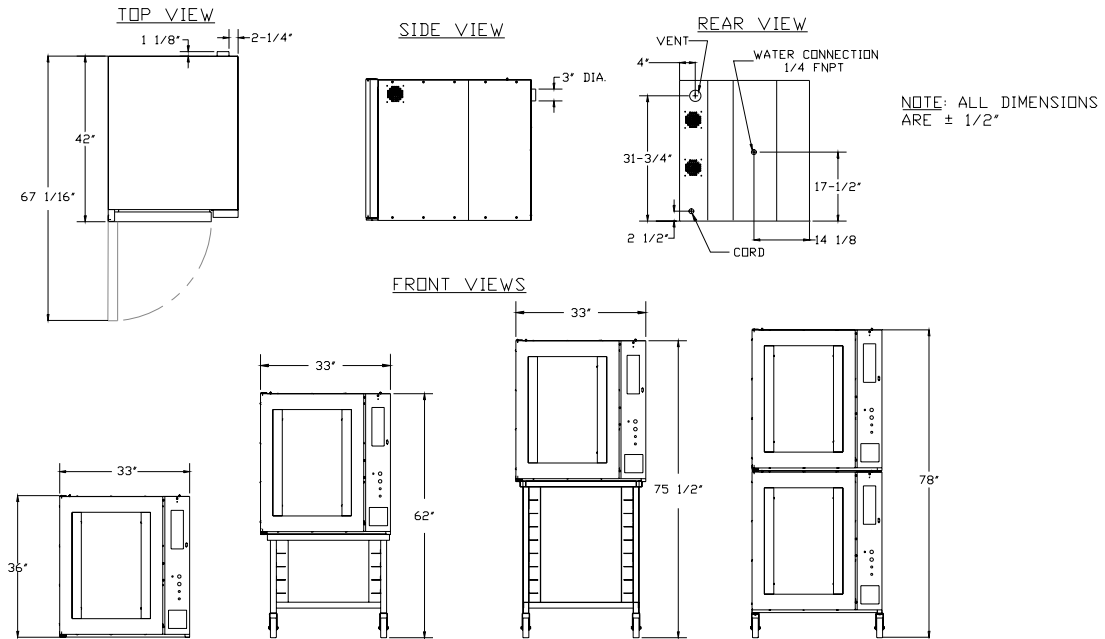

single: 42" Deep x 33" Wide x 35-3/4" high.  
single with short stand and casters: 62" high.  
single with tall stand and casters: 75-1/2"  
stacked ovens with casters: 78"

Clearance:

Left side = 2".

Right side = 12" without casters to have access to electrical components,  
2" with casters.

Back side = 4" to allow for water connections and venting.

Net Weight: Approximately 500 pounds.

Shipping Weight: Approximately 675 pounds.

Rev. 11-1-01



690-NC2

## INSTALLATION SETUP

### **CAUTION**

**TO MAINTAIN WARRANTY COVERAGE INSTALLATION MUST BE COMPLETED BY AN OLIVER PACKAGING EQUIPMENT AUTHORIZED SERVICE DEALER**

#### Inspection

Before accepting delivery inspect the carton and machine for damage. Note any damage found on the shipping documents. Remember shipping damage \_\_\_\_\_ covered by your warranty, and is the responsibility of the carrier. Also report the damage to the dealer from which the oven was purchased for further direction and assistance in filing a claim with the carrier.

#### Location Selection

Select a location where the oven will be used. The oven must be set on a flat level surface. It should have a grounded power supply of the same rating as shown on the nameplate located on the rear of the oven and this power supply must be capable of carrying the load that the oven will put on it (See "Electrical Connection" below). The oven must also be placed near both a water supply and an area where the oven can be properly vented (See "Water Connection" and "Venting" below).

Ovens with casters should be placed so that they have a minimum of two inches on each side and a minimum of four inches in the rear of the oven to provide for proper venting, water, and electrical connections.

Ovens without casters should be placed so that there is a minimum of two inches on all sides, except for the side with the electrical panel, (right side), which should have a minimum of twelve inches. The rear of an oven without casters should be a minimum of four inches away from adjacent surfaces to allow room for the electrical, water and venting connections.

#### Sealing Oven to Mounting Surface

### **CAUTION**

**MAINSURE THAT THE MOUNTING SURFACE IS ABLE TO SUPPORT THE WEIGHT OF THE OVEN WHICH IS APPROXIMATELY 100 POUNDS PLUS AN ADEQUATE SAFETY FACTOR BEFORE PLACING IT ON THE SURFACE**



690-NC2

The oven \_\_\_\_\_ sealed to the mounting surface to comply with local sanitation codes. For the purpose of sealing the unit a tube of NSF/FDA approved silicone sealant has been provided with your unit. Apply, to the surface that the oven will rest on, a continuous bead of sealant approximately 1/2 inch in from each of the four sides of the oven. After the oven has been placed over this bead apply a second generous continuous bead at the joint where the oven contacts the mounting surface thus totally sealing the bottom of the oven to that surface.

Oven Setup

Ovens may be mounted to a fixed surface, attached to an “Oliver” oven rack with casters or stacked. For associated mounting heights for the above options see figure 3.0 on page 2-2.

**CAUTION**

**USE CARE      ENE ER MO IN   O ENS MOUNTED ON RAC S AS T EY ARE  
TOP EA Y AND PRESENT A TIPPIN   A ARD**

Ovens attached to “Oliver” oven racks must be securely fixed to the rack with bolts. Stacked ovens should be setup as shown on page 2-2 being sure that the alignment pins on the top of the lower oven are securely positioned into the holes in the base of the upper oven.

After the Oven has been mounted to a surface, attached to a rack, or stacked, remove the shipping bracket, which secures the door. To remove the shipping bracket, remove the two screws from the top of the door with a screwdriver and open the door. Replace these screws and tighten securely. To remove the shipping bracket from the front of the oven liner, remove the two hex head screws with a wrench. The bracket and screws may be discarded. Replace the removed hex head screws with the two screws provided in a bag taped to the floor of the oven chamber and tighten securely.

Electrical Connection

**WARNING**

**T E O EN MUST BE CONNECTED TO A PROPERLY   ROUNDED ELECTRICAL  
SOURCE O T E SAME RATIN   AS T E MAC INE   AILURE COULD RESULT IN  
AN ELECTRICAL S OC   IC   MAY CAUSE IN URY OR DEAT**

**WARNING**

**ALL   IRIN   AND ELECTRICAL REPAIRS S OULD BE DONE BY A   UALI IED  
ELECTRICIAN   AILURE TO DO SO MAY CAUSE SERIOUS IN URY OR DEAT**



690-NC2

## **CAUTION**

**SPECIAL EASY DUTY ELECTRICAL SERVICES AND ALL DISCONNECTS  
MUST BE PROVIDED FOR SAFE OPERATION OF THE OVEN**

### Electrical Connection (continued)

The following service requirements are recommended, dependent on the voltage of the unit you have purchased. Your oven's requirements can be found on the nameplate attached to its rear surface.

For voltages other than those shown below please contact the factory. Check the voltage at the disconnect before proceeding to the next step.

480 Volts = 30 Amp service  
375 Volts = 30 Amp service  
240 Volts = 60 Amp service  
208 Volts = 60 Amp service

The oven is shipped from the factory with a power cord, which does not include a plug. The power cord should be wired to a disconnect enclosure which is accessible from the oven work area, leave at least two feet of slack so that access can be gained to the oven's back and right side. A plug may be used between the disconnect enclosure and the oven instead of hard wiring as described above. This makes sliding the oven out for service more convenient. Whatever method is used the oven should be wired in a manner which would conform to the U.S. "National Electric Code".

## **CAUTION**

**FANS MUST ROTATE IN THE CLOCKWISE DIRECTION OR PROPER AIR FLOW  
IMPROPER DIRECTION MAY CAUSE UNEVEN BAKES AND LONGER BAKING TIMES**

Check fan rotation for clockwise direction. After the oven has been "Set Up" and connected to the electrical service do the following to check the rotation of the fans. At the lower right hand corner of the front surface of the oven you will find a small rectangular panel held in place with two thumb screws. Removing these screws and the panel they secure will expose the "Manual" controls of the oven. Use the following sequence to start the oven to check fan rotation direction:

- Switch the oven to manual mode.
- Turn the main power switch on, (green button above the manual controls). The oven should start and fan rotation can now be checked.
- Once complete, turn the main power switch off, (red button above the manual controls), return the oven to automatic mode and replace the cover.

If the rotation is incorrect remove and interchange any two of the three incoming power leads (red, white and black), at the plug or disconnect enclosure and retest.



690-NC2

### Water Connection

All water connections must comply with the basic plumbing code of the Building Officials and Code Service Sanitation Manual of the Food and Drug Administration (FDA)

## **CAUTION**

**WATER PRESSURES GREATER THAN RECOMMENDED CAN CAUSE EXCESS WATER TO ENTER THE OVEN CAUSING WATER TO LEAK AT THE DOOR AND ALSO CAUSE THE TEMPERATURE TO DROP SEVERELY AFFECTING THE BAKE USE A PRESSURE REGULATOR TO REGULATE THE PRESSURE**

The oven must be connected to a water supply to enable the oven to produce steam for baking. As shipped from the factory the oven will have a solenoid valve at the back center of the oven, (See figure 3.0 page 2-2). This valve has an internal 1/4" NPT thread for connection. Water pressure should be a maximum of 60 to 70 PSI and the water must clean. Use a pressure regulator and a water strainer/filter to meet these guidelines. Before making the water connection flush all lines and install the regulator and filter. Remember solenoid failure and related problems caused by dirt may not be covered by your warranty.

## **NOTE**

**WATER LEAKS MINERAL DEPOSITS ON GLASS AND OTHER SURFACES WHICH DETRACT FROM OVEN APPEARANCE**

The solenoid valve can be checked after "Set Up" and the "Electrical and Water Connection" has been completed. At the lower right hand corner of the front surface of the oven you will find a small rectangular panel held in place with two thumb screws. Removing these screws and the panel they secure will expose the "Manual" controls of the oven. Use the following sequence to start the oven to check solenoid operation.

- Switch the oven to manual mode.
- Turn the main power switch on, (green button above the manual controls).
- Press the steam button briefly and release, water should spray from each of the spray nozzles. Adjust the spray nozzles if required so that they are vertical and spray directly into the fans.
- Once complete, turn the main power switch off, (red button above the manual controls), return the oven to automatic mode and replace the cover.

### Venting

On the rear side of the oven near the top is a 3" diameter exhaust vent protruding approximately 3/4" from the oven. Vent the exhaust (hot air and steam) to the outside by connecting to this vent.



690-NC2

## **WARNING**

**HOT STEAM CAN CAUSE SEVERE BURNS AND DAMAGE TO THE SENSITIVE ELECTRONICS. VENT STEAM TO OUTSIDE TO AVOID INJURIES AND DAMAGE.**

### Test Cycle (done manually without computer)

After completing the Set Up, Electrical and Water connections, and Venting, you may wish to run the oven through a test cycle to verify that everything is ready. At the lower right hand corner of the front surface of the oven you will find a small rectangular panel held in place with two thumb screws. Removing these screws and the panel they secure will expose the "Manual" controls of the oven. Use the following sequence to run the oven through a test cycle.

- Switch the oven to manual mode.
- Set the Temperature Control to a desired temperature such as 400 degrees.
- Turn the main power switch on, (green button above the manual controls).
- Once the oven reaches the set temperature press the steam button briefly and release, (a second or two), water should spray from each of the spray nozzles directly into the fans which will spread the water onto the heating elements causing steam. Under normal conditions SOME STEAM WILL ESCAPE THROUGH THE FRONT DOOR GASKET.
- Once complete, turn the main power switch off, (red button above the manual controls), return the oven to automatic mode and replace the cover.



690-NC2



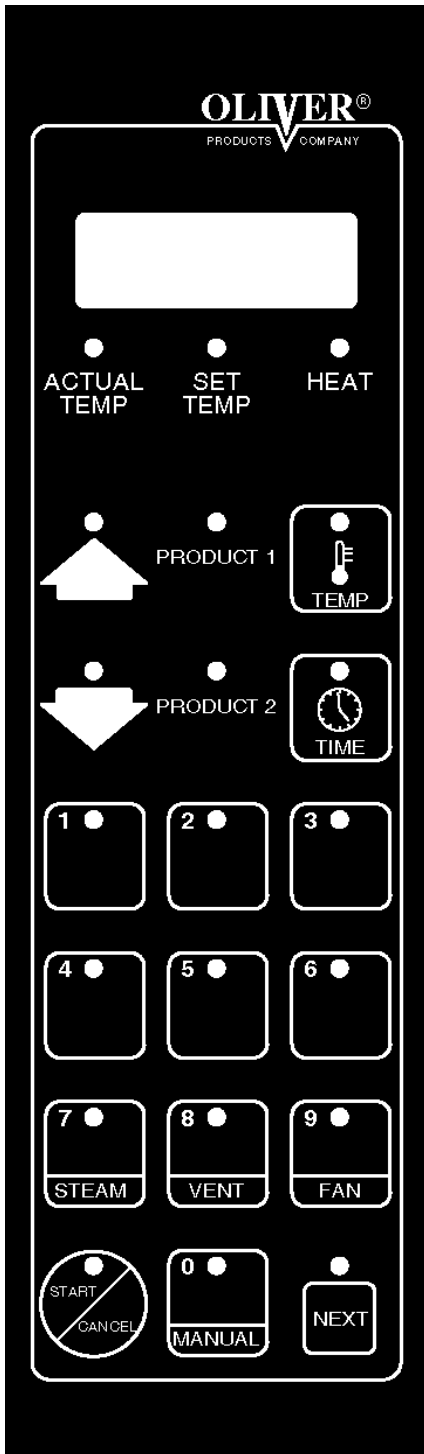



## OPERATING INSTRUCTIONS



### Beginning Operation

First turn the oven on by pressing the black 'Start/ Reset' button below the keyboard and display. The computer will then check the oven and itself for any faults. Then the display will show the current mode which is idle **Idle** the preset initial temperature is 250 °F.

### The Keyboard and Displays

- Press the temp. key  to toggle the display between Time, Actual Temp., Set Temp., and Idle.
- The display LED's will light for actual and set temperature.
- The Heat LED will light when the heating elements are on.
- Use the up and down keys   to add and subtract time in whole minute increments.
-  The time key is used when a bake is running. Press this key to display the time remaining. During 2 product baking pressing this key will briefly display the product with the most time remaining.
-  The temp key will change the display between set point, set temp., and time remaining.
-  The Start/Cancel key is pressed to start and cancel various operations.
-  The next key is used in programming.
- Other detailed key descriptions are explained in the next sections.



690-NC2







### Idle Mode

From Idle mode you can:

- Run an automatic program.
- Run a manual program.
- Adjust the temperature.
- add steam.
- open and close the vent.
- change the fan setting.

### Running an Automatic Program

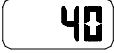
1. From Idle mode  enter the program number (01 - 40) using the keypad
2. Wait 3 seconds or press the start key to begin preheat stage.
3. Wait for oven to reach set temperature. The display will show lo or hi and the menu number. When the set point is reached the buzzer will sound and the display will show ready .
4. Put product into the oven.
5. Close door, bake begins.
6. Pre-Alarm #1  will sound if programmed, press  to cancel the alarm. For more details see the Pre-Alarm section.
7. Alarm will sound when bake is finished and display will show , and the program number .

Open the door to end the program, this will hold the current bake temperature, add time if required by pressing the up button. **OR**

Press cancel  to end the bake and return the holding temperature to 250 °F.





690-NC2

### Running two Automatic Programs at the Same Time

If two programs are compatible they may be run at the same time. They must both be single stage menus with identical temperatures. While the program is running (Product 1 LED will be lit) enter the second program number (01-40) and hit start. Now both product LED's will be lit, the one with the shortest time will have a flashing LED and the time remaining will be displayed. To briefly display the time of the other product press

the Time key .



### Pre-Alarm

The pre-alarm will go off during the bake as programmed. The alarm will sound and the display will show  (the 1 is for product-1, product-2 pre-alarm displays ) press cancel or open the door to clear the alarm.



For advanced users: *While the pre-alarm is displayed it is possible to add time to it. Do this by pressing the up key. Press the up key once for each minute. Then wait three seconds or press the start key. Example: by adding 2 minutes to the pre-alarm, another pre-alarm will sound in two minutes. It is then possible to add time again and again.*

*If the alarm is cleared by opening the door it is still possible to add time. However if the door is then shut and the up key isn't pressed within three seconds, the pre-alarm will be cleared and it will not be possible to add time.*

### Running a manual program

From idle mode  press the manual key  then press start .

Now enter the desired temperature by using the numeric keypad or the arrow keys to scroll.

Press the next key  to advance. Display will show  which prompts you to enter the time.

Using the numeric keypad enter the time in minutes and seconds.

E R

Display Shows



Press Button(s)...





690-NC2



and

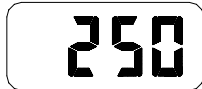

Countdown begins.

### Adjusting the Temperature

The temperature can be changed while in manual or idle mode. Here is an example of how to change the temperature from 350 to 380.

Display Shows

Press Button(s)...

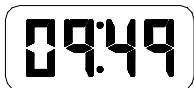

or



Actual temp,

Press the temp key again





690-NC2



Set temp.

Use  and  to scroll to 380.



Press  to go back to 'Time or Idle'.

### Adding Steam

It is possible to inject steam at any time the door is closed by pressing and holding the 7/steam button .

### Opening and Closing the Vent

It is possible to toggle the vent open and closed by pressing the 8/vent key . This will not work when a program is running. Use this feature to vent some of the steam out of the oven before opening the door. However, some hot steam will always remain.

## **CAUTION**



**SUPER HEATED STEAM IS INVISIBLE AND IS POSSIBLY PRESENT IN THE OVEN  
THIS STEAM MAY BURN SKIN STAND AS FAR AS POSSIBLE AWAY FROM  
OVEN WHEN OPENING THE DOOR THEN PROCEED WITH CAUTION**





### Changing the Fan Setting

The fan cannot be changed when a program is running.



690-NC2

In manual mode the fans can be set to high  or low  by pressing the 9/fan key .

In Idle mode the fans can be set to high , low , or cool down  using the 9/fan key .

*Cool down allows the oven chamber to quickly cool down by keeping the blowers running while the door is open.*













*The low fan setting is helpful for high sugar product.*



690-NC2

## PRO RAMMIN

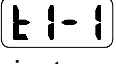
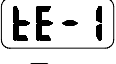
The following are instructions for editing and creating a menu program.

1. Enter the Program Mode by pressing the up and down keys   simultaneously for 5 seconds.
2. Display shows  for MENU.
3. Key in the menu number you want to program (01-40), or use the up and down keys to scroll.  
Programs 01-20 can hold two stages.  
Programs 21-40 hold one stage
4. Press the 'next' key  to edit/program the first parameter of the menu.
5. Display will show  for P . Use the up and down keys or the keypad to enter the preheat temperature. Press the next key  to advance.
6. Display will show  for T C . Use the up and down keys   to adjust temperature Compensation to on or off. Press the next key  to advance.
7. Display will show  for . Use the up and down keys to adjust the steam time between 0-30, C2, C3, and C4. C2 produces two cycles of 15 second steam. C3 produces three cycles etc. Press 'next' key to advance.
8. Display will show  for . Use up and down keys or keypad to enter the time in minutes and seconds. Press 'next' key to advance.  
Example: Enter 1200 for twelve minutes and zero seconds.
9. Display will show  for T . Use up and down keys or keypad to enter the Temperature between 250°F and 500°F. Press the 'next' key to advance.
10. Display will show  for . Use up and down keys to scroll between Hi and Lo fans. Press 'next' key to advance.



690-NC2

11. Display will show **E1-2** for . Stage 2 only works for menus 01-20 (For menus 21-40 skip to the Pre-alarm). Use up and down keys or keypad to enter the time in whole minutes. Entering 0 will eliminate stage 2 and skip you past the rest of the stage 2 parameters. Press 'next' key to advance.
12. Display will show **TE-2** for **T** . Use up and down keys or keypad to enter the Temperature. Press the 'next' key to advance.
13. Display will show **FAn** for . Use up and down keys to scroll between Hi and Lo fans. Press 'next' key to advance. Best results are achieved with the fans on HI.
14. Display will show **PrE** for **P A** . Use the up and down keys to select the Pre-Alarm in whole minutes (0 to 30). Example: A pre alarm value of 1 will sound an alarm 1 minute before the time expires. Press 'next' key to advance.
15. Display will show **UEnt** for . Use the up and down keys to scroll closed, open or 1-14 minutes. Venting example: A vent time of one minute will make the vent open one minute before the end of the menu program. Press 'next' key to complete program and return to the menu prompt.
16. Enter the next menu number to be programmed or press cancel to leave programming mode.



690-NC2  
**TROUBLES OOTIN**

**WARNING**

**TROUBLE S OOTIN O ELECTRICAL E UIPMENTS OULD BE PER ORMED  
BY UALI IED PERSONNEL ONLY ELECTRICAL POTENTIAL IS REAT  
ENOU TO CAUSE IN URY OR DEAT**

Error Code Display

The error code is visible in the display. The list below outlines the standard error codes associated with this unit. They are designed to isolate specific problem areas and aid in troubleshooting your control.

P	P C	S
<b>E</b> (ROM) Checksum error	Internal ROM is defective	Turn Off and then Restart.
<b>E</b> (RAM) Checksum error	Internal RAM is defective	Turn Off and then Restart.
<b>E</b> Eprom Error	<ul style="list-style-type: none"> <li>•Power loss while storing data.</li> <li>•Eprom has been changed.</li> </ul>	Turn Off and then Restart. or Replace Eprom
<b>E</b> Zone 1/Top probe A/D underflow error	<ul style="list-style-type: none"> <li>•Incorrect sensor type.</li> <li>•Measuring temperature outside the sensor range.</li> </ul>	Check sensor.
<b>E</b> Zone 1/Top probe overflow error	Open sensor	Check for an open sensor.
<b>E</b> Zone 2/Bottom probe A/D underflow error	<ul style="list-style-type: none"> <li>•Incorrect sensor type.</li> <li>•Measuring temperature outside the sensor range.</li> </ul>	Check sensor.
<b>E</b> Zone 2/Bottom probe overflow error	Open sensor	Check for an open sensor.
<b>E</b> Stack overflow error	Microprocessor error	Turn Off and then Restart.
<b>E</b> Zone 1/Top probe error	Open RTD probe	Check for an open probe
<b>E</b> Zone 1/Top probe shorted	Probe is out of range	Check probe for short. Should be greater than 90 ohms.



690-NC2

**E C D**

<b>P</b>	<b>P C</b>	<b>S</b>
<b>E</b> Zone 2/Bottom probe open sensor	Open sensor	Check for an open probe.
<b>E</b> Zone 2/Bottom probe shorted sensor	Probe is out of range.	Check probe for short. Should be greater than 90 ohms.
<b>E</b> Zone 1 loop error	<ul style="list-style-type: none"> <li>•Faulty heater</li> <li>•Shorted sensor</li> <li>•Bad heater contactor</li> </ul>	<ul style="list-style-type: none"> <li>•Check heater elements</li> <li>•Check sensor probe</li> <li>•Check switching device</li> </ul>
<b>E</b> Zone 2 loop error	<ul style="list-style-type: none"> <li>•Faulty heater</li> <li>•Shorted sensor</li> <li>•Bad heater contactor</li> </ul>	<ul style="list-style-type: none"> <li>•Check heater elements</li> <li>•Check sensor probe</li> <li>•Check switching device</li> </ul>

**CAUTION**

**BE CAREFUL WHEN OPERATING AS BEEN RECENTLY USED  
ALLOW SUFFICIENT TIME FOR IT TO COOL TO PREVENT BURNS**

**SOLUTION TO OTHER PROBLEMS**

*No Power.*

- The machine is not plugged in.
- There is no power available at the outlet/disconnect
- The circuit breaker has tripped. Reset by pressing the switch so that it is flush with the front panel. (Control panel only)
- A fuse has blown.
- The transformer has failed. (Control panel only)

*No Heat or Oven Heats Slowly*

A cooled dry empty oven can be heated from room temperature to 300 °F in four to six minutes. If the oven is not meeting this specification, check the following.

- Check the fuses
- Check the two contactors.

*No Heat or Oven Heats Slowly (Continued)*



## 690-NC2

- Check heater bank continuity.
- The fault/high limit lamp is on, see the trouble shooting suggestions for this area below.

### *The Fault/High Limit Lamp Is On*

- Motor has overheated. (The blower motors are equipped with an internal thermal switch). Turn the oven off and try to restart after the motor has cooled.  
Possible causes:
  - 1.) The motor bearing or winding has failed.
  - 2.) Something is binding the motors or blower fans.
  - 3.) The rear of the oven lacks sufficient clearance to allow proper air circulation.
- Oven temperature is too high. (Your oven comes with a high temperature limit switch set at approx. 575 °F. This switch will reset when the oven has cooled.)
- A power interruption has occurred

### *No Steam*

- The water line to the oven may not have been turned on or someone has turned it off.
- Your water line filter may be plugged or need servicing.
- The water solenoid valve may be dirty and stuck shut.
- The water solenoid valve may have failed.
- The water pressure may be too low, the oven requires between 60-70 psi.
- The water spray nozzles inside the oven chamber which spray water into each of the blower fans may be plugged, remove the nozzle assembly and clean.
- The nozzle assembly, which sprays water into the blower fans, is not vertical and is not spraying the water directly into the fans as it should.

### *The Steam Will Not Stop /or Continuous Steam*

It is normal for water to drip from the spray nozzles for several seconds after steaming, however if it continues to drip or run, check the following.

- The water solenoid valve may be dirty and stuck open.
- The water solenoid valve may have failed.



690-NC2

### *Steam Is Leaking From the Door*

It is normal for some steam to escape from the door during the steaming operation, however, if excessive amounts escape you should check the following.

- The door seal may be damaged.
- The door may not be latching properly.

### *The Door Will Not Close*

- Slamming the door too hard can cause it to bounce off of the seals, not allowing the door time enough to latch properly.
- Sometimes after replacement of the door seals the strike may need to be re-shimmed to generate the proper seal. Remember only a single shim should be used, order shim kit number 690-0148K when replacing seals.
- Check for a worn or broken latch or strike.
- The Latch mounted to the door may be too far away from the strike. It may be adjusted left to right.

### *One or both of The Blower Fans Will Not Run*

- The oven liner may be rubbing on the fan preventing its rotation.
- A motor fuse may need to be replaced.
- The door switch may not be working.
- The fault/high limit lamp is on, see the trouble shooting suggestions for this area above.
- The high limit switch has failed.
- A blower fan motor may have failed.

### *The Blower Fans Run Continuously*

Other than when the oven is in "Cool Down" mode the blower fans should not run when the door is open. Things which may make this happen are:

- A failure of the door switch.
- A blower fan motor contactor failure.



690-NC2

### *The Oven Is Overheating*

This may be a normal condition experienced when the oven is empty. Normally the oven's program will attempt to correct temperature based on a full oven's requirements.

- A heat contactor may have failed.
- There is an error in your program, if it is a new program check that the temperature was entered correctly.
- The oven may be out of calibration. See the Advanced setup Mode on page 6-6 to find out how to re-calibrate the oven.

### *The Oven is Baking Unevenly*

- A blower fan or fans are turning in the wrong direction.
- The oven may be out of calibration. See the Advanced setup Mode on page 6-6 to find out how to re-calibrate the oven.
- The vent damper may be stuck open.
- One or more of the blower fans may not be turning. See page 6-4 possible causes for this
- You may have low voltage at the power source.

### Advanced Functions

Checking the software version and temperatures.

Press       

Advance through the parameters by using the  key. The parameters are as follows.

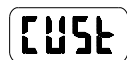

Customer number should be 48.



Software Revision should be 5 or higher.



Zone 1 temperature shows the temperature reading of the top probe without offset.



690-NC2

Continued

### Advanced Functions (Continued)

**Zone2**

Zone 2 temperature shows the temperature reading of the top probe without offset.

### Advanced Setup Mode (Re-calibration)

To change offset temperature or run on only 1 probe enter the following key sequence.

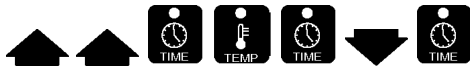

Advance through all parameters by using the **NEXT** key. Do not change any of the parameters except the ones listed below. This is only required after a probe fails. The parameters are as follows.

**PrOb**

Default is 2, 1 can be used when only the top probe is working.

**CAL**

and

**CAL2**

adjust with the up and down key for temperature offset for probe 1 and 2.



690-NC2  
**MAINTENANCE**

**WARNING**

**NE ER ATTEMPT TO CLEAN OR SER ICE T IS O EN UNTIL IT AS BEEN DISCONNECTED ROM T E PO ER SUPPLY AND IS COOL TO T E TOUC**

**NOTE**

**REMEMBER A CLEAN O EN ILL LAST LON ER AND OR BETTER**

Cleaning

The outside of the oven should be cleaned daily by wiping it with a clean damp cloth or by using any suitable stainless steel cleaner. A solution made up of a mild detergent with water will normally be sufficient for routine cleaning of the interior of the oven. When finished dry the surfaces with a clean cloth.

The glass door should be cleaned daily using normal glass cleaners.

For more difficult cleaning jobs such as where there are burned on or greasy deposits, or heat tint, you should use an abrasive pad. Remember for best results always keep the stainless steel shiny.

To simplify major cleanings the inner liner may be removed by first removing the nozzle assembly in the back of the oven with an open end wrench, and then by removing the eight slotted head screws which secure the liner. Six of these screws are in the front of the oven while two additional screws are on the rear panel adjacent to the nozzle assembly.

Clean the rear fan cover frequently to insure air circulation through the electrical compartment. This will lessen the possibility of heat related electrical problems.

The heating elements themselves normally do not require cleaning.

Lubrication

Occasionally put a few drops of oil on the pivot points of the door. No other items requires lubrication.

**CAUTION**

**NE ER LUBRICATE T E MOTORS**



690-NC2

## Removal and Replacement Guide

### *Removing the Inner Liner:*

- First remove the nozzle assembly in the back of the oven.
- Remove the eight slotted head screws which secure the liner. Six of these screws are in the front of the oven while two additional screws are on the rear panel adjacent to the nozzle assembly.
- The liner can now be removed from the oven.

### *Replacing the Fan or Fan Motor:*

## **WARNING**

**NEVER ATTEMPT TO CLEAN OR SERVICET HIS OVEN UNTIL IT HAS BEEN DISCONNECTED FROM THE POWER SUPPLY AND IS COOL TO THE TOUCH.**

- First remove the inner liner as described above.
- Next, use a wrench to remove the hex head bolt in the end of the motor shaft which secures the fan.
- Loosen the two set screws in the hub of the fan.
- Always use a puller to remove the fan from the motor shaft to protect the bearings in the motor.
- Disconnect wires from motor, wiring connections are in the wiring box on the motor.
- Take off the four nuts and remove the motor.
- Re-install the fans and/or motors by reversing the disassembly procedures.

### *Changing a Bank of Heating Elements.*

- Remove the inner liner as described above.
- Remove the fan(s) as described above.
- Remove the electrical rear side panel by removing the 9 slotted head screws which secure the cover.
- Remove the wires from the ends of the affected bank of heating elements. Make sure they are marked so that they can be returned to the new bank of elements easily.



690-NC2

### *Changing a Bank of Heating Elements (Continued).*

- Remove the four hex head screws which secure the bank to the housing and remove the bank of elements.
- The interior surface where the bank of elements were previously attached should be cleaned completely of any remaining sealant.
- A new bank of elements must be sealed to the housing using a NSF/FDA approved silicone sealant.
- Finish installing the new elements by reversing the above disassembly procedures.

### *Replacing the Exterior Door Gasket*

- Remove the 18 screws which hold the gasket retainers on.
- Remove the gasket.
- The sheet metal surface of the door where the gasket was attached and the retainers should be cleaned completely of any remaining sealant.
- Replace the gasket retainers but leave the screws loose.
- Start replacing the gasket on the hinge side of the door beginning about 1-1/2" above the spot where the two retainers meet. Slide the gasket between the retainer and the door surface making sure it is seated completely especially in the corners.
- Tighten the gasket retainer screws as you go.
- Completely seal the inside and outside edges of the gasket using a NSF/FDA approved silicone sealant. (Run a bead underneath the outside edge of the gasket as well as along the edge)
- Allow sealant to dry before closing the door or operating the oven, (approximately four to five hours).

### *Replacing the Interior Door Gasket*

- Remove the 14 screws securing the door panel (It has the exterior gasket fastened to it).
- Lay the panel down and remove the gasket from the glass and metal frame.

Rev. 4-28-2000



690-NC2

#### Replacing the Interior Door Gasket (Continued)

- Replace gasket and use a NSF/FDA approve sealant between the metal and gasket. and gasket end to end.
- Set down door frame, rounded gasket side up and run a bead of NSF/FDA approved sealant around top edge of entire gasket.
- Place glass on top of gasket. This will seal the gasket to the glass.
- Allow sealant to dry, (approximately four to five hours).
- Replace door panel, clamp the front and back door panels together before tightening the screws.

#### *Changing an Electrical Component*

### **WARNING**

**NEVER ATTEMPT TO SERVICET HIS O EN UNTIL IT HAS BEEN DISCONNECTED FROM THE POWER SUPPLY ALL ELECTRICAL WORK MUST BE DONE BY A QUALIFIED ELECTRICIAN**

- Remove the front side panel which is located on the control side.
- After identifying the component which needs to be replaced remove its wires after marking them for ease of replacement.
- Remove the component.
- Re-install the component by reversing the removal procedures.

Rev. 4-28-2000



690-NC2

**RECOMMENDED SPARE PARTS**

<u>PART NUMBER</u>	<u>PART DESCRIPTION</u>	<u>NO RE D</u>
5725-9626	Fuse-FRN 8 (208/240V)	2
5725-9442	Fuse-FNQR 4 (375/480V)	2
5725-9634	Fuse-FRN 30 (208/240V)	6
5725-9066	Fuse-KTKR-15 (375/480V)	6
5748-6718	Valve-Solenoid 2-Way	1
5760-3194	Transformer (240/480V)	1
5760-3195	Transformer (208/375V)	1
5749-8021	Relay-Power 3-Pole, 25A	3
5708-6808	Block-Contact 1NC	1
5708-6809	Block-Contact 1NO	1
5708-7806	Pushbutton-Green (On)	1
5708-7805	Pushbutton-Red (Off)	1
5757-8819	Switch-Magnetic Proximity Door	1
5757-4125	Breaker-Circuit 2.5A	1
5737-2010	Lamp-Fluorescent	1
5911-9030	Latch-Body	1
0690-0149	Strike-Door	1
6542-0003	Glass-Door	1
6904-6062	Gasket-Door Interior and Exterior	17 ft
5757-8083	Switch-Limit	2
6310-0003	Motor-Gear 1/110 h.p. (For Vent)	1

For Service Parts Call Oliver Products @ 800-253-3893

(continued)

Rev. 2-27-02



690-NC2

RECOMMENDED SPARE PARTS (continued)

<u>PART NUMBER</u>	<u>PART DESCRIPTION</u>	<u>NO RE D</u>
0690-0004	Motor-Blower (208/240/480V)	2
0690-0004-2	Motor-Blower (375V only)	2
0690-0045	Wheel-Blower	2
5712-0655	Sensor-RTD 100 Ohm	2
5712-0029	Coupling-RTD Sensor	2
5704-5011	Cable-Computer/Interface 9 Pin Mate-n-Lock	1
5704-5012	Cable-Computer/Interface 12 Pin Mate-n-Lock	1
5712-3261	Interface-Watlow Compatible	1
5712-3267	Computer-Oliver/Watlow	1
5730-2655	Heater-10KW	2
5757-9710	Switch-Thermal Surface Mount (Hi Limit)	1
6310-5027	Fan-Axial 3000 RPM (Cooling Fan)	2

For Service Parts Call Oliver Products @ 800-253-3893

Rev. 10-22-2003



690-NC2

### ELECTRICAL SUB PANEL

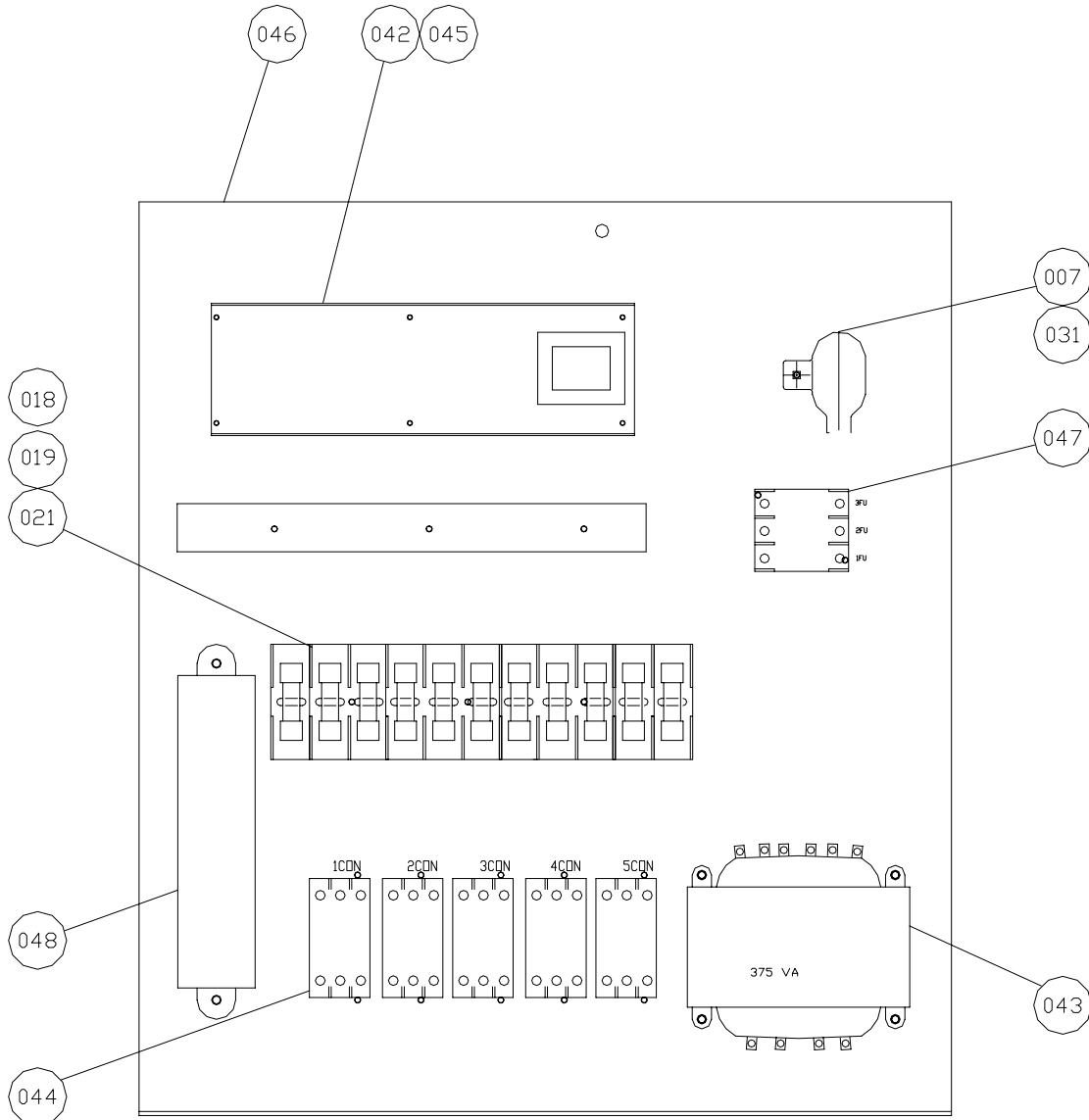

Rev 2-27-09



690-NC2

**ELECTRICAL SUB PANEL PARTS LIST**

<b><u>ITEM NO</u></b>	<b><u>PART DESCRIPTION</u></b>	<b><u>PART NUMBER</u></b>
007	KIT-CAPACITOR MTG.	5704-6530
018	FUSE-FNQR 4 (375/480V)	5725-9442
	FUSE-FRN 8 (208/240V)	5725-9626
019	FUSE-KTKR 15 (375/480V)	5725-9066
	FUSE-FRN 30 (208/240V)	5725-9634
021	BLOCK-FUSE CLASS CC (375/480V)	5726-1006
	BLOCK-FUSE CLASS CC (208/240V)	5726-1080
031	CAPACITOR	5704-6199
042	INTERFACE-WATLOW COMPATIBLE	5712-3261
043	TRANSFORMER-MULTI-TAPS (all models)	5760-3196
	TRANSFORMER-208/380V OVENS ONLY	5760-3195
	TRANSFORMER-240/480V OVENS ONLY	5760-3194
044	RELAY-POWER 3 POLE 25A	5749-8021
045	SPACER-NYLON 1/2"	5767-5705
046	SUBPANEL-ELECTRICAL	0690-0039-6
047	BLOCK-TERMINAL 0-14 GA	5770-7463
048	BALLAST-DOOR LAMP	5702-2000

FOR SERVICE PARTS CALL OLIVER PRODUCTS @ 800-253-3893

Rev 2-27-09



690-NC2

**RONT PANEL**

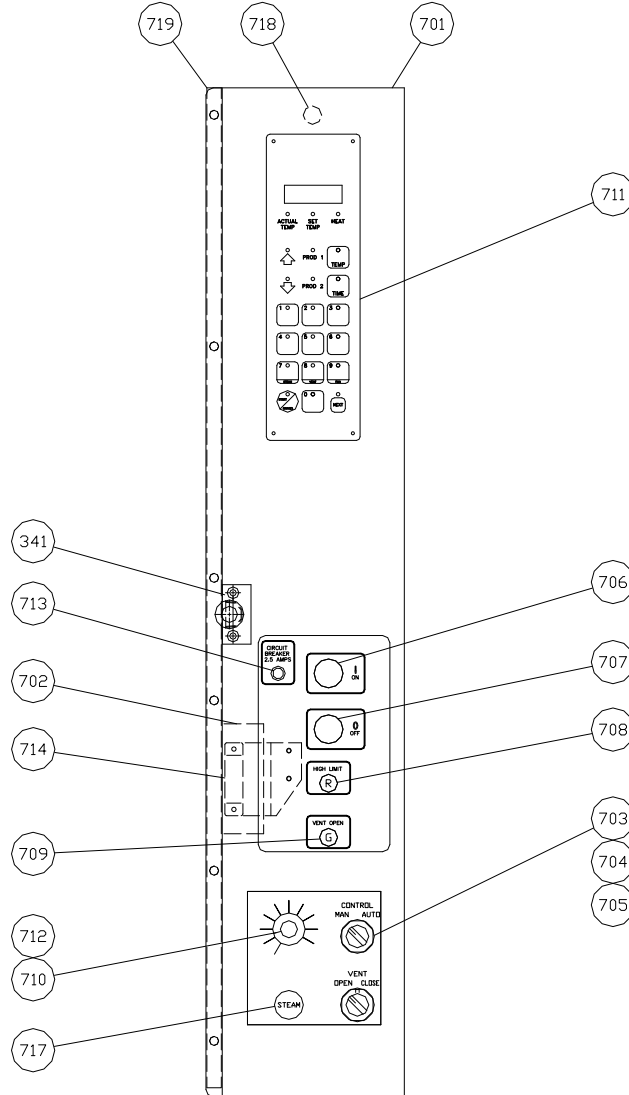

Revised 12/10/2012



690-NC2

**FRONT PANEL PARTS LIST**

<b>ITEM NO</b>	<b>PART DESCRIPTION</b>	<b>PART NUMBER</b>
341	STRIKE-LATCH	0690-0149
701	PANEL-FRONT CONTROL	0690-0034-2
702	BRACKET-PROX. SWITCH	0690-0042
703	SWITCH-2 POSITION MAINTAINED KNOB	5708-6522
704	BLOCK-CONTACT 1NC	5708-6808
705	BLOCK-CONTACT 1NO	5708-6809
706	PUSHBUTTON-GREEN	5708-7806
707	PUSHBUTTON-RED	5708-7805
708	LIGHT-PILOT 1/2+SNAP-IN RED	5709-0009
709	LIGHT-PILOT 1/2+SNAP-IN GREEN	5709-0011
710	CONTROL-TEMPERATURE	5712-0015
711	COMPUTER-16 KEY	5712-3267
712	KNOB	5736-4005
713	BREAKER-CIRCUIT 2.5A MAGNETIC	5757-4125
714	SWITCH-MAGNETIC PROXIMITY DOOR	5757-8819
717	PUSHBUTTON-+STEAM+	5708-7801
718	BUZZER	5700-6051
719	STRIP-INSULATOR	0690-0155

**NOTE**

**T H E R E M A I N I N P A N E L S A N D C O V E R S A R E S O N O T I N T H E L I S T B E L O W  
B U T A R E N O T S O N O N A N Y O T H E R D R A W I N G S I N T H I S M A N U A L**

<b>ITEM NO</b>	<b>PART DESCRIPTION</b>	<b>PART NUMBER</b>
050	PANEL-REAR FAN (375/460V)	0690-0038-101
	PANEL-REAR FAN (208/240V)	0690-0038-102
101	COVER-TOP	0690-0001-002
102	COVER-HINGE SIDE	0690-0002
105	COVER-ASSY-RECESS POCKET	0690-0074K
108	COVER-ELECTRICAL SIDE REAR	0690-0003-201
109	PANEL-REAR RIGHT	0690-0018-2
110	PANEL-REAR CENTER	0690-0018-3
111	COVER-ELECTRICAL SIDE FRONT	0690-0003-202
112	DOOR-FUSE	0690-0141

FOR SERVICE PARTS CALL OLIVER PRODUCTS @ 800-253-3893  
Revised 12/10/2012



### 690-NC2 DOOR ASSEMBLY

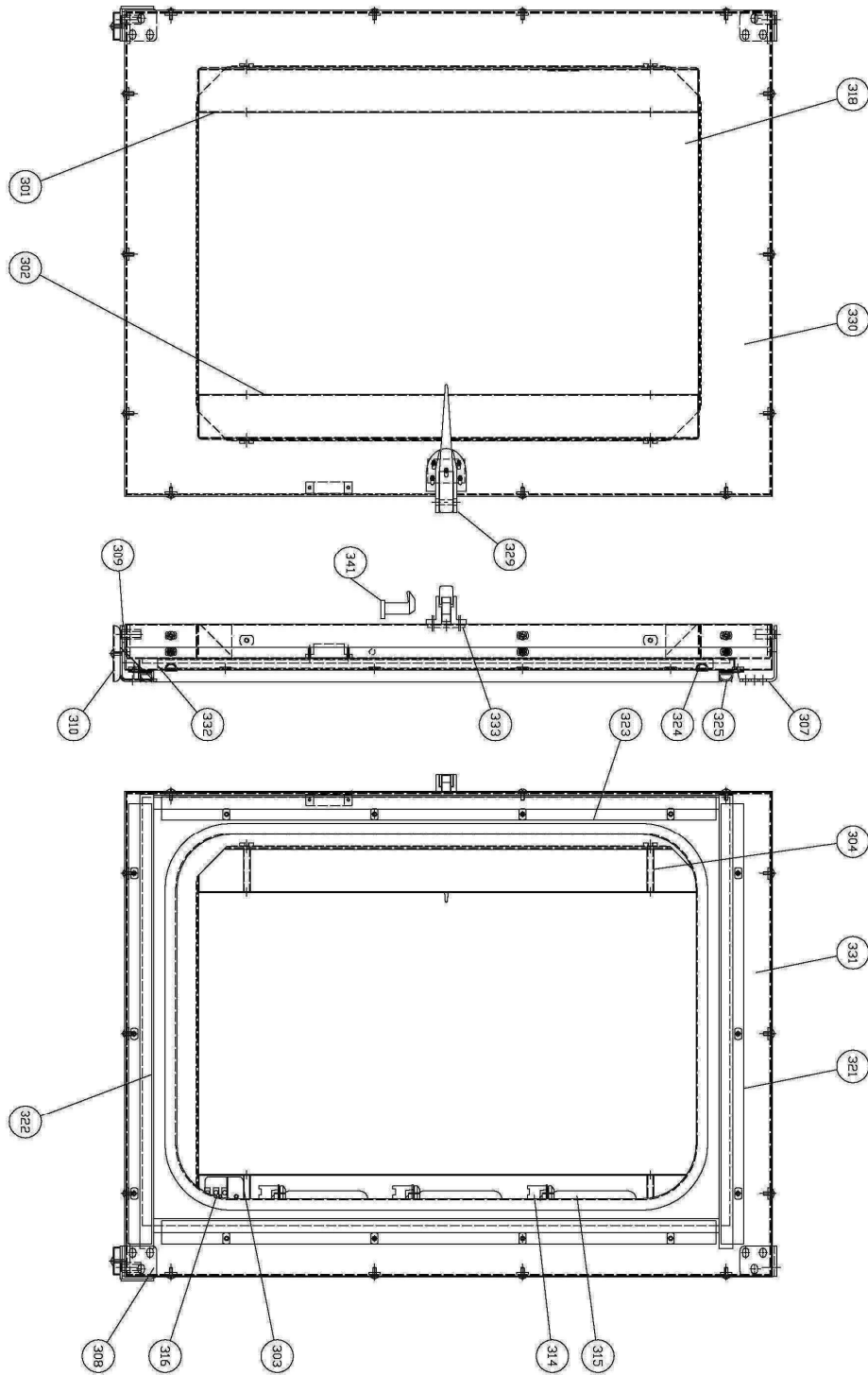

Rev. 12/10/2012



Oliver Packaging & Equipment Company  
3236 WISON DR NW WALKER MI. 49534

(800) 253-3893  
www.oliverquality.com

690-NC2

**DOOR ASSEMBLY PARTS LIST**

<b>ITEM NO</b>	<b>PART DESCRIPTION</b>	<b>PART NUMBER</b>
301	HOUSING-EMPTY	0690-0021
304	TUBE-SPACER	0690-0024
307	BRACKET-TOP DOOR HOLD	0690-0027
308	BRACKET-BOTTOM DOOR HOLD	0690-0028-1
309	SPACER-DOOR	0690-0030
310	COVER-WIRE	0690-0031
318	GLASS-DOOR	6542-0003
321	FRAME GASKET	0690-0152
324	GASKET-GLASS & DOOR	6904-6062
329	LATCH-BODY	5911-9030
330	DOOR-OUTSIDE	0690-0087-2
331	DOOR-OUTER BACK	0690-0088-3
332	DOOR-INSIDE ASSEMBLY	0690-0089-2
333	NUTBAR	0690-0110-2
334	LAMP-FLUORESCENT 36 WATT	5737-2010
335	SOCKET-LAMP	5737-2910
336	HOUSING-LAMP	0690-0022-1
337	RETAINER-LAMP CLIP	0690-0129
340	CLIP-HORIZONTAL LAMP	5737-2911
341	STRIKE-LATCH	0690-0149

FOR SERVICE PARTS CALL OLIVER PRODUCTS @ 800-253-3893

Rev. 12/10/2012



690-NC2  
**OUSIN C AMBER ASSEMBLY**

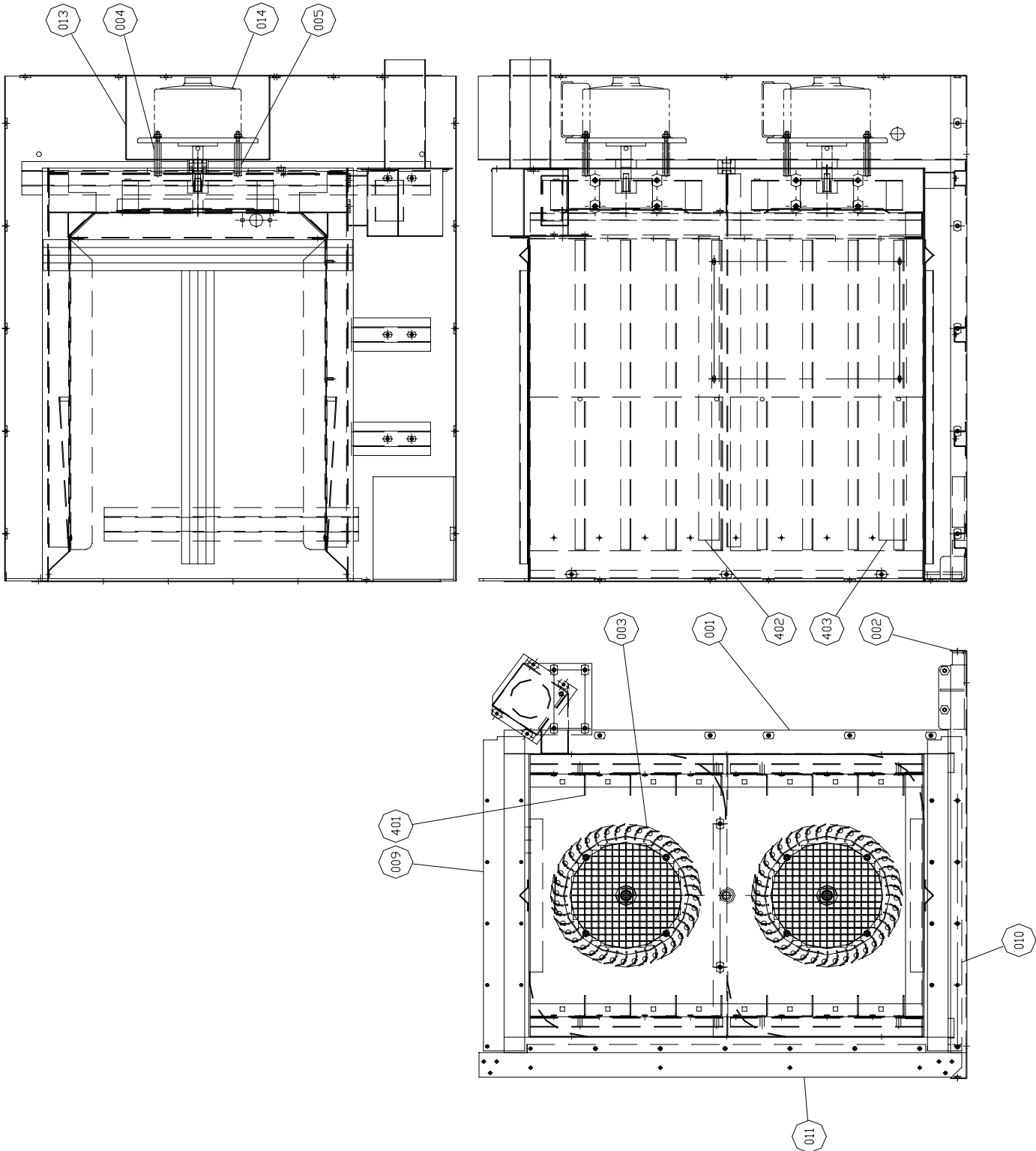



Oliver Packaging & Equipment Company  
3236 WISON DR NW WALKER MI. 49534

(800) 253-3893  
www.oliverquality.com

690-NC2

**OUSIN C AMBER PARTS LIST**

<b>ITEM NO</b>	<b>PART DESCRIPTION</b>	<b>PART NUMBER</b>
001	HOUSING-MAIN	0690-0029-2
002	BASE	0690-0037-1
003	WHEEL-BLOWER	0690-0045
004	SPACER-LONG MOTOR	0690-0058
005	SPACER-SHORT MOTOR	0690-0059
009	PLATE-UPPER SPLICE	0690-0063
010	PLATE-LOWER SPLICE	0690-0064
011	PLATE-SIDE SPLICE	0690-0065
013	PLATE-MOTOR BAFFLE	0690-0067-2
014	MOTOR-BLOWER 230/460/3	0690-0004
*015	HOUSING-PACKING ADJUSTABLE	0690-0158
401	INNER CHAMBER-8 SHELF	0690-0020
402	BAFFLE-UPPER	0690-0056
403	BAFFLE-LOWER	0690-0057

\*ITEMS NOT SHOWN  
FOR SERVICE PARTS CALL OLIVER PRODUCTS @ 800-253-3893  
Rev. 3/8/05



690-NC2  
**ATER SYSTEM ASSEMBLY**

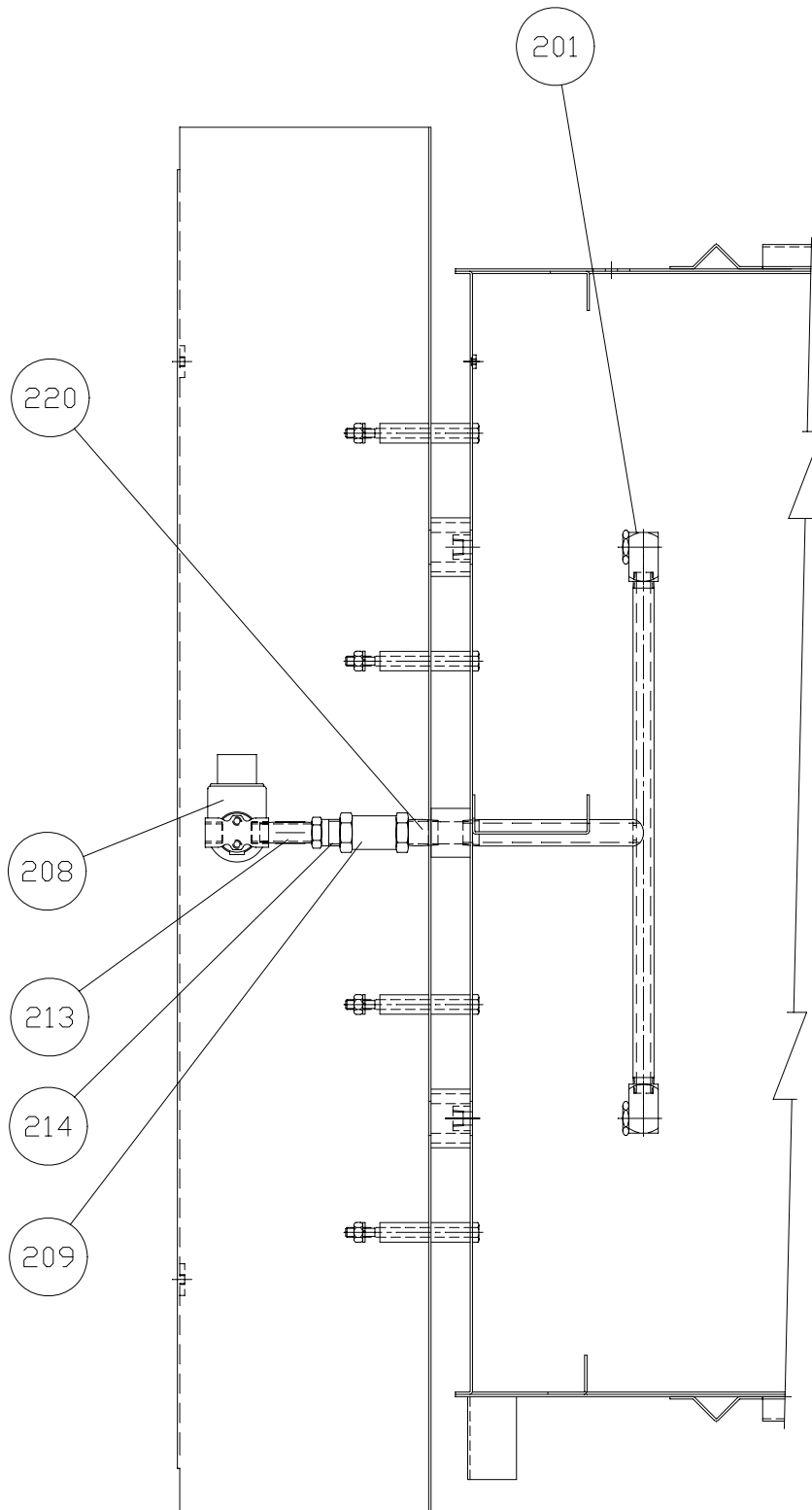



Oliver Packaging & Equipment Company  
3236 WISON DR NW WALKER MI. 49534

(800) 253-3893  
www.oliverquality.com

690-NC2

**ATER SYSTEM ASSEMBLY PARTS LIST**

<b><u>ITEM NO</u></b>	<b><u>PART DESCRIPTION</u></b>	<b><u>PART NUMBER</u></b>
201	MANIFOLD-ASSEMBLED	0690-0011
208	VALVE-SOLENOID 2WAY	5148-6718
209	VALVE-WATER FLOW CONTROL	5148-7408
213	NIPPLE-1/4 NPT X 1-1/2	5115-8250
214	BUSHING-REDUCER 3/8x1/4 NPT	5115-8300
220	NIPPLE-CLOSE 3/8" X 1"	5115-8251

FOR SERVICE PARTS CALL OLIVER PRODUCTS @ 800-253-3893



690-NC2  
**DAMPER CONTROL ASSEMBLY**

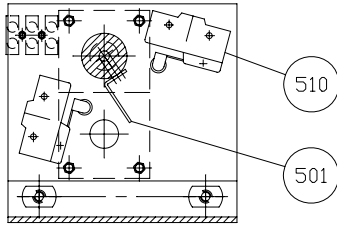

SECTION A-A

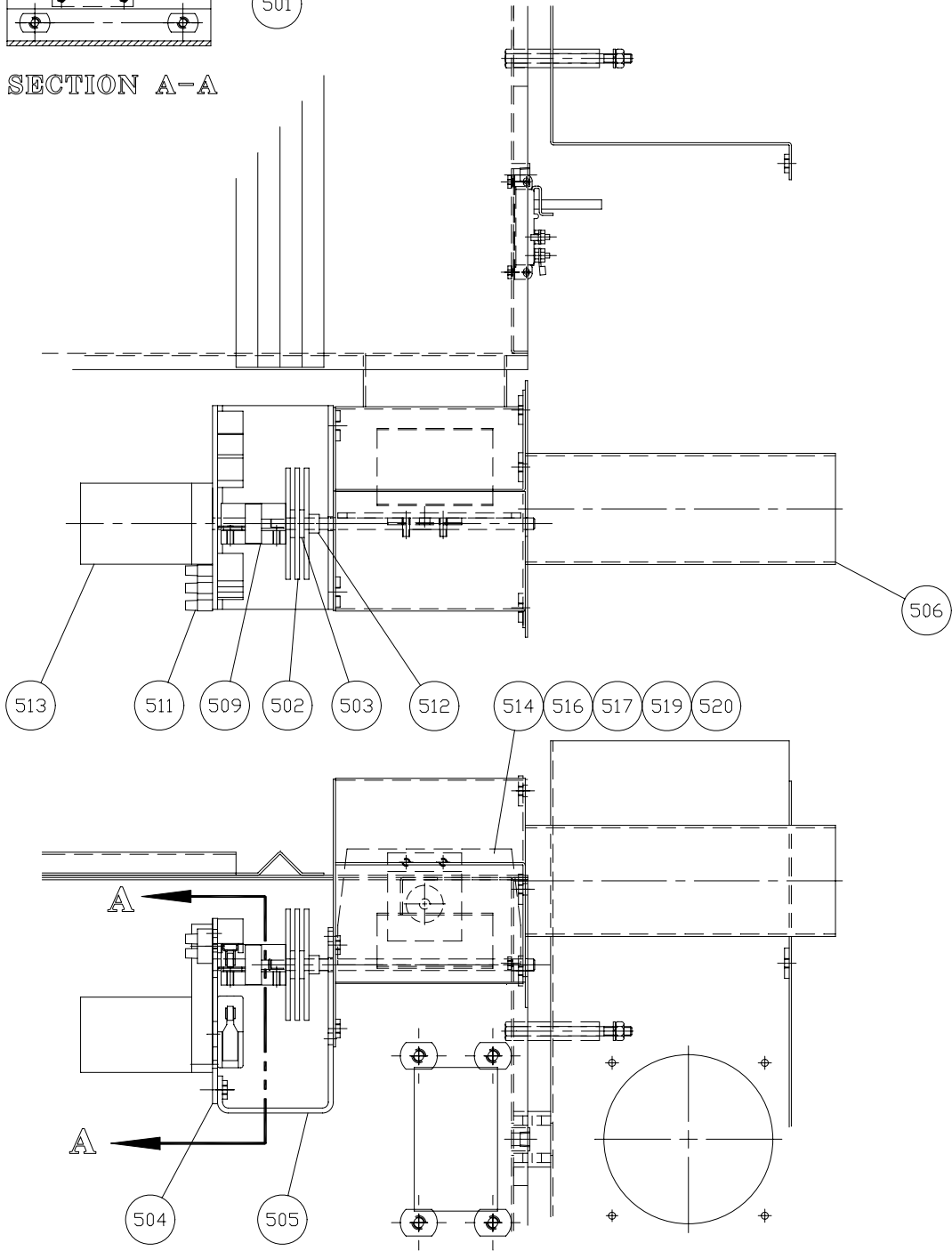



690-NC2

**DAMPER CONTROL ASSEMBLY PARTS LIST**

<b><u>ITEM NO</u></b>	<b><u>PART DESCRIPTION</u></b>	<b><u>PART NUMBER</u></b>
501	LEVER-LIMIT SWITCH	0690-0046
502	DISK-HEAT SINK	0690-0047
503	SPACER-HEAT SINK	0690-0048
504	PLATE-MOTOR	0690-0049
505	BRACKET-DAMPER MOTOR	0690-0050
506	CHIMNEY	0690-0051
509	COUPLING-5/16B	5604-6951
510	SWITCH-LIMIT (DAMPER)	5757-8083
511	BLOCK-TERMINAL	5770-7169
512	COLLAR-SET	5806-7053
513	MOTOR-GEAR	6310-0003
514	PLATE-DAMPER	0690-0055-1
516	BRACKET-FLAP (2 X 1/2)	0690-0101
517	FLAP-RUBBER PRES. RELIEF	0690-0102
519	SCREW-MACH #10 X 3/4	5843-5240
520	NUT-HEX MACHINE #10-24	5832-0578

FOR SERVICE PARTS CALL OLIVER PRODUCTS @ 800-253-3893



690-NC2

# IRIN DIA RAM D

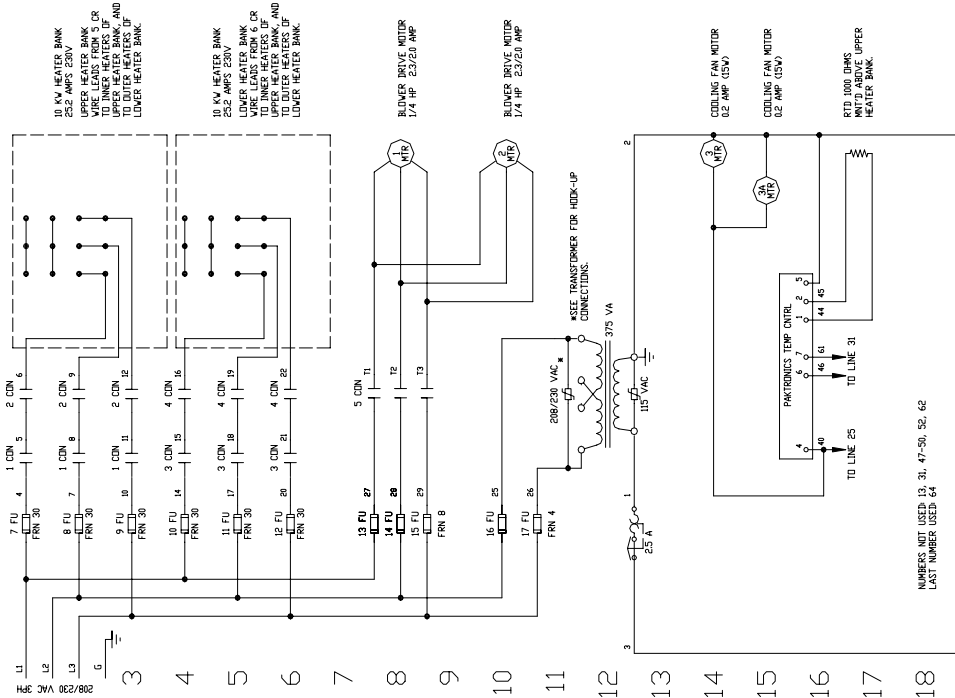
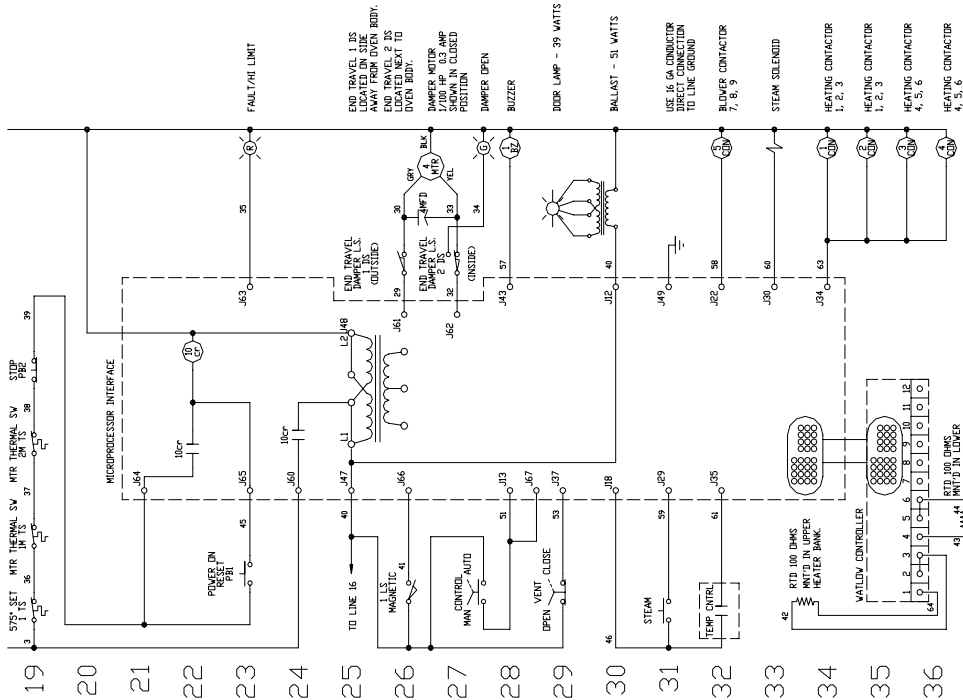

Revised 2-27-09





### 690-NC2 INTER ACE BOARD SC EMATICS

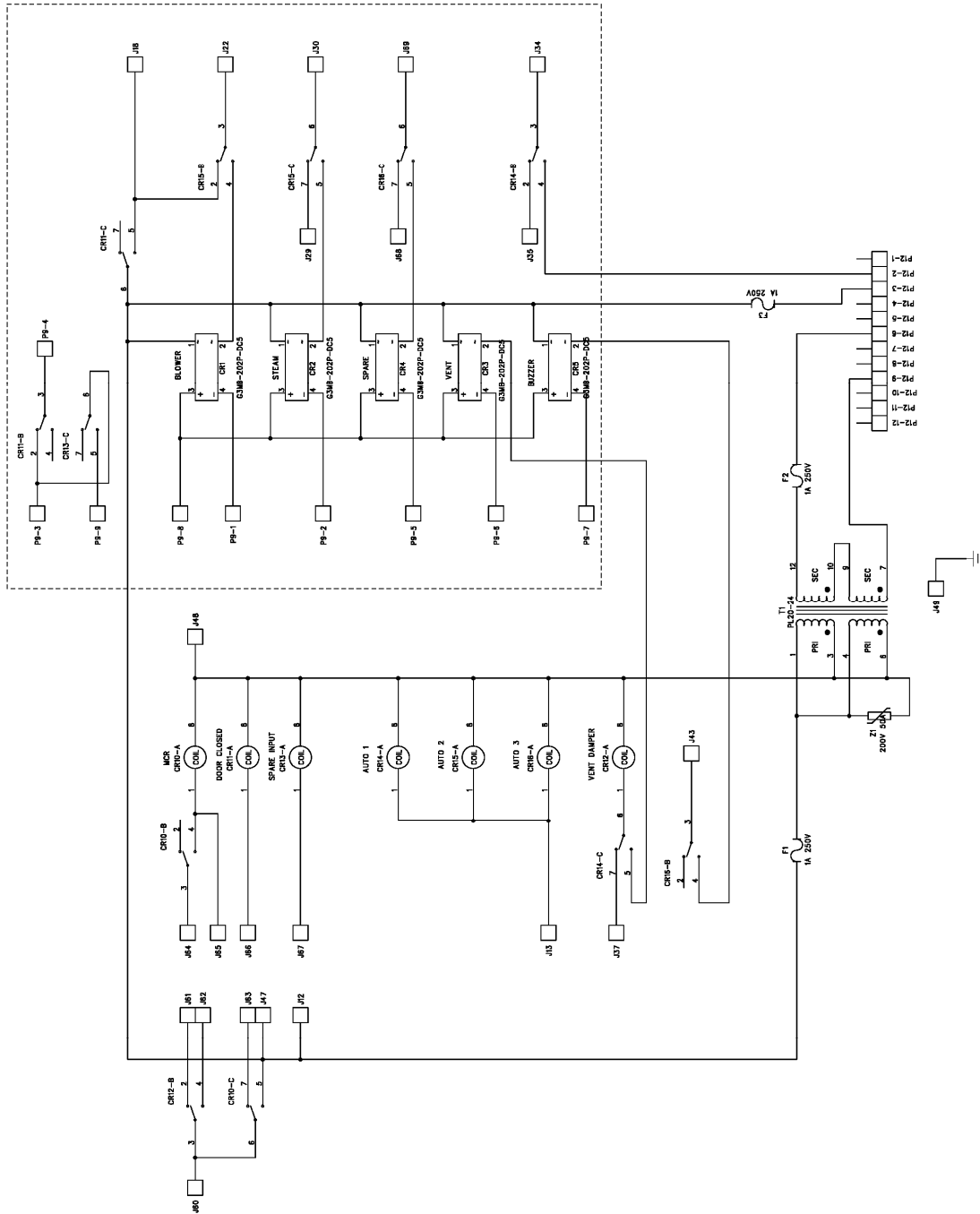



Oliver Packaging & Equipment Company  
3236 WISON DR NW WALKER MI. 49534

(800) 253-3893  
www.oliverquality.com

## ARRANTY

### PARTS

Oliver Packaging & Equipment Company warrants that if any part of the equipment (other than a part not manufactured by Oliver Packaging & Equipment ) proves to be defective (as defined below) within one year after shipment, and if Buyer returns the defective part to Oliver Packaging & Equipment within one year, Freight Prepaid to Oliver Packaging & Equipment plant in Grand Rapids, MI, then Oliver Packaging & Equipment , shall, at Oliver Packaging & Equipment option, either repair or replace the defective part, at Oliver Packaging & Equipment expense.

### LABOR

Oliver further warrants that equipment properly installed in accordance with our special instructions, which proves to be defective in material or workmanship under normal use within one (1) year from installation or one (1) year and three (3) months from actual shipment date, whichever date comes first, will be repaired by Oliver Packaging & Equipment or an Oliver Packaging & Equipment Authorized Service Dealer, in accordance with Oliver Packaging & Equipment published Service Schedule.

For purposes of this warranty, a defective part or defective equipment is a part or equipment which is found by Oliver Packaging & Equipment to have been defective in materials workmanship, if the defect materially impairs the value of the equipment to Buyer. Oliver Packaging & Equipment has no obligation as to parts or components not manufactured by Oliver Packaging & Equipment, but Oliver Packaging & Equipment assigns to Buyer any warranties made to Oliver Packaging & Equipment by the manufacturer thereof.

This warranty apply to:

1. Damage caused by shipping or accident.
2. Damage resulting from improper installation or alteration.
3. Equipment misused, abused, altered, not maintained on a regular basis, operated carelessly, or used in abnormal conditions.
4. Equipment used in conjunction with products of other manufacturers unless such use is approved by Oliver Packaging & Equipment Company in writing.
5. Periodic maintenance of equipment, including but not limited to lubrication, replacement of wear items, and other adjustments required due to installation, set up, or normal wear.
6. Losses or damage resulting from malfunction.

The foregoing warranty is in lieu of all other warranties expressed or implied AND OLIVER PACKAGING & EQUIPMENT COMPANY MAKES NO WARRANTY OF MERCHANTABILITY OR FITNESS FOR PURPOSE REGARDING THE EQUIPMENT COVERED BY THIS WARRANTY. Oliver Packaging & Equipment Company neither assumes nor authorizes any person to assume for it any other obligations or liability in connection with said equipment. OLIVER PACKAGING & EQUIPMENT COMPANY SHALL NOT BE LIABLE FOR LOSS OF TIME, INCONVENIENCE, COMMERCIAL LOSS, INCIDENTAL OR CONSEQUENTIAL DAMAGES.



Oliver Packaging & Equipment Company  
3236 WISON DR NW WALKER MI. 49534

(800) 253-3893  
[www.oliverquality.com](http://www.oliverquality.com)

## **ARRANTY PROCEDURE**

1. If a problem should occur, either the dealer or the end user must contact the Parts and Service Department and explain the problem.
2. The Parts and Service Manager will determine if the warranty will apply to this particular problem.
3. If the Parts and Service Manager approves, a Work Authorization Number will be generated, and the appropriate service agency will perform the service.
4. The service dealer will then complete an invoice and send it to the Parts and Service Department at Oliver Packaging & Equipment Company.
5. The Parts and Service Manager of Oliver Packaging and Equipment Company will review the invoice and returned parts, if applicable, and approve for payment.



Oliver Packaging & Equipment Company  
3236 WISON DR NW WALKER MI. 49534

(800) 253-3893  
[www.oliverquality.com](http://www.oliverquality.com)

## RETURNED PARTS POLICY

This policy applies to all parts returned to the factory whether for warranted credit, replacement, repair or re-stocking.

Oliver Packaging and Equipment Company requires that the customer obtain a Return Material Authorization (RMA) number before returning any part. This number should appear on the shipping label and inside the shipping carton as well. All parts are to be returned prepaid. Following this procedure will insure prompt handling of all returned parts.

To obtain an RMA number contact the Repair Parts Department toll free at (800) 253-3893.

Parts returned for re-stocking are subject to a **RE STOC IN C AR E**.

Thank you for your cooperation,

Repair Parts Manager  
Oliver Packaging and Equipment Company