



Walker, Michigan, U.S.A. 49534-7564

USER'S OPERATING AND INSTRUCTION MANUAL

MODEL 732-N

BREAD SLICER

732-N FRONT LOAD SLICER

INDEX

<u>Section Description</u>	<u>Document No.</u>	<u>Page No.</u>
SAFETY INSTRUCTIONS -----	0732S20002 -----	1-1
DESCRIPTION/SPECIFICATIONS -----	0732S20003 -----	2-1
Description -----		2-1
Specifications -----		2-1
INSTALLATION INSTRUCTIONS -----	0732S20004 -----	3-1
Slicer Installation -----		3-1
OPERATING INSTRUCTIONS -----	0732S20005 -----	4-1
TROUBLESHOOTING -----	0732S20006 -----	5-1
The Slicer Will Not Start (Motor is Not Humming) -----		5-1
The Slicer Will Not Start (Motor is Humming) -----		5-2
The Slicer Stops Before Slicing is Complete -----		5-2
The Slicer Does Not Automatically Stop Upon Completion of Slicing -----		5-2
Bread Slices Vary in Thickness -----		5-3
The Blade Frames are Knocking -----		5-3
The Slicer Vibrates Excessively -----		5-3
The Hand Lever Pulls Hard -----		5-3
The Bread is Cutting Slowly or is Being Damaged -----		5-4
MAINTENANCE -----	0732S20007 -----	6-1
Removing the Blade Frames -----		6-1
Replacing the Blade Frames -----		6-4
Changing the Blades -----		6-5
Tightening the Belt -----		6-7
Replacing the Belt -----		6-8
Replacing the Gas Spring -----		6-9
Adjusting the Gas Spring -----		6-12
Adjusting the Blade Frames When Slices Vary in Thickness -----		6-13
Adjusting the Clearance Between the Blade Frames -----		6-14
Lubrication -----		6-15
Cleaning -----		6-15
RECOMMENDED SPARE PARTS -----	0732S20008 -----	7-1
REPLACEMENT PARTS SECTION		
MAIN FRAME -----	0732S20009 -----	8-1
Drawing -----		8-1
Parts List -----		8-2

Continued

**732-N FRONT LOAD SLICER
INDEX (Continued)**

REPLACEMENT PARTS SECTION (Continued)

<u>Section Description</u>	<u>Document No.</u>	<u>Page No.</u>
COVERS -----	0732S20010 -----	9-1
Drawing -----		9-1
Parts List -----		9-2
PUSHER -----	0732S20011 -----	10-1
Drawing -----		10-1
Parts List -----		10-2
ROCKER -----	0732S20012 -----	11-1
Drawing -----		11-1
Parts List -----		11-2
DRIVEN PULLEY -----	0732S20013 -----	12-1
Drawing -----		12-1
Parts List -----		12-2
SLICE PARTS -----	0732S20014 -----	13-1
Drawing -----		13-1
Parts List -----		13-2
ELECTRICAL -----	0732S20015 -----	14-1
Drawing -----		14-1
Parts List -----		14-2
WIRING DIAGRAM 1-60-115/230 -----	0732S20016 -----	15-1
WARRANTY -----	GEN 040228	
WARRANTY PROCEDURE-----	GEN 040226	
RETURNED PARTS POLICY -----	GEN 040227	

**732-N FRONT END SLICER
SAFETY INSTRUCTIONS**

WARNING

VARIOUS SAFETY DEVICES AND METHODS OF GUARDING HAVE BEEN PROVIDED ON THIS MACHINE. IT IS ESSENTIAL HOWEVER THAT THE MACHINE OPERATORS AND MAINTENANCE PERSONNEL OBSERVE THE FOLLOWING SAFETY PRECAUTIONS. IMPROPER INSTALLATION, MAINTENANCE, OR OPERATION OF THIS EQUIPMENT COULD CAUSE SERIOUS INJURY OR DEATH.

1. Read this manual before attempting to operate your machine. Never allow an untrained person to operate or service this machine.
2. Connect the machine to a properly grounded electrical supply that matches the requirements shown on the electrical specification plate and follow all specifications of local electrical codes.
3. Disconnect and lock-out the machine from the power supply before cleaning or servicing.
4. Check and secure all guards before starting the machine.
5. Observe all caution and warning labels affixed to the machine.
6. Use only proper replacement parts.
7. Do not wear loose fitting clothing or loose hair when working near this machine. Shirt tails should be tucked in.
8. Wear proper, personal, protective, safety equipment.
9. Keep Hands away from the moving parts of this machine while it is in operation.
10. In addition to these general safety instructions, please follow the more specific safety instructions in the rest of this operating instruction manual.

WARNING

DO NOT USE FOR OTHER THAN ORIGINALLY INTENDED PURPOSE.

732-N FRONT END SLICER

DESCRIPTION/SPECIFICATIONS

Description

The Oliver Model 732-N Counter Top Bread Slicer is of a compact, sturdy, time tested design, which has been used in bakeries worldwide for many years. The machine is easy to operate and can be loaded and unloaded from the front of the machine. It is capable of slicing either hard crusted breads or soft-textured sandwich loaves with ease and precision. After slicing, the bread can be easily packaged with the use of its convenient front mounted bagging scoop. Its design will provide years of efficient, trouble-free operation requiring a minimum of maintenance.

The Model 732-N Bread Slicer is of stainless, plated, and painted steel construction for easy cleaning and maintenance. As with other Oliver slicers it is so easy to change the blades, when that becomes necessary, that most operators will feel comfortable enough to do it themselves eliminating the need of a service call.

Oliver Products Company, who has a reputation of serving the Baking Industry for over 70 years, backs these slicers.

Specifications

Space Requirements:

Model 732-N (All Dimensions are Approximate, Shown with 4" NSF legs installed)

NOTE

**CUSTOMER TO INSTALL 4" LEG EXTENSIONS TO MEET NSF REQUIREMENT
(4" legs used for countertop Installation only)**

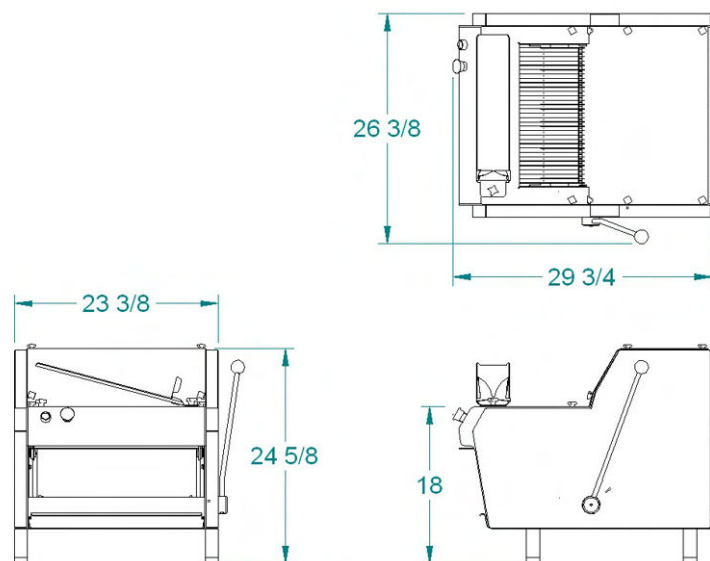

732-N FRONT END SLICER

Product Capacities:

Length	16 Inches
Width	5-1/2 inches (See Note)
Height	5-1/2 inches (See Note)

NOTE

WIDTH AND HEIGHT DIMENSIONS ARE FOR A SQUARE PRODUCT. LOWER AND WIDER PRODUCTS MAY ALSO BE SLICED BY TAKING CARE IN LOADING THE PRODUCT. INDIVIDUAL DETERMINATIONS WOULD HAVE TO BE MADE.

Standard Electrical Options: (Others consult factory).

- 1 phase, 60 hz, 115VAC, 7 Amps.
- 1 phase, 60 hz, 230VAC, 3.5 Amps.
- 1 phase, 50 hz, 220VAC, 3.5 Amps.

Standard Slice Spacings,

3/8, 7/16, 1/2 and 5/8 (inches)

Shipping Weight

300 lbs. (approximate)

Net Weight

250 lbs. (approximate)

732-N FRONT END SLICER INSTALLATION INSTRUCTIONS

Slicer Installation:

Before starting the Installation process make sure you observe the following three caution notes.

CAUTION

**THE SLICER IS HEAVY, USE PROPER TECHNIQUE WHEN LIFTING.
KEEP BACK STRAIGHT, KNEES BENT, AND LIFT WITH LEGS.
USE GLOVES TO PROTECT HANDS.**

CAUTION

NEVER LIFT THE SLICER BY ITS SIDE COVERS.

CAUTION

**BEFORE PLACING THE SLICER ON THE TABLE OR COUNTER MAKE SURE THAT
IT CAN SUPPORT THE SLICER'S WEIGHT WHICH IS APPROX. 250 POUNDS.**

Select a location for your slicer which has a substantial mounting surface, (see the caution note above), and which has electrical service compatible with the load the machine will place on it as indicated on the electrical data plate of the machine.

Position the machine while it is still in its packaging as close as possible to the desired end location. Expose the machine by removing the outer packaging and remove its crumb tray. Using at least two people, (one in the front and one at the back of the machine), lift the slicer from the resting surface of the packaging and set the machine onto the counter or table as close as possible to the desired end location. Make final location adjustments by sliding the machine to its desired location.



732 FRONT END SLICER

OPERATING INSTRUCTIONS

WARNING

ALWAYS USE CARE WHENEVER WORKING NEAR THE CUTTING KNIVES.

To operate the slicer, stand in front of the machine and grasp the lever with your right hand. Pull the lever all the way down and hold it in position. Using your left hand load the product into the machine.

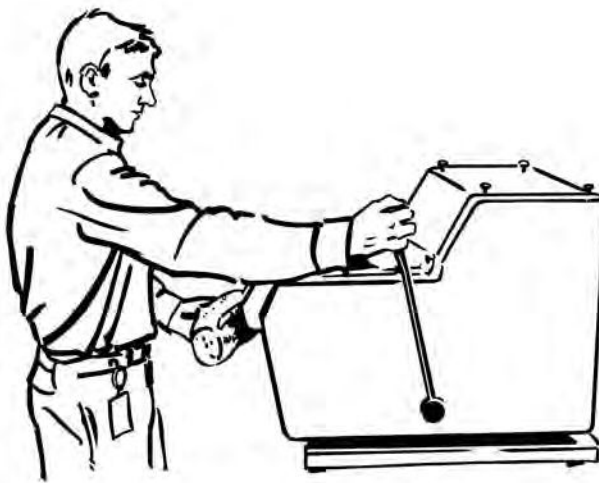

WARNING

NEVER START MACHINE BEFORE LOADING THE PRODUCT.

Make sure that the product does not hang over either edge of the cradle. While holding the lever completely forward, (the machine will not start unless this is done), push the Green “Start” button with your left hand.

After starting the machine restrain the hand lever slightly allowing it to return slowly until the knives have contacted the **AND** penetrated the crust on the product. At this point allow the lever to return at it’s own speed.

CAUTION

NEVER PUSH THE HAND LEVER.

732 FRONT END SLICER

Operating Instructions (Continued)

When the slicing operation is complete the machine will automatically stop. Once stopped, remove the product from the cradle. Use of the standard front mounted bagging scoop will ease packaging of your product.



The bagging scoop's bread stop is adjustable to accommodate various size loaves. To adjust, apply pressure to the outside edges of the bread stop and slide along the scoop to the desired position.

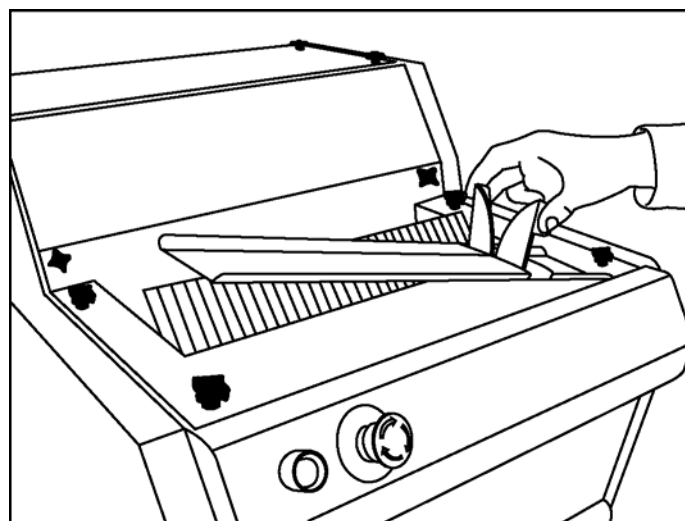

732-N FRONT END SLICER TROUBLE SHOOTING

WARNING

ALWAYS DISCONNECT THE SLICER FROM THE POWER SUPPLY BEFORE ATTEMPTING ANY TYPE OF MAINTENANCE TASK, INCLUDING TROUBLESHOOTING.

The Slicer Will Not Start (Motor Is Not Humming)

- The machine is not plugged in.
- There is no power at the outlet. (Check by plugging in a small working appliance, like a lamp. Check to see if a circuit breaker has tripped. If the circuit breaker has not tripped and the circuit is still not working have a qualified electrician check the circuit.)
- The Emergency “Stop” button has been pushed. Twist the Red button in the direction of the arrow on the button to release it to its run position.
- The lever is not being **HELD** in the forward most position.
- There are bread crumbs beneath the cradle bracket or in the cradle guide tracks at each side of the cradle bracket preventing it from going all the way down, which it must do before the lower limit switch can be tripped.
- The lower limit switch is not adjusted properly. (Have a qualified service agent adjust the switch.)
- The lower limit switch is defective. (Have a qualified electrician check and replace the switch if required.)
- The problem is somewhere else in the electrical system of the machine. (Have a qualified electrician find and repair the problem.)

Continued

732-N FRONT END SLICER

Trouble Shooting (Continued)

The Slicer Will Not Start (Motor Is Humming)

CAUTION

**DO NOT ALLOW THE MOTOR TO HUM WITHOUT STARTING.
OVERHEATING CAN PERMANENTLY DAMAGE THE MOTOR.**

NOTE

A SPECIAL NON-VENTILATED MOTOR MUST BE USED WITH THIS SLICER.

- The drive system is binding. (Have a qualified service agent check for defective bearings or other restrictions to free movement.)
- There is mechanical interference between other parts of the slicer. (Have a qualified service agent evaluate the machine for adjustment or replacement of defective parts.)
- The motor has failed. (Have it checked by a qualified electrician.)

The Slicer Stops Before Slicing is Complete

- The upper limit switch is not adjusted properly. (Have a qualified service agent adjust the switch.)

The Slicer Does Not Automatically Stop Upon Completion of Slicing

- The upper limit switch is not adjusted properly. (Have a qualified service agent adjust the switch.)
- The upper limit switch is defective. (Have a qualified electrician check and replace the switch if required.)
- A bread crust or other foreign object is preventing the cradle from returning to the top of its travel.

Continued

732-N FRONT END SLICER

Trouble Shooting (Continued)

Bread Slices Vary in Thickness

- The blade frames are out of adjustment. (See the “Maintenance” section of this manual under “Adjusting the Blade Frames When Slices Vary in Thickness” on how to correct this problem.)

The Blade Frames Are Knocking

- The blade frames are out of adjustment. (See the “Maintenance” section of this manual under “Adjusting the Clearance Between the Blade Frames” on how to perform this adjustment.)

The Slicer Vibrates Excessively

- The drive belt is loose or worn. (See the “Maintenance” section of this manual under “Tightening the Belt” or “Replacing the Belt” on how to make these corrections.)
- One or more of the bearings on the machine are failing. (Have a qualified service agent check for defective bearings and replace them as required.)
- The pins, (two eccentrics and two regular), and links at the top of the blade frames are worn. We suggest that these be replaced together. Mixing worn parts with new will shorten the life of the replacement parts. Remember, after replacing the pins and links the clearance between the blade frames must be re-adjusted. (See the “Maintenance” section of this manual under “Adjusting the Clearance Between the Blade Frames” on how to perform this adjustment.)

The Hand Lever Pulls Hard

- Check the Cradle guide tracks at each end of the cradle bracket for a build-up of foreign material.

Continued

732-N FRONT END SLICER

Trouble Shooting (Continued)

The Bread is Cutting Slowly or is Being Damaged

- The product you are attempting to slice is below the minimum height capacity of the machine.
- You are pushing the lever of the machine in an attempt to speed slicing. This may not only damage the product but may also damage the machine.
- If only certain products are cutting slowly the cutting speed you are experiencing may be normal for that particular product.
- The knives of the machine have become worn, (dull). (See the “Maintenance” section of this manual under “Changing the Cutting Knives”). Most owners can perform this item of maintenance without calling a service company.
- The blades are not aligned properly. (See the “Maintenance” section of this manual under “Adjusting the Clearance Between the Blade Frames” on how to perform this adjustment.)
- The Gas spring may require adjustment or replacement. (See the Maintenance section of this manual under “Gas Spring Replacement” on how to perform this task.)

732-N FRONT END SLICER MAINTENANCE

Removing the Blade Frames

WARNING

ALWAYS UNPLUG THE SLICER BEFORE PERFORMING ANY TYPE OF MAINTENANCE TASK.

Remove the bagging scoop, the top and front covers by removing the ten knobs which secure them. Only remove the infeed table in the event that you **MUST** remove the lower blade frame. See the note below.

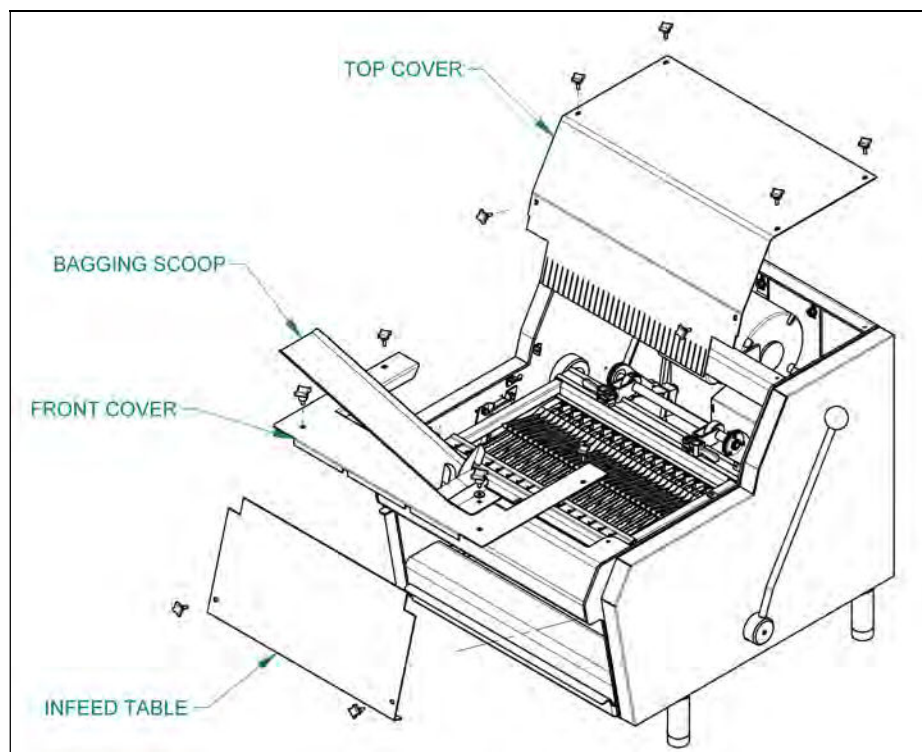

NOTE

REMOVAL OF THE LOWER BLADE FRAME IS NOT REQUIRED TO CHANGE ITS BLADES

Should it be necessary to remove the lower blade frame you must first remove the infeed table by removing the two knobs which secure it in place and then by pulling the table down out of the clips and out through the infeed opening. See above illustration.

Continued

732-N FRONT END SLICER

Removing the Blade Frames (Continued)

NOTE

DO NOT LOOSEN THE NUTS WHICH SECURE THE ECCENTRIC PINS.

Pull the clip from the eccentric pin and slide the link toward the eccentric pin mounting plate. See the illustration below.

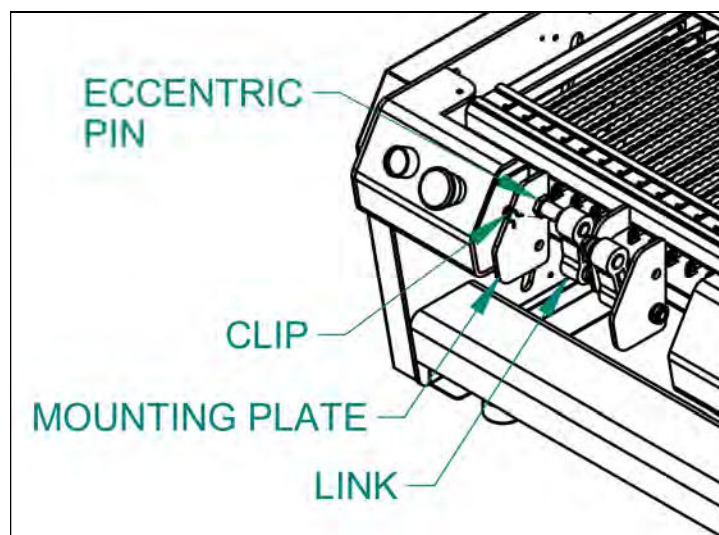

After removing the pair of locking cams, eyebolts and Belleville washers, (which secure each blade frame to the rocker's swing shaft), the blade frame can be lifted from the machine. The eyebolts and Belleville washers can be removed by turning them counter clockwise once the cams have been removed.

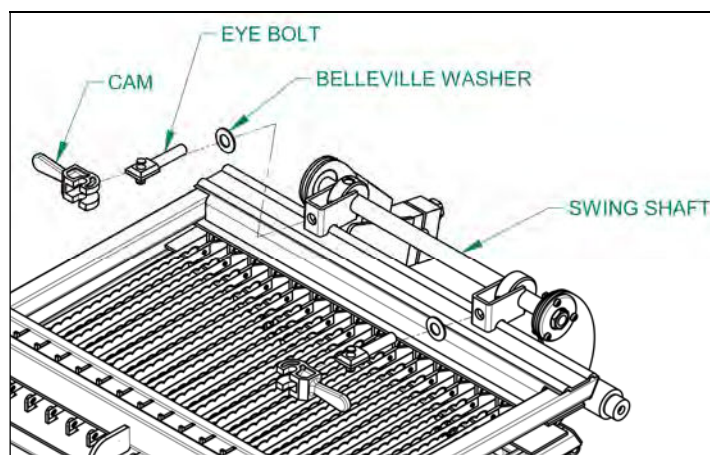

Continued

732-N FRONT END SLICER

Removing the Blade Frames (Continued)

WARNING

**BLADES ARE EXTREMELY SHARP ALWAYS HANDLE
BLADE FRAMES WITH CARE.**

Carefully lift the upper blade frame from the slicer.

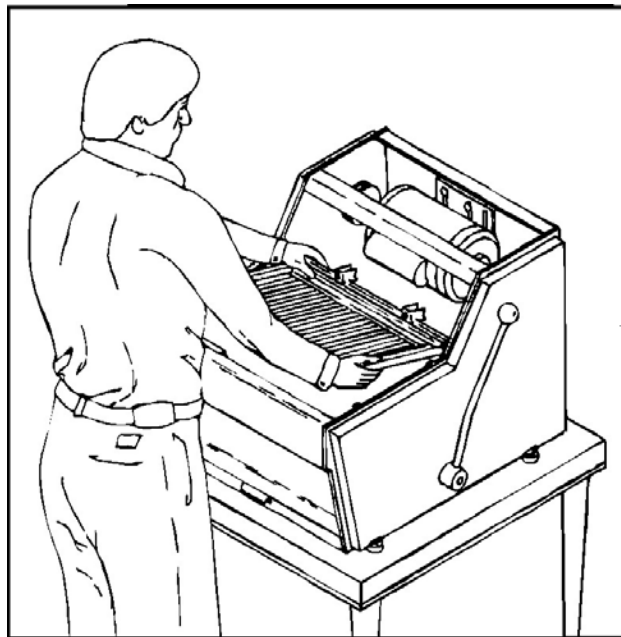

NOTE

**REMOVAL OF THE LOWER BLADE FRAME IS NOT REQUIRED
TO CHANGE ITS BLADES**

If you must remove the lower blade frame, remove the infeed table as described above, then with the cradle in its normal position remove the two cams, eyebolts, Belleville washers, clip and link from the lower blade frame just as it was done above for the upper blade frame.

732-N FRONT END SLICER

Replacing the Blade Frames

WARNING

ALWAYS DISCONNECT THE SLICER FROM THE POWER SUPPLY BEFORE ATTEMPTING ANY TYPE OF MAINTENANCE TASK.

Replacement of the blade frames is done by reversing the removal procedures. Ensure that the feet of the blade frames rest snugly on the swing shafts and that you have included the Belleville washers with the eye bolts.

NOTE

WHEN INSTALLING THE BELLEVILLE WASHERS, THEY MUST BE PLACED SO THAT THE CROWN IS UP AS SHOWN IN THE ILLUSTRATION BELOW.

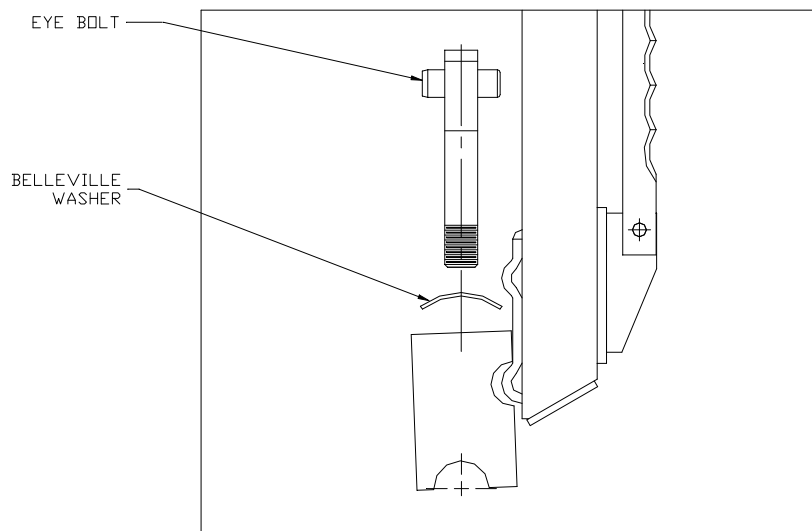

When replacing the eye bolts turn them clockwise until moderate pressure is required to close the cam. If the cam is too easy to close rotate the eye bolt a half turn more in the clockwise direction and try to reinstall the cam. Repeat these partial rotations until moderate pressure is required to close the cam. If the cams are either difficult or impossible to close, rotate the eye bolt a half turn in the counter clockwise direction. Repeating until the cams can be closed using moderate pressure.

732-N FRONT END SLICER

Changing the Blades

WARNING

ALWAYS DISCONNECT THE SLICER FROM THE POWER SUPPLY BEFORE ATTEMPTING ANY TYPE OF MAINTENANCE TASK.

WARNING

BLADES ARE EXTREMELY SHARP ALWAYS HANDLE WITH CARE.

NOTE

WHEN REPLACING ALL THE BLADES, ALWAYS REMOVE AND REPLACE ONE BLADE AT A TIME. NEVER REMOVE ALL THE BLADES AT ONCE AND THEN ATTEMPT TO REPLACE THEM ALL AT ONCE.

CAUTION

NEVER PUT BLADE FRAMES IN THE SLICER WITHOUT KNIVES.

First remove the upper blade frame from the machine, see “Removing the Blade Frames” above. You may use the special knife tools, shown in the illustrations on the next pages, or use a common set of pliers to decrease the tension on the blade. By lifting up on the tool as shown below, tension will be reduced on the blade so that it can be carefully removed. Remember you do not need to remove the lower blade frame to replace its blades.

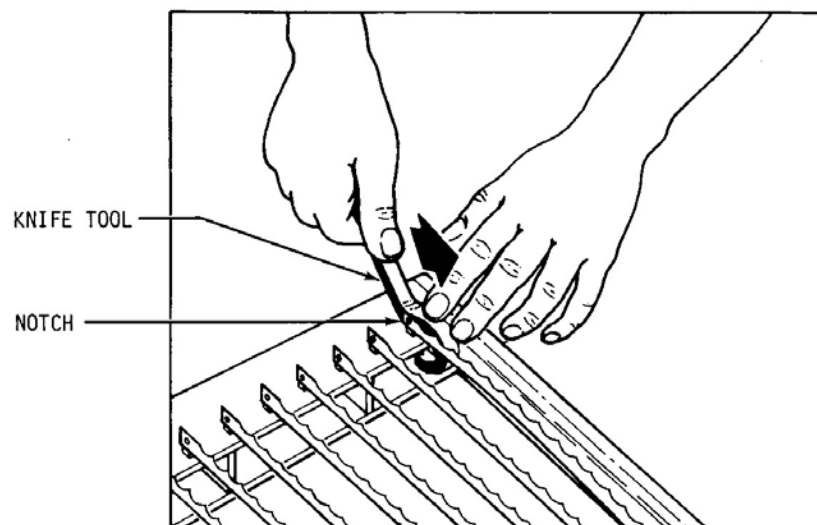

732-N FRONT END SLICER

Changing the Blades (Continued)

The new knife can be installed in the upper blade frame by reversing the removal procedure. A paper clip can be used to hold the knife in position on the lower pin to ease installation. See the illustration below. Remember to make sure that the sharp edge of the blade is pointing in the same direction as the edge on the blade which was just removed. Also remember to remove and replace one blade at a time.

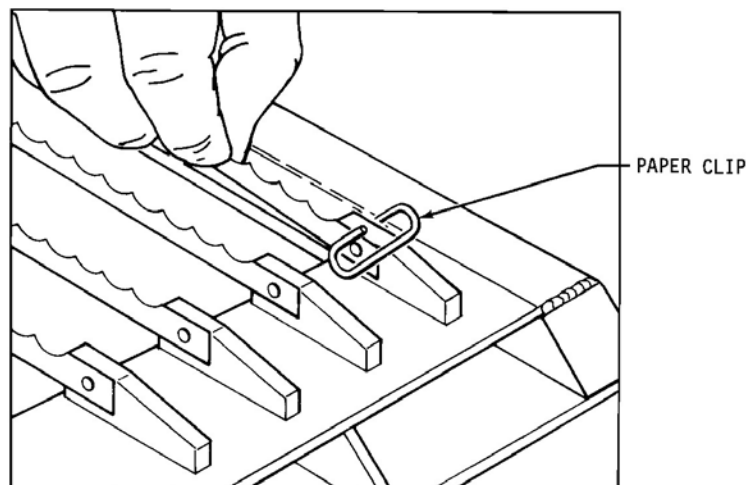

The blades can be removed from the lower blade frame while it is still in the machine. This is done by using a second special blade changing tool. Insert the tool into the blade frame, push the handle toward the feet of the blade frame as shown below. This will reduce the tension on the blade so that it can be carefully removed.

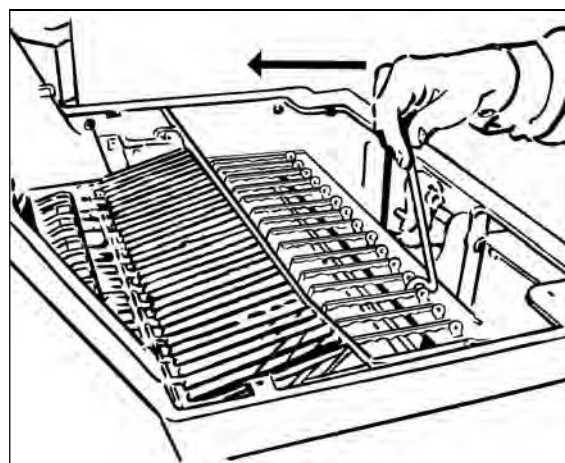

Using the same technique as used on the upper blade frame, replace the knives in the lower blade frame.

732-N FRONT END SLICER

Tightening the Belt

WARNING

ALWAYS DISCONNECT THE SLICER FROM THE POWER SUPPLY BEFORE ATTEMPTING ANY TYPE OF MAINTENANCE TASK.

CAUTION

OVER-TIGHTENING THE DRIVE BELT MAY CAUSE BEARING OR MOTOR FAILURE.

Remove the top cover by removing the six knobs which secure it. Then using a wrench loosen, but do not remove, the four nuts which secure the motor mounting plate to the machine.

CAUTION

DO NOT REMOVE THE MOTOR PLATE NUTS COMPLETELY.

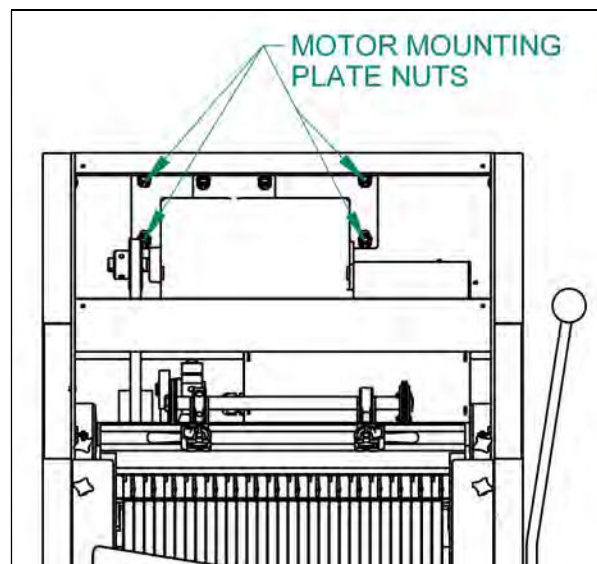

Manually lift the motor upward to tighten the belt using care to keep the centerline of the motor perpendicular to the centerline of the belt. The belt can be loosened by carefully moving the motor downward. The drive belt should be just tight enough, using moderate finger pressure, to allow a 3/8 inch deflection halfway between the motor drive pulley and the driven pulley. When desired belt tension is achieved, retighten the motor mounting nuts securely and replace the top cover.

732-N FRONT END SLICER

Replacing the Belt

WARNING

ALWAYS DISCONNECT THE SLICER FROM THE POWER SUPPLY BEFORE ATTEMPTING ANY TYPE OF MAINTENANCE TASK.

Remove the top cover by removing the six knobs which secure it. Using a wrench, loosen but do not remove the four nuts which secure the motor mounting plate to the machine. Move the motor and its mounting plate downward as far as it will go allowing the belt to loosen as much as possible. (See “Tightening the Belt” section).

CAUTION

DO NOT REMOVE THE MOTOR PLATE NUTS COMPLETELY.

Disconnect the end of the connecting rod attached to the rocker by removing the two hex cap screws and rod cap which secure the connecting rod to the rocker. Once this has been done you should be able to remove the belt.

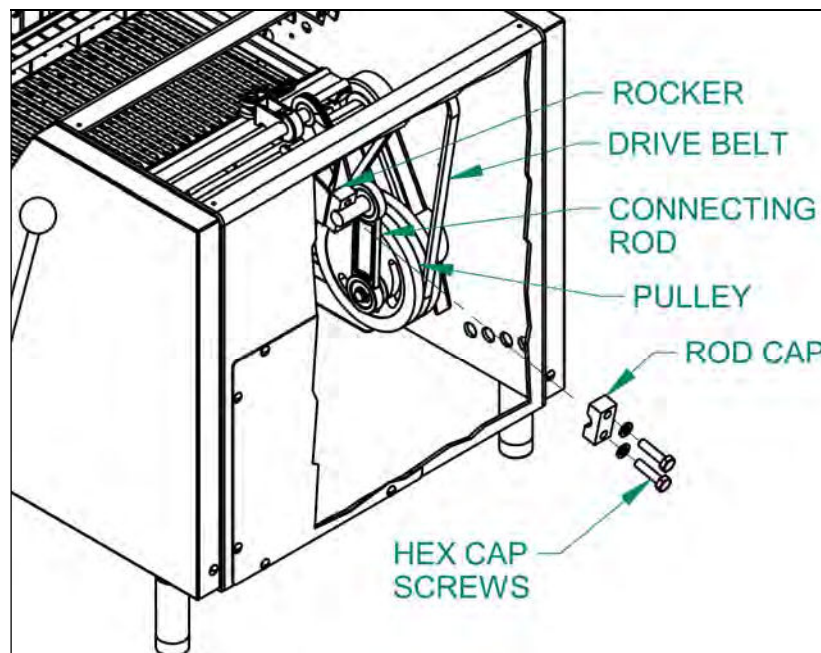

After replacing the belt reattach the connecting rod making sure to place the connecting rod as perpendicular as possible to the rocker's main shaft. Retighten the rod cap's bolts securely. Tighten the belt as described in the “Tightening the Belt” section of this manual and then replace the top cover.

732-N FRONT END SLICER

Replacing the Gas Spring

WARNING

ALWAYS DISCONNECT THE SLICER FROM THE POWER SUPPLY BEFORE ATTEMPTING ANY TYPE OF MAINTENANCE TASK.

The Gas Spring is located on the right hand side of the machine, therefore the right hand cover must be removed. Do this by first removing the hand lever by removing its set screw located in the hub. See the illustration below.

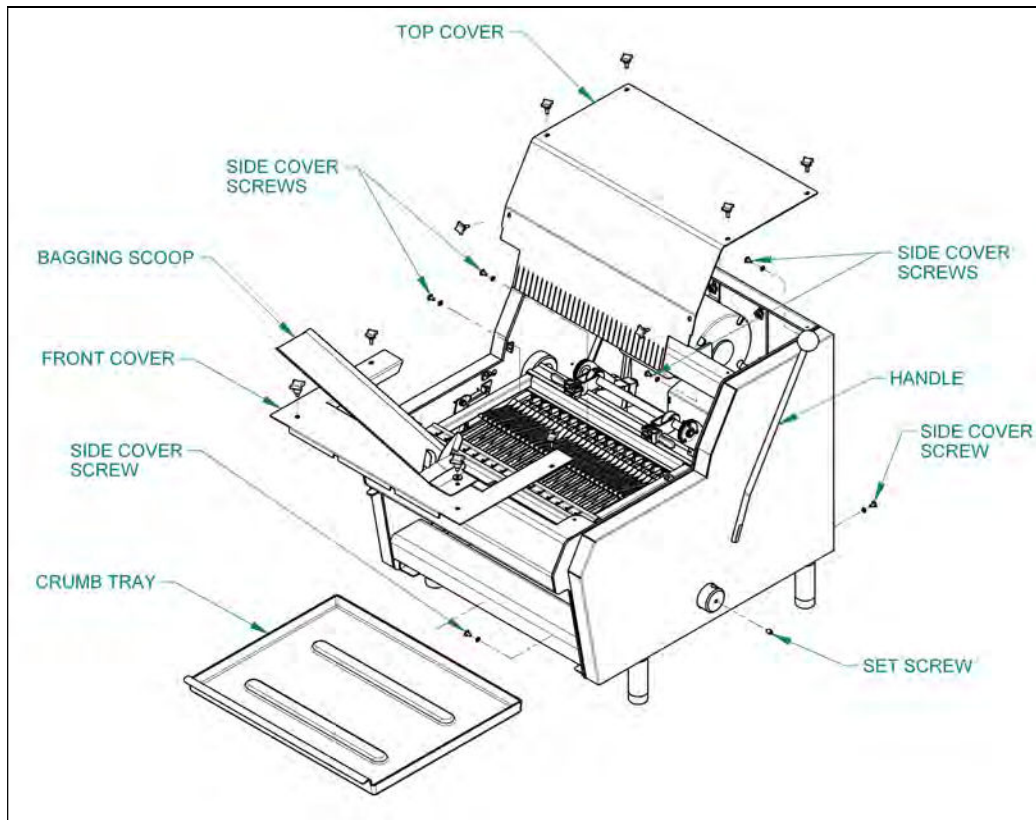

Remove the bagging scoop, the top and front guards by removing the ten knobs which secure them in place, also remove the crumb tray. Remove the handle by loosening the set screw which holds the handle after which it can be slid out of the hub. The cover can then be removed by first removing the six slotted head screws which secure it in place. See the above illustration to see their approximate locations.

Continued

732-N FRONT END SLICER

Replacing the Gas Spring (Continued)

WARNING

THE GAS SPRING IS IN A COMPRESSED STATE, USE CARE WHEN REMOVING IT FROM THE MACHINE.

To remove the gas spring, remove the push-on clip at the top of the gas spring by prying it off with a screw driver.

NOTE

THE CLIP IS NOT REUSABLE; A NEW ONE WILL BE REQUIRED.

After the clip is removed, the gas spring can then be pried off with a screwdriver, use care noting the above warning. See the next illustration for additional information. After the spring is off the pin the shoulder screw securing the lower end of the spring can be removed freeing the spring.

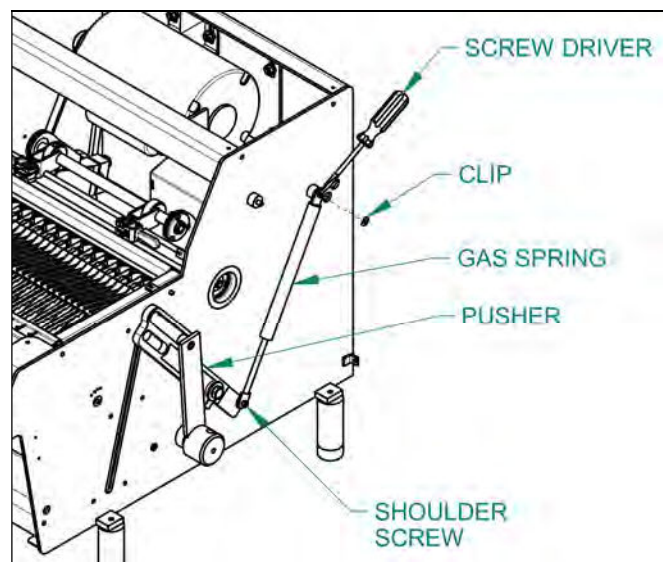

Install a gas spring by first attaching the lower end of the spring to the pusher arm with the shoulder screw.

CAUTION

USE A LOCKING FLUID, SUCH AS LOC-TITE[®], TO PREVENT THE SCREW FROM LOOSENING BECAUSE OF VIBRATION.

Continued

732-N FRONT END SLICER

Replacing the Gas Spring (Continued)

Using two people, grasp the spring as shown in the next illustration and slide the gas spring over the same upper pin that the old gas spring was removed from. See the caution statement below. After this is complete install the new clip and replace all of the covers. Lastly reinstall the hand lever.

CAUTION

**CARE MUST BE USED WHEN WORKING WITH THE GAS SPRING.
ALWAYS PUSH STRAIGHT DOWN OR SPRING DAMAGE MAY OCCUR.**

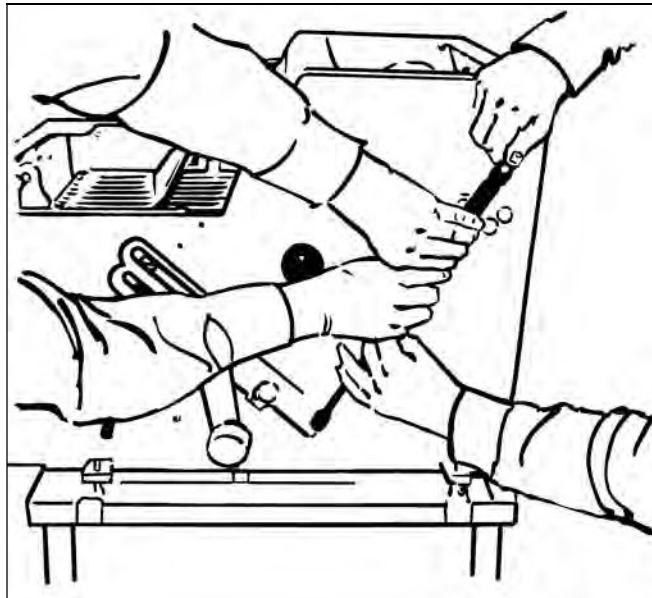

732-N FRONT END SLICER

Adjusting the Gas Spring

WARNING

ALWAYS DISCONNECT THE SLICER FROM THE POWER SUPPLY BEFORE ATTEMPTING ANY TYPE OF MAINTENANCE TASK.

CAUTION

FREQUENT ADJUSTMENT OF THE GAS SPRING IS NOT RECOMMENDED.

The gas spring must be removed and relocated to adjust its force. To remove the gas spring, see “Replacing the Gas Spring” above. There are two gas spring pins welded to the frame. The pin furthest from the front of the machine, (the standard position), should be used whenever possible. The standard position gives a gentle force at the beginning of the slicing operation, (when it is most needed), which will allow the knives to start cutting and prevent damage to the product. It also provides the most force at the end of the stroke to allow the cradle to finish its upward travel and the machine to shut off.

The pin located in the high forward position should be used when greater force is desired as the product is first entering the knives.

NOTE

NORMALLY DIFFICULT CUTTING BREADS REQUIRE LESS FORCE AT THE BEGINNING OF SLICING RATHER THAN MORE.

Using proper gas spring installation procedures, see “Replacing the Gas Spring” above, compress the spring and mount it on the desired pin. Secure it with a new clip.

732-N FRONT END SLICER

Adjusting the Blade Frames When Slices Vary In Thickness

WARNING

ALWAYS DISCONNECT THE SLICER FROM THE POWER SUPPLY BEFORE ATTEMPTING ANY TYPE OF MAINTENANCE TASK.

Assuming that the lower blade frame has been installed and centered in the machine, meaning that it has been aligned with the slots in the top cover and holddown, and secured with the locking cams, proceed as follows to adjust the upper blade frame. If the lower blade frame has not been centered the same process to be described for adjusting the upper blade frame should be used to center and secure the lower blade frame before you proceed.

To adjust the upper blade frame loosen both locking cams, and also loosen the set screw securing the "Locking Collar". Once this is done take a small hammer or mallet and tap the blade frame either to the right or left to equalize the distances between the blades. Once this is done secure the locking collar with the set screw and retighten the locking cams. After the covers have been replaced the machine should be ready to use.

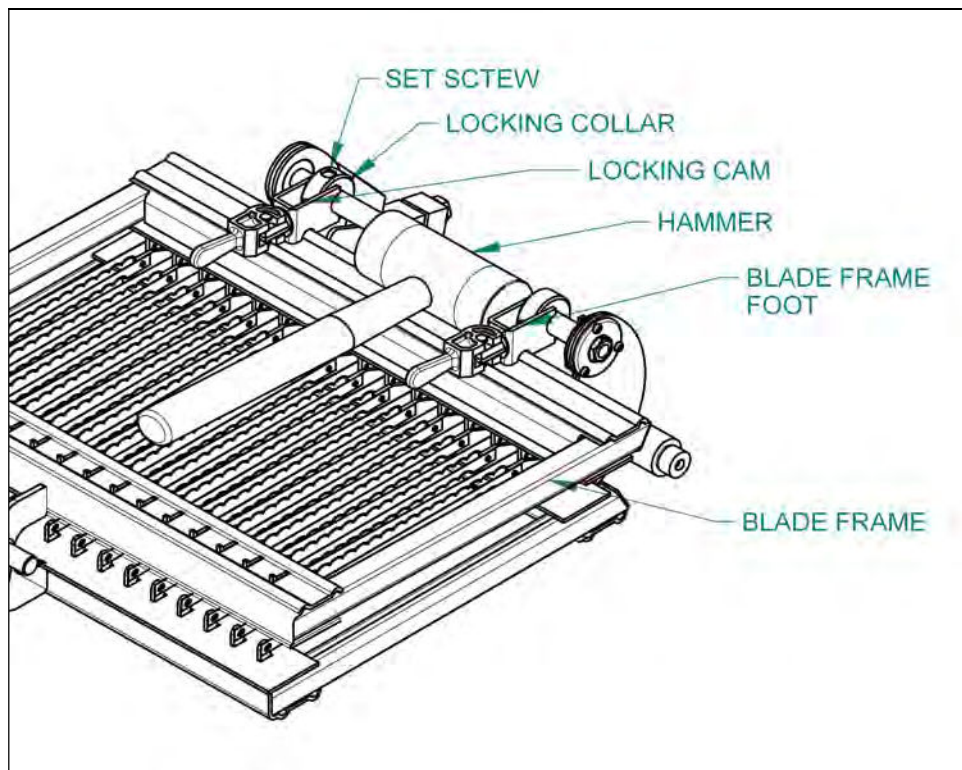

732-N FRONT END SLICER

Adjusting the Clearance Between The Blade Frames

WARNING

ALWAYS DISCONNECT THE SLICER FROM THE POWER SUPPLY BEFORE ATTEMPTING ANY TYPE OF MAINTENANCE TASK.

Start by removing the bagging scoop and the top and front covers by removing their knobs. The distance between the tops of the blade frames is adjusted by rotating the eccentric pins located in front of the blade frames. Two wrenches are used to do this. One wrench is used to keep the eccentric pin from rotating while the second is used to loosen the lock nut on the end of the pin. This nut secures the pin in position once its proper location is determined. See the illustration below.

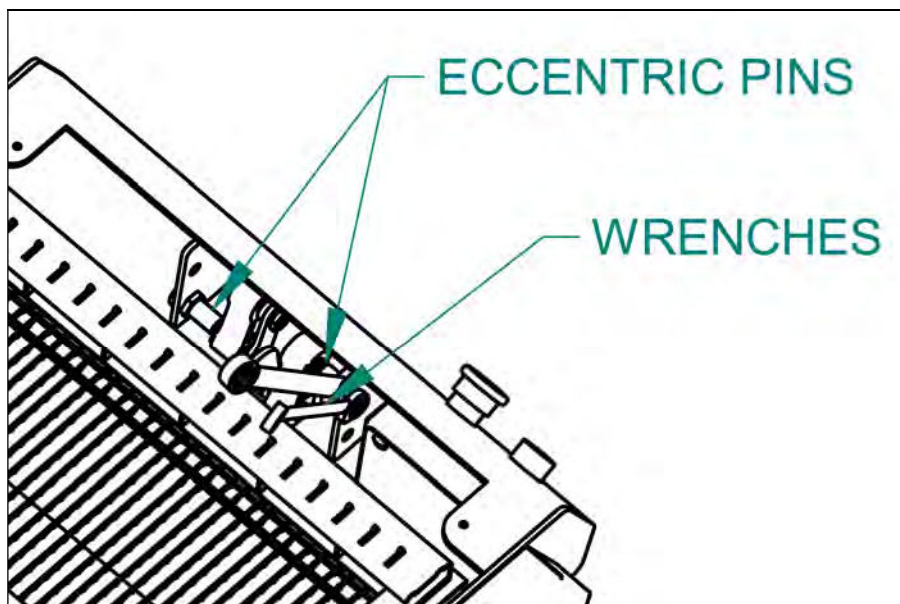

To adjust the eccentric, once the lock nut is loosened, rotate the pin using a wrench, rotating the pin, (it is possible that both pins will need adjustment at the same time), until the knives of the machine are in line, (alternating blades should not appear to be in front of or behind each other when viewed from the side), when the blade frames are half way through their travel or when the rocker shafts are aligned vertically. A straight edge may be used from the dull side of the knives to aid in determining if the knives are in line. When the eccentric pins are in the desired position tighten each of the locknuts to secure the position of the eccentrics. Check the blade frame clearance by turning the driven pulley by hand. Two things may happen if the knives are not inline, the blade frames may hit each other causing a loud knocking noise or the cutting efficiency of the machine may be greatly reduced. Replace all covers before starting the machine.

732-N FRONT END SLICER

Lubrication

WARNING

ALWAYS DISCONNECT THE SLICER FROM THE POWER SUPPLY BEFORE ATTEMPTING ANY TYPE OF MAINTENANCE TASK.

Once a month put a drop of a food approved lubricant on the plastic links at the top of the blade frames. Also add a drop or two to each bushing on the pusher drive cross shaft and lever shaft. All other bearings are either grease packed or sealed and seldom need attention.

NOTE

NEVER OIL OR GREASE THE MOTOR.

Cleaning

Use a mild detergent solution to clean the exterior surfaces and empty the crumb tray daily or as necessary. Periodically remove all covers and brush or blow, (if compressed air is available), all foreign material from all surfaces, especially moving parts.

732-N FRONT END SLICER
RECOMMENDED SPARE PARTS

<u>PART NUMBER</u>	<u>PART DESCRIPTION</u>	<u>NO. REQ'D</u>
5835-7705	Clip-Hairpin	2
0730-0031	Pin-Eccentric	2
0732-0013	Pin-Blade Frame	2
0711-0002	Link-Top	2
6301-3609*	Motor-1/2 HP, 1-60-115/230	1
5601-1127*	Belt-V (4L370) (60 Cycle Machines)	1
5749-8027*	Relay-Power (115 VAC)	1
5749-8028*	Relay-Power (230 VAC)	1
5708-7915	Red "Stop" Pushbutton	1
5708-7931	"Stop" Contact Block	1
5708-7900	Green "Start" Pushbutton	1
5708-7930	"Start" Contact Block	1
5757-8002	Switch-Limit	2
5220-5040	Bearing-Driven Pulley	2
0797-0058-019	Stud-Driven Pulley	1
0797-0071-4	Connecting Rod Assembly with Bearings	1
0797-0057-219	Stud-Swing	1
5220-4040	Bearing-Rocker Shaft	2
5220-0042	Bearing-Swing Shaft	4
0797-0029-1	Knife-Type A	As Req'd.
0777-0970	Bolt-Eye	4
0777-0971	Cam-Clamp	4
5852-0050	Spring-Bellville	4
6084-8700	Gas Spring	1
5840-1106	Clip-Retaining TRUARC	2
5251-0030	Bearing-5/8 Cam Follower	2
5251-0091	Bearing-3/4 Cam Follower	1

***For Other Electrics Contact the Factory**

For Service Parts Call Oliver Products @ 800-253-3893

REV 1-20-09

732-N FRONT END SLICER

MAIN FRAME

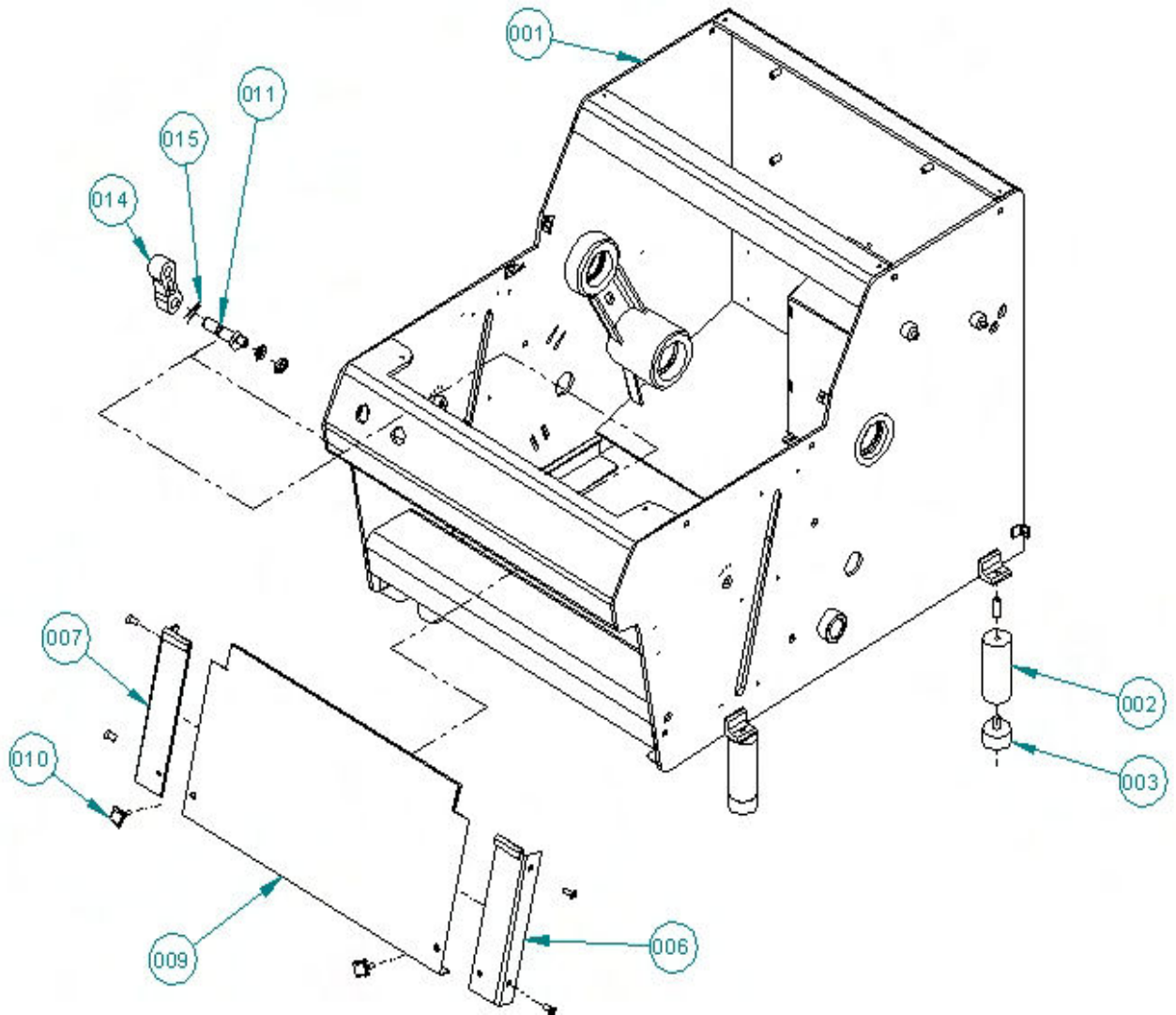

REV 10/3/08

732-N FRONT END SLICER

MAIN FRAME PARTS LIST

ITEM NO	PART DESCRIPTION	PART NUMBER
001	Frame	0732-0002
001	Frame (Black)	0732-0002-002
002	Leg-Extension	0732-0003-001
003	Bumper-Rubber	5902-0036
006	Angle-RH Mounting	0732-0004-0001
007	Angle-LH Mounting	0732-0004-0002
009	Table-Infeed	0711-0048
010	Knob W/Stud M5 x .8 x 15mm LG	5911-7210
011	Pin-Eccentric	0730-0031
014	Link-Blade Frame	0711-0002
015	Clip-Hairpin	5835-7705

NOTE: Bold text represents optional parts available

FOR SERVICE PARTS CALL OLIVER PRODUCTS @ 800-253-3893
 REV. 11/17/15

732-N FRONT END SLICER

COVERS

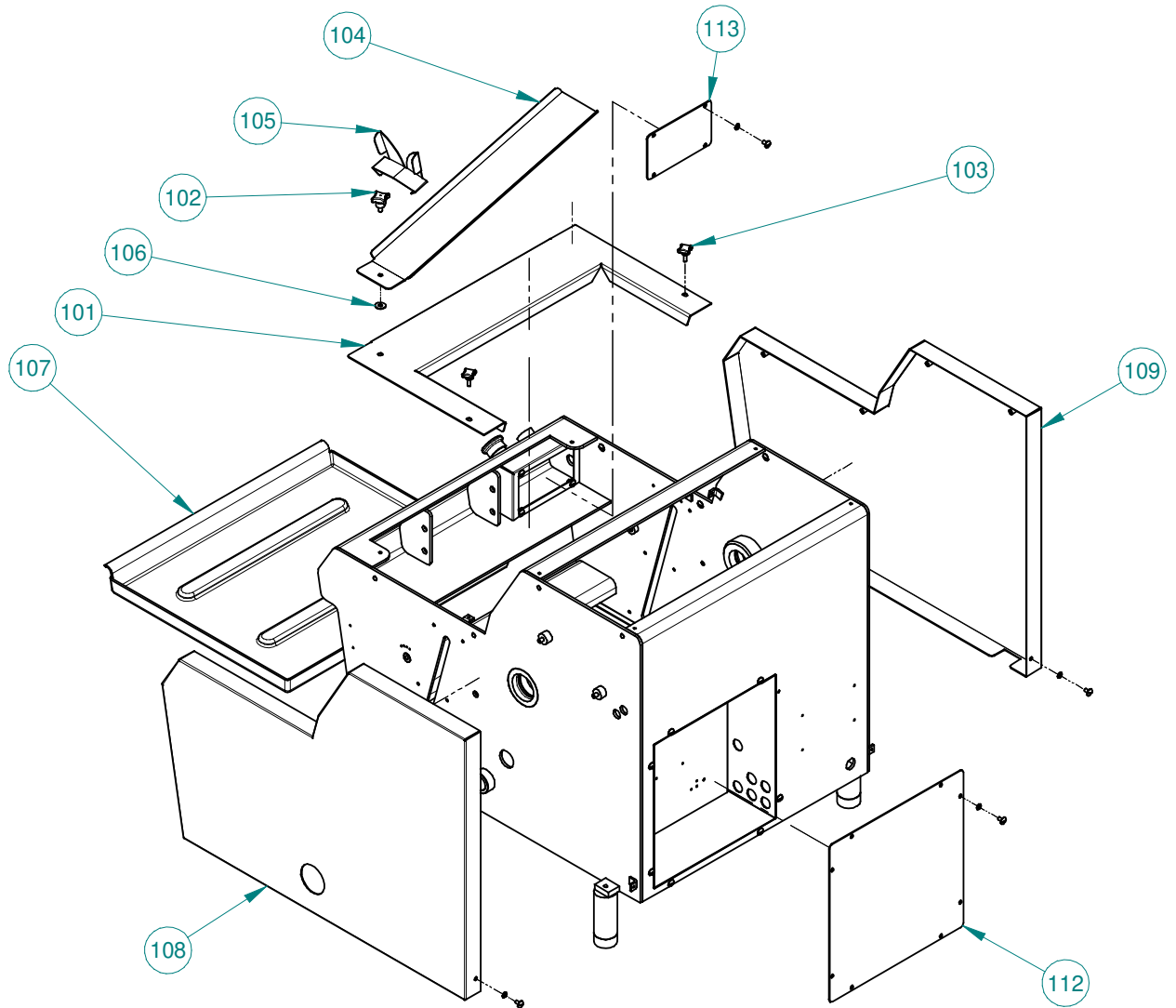

REV. 7/22/04

732-N FRONT END SLICER

COVERS PARTS LIST

ITEM NO	PART DESCRIPTION	PART NUMBER
101	Cover-Front	0732-0005
102	Knob-Clamp W/Stud M6 x 1	4560-2507-18
103	Knob-Clamp W/Stud M5 x .8 x 15MM LG	5911-7210
104	Scoop-Bread	0711-0004-1
105	Stop-Bread	0711-0080
106	Washer-Flat Nylon	5851-8120
107	Tray-Crumb	0711-0014-002
108	Cover-RH Side	0732-0006
108	Cover-RH Side (Black)	0732-0006-002
109	Cover-LH Side	0732-0007
108	Cover-LH Side (Black)	0732-0007-002
112	Cover-Electrical Box	0732-0008
112	Cover-Electrical Box (Black)	0732-0008-002
113	Cover-Switch Enclosure	0732-0009
115*	Guard-Pushbutton	0732-0034

NOTE: Bold text represents optional part available

*Not Shown

FOR SERVICE PARTS CALL OLIVER PRODUCTS @ 800-253-3893
 REV. 11/29/12

**732-N FRONT END SLICER
PUSHER**

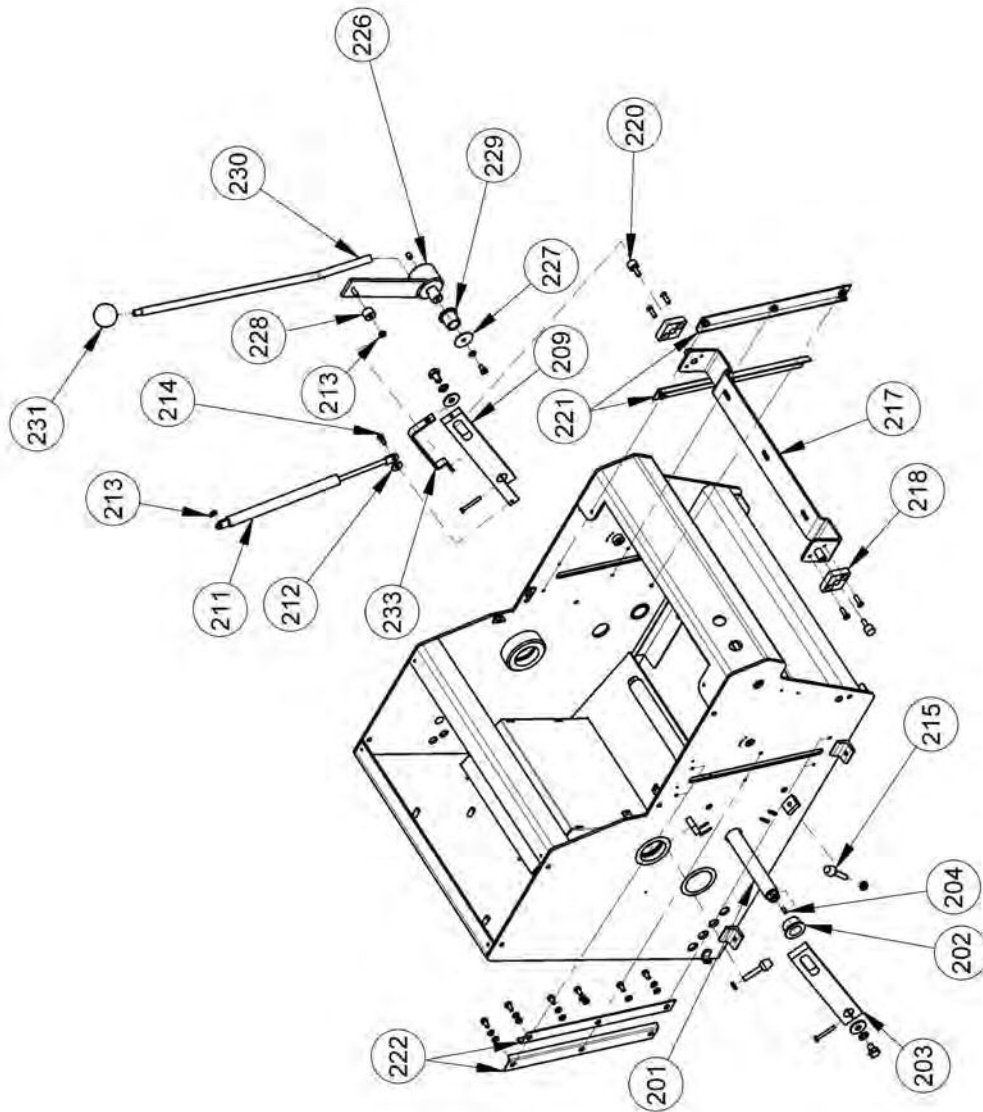

REV. 11/21/08

732-N FRONT END SLICER
PUSHER PARTS LIST

ITEM NO	PART DESCRIPTION	PART NUMBER
201	Shaft-Pusher (Metric)	0732-0010
202	Bearing-Bronze Flange	5254-3043
203	Arm-LH Pusher	0711-0042
204	Key	5824-2316
209	Arm-RH Pusher	0711-0043-2
211	Spring-Gas	6084-8700
212	Spacer-Lower	0711-0021
213	Clip-Push on	5831-8225
214	Screw-Shoulder 1/4 x 1/4	5842-8501
215	Spindle Assembly M8 x 1.25	5902-8795
217	Bracket-Cradle Mounting	0732-0011
218	Block-Slide	0711-0017
220	Bearing-5/8 Dia. Cam Follower	5251-0030
221	Guide-RH Pusher	0711-0051-0001
222	Guide-LH Pusher	0711-0051-0002
226	Hub-Pusher Drive	0732-0023
227	Washer-Special	4655-0309-1603
228	Bearing-3/4 Dia. Cam Follower	5251-0091
229	Bearing-Bronze Flange	5254-3139
230	Lever-Pusher	0732-0024
231	Knob-Ball	5911-7120
233	Keeper	0711-0023

FOR SERVICE PARTS CALL OLIVER PRODUCTS @ 800-253-3893
 REV. 11/21/08

732-N FRONT END SLICER

ROCKER

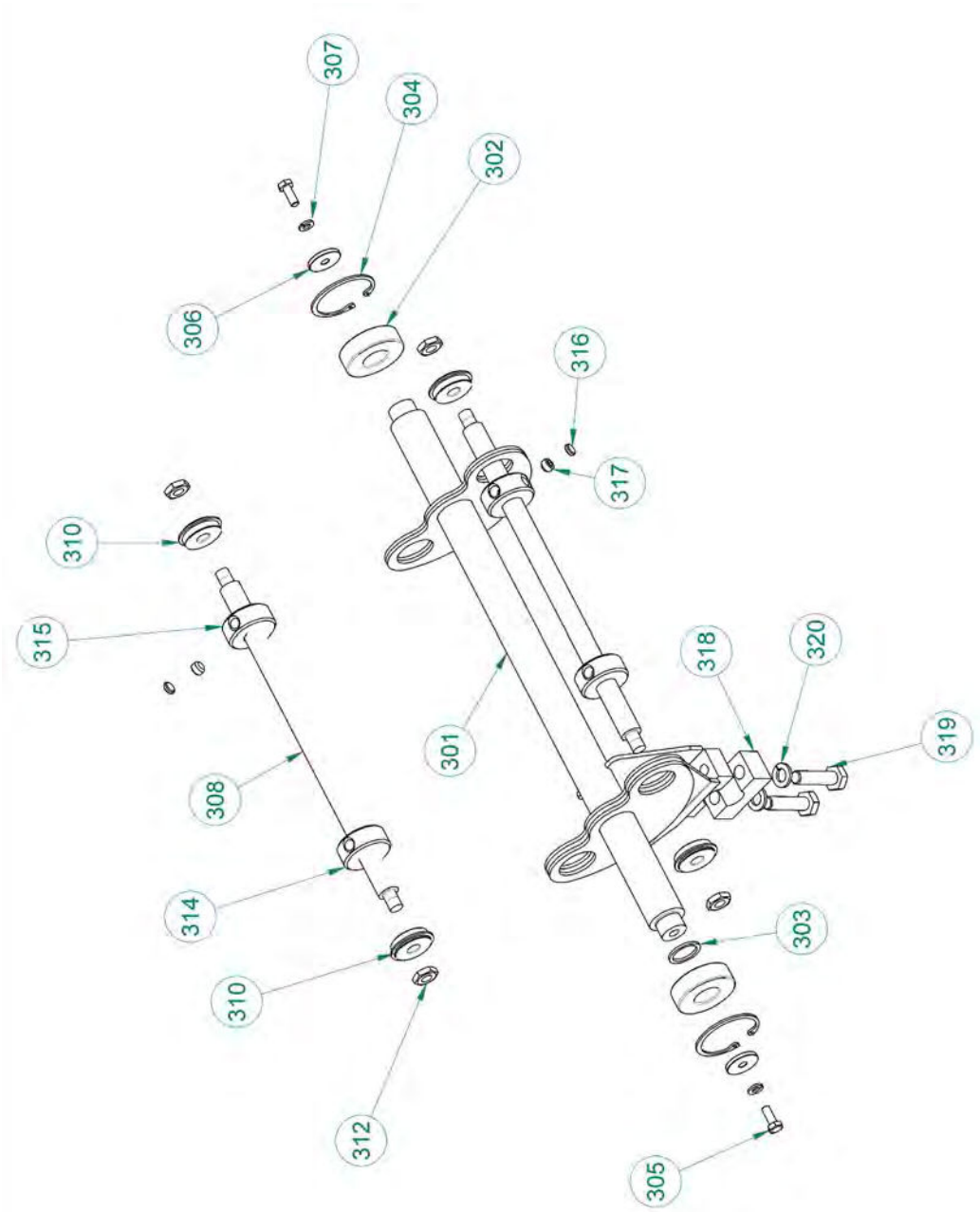

732-N FRONT END SLICER
**ROCKER
PARTS LIST**

ITEM NO	PART DESCRIPTION	PART NUMBER	QUANTITY
301	Frame-Rocker	0732-0012-001	1
302	Bearing-Ball	5220-4040	2
303	Spacer-Bearing	0797-3088-001	1
304	Ring-Retaining	5840-1036	2
305	Screw-Hex Hd M6x16MM	8842-0544	2
306	Washer-Flat- 1x1/4x1/8	8851-8495	2
307	Washer-Spring Lock M6	8851-9414	2
308	Shaft-Swing	0730-0024-001	2
310	Bearing-Ball 10x30x9	5220-0042	4
312	Nut- Hx HD Jam M10x1.5	8832-0418	4
314	Collar-Hold Down	0797-0031-002	2
315	Collar-Locating	0797-0031-004	2
316	Plug-Threaded	5840-8076	2
317	Screw-Socset Cuppt 3/8x1/4	5842-6540	2
318	Cap-Clamp	0730-0023	1
319	Screw- Hx HD M10x40MM	8843-0331	2
320	Washer- Spring Lock M10	8851-9468	2

(All Washers, Screws, & Nuts on this list are Stainless Steel)

FOR SERVICE PARTS CALL OLIVER PRODUCTS @ 800-253-3893

REV. 5-17-24

732-N FRONT END SLICER

DRIVEN PULLEY

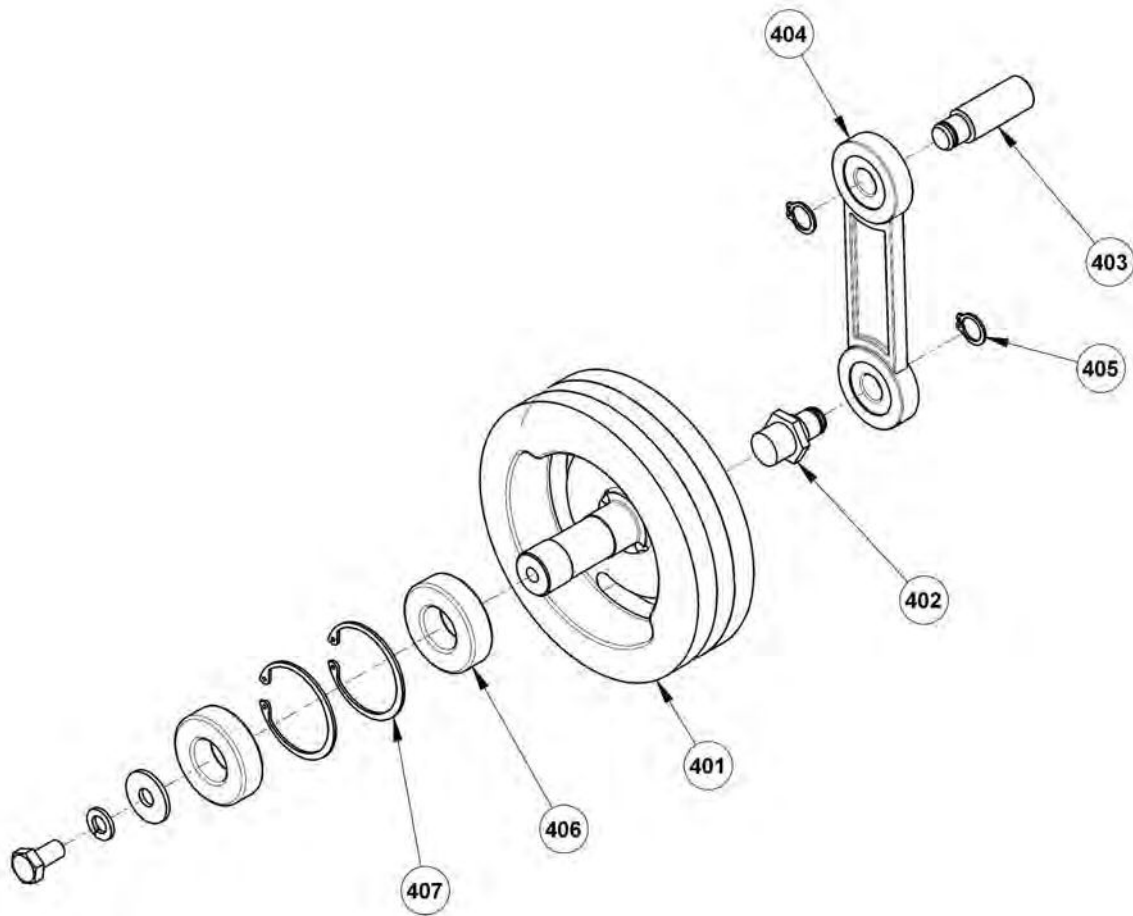

REV. 1/20/09

732-N FRONT END SLICER
DRIVEN PULLEY PARTS LIST

ITEM NO	PART DESCRIPTION	PART NUMBER
401	Pulley-Driven	0730-0005-001
402	Stud	0797-0058-019
403	Stud-Swing	0797-0057-219
404	Rod Assembly W/Bearings	0797-0071-4
405	Ring-Retaining	5840-2825
406	Bearing-Ball	5220-5040
407	Ring-Retaining	5840-1040
408	Washer-Flat M10	8851-8418
409	Washer-Spring Lock M10	8851-9418
410	Screw-Hex HD M10 X 20MM	8842-0583

FOR SERVICE PARTS CALL OLIVER PRODUCTS @ 800-253-3893
 REV. 1/20/09

732-N FRONT END SLICER

SLICE PARTS

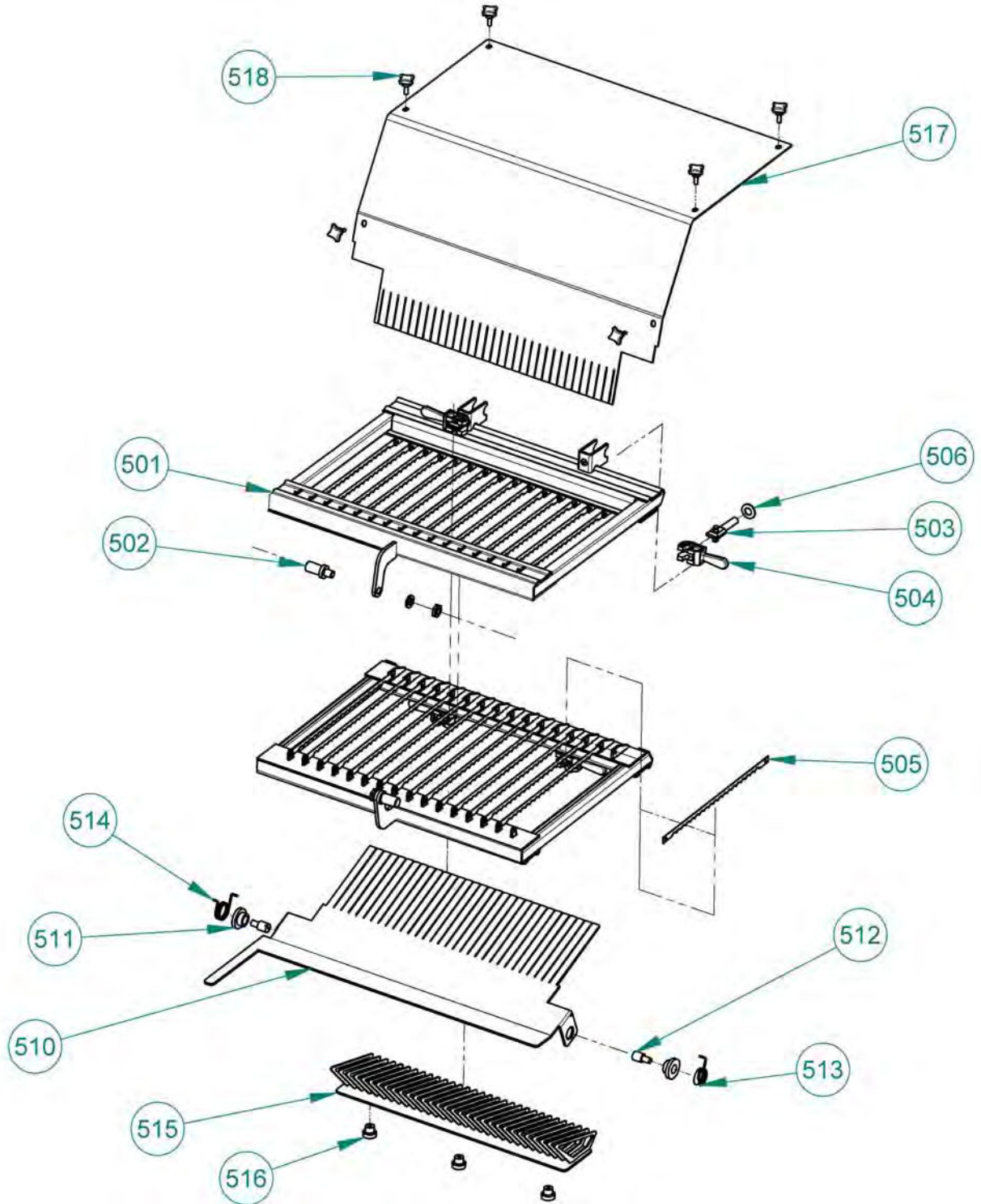

REV. 7/22/04

732-N FRONT END SLICER
SLICE PARTS LIST

ITEM NO	PART DESCRIPTION	PART NUMBER
501*	Blade Frame	0732-0001-5XX
502	Pin-Frame	0732-0013
503	Bolt-Eye	0777-0970
504	Cam	0777-0971
505	Blade-Type A	0797-0029-1
506	Washer-Belleville Spring	5852-0050
510*	Holddown	0711-0036-2XX
511	Bushing	0777-0066
512	Screw-Pivot	0777-0068-001
513	Spring-RH Torsion	7030-0020
514	Spring-LH Torsion	7030-0021
515*	Cradle	0732-0014-1XX
516	Knob-Knurled	5911-7218
517*	Cover-Top	0732-0015-0XX
518	Knob W/Stud M5 x .8 x 15mm Lg.	5911-7210

* Specify Slice Thickness

FOR SERVICE PARTS CALL OLIVER PRODUCTS @ 800-253-3893

Rev. 8/11/04

732-N FRONT END SLICER

ELECTRICAL PARTS

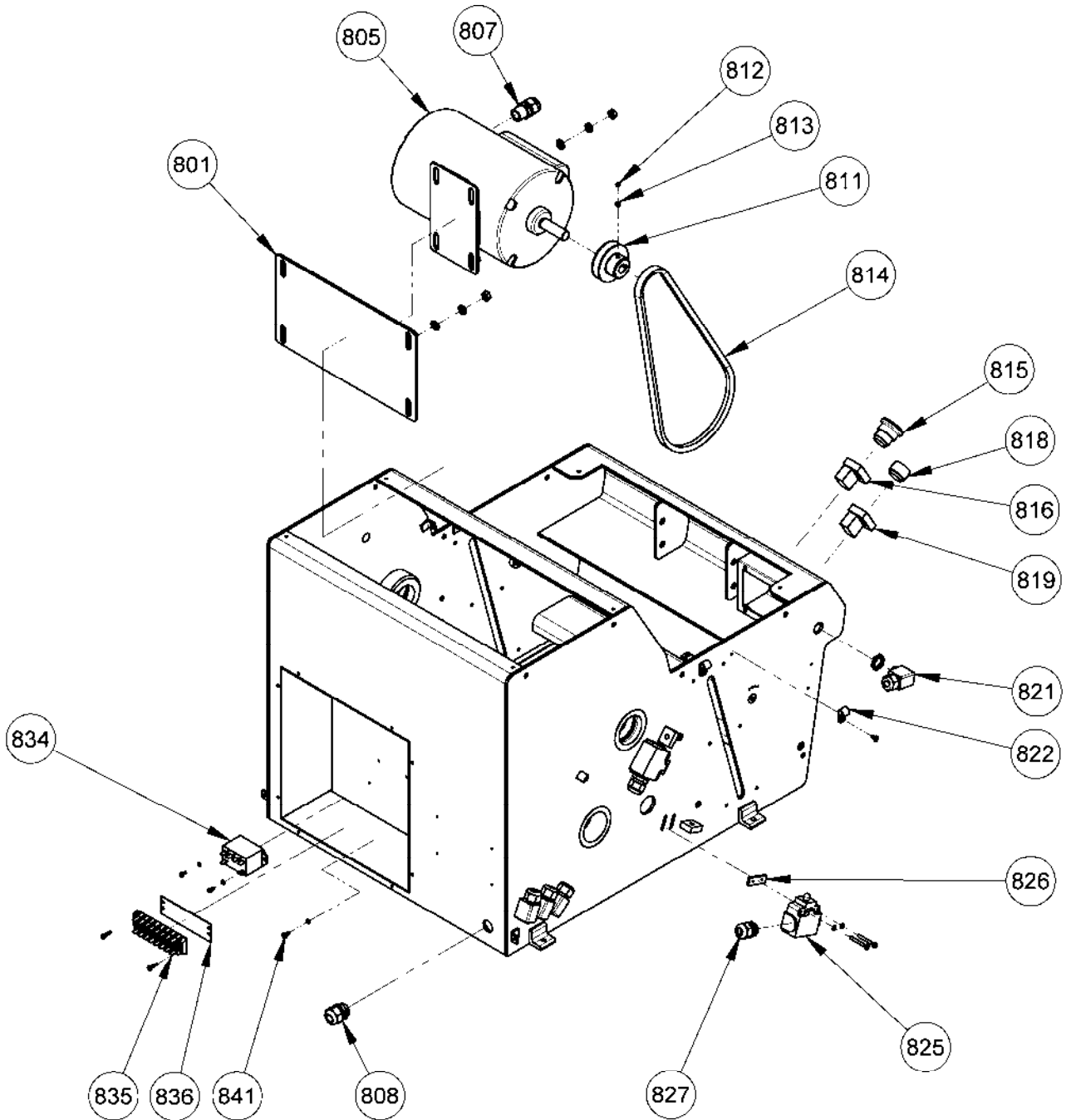

REV. 12/13/05

732-N FRONT END SLICER
ELECTRICAL PARTS LIST

ITEM NO	PART DESCRIPTION	PART NUMBER
801	Plate-Motor Mounting	0732-0016
805*	Motor-1/2 HP 1-60-115/230	6301-3609
805*	Motor-1/2 HP 1-50-110/220	6301-3940
807	Bushing-Strain Relief	5765-1082
808	Bushing-Strain Relief	5765-1120
811	Pulley-V Belt (60 Hz Machines)	0732-0018
811	Pulley-V Belt (50 Hz Machines)	0732-0018-002
812	Rod-Nylon Threaded 1/4-20	5840-8074
814	Belt-V 4L370	5601-1127
815	Button-Red Stop	5708-7915
816	Block-"Stop" Contact	5708-7931
818	Button-Green Start	5708-7900
819	Block "Start" Contact	5708-7930
821	Bushing-Strain Relief	5765-1010
822	Clamp-Cable	5765-4232
825	Switch-Limit	5757-7357
826	Nutbar-Switch Mounting	0732-0020
827	Bushing-Strain Relief	5765-1110
834	Relay-Power 1-50/60-110/115	5749-8027
834	Relay-Power 1-50/60-220/230	5749-8028
835	Block-Terminal	5770-7451
836	Strip-Marker	5770-7328
838	Plug-Hole	5769-3008
841	Green Grounding Screw 6-32 3/8"	5841-9501

* For other Electrics Consult the Factory

Continued

FOR SERVICE PARTS CALL OLIVER PRODUCTS @ 800-253-3893

REV 10/5/06

732-N FRONT END SLICER
ELECTRICAL PARTS LIST (Continued)
Items Not Shown On Drawing

ITEM NO	PART DESCRIPTION	PART NUMBER
806	Cord-Motor	0732-0017
817	Wire-Switch Jumper	0711-0059
820	Cord-Pushbutton	0732-0019
830	Cord-Stop Limit Switch	0732-0021
831	Cord-Start Limit Switch	0732-0022
832*	Cord Power 1-60-115	0711-0056
832*	Cord Power 1-60-230 & 1-50-110/220	0711-0056-001
833	Harness-Wire	0711-0057
838	Plug-Hole	5769-3008
839*	Nameplate-Wiring Diagram (Single Phase)	6402-3103
840	Plug-Power 1-60-230	5765-2030
843	Plug-Hole	5769-3013

* For other Electrics Consult the Factory

FOR SERVICE PARTS CALL OLIVER PRODUCTS @ 800-253-3893

REV. 12/13/05

732-N FRONT END SLICER WIRING DIAGRAM 1-60-115/230 & 1-50-110/220

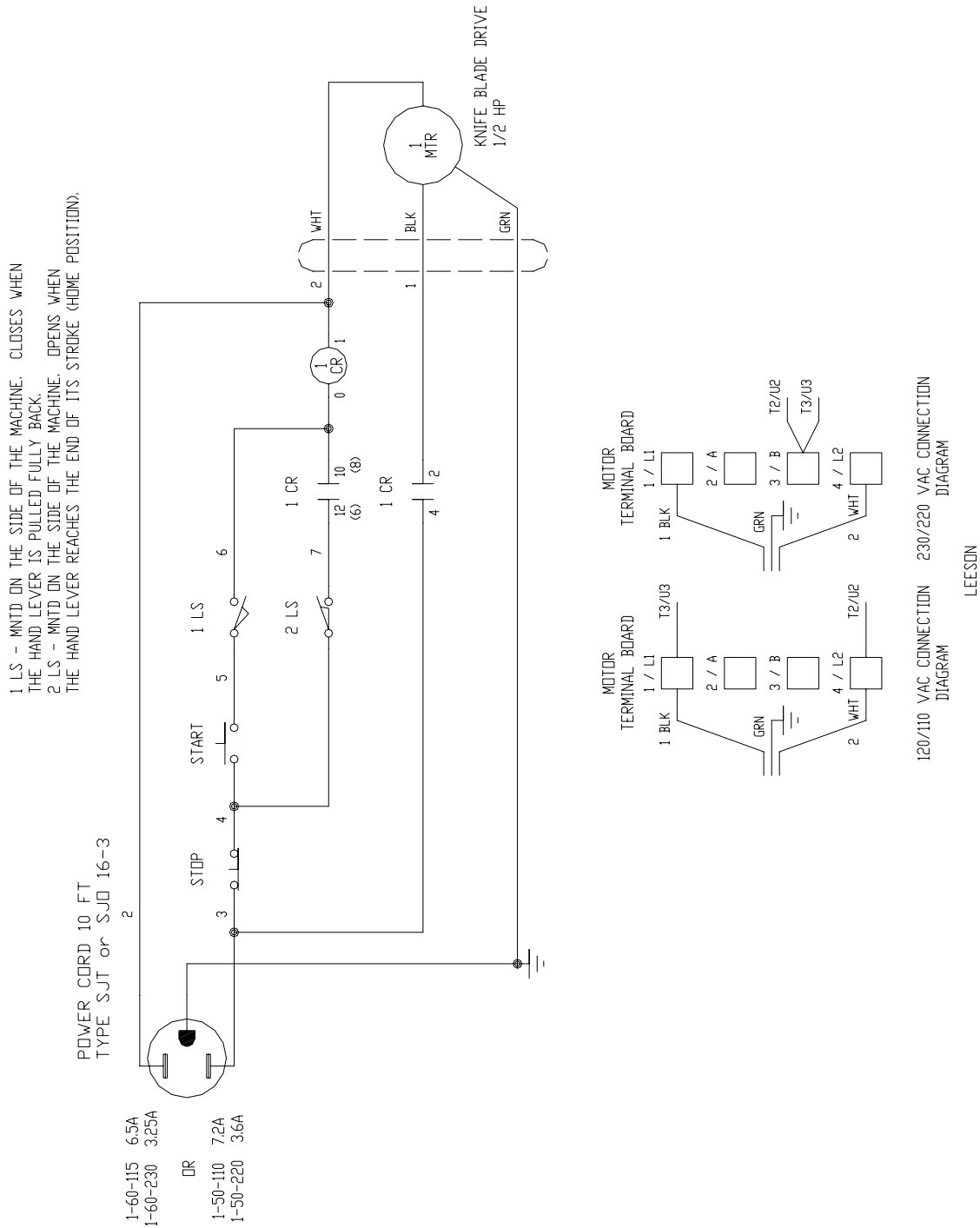

- For other Electrics Consult the Factory

WARRANTY

PARTS

Oliver Packaging & Equipment Company warrants that if any part of the equipment (other than a part not manufactured by Oliver) proves to be defective (as defined below) within two years after shipment, and if Buyer returns the defective part to Oliver Packaging & Equipment within two years, Freight Prepaid to Oliver Packaging & Equipment's plant in Grand Rapids, MI, then Oliver Packaging & Equipment, shall, at Oliver Packaging & Equipment's option, either repair or replace the defective part, at Oliver Packaging & Equipment's expense.

LABOR

Oliver Packaging & Equipment further warrants that equipment properly installed in accordance with our special instructions, which proves to be defective in material or workmanship under normal use within two (2) years from installation or two (2) years and three (3) months from actual shipment date, whichever date comes first, will be repaired by Oliver Packaging & Equipment or an Oliver Packaging & Equipment Authorized Service Dealer, in accordance with Oliver Packaging & Equipment's published Service Schedule.

For purposes of this warranty, a defective part or defective equipment is a part or equipment which is found by Oliver Packaging & Equipment to have been defective in materials workmanship, if the defect materially impairs the value of the equipment to Buyer. Oliver Packaging & Equipment has no obligation as to parts or components not manufactured by Oliver Packaging & Equipment, but Oliver Packaging & Equipment assigns to Buyer any warranties made to Oliver Packaging & Equipment by the manufacturer thereof.

This warranty **does not** apply to:

1. Damage caused by shipping or accident.
2. Damage resulting from improper installation or alteration.
3. Equipment misused, abused, altered, not maintained on a regular basis, operated carelessly, or used in abnormal conditions.
4. Equipment used in conjunction with products of other manufacturers unless such use is approved by Oliver Packaging & Equipment in writing.
5. Periodic maintenance of equipment, including but not limited to lubrication, replacement of wear items, and other adjustments required due to installation, set up, or normal wear.
6. Losses or damage resulting from malfunction.

The foregoing warranty is in lieu of all other warranties expressed or implied AND OLIVER PACKAGING & EQUIPMENT MAKES NO WARRANTY OF MERCHANTABILITY OR FITNESS FOR PURPOSE REGARDING THE EQUIPMENT COVERED BY THIS WARRANTY. Oliver Packaging & Equipment neither assumes nor authorizes any person to assume for it any other obligations or liability in connection with said equipment. OLIVER PACKAGING & EQUIPMENT SHALL NOT BE LIABLE FOR LOSS OF TIME, INCONVENIENCE, COMMERCIAL LOSS, INCIDENTAL OR CONSEQUENTIAL DAMAGES.

WARRANTY PROCEDURE

1. If a problem should occur, either the dealer or the end user must contact the Parts and Service Department and explain the problem.
2. The Parts and Service Manager will determine if the warranty will apply to this particular problem.
3. If the Parts and Service Manager approves, a Work Authorization Number will be generated, and the appropriate service agency will perform the service.
4. The service dealer will then complete an invoice and send it to the Parts and Service Department at Oliver Packaging & Equipment Company.
5. The Parts and Service Manager of Oliver Packaging and Equipment Company will review the invoice and returned parts, if applicable, and approve for payment.



3236 Wilson Drive NW, Walker, MI 49534
800-253-3893 | www.oliverquality.com

RETURNED PARTS POLICY

This policy applies to all parts returned to the factory whether for warranted credit, replacement, repair or re-stocking.

Oliver Packaging and Equipment Company requires that the customer obtain a Return Material Authorization (RMA) number before returning any part. This number should appear on the shipping label and inside the shipping carton as well. All parts are to be returned prepaid. Following this procedure will insure prompt handling of all returned parts.

To obtain an RMA number contact the Repair Parts Department toll free at (800) 253-3893.

Parts returned for re-stocking are subject to a **RE-STOCKING CHARGE**.

Thank you for your cooperation,

Repair Parts Manager
Oliver Packaging and Equipment Company