



Walker, Michigan, U.S.A. 49534-7564

USER'S OPERATING AND INSTRUCTION MANUAL

MODEL 860L

DOUGH MOULDER

860L Bread & Roll Moulder **OPERATOR'S MANUAL**

**SAFETY INSTRUCTIONS, MAINTENANCE & TROUBLE SHOOTING,
PARTS LIST, DIAGRAMS & WARRANTY**

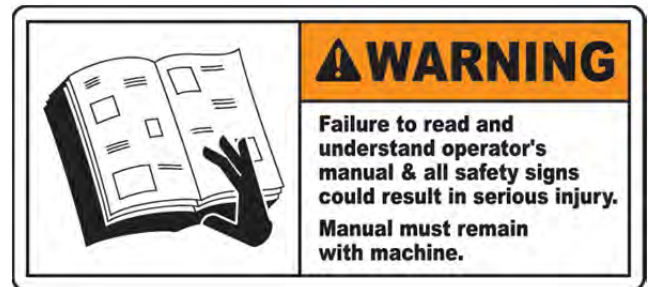

**SAFETY
DEPENDS ON YOU!**

DO NOT INSTALL, OPERATE OR DO MAINTENANCE OF THIS EQUIPMENT WITHOUT READING THE MANUAL. PROTECT YOURSELF AND OTHERS BY OBSERVING ALL SAFETY INFORMATION AND PROCEDURES. FAILURE TO COMPLY WITH INSTRUCTIONS COULD RESULT IN INJURIES AND/OR PROPERTY DAMAGES.

RECEIVING, UNCRATING & UNPACKING

This machine was carefully manufactured, tested and crated prior to shipment. When receiving, carefully inspect this machine for any shipping damage and report this to the carrier. When unpacking, ensure that all packing materials are removed prior to use. Make sure any bolts or parts that may have loosened during transit are tightened before proceeding.



SAFETY INSTRUCTIONS



ELECTRICAL SAFETY

WARNING! ELECTRICAL SHOCK CAN KILL

- INSTALL EQUIPMENT IN ACCORDANCE WITH THE NATIONAL ELECTRICAL CODE AND ALL LOCAL ELECTRICAL CODES.
- IMPROPER CONNECTION OF THE EQUIPMENT GROUNDING CONDUCTOR AND LINE VOLTAGE CAN RESULT IN A RISK OF ELECTRIC SHOCK AND/OR DAMAGE TO EQUIPMENT. RESULTING DAMAGE IS NOT COVERED BY THE WARRANTY.
- CHECK WITH A QUALIFIED ELECTRICIAN TO ENSURE THAT THE OUTLET IS PROPERLY GROUNDED. DO NOT MODIFY THE CORD OR PLUG PROVIDED.
- DISCONNECT MACHINE FROM SUPPLY CIRCUIT BEFORE PERFORMING CLEANING, MAINTENANCE OR SERVICING ELECTRICAL CIRCUITS.
- **WARNING! ELECTRONICALLY ENERGIZED CIRCUIT** For machines ordered with the electronic speed control, the Master Power Switch must be turned on to power up the machine at the beginning of the day and turned off when the days production is completed. Use the Stop/Start stations on either side of the machine for production runs.

If the machine turns off unexpectedly for any reason wait 5 minutes before restarting the machine.



GENERAL SAFETY INSTRUCTIONS

WARNING! TO AVOID SERIOUS PERSONAL INJURY, INJURY TO OTHERS AND DAMAGE TO THE EQUIPMENT OR PROPERTY:

1. **Read** the Operators Manual carefully. Be thoroughly familiar with the controls and the proper use of the equipment. Do not discard these instructions. Maintain these in a safe place for continuous reference and training.
2. **Only persons** well acquainted with these rules for safe operation should be allowed to use this machine.
3. **Do not** wear loose clothing, scarves, or neckties. These items may become caught in moving parts and result in personal injury.
4. **Visually** inspect machine prior to starting motor. Ensure all safety guards, covers and devices are in position and in good working condition. Keep hands, hair, clothing and tools away from rollers, V-belts, conveyor belts and all other moving parts when starting, operating or repairing equipment.
5. **Do not** reach into the hopper at any time with power connected to the machine. Pushing down on the red safety bar, will disconnect power to the motor and shut the machine off. To turn the machine off after a production run, use the on/off switch and not the inter-lock switch connected to the in-feed hopper. Do not disconnect interlock switch from the safety bar or render it inoperable by tying, wedging, locking or taping it in a fixed position. The safety system is there for your protection!

6. **Disconnect** machine from supply circuit before performing cleaning, maintenance or servicing electrical circuits or removing stalled dough pieces. In some cases it may be necessary to remove safety guards to perform required maintenance. Immediately replace guards before placing the machine into service.
7. **Turn off** machine before unplugging. Do not unplug machine and do not attempt to move the machine by pulling on the electrical cord.
8. **Do not** operate machine when children are near and disconnect power supply when unattended.
9. **STAY ALERT!** Watch what you are doing and use common sense. Do not use the machine when you are tired, distracted or under the influence of drugs, alcohol or medication.

WELCOME TO BLOEMHOF

You have just purchased the best BREAD & ROLL MOULDER money can buy.

We invite you to read the instructions in order to obtain maximum performance, safety and satisfaction from this outstanding unit. Do not discard these instructions. Maintain these in a safe place for continuous reference and training.

The 860L will be a welcome addition to your shop since it was designed to reduce the labour intensive and tedious moulding operations and produce the finest quality products.

The 860L features:

- Gentle spring loaded roller system
- Double pressure plate controls front and back
- Quick adjustable in-feed guides
- Fully adjustable side guides
- Oversized non-stick dough rollers with rust free scrapers
- Heavy duty motor and drive system
- Sanitary construction

The instructions are in general because of the nationwide distribution of the 860L, personal preference with regards to dough consistency, bread types and most important, customer formulas



BE SURE TO PREPARE YOUR PRESSURE PLATE WELL BEFORE THE FIRST USE!

The fabric surfaces of the pressure plates and return plate should be conditioned or seasoned before the first use. Remove the pressure plate(s) and return plate from the moulder and rub flour into the fabric evenly. Turn over the plate(s) and tap out excess flour. This will condition the fabric to reduce dough sticking. Once done, reinstall the plate(s) as per instruction and start moulding. See pressure plate removal instructions on following pages.



MACHINE DESCRIPTIONS

The instructions are in general because of personal preference with regards to dough consistency, bread types and most important, customer formulas.

Before starting your new moulder, read through the instructions and we'll discuss the features on this unit and the function of the various controls.



DANGER!
KEEP HANDS CLEAR
FROM DOUGH ROLLERS.

**STOP MACHINE BEFORE
REMOVING DOUGH PIECES**

860 & 860L MOULDER OPERATING POINTS

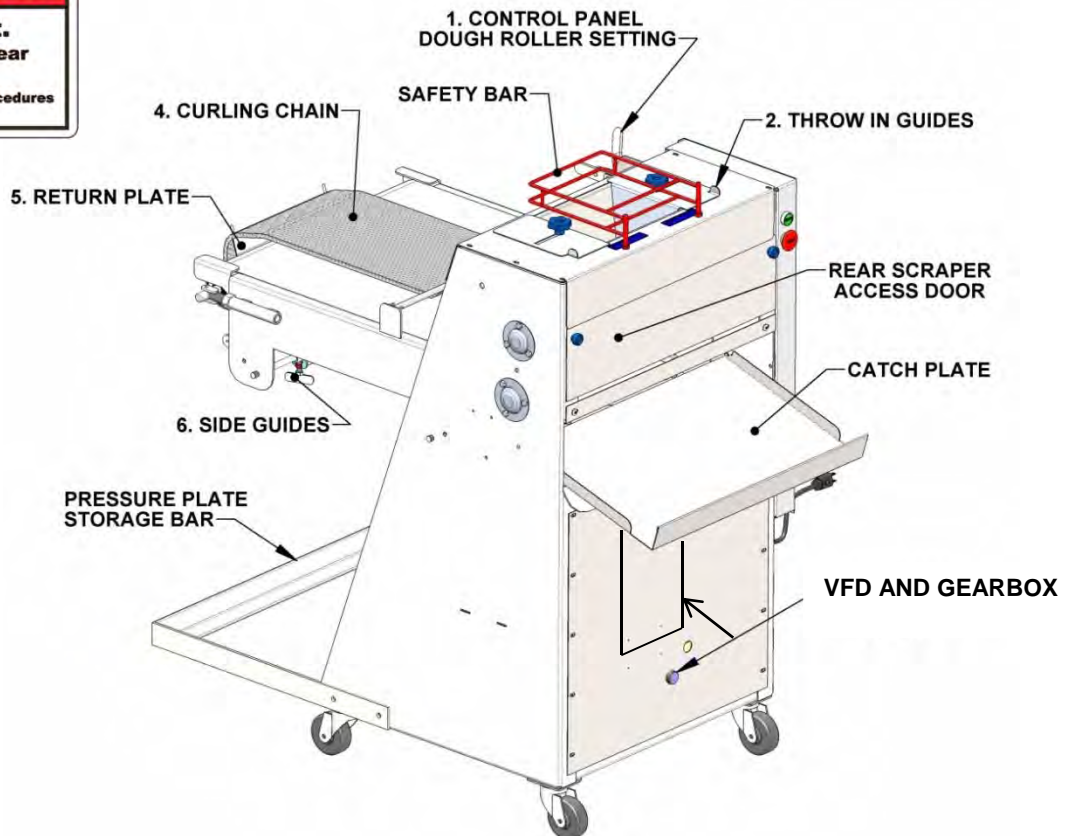
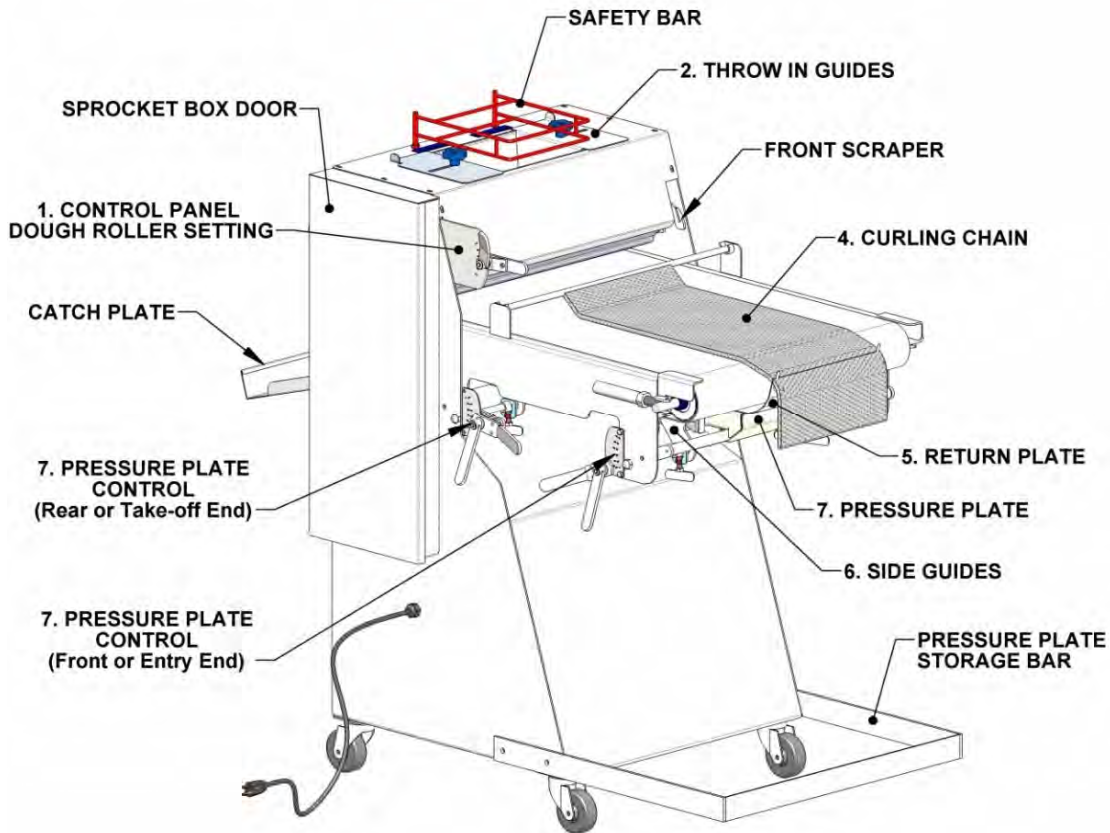

OPERATING INSTRUCTIONS



DANGER!
KEEP HANDS CLEAR
FROM DOUGH ROLLERS.

STOP MACHINE BEFORE REMOVING DOUGH PIECES

1. SAFETY BAR

The red safety bar is attached to a safety interlock switch. **DO NOT** reach into the hopper at any time with power connected to the machine. Pushing down on the red safety bar, will disconnect power to the motor and shut the machine off. To turn the machine off after a production run, use the on/off switch and not the inter-lock switch connected to the in-feed hopper.

WARNING! TEST RED SAFETY BAR INTERLOCK DAILY



Test the safety bar function daily before using the moulder. If pressing down on the safety bar half ways fails to stop the machine or it restarts upon release, disconnect the power supply, tag, lock out the power plug and contact a qualified service technician. Do not disconnect interlock switch from the safety bar or render it inoperable by tying, wedging, locking or taping it in a fixed position. Test the safety bar function daily before using the moulder. The safety system is there for your protection!

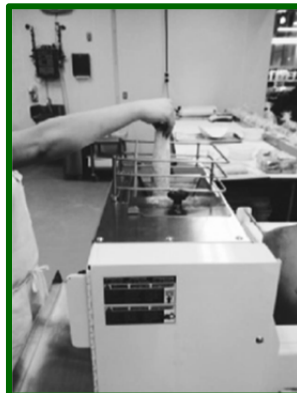

CORRECT
LOAD DOUGH
WITH HANDS
ABOVE THE
SAFETY BAR.

DO NOT REACH
INTO HOPPER
AT ANY TIME!



DANGER!
DO NOT REACH
INTO HOPPER!

PINCH POINT

KEEP HANDS
CLEAR OF
ROLLERS

2. ON/OFF SWITCH

The on/off switch is located at the back of the machine on the catch tray side. The emergency stop button stops all machine functions. The motor reset circuit protects the machine from overloads. If the moulder stops from overloading, let the motor to cool for 5 minutes before resetting the switch and restarting the machine.

3. CONTROL PANEL DOUGH ROLLER SETTING

Your new 860L utilizes a unique spring loaded dough roller system for all your moulding operations. These dough rollers are designed to eliminate excess stress during the moulding process. Stress free moulding basically means that the dough piece is being thoroughly degassed, but not punished during this operation. With fixed rollers, the dough must conform to the gap set between the rollers and therefore is squeezed under excessive pressure. Our spring loaded rollers conform to your dough to prevent tearing and provide an increase in oven jump.

When moulding bread or buns, the handle on the control panel should be moved to a certain number. As a starting point, we recommend that this handle be set at number 2 or 3 for breads.

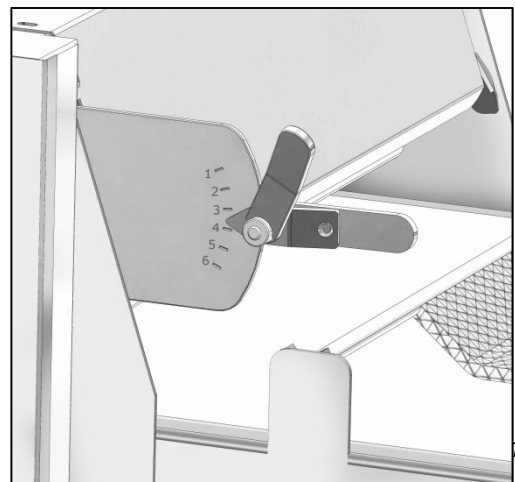

860L DOUGH MOULDER

You will note that regardless of what setting is chosen, the dough rollers are closed. However, the force of the dough going through the rollers will open them, degassing the dough piece.

The number that the control panel handle will be set at, will vary according to the consistency and formulas of the product being moulded. Since softer dough requires less spring tension than stiff dough, the control panel will be set at a smaller number for soft dough. As long as the surface of your dough is not torn, after passing through the dough rollers, more spring tension on the dough rollers can be applied by setting the handle to a larger number on the control panel. However, the dough piece **MUST** be totally curled up when it enters the return plate at the end of the curling chain. If not, put the control panel handle to a smaller number.

When dough pieces stalls on top of the dough rollers, it indicates that the surface of the dough is too dry. Do not dust the dough with flour and if the problem persists, keep the raw dough covered or spray dough pieces lightly with water before moulding.

4. THROW IN GUIDES

The throw-in guides and scaled markings are located on the top of the machine above the dough rollers. These guides are designed to center the dough piece down the center of the conveyor belt and pressure plate. The width of the larger dough pieces can be regulated by moving these throw-in guides closer together or farther apart. These guides must always be evenly divided from the center.

When the roll of dough enters the pressure plate underneath the machine, it must not be longer than the width of the pressure plate. If it is longer than the width of the pressure plate, small ends of the dough piece may be pinched off by the side guides. To correct this problem, position the throw-in guides closer together in order to sheet a narrower dough piece.

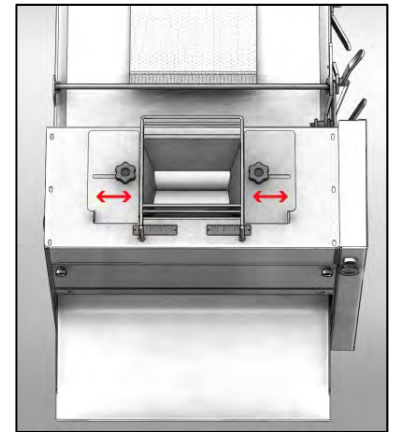

5. THROW IN GUIDES, *Adjustment for Narrow Pressure Plates*

- Adjust the dough guides equally from the center.
- Remove curling chain from the moulder.
- Drop one dough piece into the dough roller and stop machine when the dough piece is on the conveyor belt. Measure the dough piece across the width. This measurement must not be wider than the width of the pressure plate. If the dough piece is wider than the width of the pressure plate, move the dough guides closer together in order to stream a narrower piece of dough.
- Repeat above step until the correct setting is achieved.
- When the correct setting is achieved, re-install curling chain.

NOTE: If dough consistency will not allow for the dough to stream through the dough guides to the required width, in other words the dough stalls in the dough guides, allow slightly more dough rest time before moulding. Other options are to squeeze the dough into an elongated form or slightly pulling the dough apart with both hands, in order to obtain an elongated form prior to dropping into the dough rollers.

6. CURLING CHAIN

The curling chain is equipped with small “starter chains” which should always be touching the belt. If the dough stalls under the curling chain, the surface of the dough is too dry. Do not dust the dough. Spray the dough pieces lightly with water before dropping into the dough rollers. The curling chain should always be anchored over the return plate hooks. However, some slack (3 to 6 links), must be maintained on the curling chain to allow the dough piece to enter the return plate without undue stress. To determine this setting, set gap between belt roller and return plate for dough size and stretch curling chain over the return plate hooks. Provide from 3 to 6 links of slack, before positioning curling chain on these hooks.

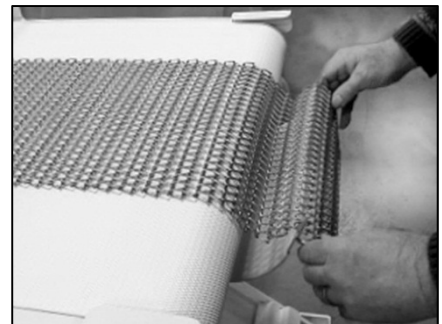

7. RETURN PLATE

860L DOUGH MOULDER

The return plate can be moved in or out of the pressure plate by loosening the wing bolt located at the front or entry end, of the pressure

plate. When small dough pieces are being moulded, the return plate should be moved closer to the belt roller otherwise the small dough piece may simply sit idle in the return plate. When large pieces are being moulded and to prevent stalls at the top of the return plate, the return plate should be moved further away from the belt roller. For 20 ounces, this gap should be about 2 ½”.

8. SIDE GUIDES

The side guides are normally positioned against the pressure plate. However, a space between the side guides and pressure plate will provide a dog bone appearance and a straighter loaf of bread by forming more dough on both ends of the dough piece. If this is preferred, we suggest a ¾” gap (2 cm) between both side guides and the pressure plate, front to back. If large crumbs occur, the dough piece may be longer than the width of the pressure plate, causing the dough to be pinched by the side guides. (See *Throw-In Guides*) Crumbs may also result if the pressure plate is too close to the belt, forcing the dough past the side guides.



Too much gap between the side guides and conveyor belt (due to wear or maladjustment) may also cause large crumbs. If the side guides need re-adjustment, clean belt with plastic scraper and remove pressure plate. Loosen nuts and bolts that hold side guide plastic to metal side guide and insert 1/16” spacer in between the top of the side guides and the conveyor belt, front to back. Push side guides against the spacers and re-adjust the nut against the side guides. Tighten nuts and bolts securely.

Adjusting the side guides too close to the conveyor belt will cause premature belt/side guide wear and will stall the motor. Belt wear due to side guide maladjustment is not covered by warranty.

ADJUSTING & CHANGING PRESSURE PLATES



DISCONNECT POWER BEFORE REMOVING PRESSURE PLATE
DO NOT allow the pressure plate to contact the conveyor belt
at any time, belt damage will result.

Proper Pressure Plate Adjustment

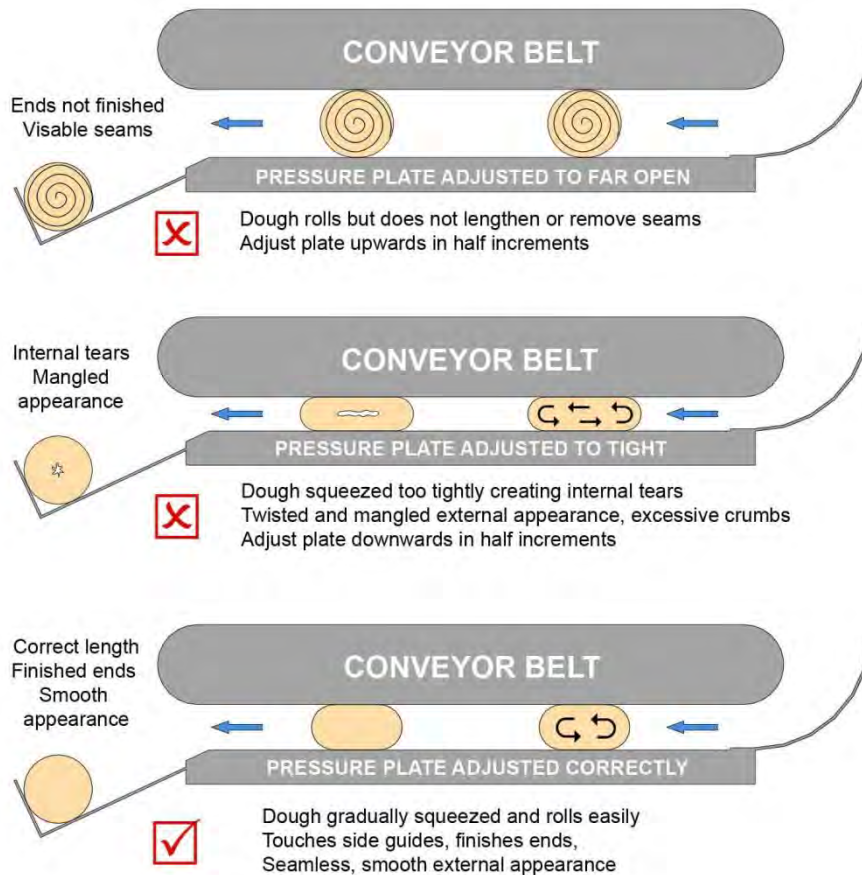

To adjust the pressure plate up or down, loosen the clamping handle and adjust the pressure plate handle up or down. When the desired setting is found, retighten clamp. Adjust the return plate accordingly.

9. **PRESSURE PLATE** (Condition fabric by dusting with flour before use)

The pressure plate can be adjusted up or down at both the front and back ends of the pressure plate. For the majority of products, the pressure plate should be parallel to the conveyor belt, or slightly closer to the conveyor belt at the take-off end. Never adjust the pressure plate closer to the conveyor belt at the entry end than at the take-off end, as this will mangle the dough piece.

To adjust the pressure plate up or down, stand in-front of the two black pressure plate handles. To adjust the front or entry side, of the pressure plate, loosen the right clamping handle, and adjust the pressure plate handle up or down. When the desired setting is found, retighten clamp. For adjusting the back or the take-off end of the pressure plate, loosen the left clamping handle and follow the same procedure. Before using the machine, always insure the pressure plate settings are correct for the weight of dough being processed.

CAUTION! PREMATURE FABRIC WEAR ON THE PRESSURE PLATE WILL RESULT IF THE PRESSURE PLATE IS ALLOWED TO COME INTO CONTACT WITH THE CONVEYOR BELT

a. **PRESSURE PLATE SETTINGS**

We suggest the pressure plate handles be set at 3 ½ on the numbered plates, for 20 ounce (570 gm) pan bread. However, the actual settings will vary based on product weight, formula and desired product length. If the outer appearance of the dough piece is rough, it usually is an indication that the pressure plate is too close to the belt. The actual settings will depend on dough consistency, proof time (if any) and weight ranges.

860L DOUGH MOULDER

b. PRESSURE PLATE REMOVAL

To remove pressure plate, remove curling chain from return plate hooks, loosen return plate bolt on pressure plate and pull the return plate out of the pressure plate. Loosen both pressure plate clamping handles and adjust pressure plate to lowest setting. While standing at the side of the machine, slide pressure plate forward about 2 inches to release the plate hooks from the pressure plate support bars. With one hand on either end of the pressure plate, lift plate and pull out of the machine towards the catch tray, over the pressure plate supports. The pressure plate hooks attached to the plate, must be lifted over the pressure plate support bars during installation and removal of a pressure plate.

When side guides are installed, it may be necessary to loosen the side guides to allow the plate to be removed. Pressure plates supplied with the **pressure plate adjustment bolt**, require more diligence for removal and installation. Make sure the pressure plate is **properly seated** when repositioned in the 860/860L Moulder.

PRESSURE PLATE CHANGING

Interchangeable pressure plate are available from your Bloemhof dealer in different widths for making various products.

860L 3½", 4¼", 5¼", 6½", 8", 9¼", 10½", 12", 14", 16", 18" and 20"

Curved pressure plates available for tapered products



DISCONNECT MACHINE FROM POWER SOURCE. LIFT OFF CURLING CHAIN



REMOVE RETURN PLATE



LOWER PRESSURE PLATE



LIFT PRESSURE PLATE



SLIDE OUT PRESSURE PLATE



STORE PRESSURE PLATE



INSTALL PRESSURE PLATE



ENSURE PLATE IS FULLY INSTALLED

860L DOUGH MOULDER

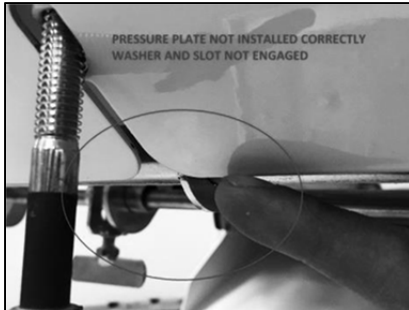

CONNECT WASHER INTO SLOT



INSTALL & ADJUST PRESSURE PLATE

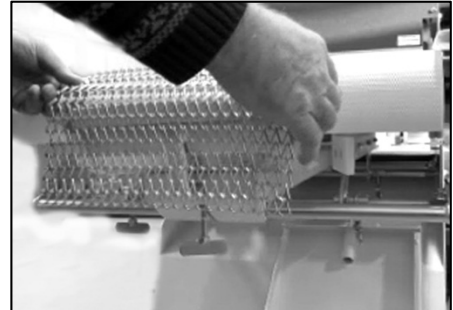

ATTACH CURLING CHAIN WITH SLACK

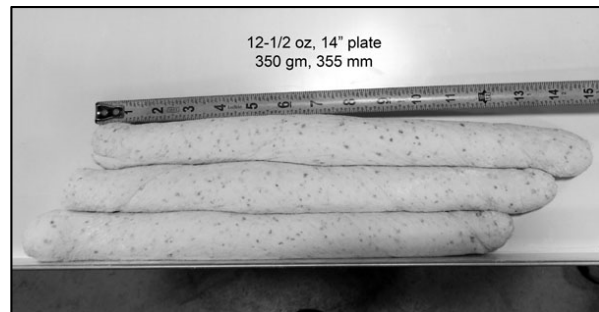
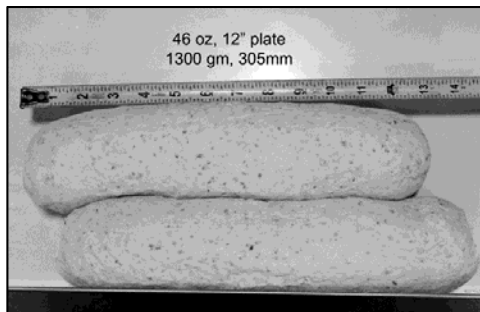
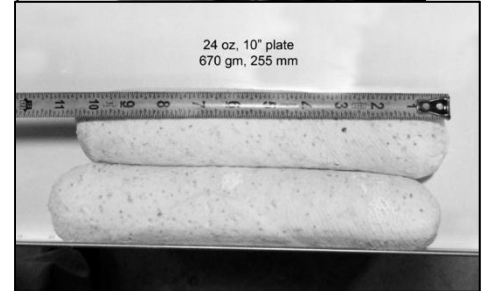
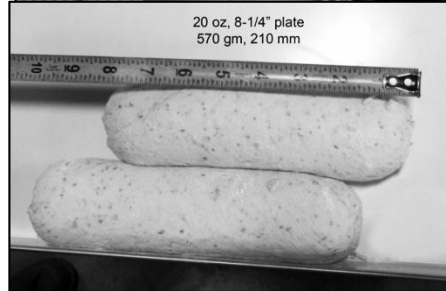
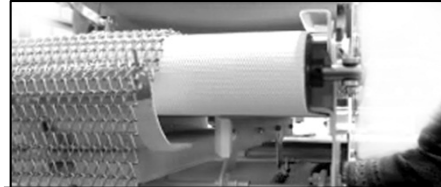
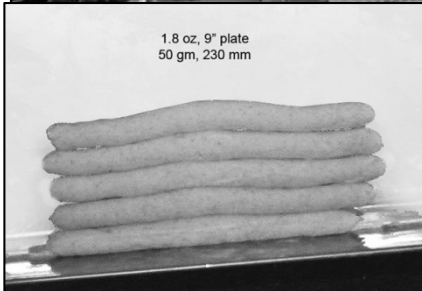

10. INSTRUCTIONS FOR CURVED PRESSURE PLATES

a. **CONCAVE / CONVEX PRESSURE PLATE ADJUSTMENT BOLT (PAB)**

The concave / convex pressure **Plate Adjustment Bolt (PAB)** is located at the back of the pressure plate. This adjustment bolt is designed to fine tune the curvature of the pressure plate, for tapered bread and rolls, or to straighten dough products such as bread sticks or baguettes. Only pressure plates wider than 11" are supplied with the PAB, when ordered.

860L DOUGH MOULDER

The adjustment of this curvature (concave or convex) will depend on the product being moulded. When the desired setting has been found, both nuts on the “PAB” must be tightened onto the bolt support bracket. If different style products are being made, other plates can be supplied.

CAUTION!

**METAL FATIGUE WILL RESULT IF YOU RE-ADJUST THE PLATE FROM CONCAVE TO CONVEX OR VICE VERSA.
THE INTENT OF THIS BOLT IS TO ADJUST THE CURVATURE TO SUIT YOUR SPECIFIC PRODUCT,
BUT NOT TO CHANGE FROM ONE SETTING TO ANOTHER.**

PRESSURE PLATE ADJUSTMENTS

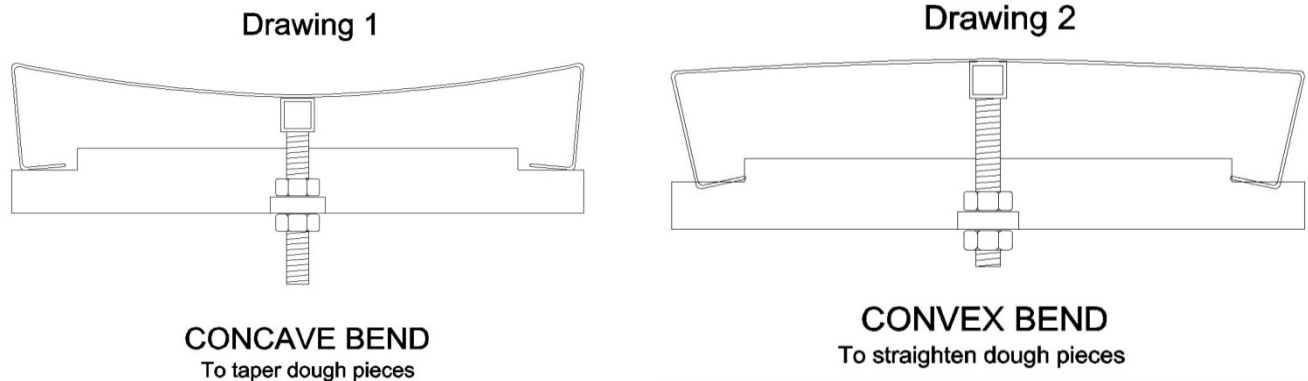

b. PAB ADJUSTMENT PROCEDURES

- i. Determine whether plate is to be concave or convex.
- ii. If the pressure plate is to be concave, loosen inside nut and tighten the top nut to pull the pressure plate towards the bolt support bracket (see drawing 1 - Page 18).
- iii. If the pressure plate is to be convex, loosen the top nut and tighten the bottom nut to push the pressure plate away from the bolt support bracket. (See Drawing 2 - Page 18)
- iv. When the desired setting has been reached for either style, tighten the loose nut to the support bracket.

c. DOUGH CENTERING FOR CURVED PLATES

In order for small dough pieces to be shaped or tapered in a uniform fashion, care must be taken that the throw-in guides are evenly divided from the center. These guides and scaled markings are on the top of the 860L moulder. These guides should be set so that the small dough piece is allowed to feed into the dough rollers without being stalled by these guides. Conversely, these guides must not be open too far since that will allow for un-centered entry of the small dough piece into the dough rollers.

d. PRESSURE PLATE SETTINGS FOR CURVED PLATES

For small dough pieces, the front pressure plate setting (entry end) should be set so the dough piece just carries along between the conveyor belt and pressure plate.

Since all the forming of the tapered dough piece is done at the back (take off end) of the pressure plate, very minor adjustments at this end will make a significant difference in the elongation and shape of the dough piece. Thus, if the dough piece is too short, raise the pressure plate slightly at the back (take off) end only. If the dough piece is too long, then drop the pressure plate at the back end slightly.

860L DOUGH MOULDER

It should also be noted that different mixing times, mixing temperature, formulas and rest time, may require slight variations in the pressure plate settings on a day to day basis.

Since dough consistency changes from Bakery to Bakery, all pressure plate settings are approximate and a guide only. To allow for the time required to choose the most desirable pressure plate settings for the various dough pieces, each pressure plate should be tested in a NON-PRODUCTION environment.

FREQUENTLY ASKED QUESTIONS (FAQ's)

Q: Do I need to pre-round the dough pieces before moulding?

A: No. Scaled pieces from your divider or hand scaled blocks work equally well. Dough pieces that have relaxed after scaling & dividing will make it easier to extend the dough and improve quality. The dough should be one piece, if there are two or more pieces that make the scaled weight, they should be gently folded in before placing it into the hopper. If the pieces are rectangular, then it is important that they are always placed in the dough hopper in a consistent orientation.

Q: Why do I need to change pressure plates?

A: One large plate can form all your products but the shorter dough pieces will be tapered and the ends will be unfinished, the lengths will be inconsistent and a seam will show. The advantage of using the correct plate width will be finished ends, consistent length and a seamless finish. The optional Side Guides are recommended for consistent lengths and seamless finishing.

Many products can be made on one pressure plate. With an 8" wide pressure plate you can produce a 16 oz. rye loaf, an 8" sub bun, hoagie rolls, demi-baguettes or a 3/4 oz. bread stick. All the products will have finished ends and will be consistent in length, thanks to the optional full height side guides. Pressure plates are available from 4" to 9" wide allowing you to make everything from 1/2 oz. rolls to 18 oz. loaves. Curved plates are available to make tapered rolls, dinner rolls, challah stripes and bolillos.

Q: What moulding settings do I use?

A: Moulding settings are where adjustments are made to the infeed hopper, spring loaded roller control system, pressure plate settings and of course the plate sizes. Because there are many combinations and so many types of dough, it is very hard for us to tell you how to set your machine. Testing on a small batch on an off day is best.

Q: How can I tell if the Infeed Guides are set right?

A: Set them to the approximate width of the scaled dough piece. Always keep the Infeed Guides equally spaced from the center. When the dough enters the Pressure Plate, it should not be longer than the width of the plate. If it is too wide, adjust the guides closer together.

Q: How do I know if the Dough Roller Control Panel setting is correct?

A: If the surface of the dough appears torn after passing through the Dough Rollers, reduce the Control Panel spring pressure. Turning the knob clockwise increases the spring pressure on the dough. Higher pressure will give you a tighter crumb structure and a lower number will result in larger holes in your bread. Generally you set the Control Panel to the type and hydration level of your dough rather than the weight.

Q: How can I tell if the Pressure Plate settings are correct?

A: If the finished dough piece appears rough or torn, the Pressure Plate is too close to the Conveyor Belt. If the dough pieces have a large visible seam and unfinished ends, the Pressure Plate should be adjusted closer to the Conveyor Belt. The Pressure Plate should never be set to have the upper (or entry) end closer to the Conveyor Belt than the lower (or exit) end.

TROUBLE SHOOTING

860L DOUGH MOULDER

1. MACHINE DOES NOT START

Cause: *No power*

- Check power supply.
- Check that the stop button is not pressed in.

2. DOUGH TEARING

Cause: *Excessive pressure on dough rollers:*

- Set control panel handle to a smaller number.

3. EXCESSIVE CRUMBS

Cause: *Too much pressure with pressure plate:*

- Increase space between conveyor belt and pressure plate.
- Throw-in guides too far apart or side guides too far from belt. Adjust accordingly.

4. ONE SIDE OF BREAD/ROLLS LARGER

Cause: *Un-centered feeding:*

- Make sure throw-in guides are evenly divided from the center.
- Bread must enter pressure plate dead center.
- The side guides must be equally divided from or against the pressure plate.

5. ROUGH APPEARANCE

Cause: *Pressure plate too close to belt:*

- Increase gap between pressure plate & belt

6. DOUGH STALLS ON DOUGH ROLLER

Cause: *Outer surface of dough too dry and/or excessive flour on dough:*

- Before moulding - Spray surface of dough with water. Do not dust dough balls with flour.
- Increase minimum gap between rollers by adjusting stopper.
- Elongate dough piece before moulding

7. DOUGH PIECES STALLS AT MOUTH OF RETURN PLATE

Cause: *Return plate too close to belt roll.*

- Increase gap between return plate and front belt roller.
- Loosen curling chain on return plate hooks. (3 to 6 links of slack required)

8. LARGE HOLES IN BREAD/ROLLS

Cause: *Surface of dough torn after passing through dough rollers.*

- Surface of dough is torn after passing through dough rollers. Set control panel handle to a smaller number.
- Dough pieces should be completely rolled up before entering return plate. If not, set control panel handle to a smaller number.
- Make sure curling chain is anchored on return plate with 3 to 6 links of slack.
- Dough does not start curling when in contact with curling chain, spray dough lightly with water before moulding.

9. AIR BUBBLES ON OUTER SURFACE AFTER MOULDING

Cause: *Dough piece is not completely curled up before entering return plate.*

- Set control panel to a smaller number.

10. BELT SLIPPING

Cause: *Belt stretched or not adjusted*

- Check belt tension and adjust accordingly.

11. MOTOR STOPS

Cause: *Overloaded*

- Excessive dough buildup on belt. Clean belt with plastic scraper.
- Side guides too close to belt, re-adjust.
- Too many dough pieces being worked by machine at one time.
- Inspect safety bar for proper operation

12. SCRAPER NOISE

Cause: *Worn or damaged scrapers*

- Check for proper installation of scraper assemblies (See Page 8 Preventative Maintenance Daily Section).
- Replace worn scraper blades.

13. ROLLER CHAIN NOISE

Cause: *Roller chain rubbing together by chain tightener, roller chain is dry*

- See "Preventative Maintenance Schedule". (Page 8 - Monthly & Bi-Monthly Section)

CLEANING & PREVENTATIVE MAINTENANCE SCHEDULE



WARNING, MAKE SURE TO ALWAYS DISCONNECT THE EQUIPMENT FROM THE POWER SUPPLY BEFORE PERFORMING ANY SERVICING, MAINTENANCE, AND CLEANING!

DAILY

1. SAFETY BAR INTER-LOCK SWITCH

The safety bar is located on top of the throw in guides and is connected to an interlock switch. Prior to daily use, check proper operation of the safety bar by starting the unit and then stopping the machine by pushing down on the safety bar. Adjust or replace micro switch if the machine does not stop. The safety bar should never be removed or restricted of motion in any manner.

Do not use the machine if the inter-lock switch is defective.

2. CONVEYOR BELT CLEANING

Clean belt daily with a plastic scraper - ***Do not use a steel scraper!***

3. REMOVE AND CLEAN SCRAPER ASSEMBLY

The scrapers should be removed for cleaning on a daily basis. To remove the scrapers, unhook the scraper spring wire handle from the holding mechanism and lift up out of the half-moon holder. Pull scraper forward past the half-moon holder, then drop down towards belt, thereby releasing opposite end from frame support. To re-install scraper into machine or onto the adjustable dough roller, insert non-handle side into frame support, position spring wire handle into half-moon holder, then lock spring wire handle into position. ***Do not use any sharp object to clean the scraper blade or immerse scraper assembly into water!***

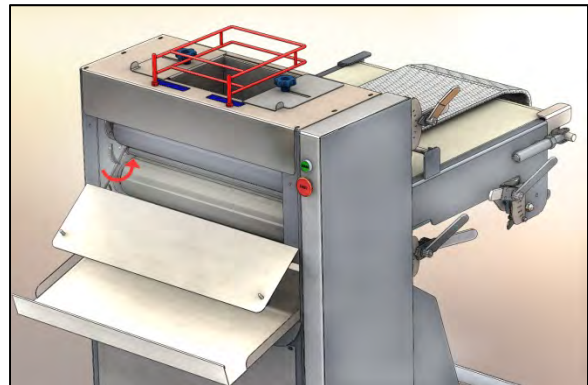
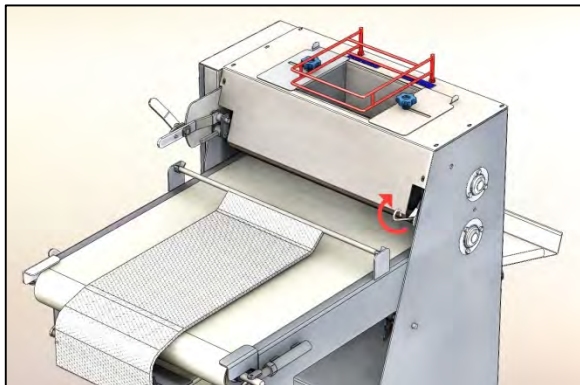

860L DOUGH MOULDER

4. REMOVE AND CLEAN PRESSURE PLATES

Do not use any cleaning solutions or sharp objects to clean the fabric. Do not immerse pressure plate in water. Use a plastic scraper for cleaning. Wipe clean with dry cloth. You can also rub flour into the fabric to help remove remaining dough and moisture.

5. CLEANING MACHINE

Use a brush, air hose or damp rag. **Do not spray machine down with water!**

6. CONVEYOR BELT TRACKING

Check conveyor belt tracking. The conveyor belt should not rub against the belt guides underneath the machine. If the belt should run to one side, tighten nut on the belt roll holder on the side to which it is running a ½ turn and loosen the opposite end a ½ turn. Should belt slip occur, tighten both nuts ½ turn.

Do not over tighten the conveyor belt.

EVERY MONTH

1. OIL ROLLER CHAIN

For best result use summer type chain saw bar oil, a few drops each month will keep chain lubricated.

- Inspect roller chain and lubricate. Do not use grease on the roller chain. A dry roller chain will cause premature sprocket wear.

EVERY TWO MONTHS

1. CHAIN TIGHTENER

Grease 2 idler sprocket Pull back on chain tightener assembly and release. Chain tightener should “spring back”. If not, remove assembly from pivot pin and lubricate with anti-seize compound or grease.

2. PRESSURE PLATE CLAMPING BOLTS

Lubricate clamping bolt or bolts on pressure plate system with anti-seize compound or grease.

ONCE PER YEAR

1. GEAR MOTOR

Inspect oil level in gear motor. To access gear motor, remove lower back panel, remove filler cap on speed reducer, insert wire into reducer, oil should be present 5 inches from top of reducer. Add CLP 220 miner gear oil if required. **Do not over fill.** Oil will come out of breather hole on filler cap if too much oil is put into reducer.

PRESSURE PLATES

Additional pressure plates can be ordered to suit your changing needs. If unsure of which pressure plate will best suit your needs to achieve a high quality product, please contact us either by phone at 1 800-253-3893

Flat pressure plates: Pressure plate curvature adjustment on plates 12” and wider
860L 3½”, 4¼”, 5¼”, 6½”, 8”, 9¼”, 10½”, 12”, 14”, 16”, 18” and 20” x 35” long
 Custom sizes or curved pressure plates are available for tapered products
 Contact your dealer or Bloemhof Inc.

ELECTRICAL SPECIFICATIONS

MOTOR RATINGS FOR 860 / 860L MOULDER					
Model	Horsepower	Volts	Amps	Hertz	Phase
860L	3/4	115	4.1	60	1
860L	3/4	230	2.1	60	1
860L	3/4	208/230	1.9	60	3
860L	3/4	460	.45	50	3

PARTS LIST

When ordering parts please make sure to have the following information available:

- **Model**
- **Serial Number** (Side panel of the machine, found on the name plate)
- **Part Number and Quantity** (If unsure please contact our Parts Person for help)

PARTS CONTACT

**Contact your local bakery equipment service company
 or**

OLIVER 3236 Wilson Dr. Walker ,Mi., 49534
 Tel 1-800-253-3893 option 2, Fax 616-456-7791

0	TOOL NAME	NUMBER
---	-----------	--------

CHANGE
C 0860-0064

ITEM	PART NUMBER	DESCRIPTION	QUAN.
------	-------------	-------------	-------

Item Number	Part Number	Description	Qty
1	0860-0009	WELDMENT-FORK	2
2	0860-0011	COMMON IDLE ROLLER SHAFT	1
3	0860-0048	24" IDLER BELT ROLLER	1
4	5251-3948	NTN ASS204-012N 3/4" BEARING W/ LOCKING SET	2
5	5832-0527	NUT - HEX FULL 3/4-10NC FIN STST	2
6	5832-0590	NUT-ACORN 1/4-20	2
7	5843-1007	SCREW- HEX HD 1/4-20 X 1-1/2 STST	2

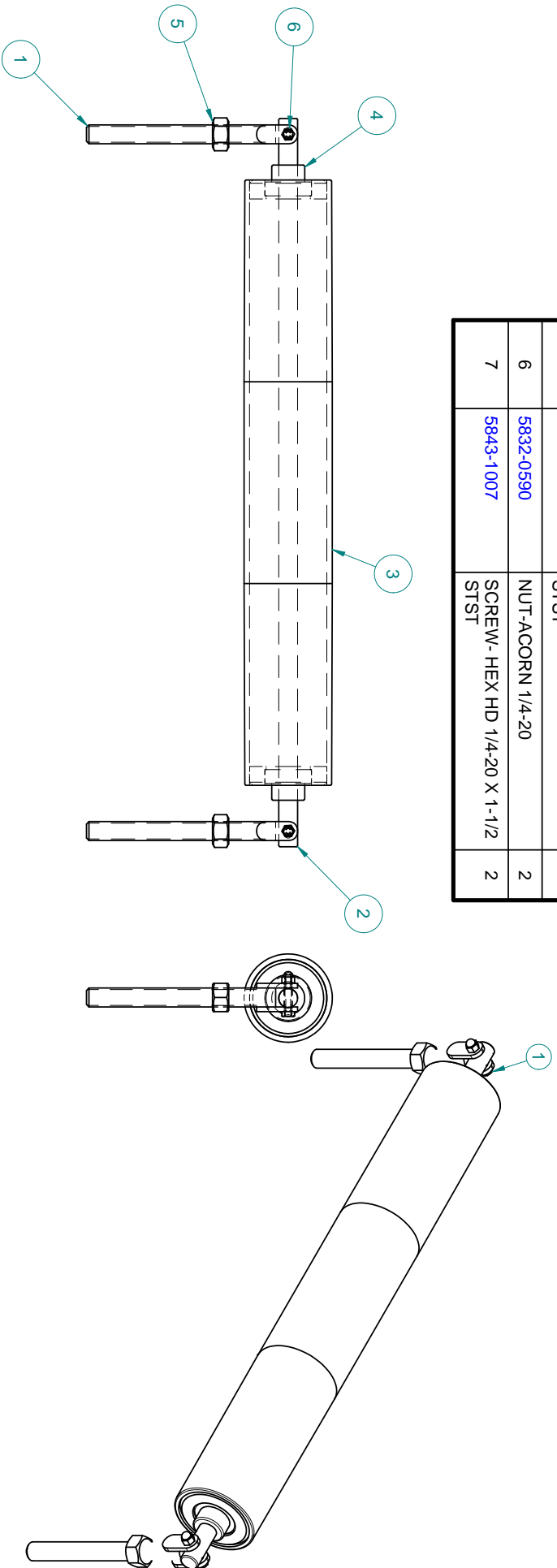

LTR	CHANGE	DATE	BY	EC NO.	LTR	CHANGE	DATE	BY	EC NO.



WALKER, MICHIGAN, U.S.A. 49534-7564
 THIS DRAWING AND ALL PROPRIETARY RIGHTS AND CONCEPTS HEREIN ARE THE EXCLUSIVE PROPERTY OF OLIVER PACKAGING AND EQUIPMENT COMPANY AND ARE NOT TO BE REPRODUCED OR TRANSMITTED IN ANY FORM OR BY ANY MEANS, ELECTRONIC OR MECHANICAL, INCLUDING PHOTOCOPYING, RECORDING, OR BY ANY INFORMATION STORAGE AND RETRIEVAL SYSTEM, WITHOUT THE WRITTEN PERMISSION OF OLIVER PACKAGING & EQUIPMENT COMPANY.

NAME **24in X 3.5in IDLE ROLLER COMPLETE ASSEMBLY**
 MATL. **SEE CHART**
 DRAWN BY **WHW** DATE **3-2-16** FINISH _____ SCALE **1:4**
 REMOVE BURRS & SHARP EDGES. DO NOT SCALE THIS DRAWING. DIMENSIONAL TOLERANCES UNLESS SPECIFIED FRACTIONAL ±.164 DECIMAL ±.005/ANGULAR ±1°

0	TOOL NAME	NUMBER
---	-----------	--------

CHANGE
C 0860-0066

ITEM	PART NUMBER	DESCRIPTION	QUAN.
------	-------------	-------------	-------

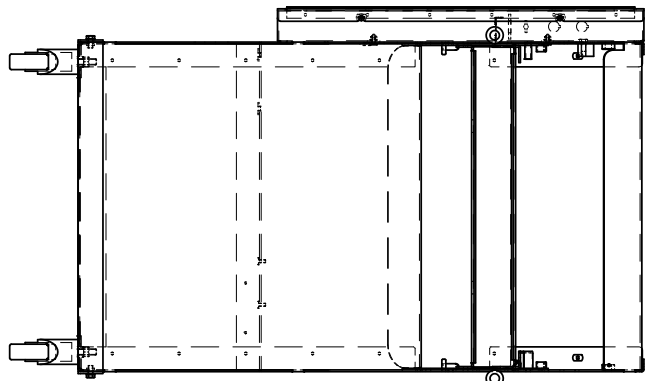
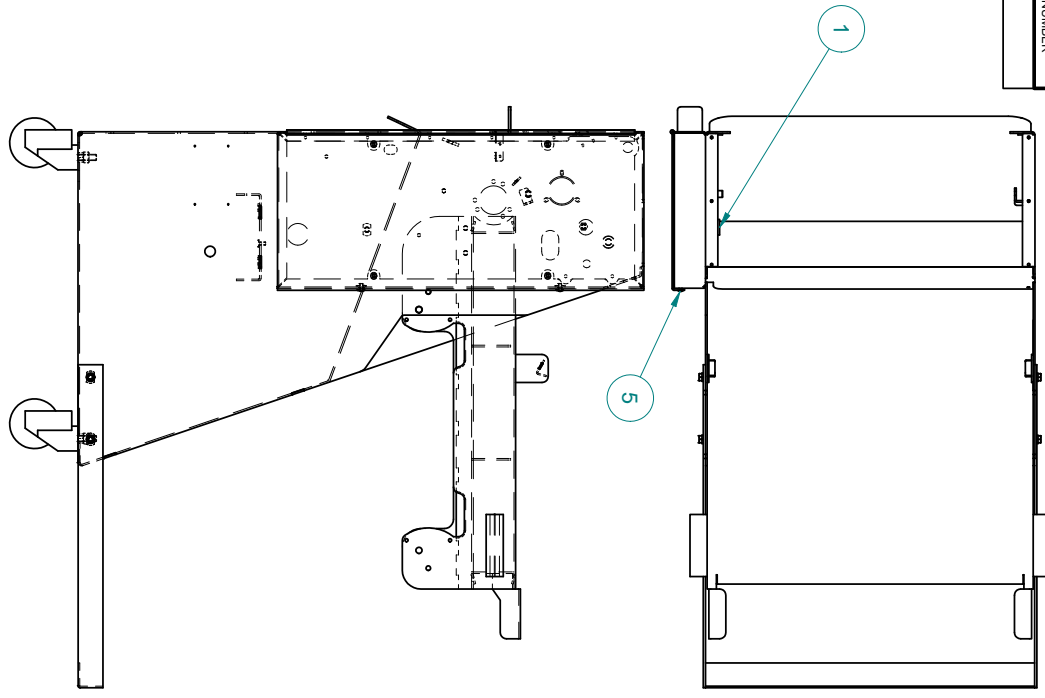

LTR	CHANGE	DATE	BY	EC NO.	LTR	CHANGE	DATE	BY	EC NO.

WALKER, MICHIGAN, U.S.A. 49534-7564



THIS DRAWING AND ALL PROPRIETARY RIGHTS AND CONCEPTS HEREIN ARE THE EXCLUSIVE PROPERTY OF OLIVER PACKAGING AND EQUIPMENT COMPANY AND ARE NOT TO BE REPRODUCED OR TRANSMITTED IN ANY FORM OR BY ANY MEANS, SUCH AS RIGHTS WITHOUT PERMISSION OF OLIVER PACKAGING & EQUIPMENT COMPANY.

NAME **FRAME ASSEMBLY**

MATL NO. **SEE CHART**

DRAWN BY **BW** DATE **6-16-16** FINISH _____ SCALE **1:10**

REMOVE BARRS & SHARP EDGES
DIMENSIONAL TOLERANCES UNLESS SPECIFIED FRACTIONAL ±.164 DECIMAL ±.005/ANGULAR ±1°

DO NOT SCALE THIS DRAWING

0	TOOL NAME	NUMBER
---	-----------	--------

CHANGE

C 0860-0066

ITEM	PART NUMBER	DESCRIPTION	QUAN.
------	-------------	-------------	-------

Item Number	Part Number	Description	Qty
1	0860-0063	STOP-ROLLER	1
2	5832-0524	NUT - HEX FULL 1/2-13NC FIN STST	4
3	5832-0590	NUT-ACORN 1/4-20	4
4	5843-1052	SCREW - HEX HD 3/8-16 X 3/4 STST	5
5	5843-5412	SCREW-TRUSS HD SLTD 1/4-20 X 1/2	2
6	5851-9357	WASHER- LOCK 1/4 STST SPRING	4
7	5851-9359	WASHER-3/8" HELICAL SPRING LOCK STST	4
8	5902-2409	CASTER-STEM, 4" WHEEL 150LBS	4
9	860-0001	BRACKET-PRESSURE PLATE STORAGE	1
10	860-0020	SPROCKET BOX WELDMENT	1
11	860-0062	860L FRAME WELDMENT	1

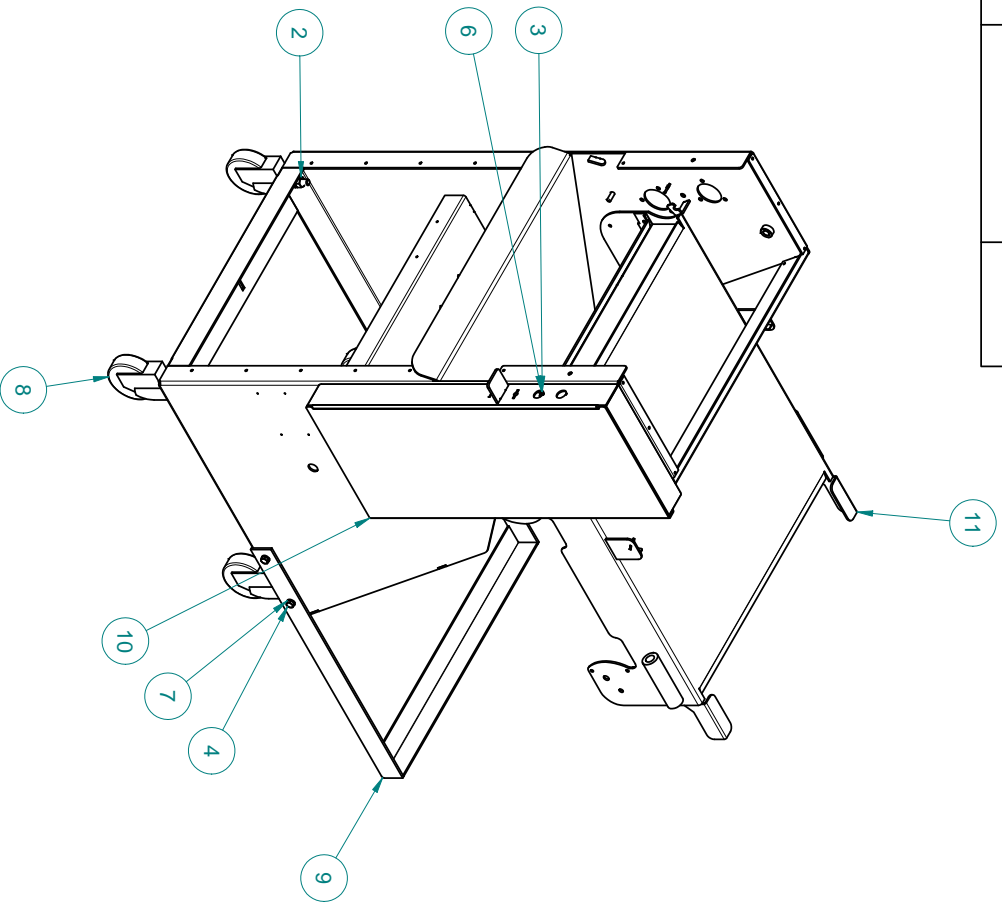

LTR	CHANGE	DATE	BY	EC NO.	LTR	CHANGE	DATE	BY	EC NO.

 WALKER, MICHIGAN, U.S.A. 49534-7564

THIS DRAWING AND ALL PROPRIETARY RIGHTS AND CONCEPTS HEREIN ARE THE EXCLUSIVE PROPERTY OF OLIVER PACKAGING AND EQUIPMENT COMPANY AND ARE NOT TO BE REPRODUCED OR TRANSMITTED IN ANY FORM OR BY ANY MEANS, SUCH AS RIGHTS WITHOUT PERMISSION OF OLIVER PACKAGING & EQUIPMENT COMPANY.

NAME: **FRAME ASSEMBLY**
 MATL: _____
 MATL NO.: _____ FINISH: _____
 DRAWN BY: _____ DATE: _____ SCALE: _____
 REMOVE SHARP EDGES
 DIMENSIONAL TOLERANCES UNLESS SPECIFIED FRACTIONAL ± .164 DECIMAL ± .005/ANGULAR ± 1°

DO NOT SCALE THIS DRAWING

C 0860-0067

0	TOOL NAME	NUMBER
---	-----------	--------

ITEM	PART NUMBER	DESCRIPTION	QUAN.
------	-------------	-------------	-------

Item Number	Part Number	Description	Qty
1	0860-0010	WELDMENT-ROLLER ACCESS	1
2	0860-0013	TRAY-CATCH	1
3	0860-0074	GUARD, SWITCHES	1
4	5843-1231	SCREW-HEX HD #10-24 X 3/8, STST	2
5	5843-5412	SCREW-TRUSS HD SLTD 1/4-20 X 1/2	12
6	5851-9395	WASHER-INT TOOTH 1/4	12
7	5911-7125	KNOB-2 PRONG, W/1/4-20X1 STUD	2
8	5918-2743	RETAINER PUSH ON 1/4-20	2
9	860-0014-1	MOTOR ACCESS PANEL	1

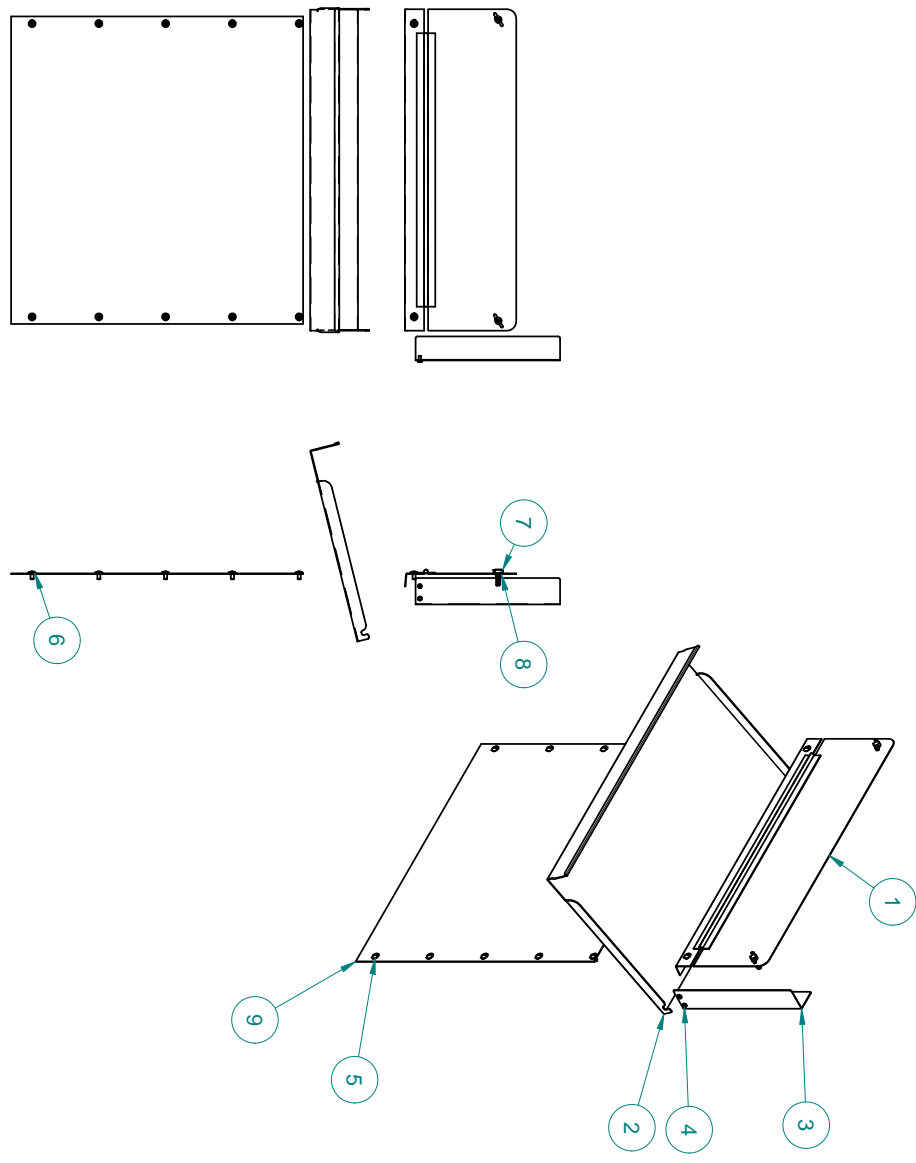

LTR	CHANGE	DATE	BY	EC NO.	LTR	CHANGE	DATE	BY	EC NO.	<p>WALKER, MICHIGAN, U.S.A. 49534-7564</p> <p>THIS DRAWING AND ALL PROPRIETARY RIGHTS AND CONCEPTS HEREIN ARE THE EXCLUSIVE PROPERTY OF OLIVER PACKAGING AND EQUIPMENT COMPANY AND ARE NOT TO BE REPRODUCED OR TRANSMITTED IN ANY FORM OR BY ANY MEANS, SUCH AS RIGHTS WITHOUT PERMISSION OF OLIVER PACKAGING & EQUIPMENT COMPANY.</p>	<p>NAME: COVERS ASSEMBLY</p> <p>DRAWN BY: BW DATE: 6-16-16 FINISH: _____ SCALE: 1:10</p> <p>REMOVE BARRS & SHARP EDGES DIMENSIONAL TOLERANCES UNLESS SPECIFIED FRACTIONAL ± .164 DECIMAL ± .005 ANGULAR ± 1°</p>

ADDED BALLONS 7&8 AND BALLON 9 WAS 8-10-16
 860-0014 CHANGE BY BW 19632

0	TOOL NAME	NUMBER
---	-----------	--------

CHANGE
C 0860-0088

ITEM	PART NUMBER	DESCRIPTION	QUANT.
------	-------------	-------------	--------

Item Number	Part Number	Description	Qty
1	0860-0090	SCRAPER BLADE HOLDER	1
2	0860-0091	SCRAPER PIN SOLID	1
3	0860-0092	SCRAPER HOOK	1
4	0860-0093	SCRAPER PIN-SLOTTED	1
5	5500-2950	BLADE-SCRAPER 860L	1
6	5835-6784	PIN - SPRING 1/8 X 5/8" STST	3

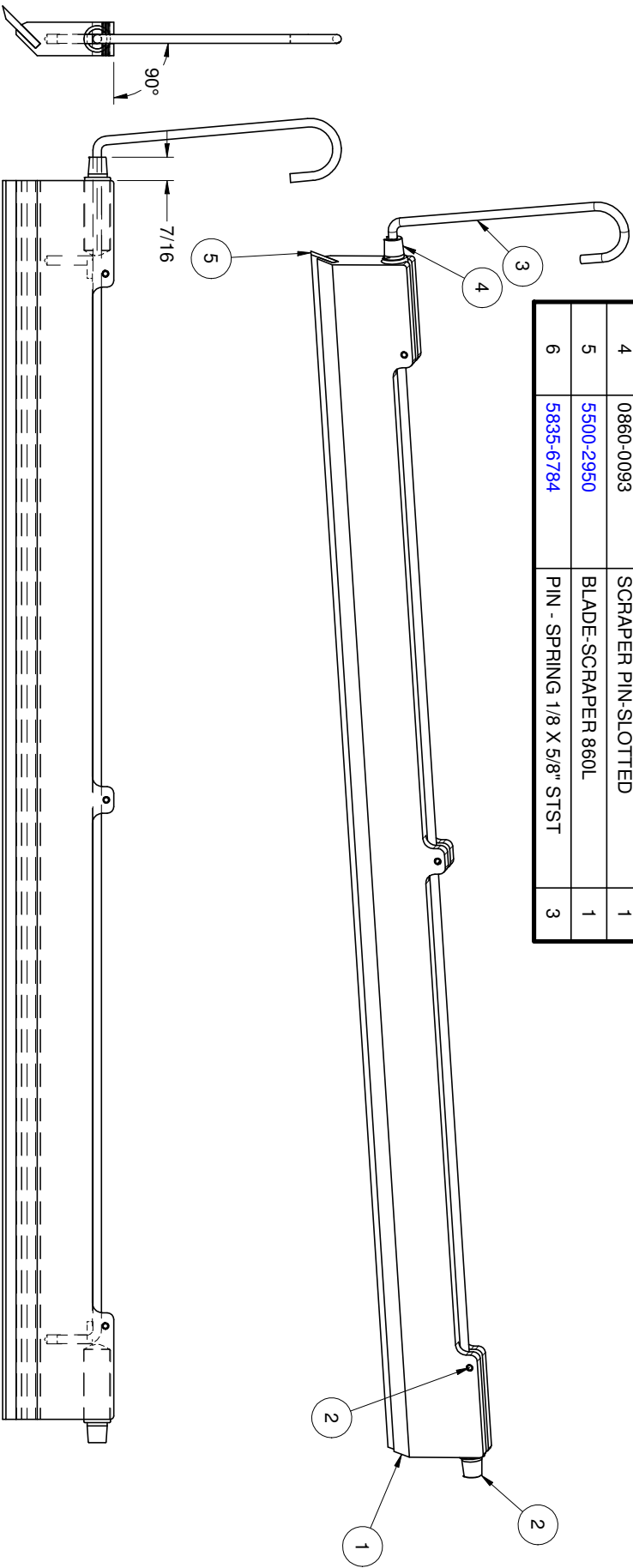

				WALKER, MICHIGAN, U.S.A. 49834-7564 THE DRAWING AND ALL PROPRIETARY RIGHTS AND CONCEPTS HEREIN ARE THE EXCLUSIVE PROPERTY OF OLIVER PACKAGING AND EQUIPMENT COMPANY AND ARE NOT TO BE REPRODUCED OR TRANSMITTED IN ANY FORM OR BY ANY MEANS, ELECTRONIC OR MECHANICAL, INCLUDING PHOTOCOPYING, RECORDING, OR BY ANY INFORMATION STORAGE AND RETRIEVAL SYSTEM, WITHOUT PERMISSION OF OLIVER PACKAGING & EQUIPMENT COMPANY.					
NAME SCRAPER BLADE ASSEMBLY REAR				DRAWN BY WHW DATE 1-4-17 SCALE 1/4					
MATL. SEE LIST				REMOVE BURRS & SHARP EDGES DIMENSIONAL TOLERANCES UNLESS SPECIFIED FRACTIONAL ±.164 DECIMAL ±.005/ANGULAR ±1°					
MATL. NO. _____ FINISH _____				DO NOT SCALE THIS DRAWING					
LTR	CHANGE	DATE	BY	EC. NO.	LTR	CHANGE	DATE	BY	EC. NO.

C 0860-0069

0	TOOL NAME	NUMBER
---	-----------	--------

ITEM	PART NUMBER	DESCRIPTION	QUAN.
------	-------------	-------------	-------

Item Number	Part Number	Description	Qty
1	0860-0002	FIXED DOUGH ROLLER ASSY	1
2	0860-0070	BEARING 3/4 W/COVER	1
3	0860-1197	BEARING ASSY .875	1
4	5616-9085	SPROCKET 40B16 W/.875 BORE & 3/16 KEY	1
5	5824-2319	KEY 3/16" SQ X 1" LG STST	1

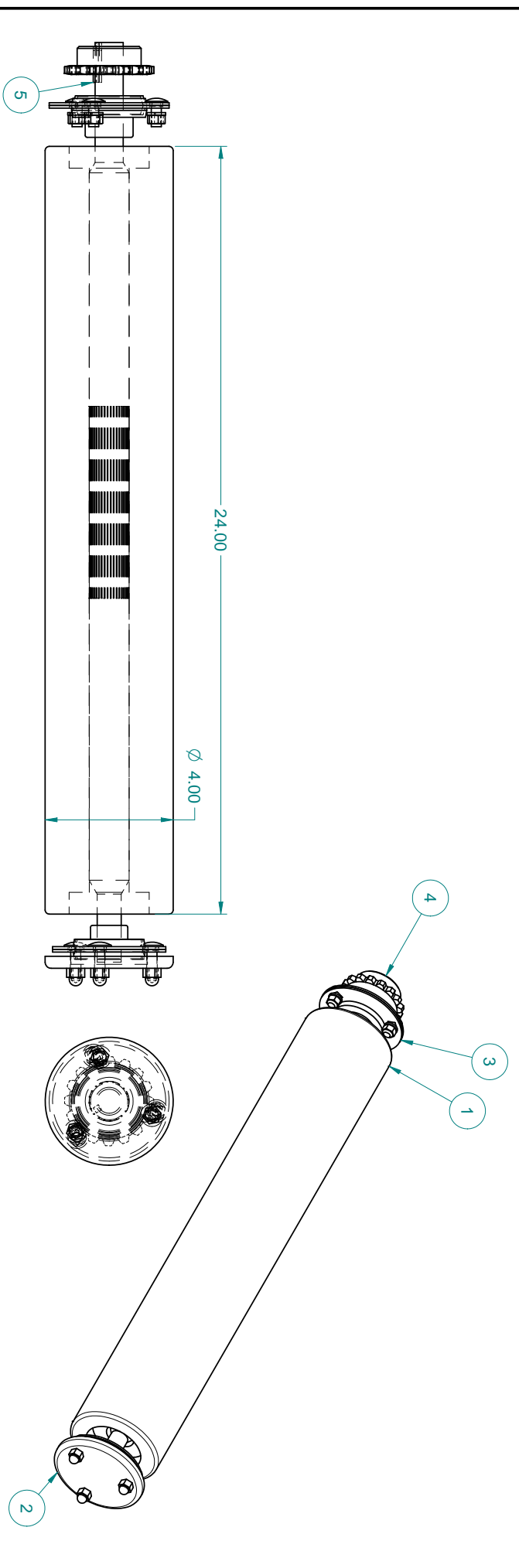

LTR	CHANGE	DATE	BY	EC NO.	LTR	CHANGE	DATE	BY	EC NO.
-----	--------	------	----	--------	-----	--------	------	----	--------

OLIVER

WALKER, MICHIGAN, U.S.A. 49534-7564

THIS DRAWING AND ALL PROPRIETARY RIGHTS AND CONCEPTS HEREIN ARE THE EXCLUSIVE PROPERTY OF OLIVER PACKAGING AND EQUIPMENT COMPANY AND ARE NOT TO BE REPRODUCED OR TRANSMITTED IN ANY FORM OR BY ANY MEANS, SUCH AS RIGHTS WITHOUT PERMISSION OF OLIVER PACKAGING & EQUIPMENT COMPANY.

NAME: **FIXED DOUGH ROLLER ASSY COMPLETE**

MATL. NO. _____ FINISH _____ SCALE: **1.4**

DRAWN BY: **WHW** DATE: **3-3-16**

REMOVE SHARP EDGES UNLESS SPECIFIED FRACTIONAL. * 1/64" DECIMAL. * .005" ANGULAR * 1"

DO NOT SCALE THIS DRAWING DIMENSIONAL TOLERANCES UNLESS SPECIFIED FRACTIONAL.

0	TOOL NAME	NUMBER
---	-----------	--------

CHANGE	ITEM	PART NUMBER	DESCRIPTION	QUAN.
--------	------	-------------	-------------	-------

C 0860-0071

Item Number	Part Number	Description	Qty
1	0860-0049	24in x 3.5in DRIVE ROLLER ASSY	1
2	0860-0072	BEARING ASSY OUTSIDE .875	1
3	0860-1197	BEARING ASSY .875	1
4	5616-9085	SPROCKET 40B16 W/.875 BORE & 3/16 KEY	1
5	5824-2319	KEY 3/16" SQ X 1" LG STST	1

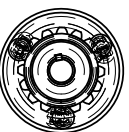
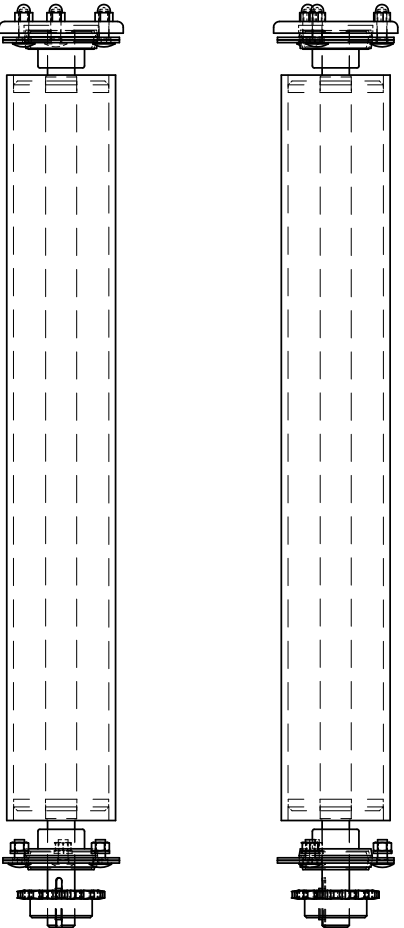
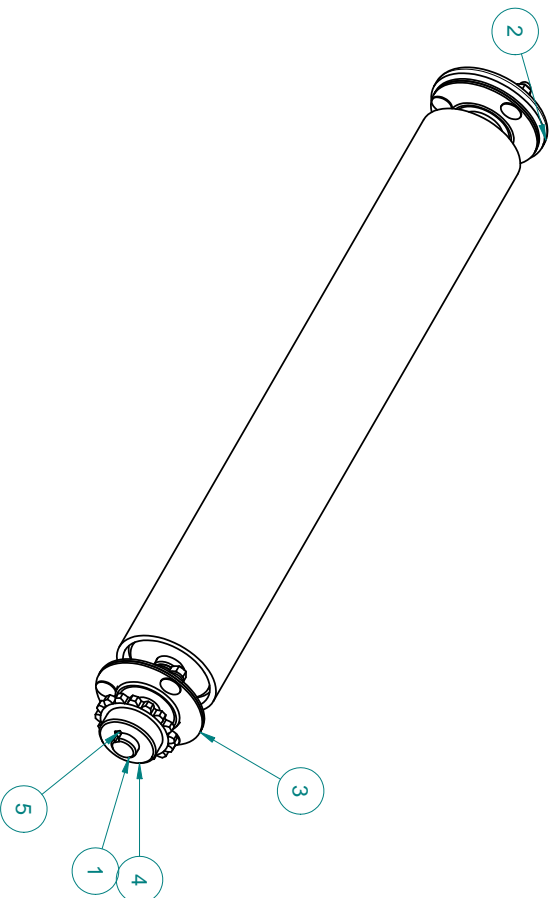

LTR	CHANGE	DATE	BY	EC NO.	LTR	CHANGE	DATE	BY	EC NO.

WALKER, MICHIGAN, U.S.A. 49534-7564



THIS DRAWING AND ALL PROPRIETARY RIGHTS AND CONCEPTS HEREIN ARE THE EXCLUSIVE PROPERTY OF OLIVER PACKAGING AND EQUIPMENT COMPANY AND ARE NOT TO BE REPRODUCED OR TRANSMITTED IN ANY FORM OR BY ANY MEANS, ELECTRONIC OR MECHANICAL, INCLUDING PHOTOCOPYING, RECORDING, OR BY ANY INFORMATION STORAGE AND RETRIEVAL SYSTEM, WITHOUT PERMISSION OF OLIVER PACKAGING & EQUIPMENT COMPANY.

NAME: **24in X 3.5in BACK BELT ROLLER COMPLETE**

MATL: **SEE CHART**

DRAWN BY: **WHW** DATE: **3-3-16** FINISH: _____ SCALE: **1:4**

REMOVE BARRS & SHARP EDGES. DO NOT SCALE THIS DRAWING DIMENSIONAL TOLERANCES UNLESS SPECIFIED FRACTIONAL ±.164 DECIMAL ±.005 ANGULAR ±1°

0	TOOL NAME	NUMBER
---	-----------	--------

CHANGE
C 0860-0073

ITEM	PART NUMBER	DESCRIPTION	QUAN.
------	-------------	-------------	-------

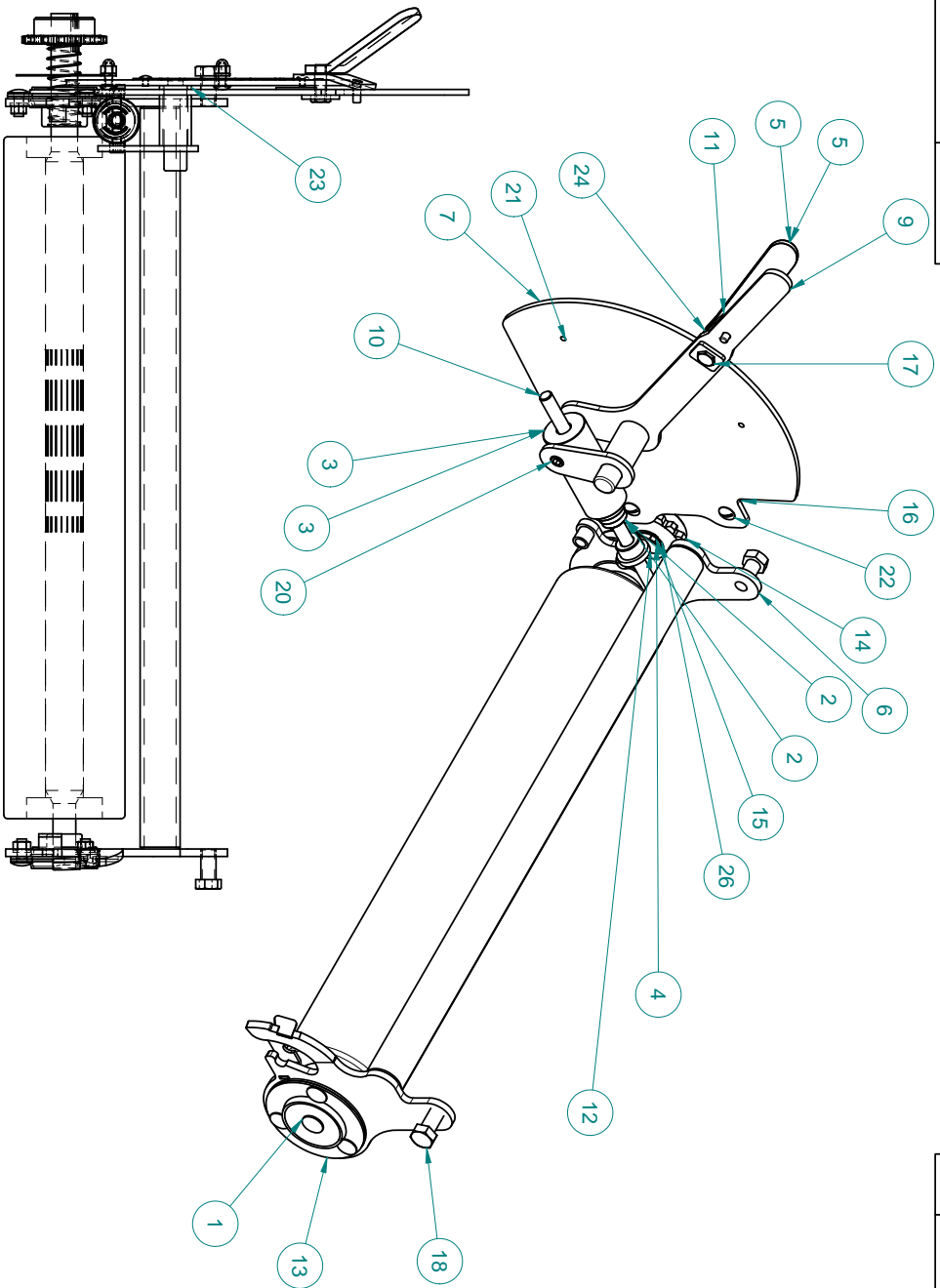

DETAIL A

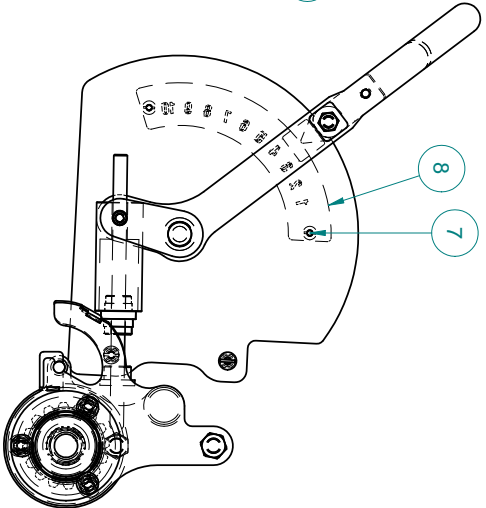
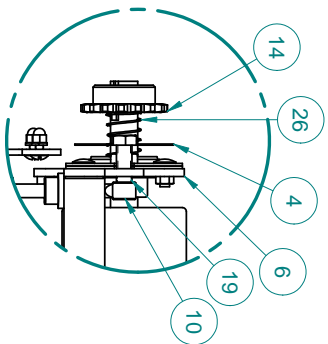

LTR	CHANGE	DATE	BY	EC NO.	LTR	CHANGE	DATE	BY	EC NO.



WALKER, MICHIGAN, U.S.A. 49534-7564

THIS DRAWING AND ALL PROPRIETARY RIGHTS AND CONCEPTS HEREIN ARE THE EXCLUSIVE PROPERTY OF OLIVER PACKAGING AND EQUIPMENT COMPANY AND ARE NOT TO BE REPRODUCED OR TRANSMITTED IN ANY FORM OR BY ANY MEANS, SUCH AS RIGHTS WITHOUT PERMISSION OF OLIVER PACKAGING & EQUIPMENT COMPANY.

NAME **ROLL HOLDER ASSY**

MATL. **SEE CHART**

MATL. NO. _____ FINISH _____

DRAWN BY **WHW** DATE **3-4-16** SCALE **1:4**

REMOVE BURRS & SHARP EDGES. DO NOT SCALE THIS DRAWING DIMENSIONAL TOLERANCES UNLESS SPECIFIED FRACTIONAL, ±.164 DECIMAL, ±.003 ANGULAR ±1°

C 0860-0073

0	TOOL NAME	NUMBER	ITEM	PART NUMBER	DESCRIPTION	QUAN.
---	-----------	--------	------	-------------	-------------	-------

Item Number	Part Number	Description	Qty	Item Number	Part Number	Description	Qty
1	0860-0003	ADJUSTABLE DOUGH ROLLER ASSEMBLY	1	18	5843-1102	SCREW- HEX HD 1/2-13 X 1 STST	2
2	0860-0015	DOUBLE SPRING HOLDER	2	19	5843-1352	SCREW- HEX HD 1/2-20 X 1 STST	1
3	0860-0016	SPRING PIVOT TUBE	1	20	5843-1551	SCREW- STST SOCKET HD 5/16-18 X 1/2	2
4	0860-0019	GUARD-SPLASH	1	21	5843-5383	SCREW-TRUSS HEAD 10-24 X 1/4 STST	2
5	0860-0043	CLAMPING HANDLE	2	22	5843-5414	SCREW-TRUSS HD SLTD 1/4-20 X 3/4	2
6	0860-0050	25in ADJ DOUGH ROLL HOLDER FRAME	1	23	5851-8213	WASHER-13/16 X 1.057 FLAT NYLON	1
7	0860-0052	INDEX PLATE WELDMENT	1	24	5851-9306	WASHER - FLAT 3/8" 18-8 STST	1
8	0860-0053	CONTROL PLATE DIAL	1	25*	5851-9357	WASHER- LOCK 1/4 STST SPRING	2
9	0860-0054	ROLLER INDEX HANDLE WELDMENT	1	26	7015-4202	SPRING-COMP 1.0950D X .045WD X 2.75L	1
10	0860-0055	9" ADJ ROLLER PUSH ROD WELD	1				
11	0860-0056	CONTROL PANEL CLAMP WELDMENT	1				
12	0860-1190	BEARING ASSY .875in WITH NOTCHED FLANGES	1				
13	0860-1196	BEARING ASSY .750in	1				
14	5616-9085	SPROCKET 40B16 W/.875 BORE & 3/16 KEY	1				
15	5824-2319	KEY 3/16" SQ X 1" LG STST	1				
16	5832-0590	NUT-ACORN 1/4-20	2				
17	5843-1054	SCREW- HEX HD 3/8-16 X 1" STST	1				

LTR	CHANGE	DATE	BY	EC NO.	LTR	CHANGE	DATE	BY	EC NO.



WALKER, MICHIGAN, U.S.A. 49534-7564

THIS DRAWING AND ALL PROPRIETARY RIGHTS AND CONCEPTS HEREIN ARE THE EXCLUSIVE PROPERTY OF OLIVER PACKAGING AND EQUIPMENT COMPANY AND ARE NOT TO BE REPRODUCED OR TRANSMITTED IN ANY FORM OR BY ANY MEANS, ELECTRONIC OR MECHANICAL, INCLUDING PHOTOCOPYING, RECORDING, OR BY ANY INFORMATION STORAGE AND RETRIEVAL SYSTEM, WITHOUT PERMISSION OF OLIVER PACKAGING & EQUIPMENT COMPANY.

NAME: **ROLL HOLDER ASSY**

MATL NO. _____ DATE _____ FINISH _____ SCALE _____

DRAWN BY _____

REMOVE BURRS & SHARP EDGES. DO NOT SCALE THIS DRAWING UNLESS SPECIFIED. FRACTIONAL: +.164, DECIMAL: +.005, ANGULAR: ±1°

0	TOOL NAME	NUMBER
---	-----------	--------

CHANGE
C 0860-1062

ITEM	PART NUMBER	DESCRIPTION	QUAN.
------	-------------	-------------	-------

Item Number	Part Number	Description	Qty
1	0860-0006	WELDMENT-SAFETY BAR	1
2	0860-0012-0001	GUIDE-RH DOUGH	1
3	0860-0012-0002	GUIDE-LH DOUGH	1
4	0860-0040	COVER WELDMENT	1
5	5835-6442	7/64 X 1 STST COTTER PIN	2
6	5843-5412	SCREW-TRUSS HD SLTD 1/4-20 X 1/2	7
7	5851-9306	WASHER - FLAT 3/8" 18-8 STST	2
8	5911-7027	KNOB-KNRLD 1-7/8"DIA, 3/8-16 STUD	2
9	7023-4100	SPRING-EXT .5 OD X .055 X 2.25 FL	1
10	8832-0011	NUT-HEX HD STST M4 DIN 934	2
11	8843-2277	SCREW-STST SLOTTED PAN HD M4 X 30MM	2
12	8851-9861	WASHER-STST INT TOOTH M4	2

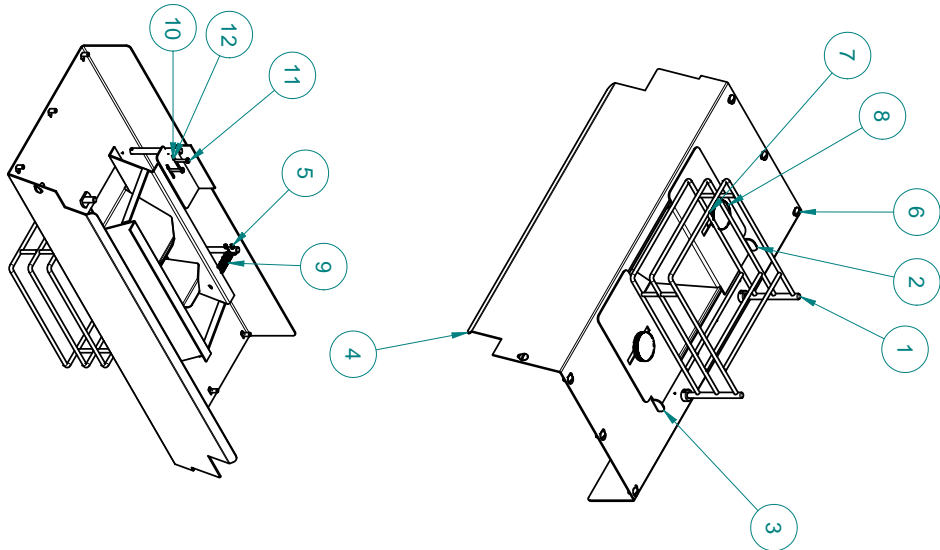
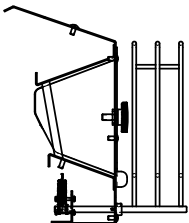
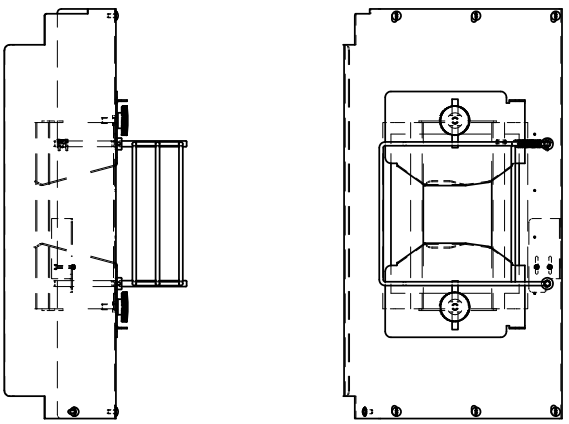

LTR	CHANGE	DATE	BY	EC NO.	LTR	CHANGE	DATE	BY	EC NO.



WALKER, MICHIGAN, U.S.A. 49534-7564
 THE DRAWING AND ALL PROPRIETARY RIGHTS AND CONCEPTS HEREIN ARE THE EXCLUSIVE PROPERTY OF OLIVER PACKAGING AND EQUIPMENT COMPANY AND ARE NOT TO BE REPRODUCED OR TRANSMITTED IN ANY FORM OR BY ANY MEANS, WITHOUT PERMISSION OF OLIVER PACKAGING & EQUIPMENT COMPANY.

NAME **INFEED ASSEMBLY**
 MATL NO. **SEE CHART**
 DRAWN BY **BW** DATE **6-15-16** FINISH _____ SCALE **1:8**
 REMOVE BURRS & SHARP EDGES
 DIMENSIONAL TOLERANCES UNLESS SPECIFIED FRACTIONAL ±.164 DECIMAL ±.005/ANGULAR ±1

0	TOOL NAME	NUMBER
---	-----------	--------

CHANGE
C 0860-1251

ITEM	PART NUMBER	DESCRIPTION	QUAN.
------	-------------	-------------	-------

Item Number	Part Number	Description	Qty
1	0860-0046	MODIFIED SPROCKET	1
2	5251-3947	BEARING-AEL202 W/ .625 BORE AND COLLAR	1
3	5832-0507	NUT - HEX JAM 3/4-10NC FIN STST	1
4	5832-0526	NUT-HEX FULL 5/8-11NC STST FIN	1
5	5843-1131	SCREW- HEX HD 5/8-11 X 2-1/2" STST	1
6	5851-9362	WASHER-STST 5/8" SPRING LOCK	1

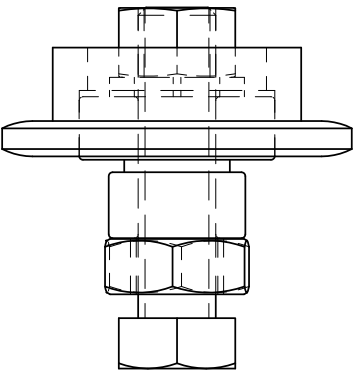
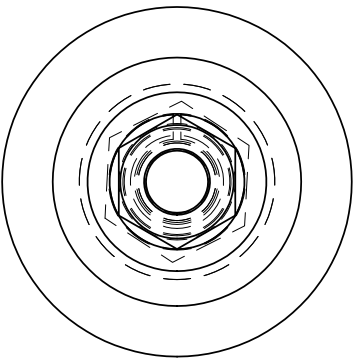
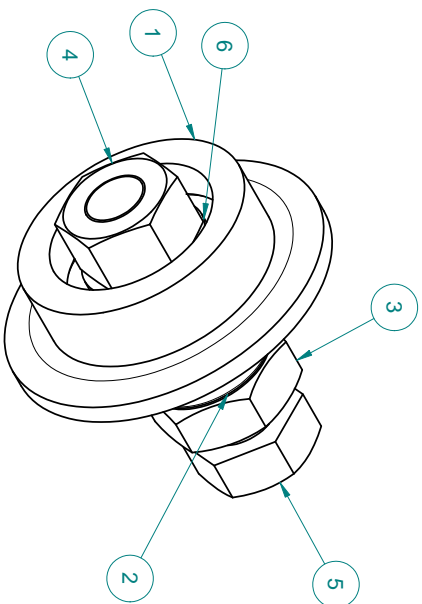

LTR	CHANGE	DATE	BY	EC NO.	LTR	CHANGE	DATE	BY	EC NO.	<p>WALKER, MICHIGAN, U.S.A. 49534-7564</p>  <p>THIS DRAWING AND ALL PROPRIETARY RIGHTS AND CONCEPTS HEREIN ARE THE EXCLUSIVE PROPERTY OF OLIVER PACKAGING AND EQUIPMENT COMPANY AND ARE NOT TO BE REPRODUCED OR TRANSMITTED IN ANY FORM OR BY ANY MEANS, ELECTRONIC OR MECHANICAL, INCLUDING PHOTOCOPYING, RECORDING, OR BY ANY INFORMATION STORAGE AND RETRIEVAL SYSTEM, WITHOUT PERMISSION OF OLIVER PACKAGING & EQUIPMENT COMPANY.</p>
NAME 5/8in (40B16) IDLER SPROCKET COMPLETE ASSY MATERIAL _____ DRAWN BY BW DATE 6-16-16 FINISH _____ SCALE 1:1 REMOVE BURRS & SHARP EDGES DO NOT SCALE THIS DRAWING DIMENSIONAL TOLERANCES UNLESS SPECIFIED FRACTIONAL ±.004 DECIMAL ±.005 ANGULAR ±1°										

0	TOOL NAME	NUMBER
---	-----------	--------

CHANGE
C 0860-1288

ITEM	PART NUMBER	DESCRIPTION	QUAN.
------	-------------	-------------	-------

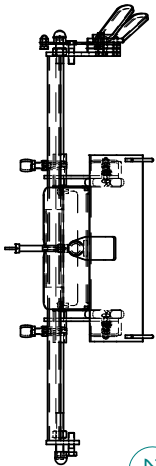
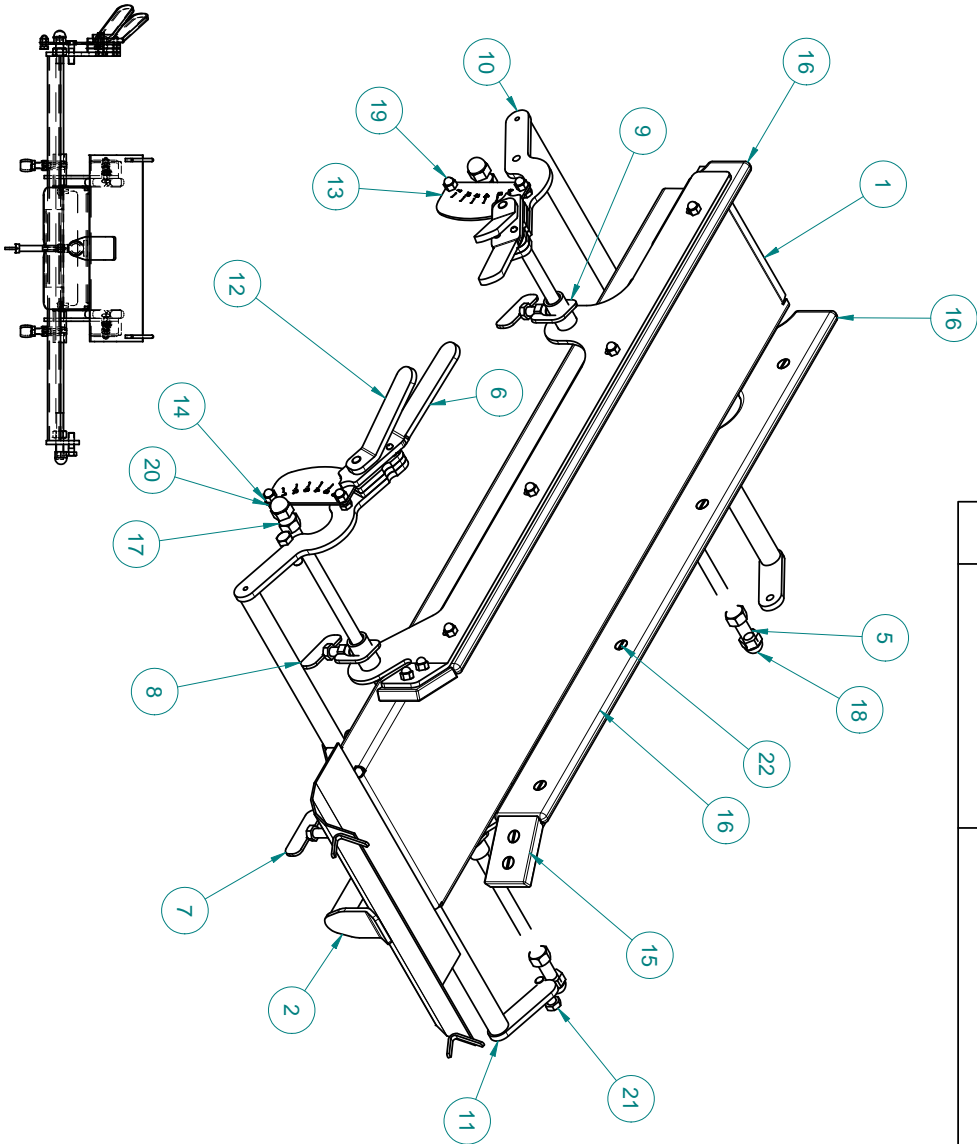
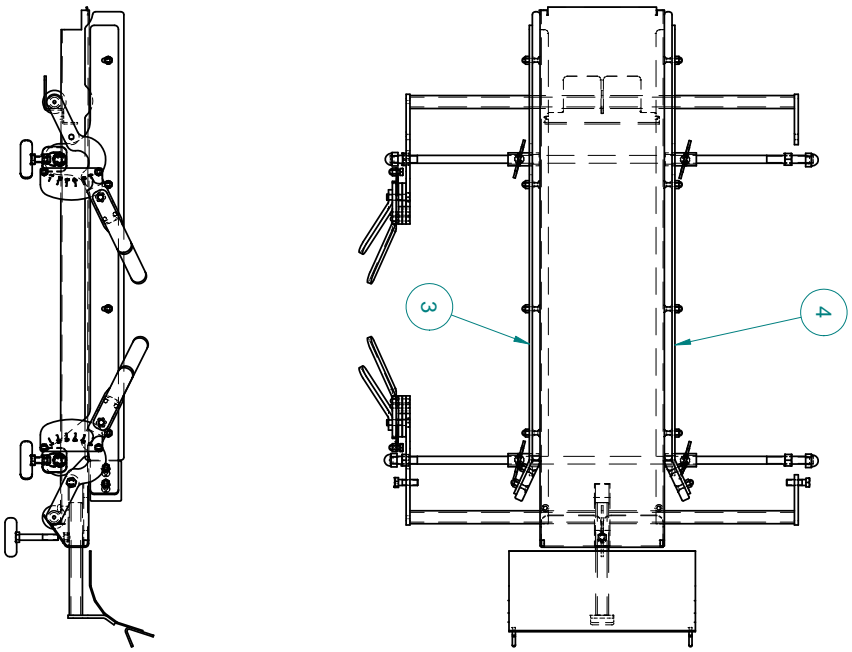

LTR	CHANGE	DATE	BY	EC NO.	LTR	CHANGE	DATE	BY	EC NO.

OLIVER

WALKER, MICHIGAN, U.S.A. 49534-7564

THIS DRAWING AND ALL PROPRIETARY RIGHTS AND CONCEPTS HEREIN ARE THE EXCLUSIVE PROPERTY OF OLIVER PACKAGING AND EQUIPMENT COMPANY AND ARE NOT TO BE REPRODUCED OR TRANSMITTED IN ANY FORM OR BY ANY MEANS, ELECTRONIC OR MECHANICAL, INCLUDING PHOTOCOPYING, RECORDING, OR BY ANY INFORMATION STORAGE AND RETRIEVAL SYSTEM, WITHOUT PERMISSION OF OLIVER PACKAGING & EQUIPMENT COMPANY.

NAME: **PRESSURE PLATE ASSEMBLY**

MATL. NO.: _____ FINISH: _____

DRAWN BY: **WHW** DATE: **6-16-16** SCALE: **1:8**

REMOVE BURRS & SHARP EDGES. DO NOT SCALE THIS DRAWING DIMENSIONAL TOLERANCES UNLESS SPECIFIED FRACTIONAL, ± 1/64 DECIMAL, ± .005/ANGULAR ± 1°

0860-1288

0	TOOL NAME	NUMBER	CHANGE	ITEM	PART NUMBER	DESCRIPTION	QUAN.
---	-----------	--------	--------	------	-------------	-------------	-------

Item Number	Part Number	Description	Qty	Item Number	Part Number	Description	Qty
1	0860-0004-32	WELDMENT-8" PRESSURE PLATE	1	19	5832-0590	NUT-ACORN 1/4-20	16
2	0860-0005	WELDMENT-RETURN PLATE	1	20	5843-1001	SCREW- HEX HD 1/4-20 X 1/2 STST	4
3	0860-0007	SIDE GUIDE ASSY WELDED RIGHT	1	21	5843-1055	SCREW- HEX HD 3/8-16 X 1-1/4 STST	4
4	0860-0008	SIDE GUIDE ASSY WELDED LEFT	1	22	5843-5085	SCREW-FLAT HEAD 1/4-20 X 1	12
5	0860-0017	SIDE GUIDE ROD	2				
6	0860-0018	PPS HANDLE	2				
7	0860-0021	BOLT-2.5" WING	1				
8	0860-0022	BOLT-1" WING	4				
9	0860-0023	SIDE GUIDE CLAMP WELDED ASSY	4				
10	0860-0041	860L LEFT PPS SUPPORT WELDED ASSY	1				
11	0860-0042	RIGHT PPS SUPPORT WELDED ASSY	1				
12	0860-0043	CLAMPING HANDLE	2				
13	0860-0059	CLAMP PLATE LEFT	1				
14	0860-0060	CLAMP PLATE RIGHT	1				
15	5501-4623	GUIDE-SHORT SIDE	2				
16	5501-4624	GUIDE-LONG SIDE	2				
17	5832-0524	NUT - HEX FULL 1/2-13NC FIN STST	4				
18	5832-0583	NUT - ACORN 1/2-13 STST	4				

LTR	CHANGE	DATE	BY	EC NO.	LTR	CHANGE	DATE	BY	EC NO.



WALKER, MICHIGAN, U.S.A. 49534-7564

THIS DRAWING AND ALL PROPRIETARY RIGHTS AND CONCEPTS HEREIN ARE THE EXCLUSIVE PROPERTY OF OLIVER PACKAGING AND EQUIPMENT COMPANY AND ARE NOT TO BE REPRODUCED OR TRANSMITTED IN ANY FORM OR BY ANY MEANS, ELECTRONIC OR MECHANICAL, INCLUDING PHOTOCOPYING, RECORDING, OR BY ANY INFORMATION STORAGE AND RETRIEVAL SYSTEM, WITHOUT PERMISSION OF OLIVER PACKAGING & EQUIPMENT COMPANY.

NAME: **PRESSURE PLATE ASSEMBLY**

DRAWN BY: _____ DATE: _____ FINISH: _____ SCALE: _____

REMOVE BARRS & SHARP EDGES
DIMENSIONAL TOLERANCES UNLESS SPECIFIED FRACTIONAL ± 1/64 DECIMAL ± .005 ANGULAR ± 1°

0	TOOL NAME	NUMBER
---	-----------	--------

CHANGE

C 0860-1388

ITEM	PART NUMBER	DESCRIPTION	QUAN.
------	-------------	-------------	-------

Item Number	Part Number	Description	Qty
1	0860-0051	DUAL CHAIN TIGHTENER WELDMENT	1
2	5115-7027	FITTING-GRS STRGHT 1/4-28	2
3	5253-0046	BEARING-1/2"ID X5/8"OD X3/4"L	2
4	5616-9042	SPROCKET, #40, 12 TOOTH, 5/8 BORE	2
5	5832-0587	NUT - ACORN 3/8-16 STST	1
6	5842-1554	SCREW - HEX HD 3/8-16 X 1	1
7	7023-5100	SPRING-TENS 1/2OD X.063WD X 5	1

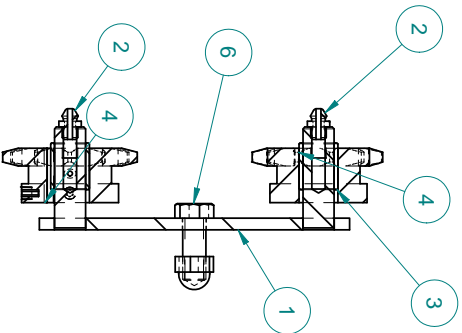
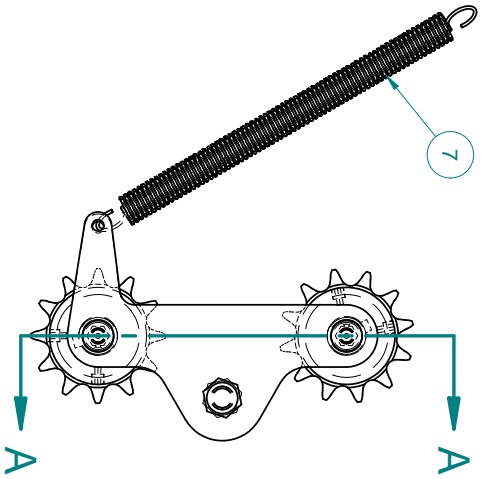
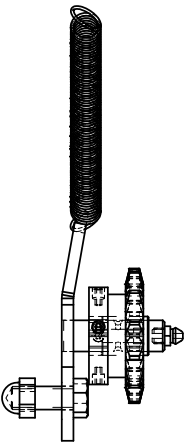

SECTION A-A

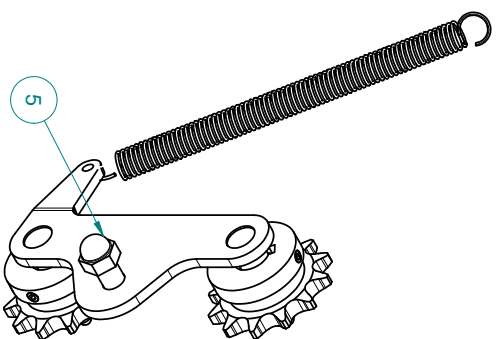

LTR	CHANGE	DATE	BY	EC NO.	LTR	CHANGE	DATE	BY	EC NO.

WALKER, MICHIGAN, U.S.A. 49534-7564

OLIVER

THIS DRAWING AND ALL PROPRIETARY RIGHTS AND CONCEPTS HEREIN ARE THE EXCLUSIVE PROPERTY OF OLIVER PACKAGING AND EQUIPMENT COMPANY AND ARE NOT TO BE REPRODUCED OR TRANSMITTED IN ANY FORM OR BY ANY MEANS, ELECTRONIC OR MECHANICAL, INCLUDING PHOTOCOPYING, RECORDING, OR BY ANY INFORMATION STORAGE AND RETRIEVAL SYSTEM, WITHOUT THE WRITTEN PERMISSION OF OLIVER PACKAGING & EQUIPMENT COMPANY.

NAME **DUAL CHAIN TIGHTENER ASSEMBLY**

MATL NO. **SEE CHART** FINISH _____ SCALE **1:2**

DRAWN BY **WHW** DATE **6-16-16**

REMOVE BURRS & SHARP EDGES DIMENSIONAL TOLERANCES UNLESS SPECIFIED FRACTIONAL ±.164 DECIMAL ±.005 ANGULAR ±1

DO NOT SCALE THIS DRAWING

0	TOOL NAME	NUMBER
---	-----------	--------

CHANGE
C 0860-1399

ITEM	PART NUMBER	DESCRIPTION	QUAN.
------	-------------	-------------	-------

Item Number	Part Number	Description	Qty
1	0860-0044	ROD-CURLING CHAIN	1
2	0860-0045	8" SASH CHAIN	18
3	5600-9925	STST CURLING CHAIN	1
4	5835-6442	7/64 X 1 STST COTTER PIN	3
5	6208-7068	1/16" DIA BEND AND STAY STST	1
6	6208-7070	1/8" DIA BENT AND STAY STST	1

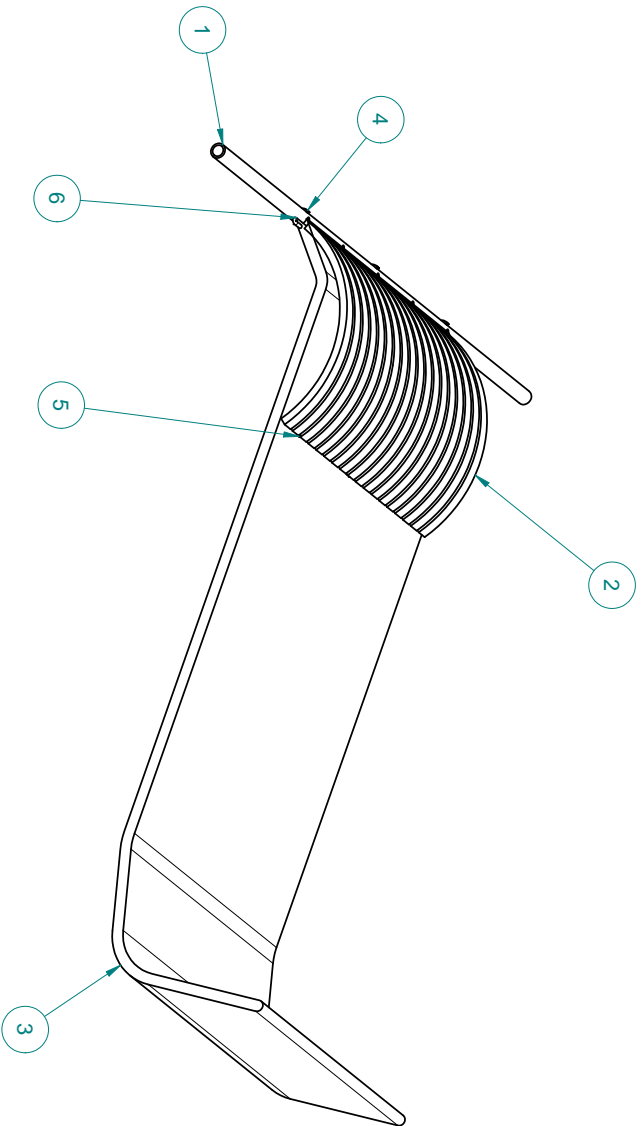

LTR	CHANGE	DATE	BY	EC NO.	LTR	CHANGE	DATE	BY	EC NO.



WALKER, MICHIGAN, U.S.A. 49834-7564

THIS DRAWING AND ALL PROPRIETARY RIGHTS AND CONCEPTS HEREIN ARE THE EXCLUSIVE PROPERTY OF OLIVER PACKAGING AND EQUIPMENT COMPANY AND ARE NOT TO BE REPRODUCED OR TRANSMITTED IN ANY FORM OR BY ANY MEANS, SUCH AS RIGHTS WITHOUT PERMISSION OF OLIVER PACKAGING & EQUIPMENT COMPANY.

NAME	CURLING CHAIN ASSEMBLY		
MATL	SEE LIST		
DRAWN BY	TELECZAN	DATE	5-2-16
MATL NO.	FINISH	SCALE	1/4

REMOVE BARRS & SHARP EDGES
 DIMENSIONAL TOLERANCES UNLESS SPECIFIED FRACTIONAL ± .004 DECIMAL ± .005 ANGULAR ± 1°

B

C

CHANGE

0860-25020

Item Number	Part Number	Description	Qty
1	0860-0084	BRACKET SWITCH	1
2	5708-7900	OPERATOR-PB GREEN FLUSH	1
3	5708-7920	OPERATOR-P-B. MUSHROOM HD RED	1
4	5708-7930	BASE-MTG/BLOCK-CONTACT NO	1
5	5708-7931	BASE-MTG/BLOCK-CONTACT NC	1
6	5757-7360	SWITCH- LIMIT SPDT ROLLER 10AMP	2
7	5765-1082	RELIEF-STRAIN 1/2NPT	6
8	5765-1120	STRAIN RELIEF M20 X 1.5	2
9	5765-4232	CLAMP - CABLE 3/8" (UL RECGNZD)	2
10	5766-7750	NUT-LOCK APPLETON # BL-50	6
11	5832-0590	NUT-ACORN 1/4-20	2
12	5843-1030	SCREW- HEX HD 5/16-18 X 1 STST	4
13	5843-5067	F.H. MACHINE SCREW, SLOTTED #10-24 X 3/8	2
14	5843-5553	SCREW-PANHD SLOT 8-32 X 3/8 STST	4
15	5851-9357	WASHER- LOCK 1/4 STST SPRING	2
16	5851-9358	WASHER-LOCK 5/16" STST 18-8	4
17	6309-1465	DRIVE-1HP VFD 115/230 1PH LENZE	1
18	6309-6035	DIAL PLATE AND KNOB KIT	1
19	6310-0500	GEARMOTOR .75 HP, 167RPM SEW	1
20*	8832-0111	NUT-HEX HD STST M4 DIN 934	2
21	8843-2277	SCREW-STST SLOTTED PAN HD M4 X 30MM	2

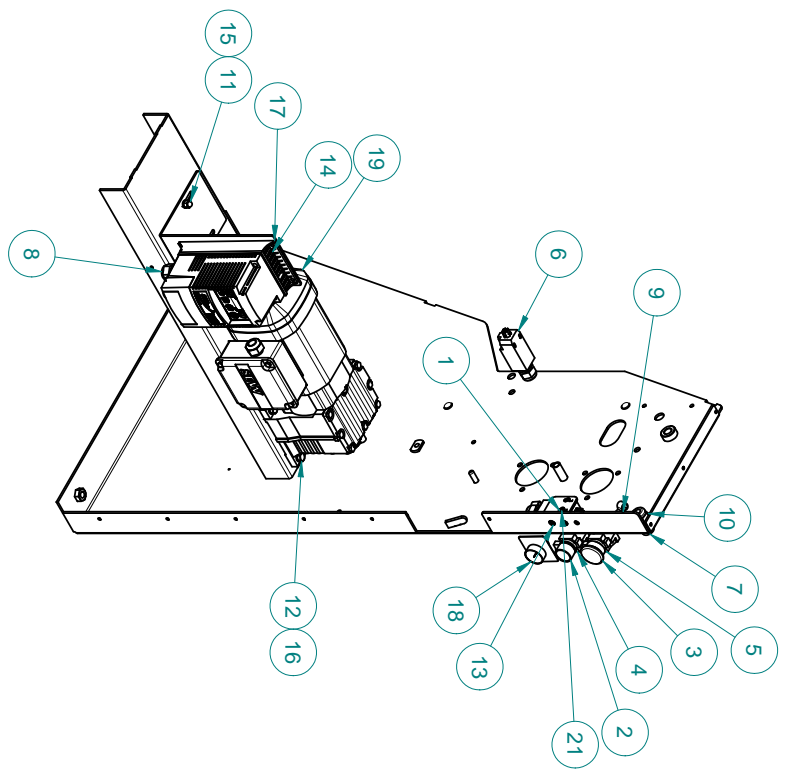

CROSS REF Error: No reference

WEIGHT 0.0 lbm

REV <revision number>

LTR	CHANGE	DATE	BY	EC NO.	LTR	CHANGE	DATE	BY	EC NO.

OLIVER

WALKER, MICHIGAN, U.S.A. 49634-7564

THIS DRAWING AND ALL PROPRIETARY RIGHTS AND CONCEPTS HEREIN ARE THE EXCLUSIVE PROPERTY OF OLIVER PRODUCTS COMPANY AND ARE NOT TO BE REPRODUCED OR TRANSMITTED IN ANY FORM OR BY ANY MEANS, SUCH AS PHOTOCOPYING, RECORDING, OR BY ANY INFORMATION STORAGE AND RETRIEVAL SYSTEM, WITHOUT PERMISSION OF OLIVER PRODUCTS COMPANY.

NAME: **860L ELECTRICS**

PROJECT: **68-6801 PROJECT**

DATE: **5/26/2016**

SCALE: **1:1**

DRAWN BY: **webb**

FINISH: **Error: No reference**

REVISIONS: **Error: No reference**

REMOVE BIRDS & SHARP EDGES

DIMENSIONAL TOLERANCES UNLESS SPECIFIED: FRACTIONAL: ±.004; DECIMAL: ±.005; ANGULAR: ±1°

DO NOT SCALE THIS DRAWING

0	TOOL NAME	NUMBER

ITEM	PART NUMBER	DESCRIPTION	QUAN.

C0860 - C12001

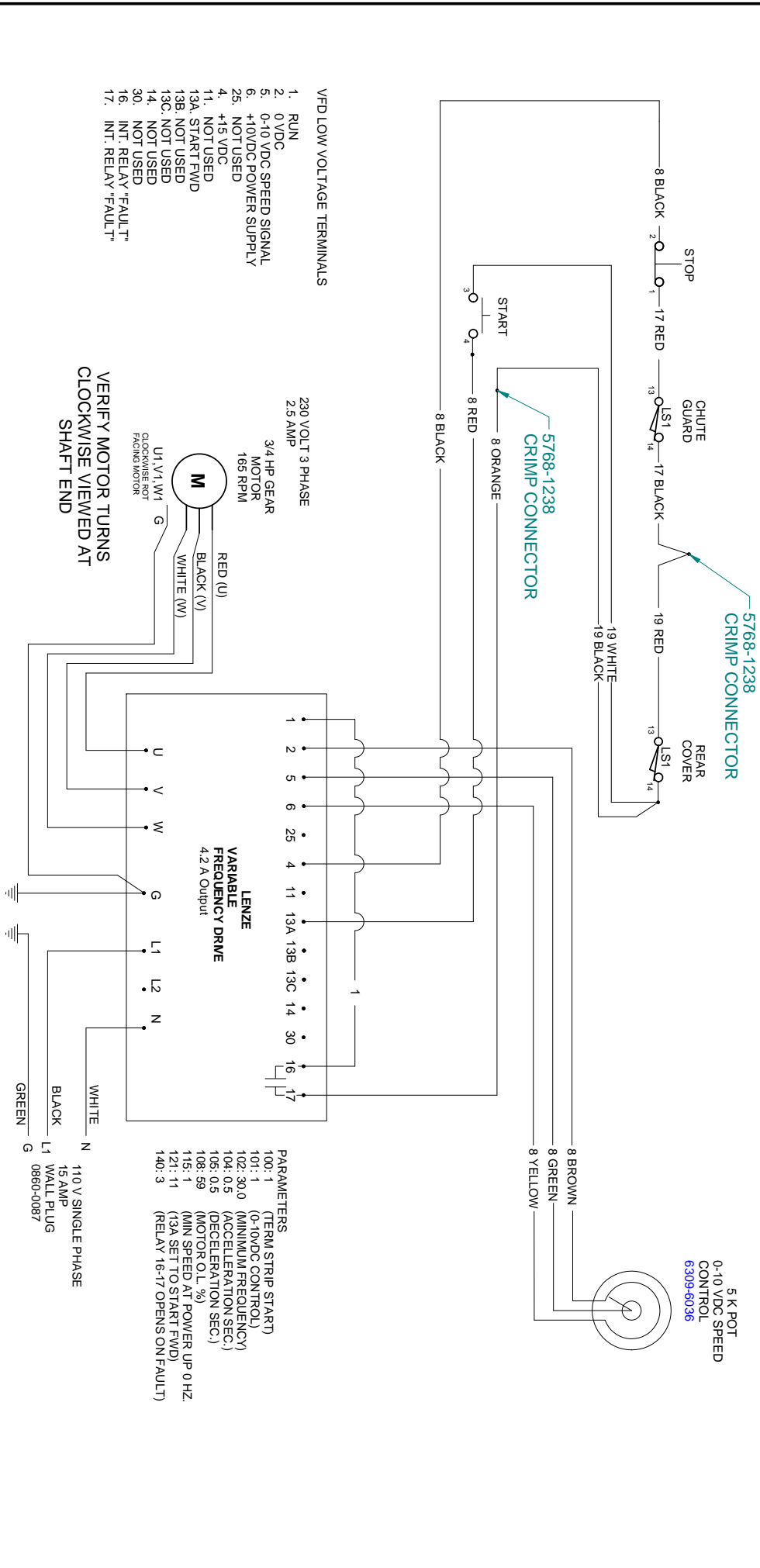

LTR	CHANGE	DATE	BY	EC NO.	LTR	CHANGE	DATE	BY	EC NO.

WALKER, MICHIGAN, U.S.A. 49534-7564

OLIVER

THIS DRAWING AND ALL PROPRIETARY RIGHTS AND CONCEPTS HEREIN ARE THE EXCLUSIVE PROPERTY OF OLIVER PACKAGING AND EQUIPMENT COMPANY AND ARE NOT TO BE REPRODUCED OR TRANSMITTED IN ANY FORM OR BY ANY MEANS, WITHOUT PERMISSION OF OLIVER PACKAGING & EQUIPMENT COMPANY.

NAME: **860 MOLDER 1/60/115 ELECTRICS**

DRAWN BY: **JCK** DATE: **8/19/16** FINISH: _____ SCALE: _____

REVISIONS & CHANGES: _____

DATE: _____

0	TOOL NAME	NUMBER

ITEM	PART NUMBER	DESCRIPTION	QUAN.

CHANGE C10860 - C12002

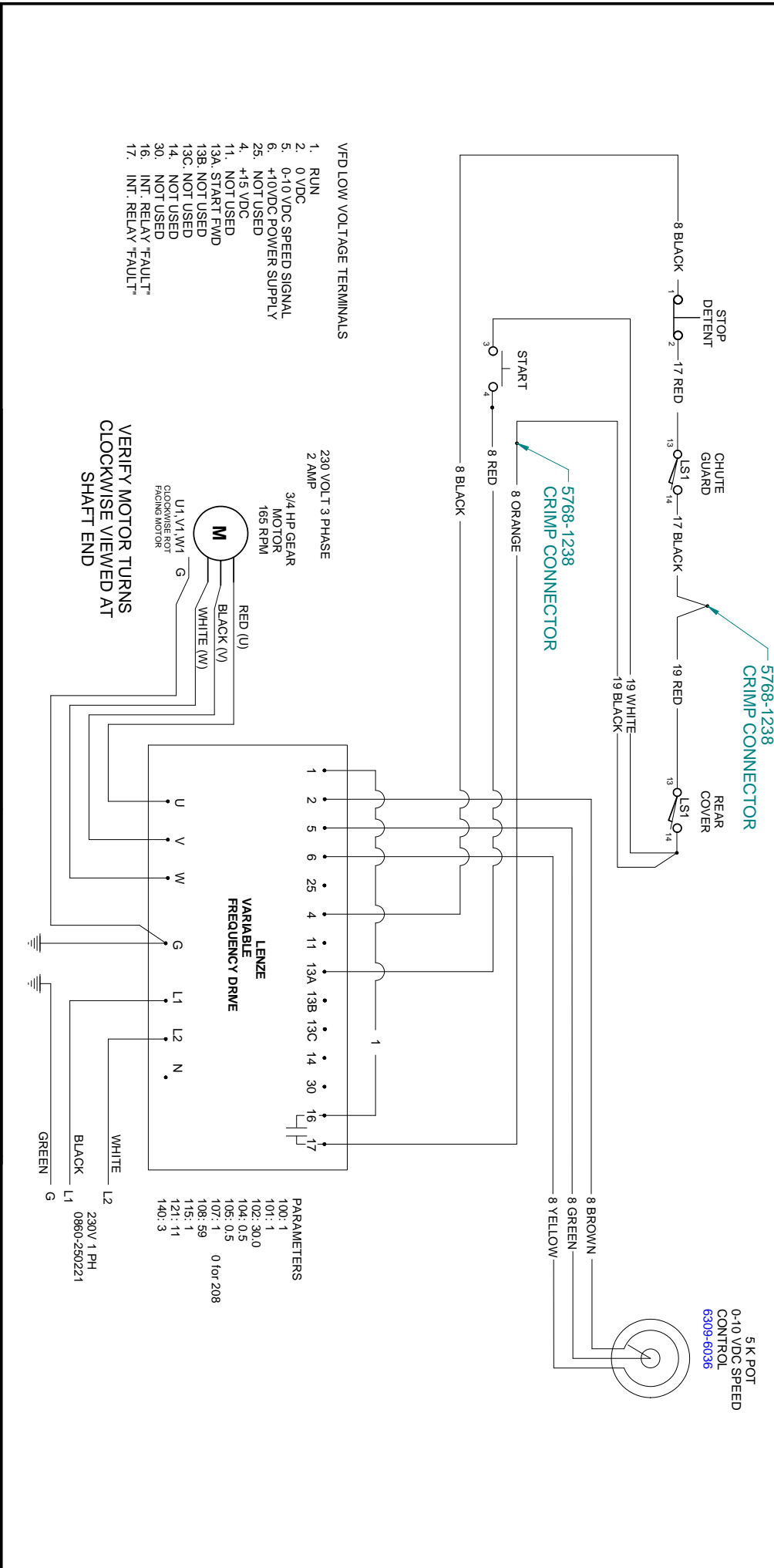

LTR	CHANGE	DATE	BY	EC NO.	LTR	CHANGE	DATE	BY	EC NO.



WALKER, MICHIGAN, U.S.A. 49534-7564

THIS DRAWING AND ALL PROPRIETARY RIGHTS AND CONCEPTS HEREIN ARE THE EXCLUSIVE PROPERTY OF OLIVER PACKAGING AND EQUIPMENT COMPANY AND ARE NOT TO BE REPRODUCED OR TRANSMITTED IN ANY FORM OR BY ANY MEANS, ELECTRONIC OR MECHANICAL, INCLUDING PHOTOCOPYING, RECORDING, OR BY ANY INFORMATION STORAGE AND RETRIEVAL SYSTEM, WITHOUT PERMISSION OF OLIVER PACKAGING & EQUIPMENT COMPANY.

NAME	860L ELECTRICS 230 V 1 PH
DRAWN BY	JCW
DATE	5/27/16
SCALE	
FINISH	



Oliver Packaging & Equipment Company
3236 Wilson Drive NW, Walker, MI 49534
(800) 53-3893

WARRANTY PROCEDURE

1. If a problem should occur, either the dealer or the end user must contact the Parts and Service Department and explain the problem.
2. The Parts and Service Manager will determine if the warranty will apply to this particular problem.
3. If the Parts and Service Manager approves, a Work Authorization Number will be generated, and the appropriate service agency will perform the service.
4. The service dealer will then complete an invoice and send it to the Parts and Service Department at Oliver Packaging & Equipment Company.
5. The Parts and Service Manager of Oliver Packaging and Equipment Company will review the invoice and returned parts, if applicable, and approve for payment.



3236 Wilson Drive NW, Walker, MI 49534
800-253-3893 | www.oliverquality.com

RETURNED PARTS POLICY

This policy applies to all parts returned to the factory whether for warranted credit, replacement, repair or re-stocking.

Oliver Packaging and Equipment Company requires that the customer obtain a Return Material Authorization (RMA) number before returning any part. This number should appear on the shipping label and inside the shipping carton as well. All parts are to be returned prepaid. Following this procedure will insure prompt handling of all returned parts.

To obtain an RMA number contact the Repair Parts Department toll free at (800) 253-3893.

Parts returned for re-stocking are subject to a **RE-STOCKING CHARGE**.

Thank you for your cooperation,

Repair Parts Manager
Oliver Packaging and Equipment Company

WARRANTY

PARTS

Oliver Packaging & Equipment Company warrants that if any part of the equipment (other than a part not manufactured by Oliver) proves to be defective (as defined below) within one year after shipment, and if Buyer returns the defective part to Oliver Packaging & Equipment within one year, Freight Prepaid to Oliver Packaging & Equipment's plant in Grand Rapids, MI, then Oliver Packaging & Equipment, shall, at Oliver Packaging & Equipment's option, either repair or replace the defective part, at Oliver Packaging & Equipment's expense.

LABOR

Oliver Packaging & Equipment further warrants that equipment properly installed in accordance with our special instructions, which proves to be defective in material or workmanship under normal use within one (1) year from installation or one (1) year from actual shipment date, whichever date comes first, will be repaired by Oliver Packaging & Equipment or an Oliver Packaging & Equipment Authorized Service Dealer, in accordance with Oliver Packaging & Equipment's published Service Schedule.

For purposes of this warranty, a defective part or defective equipment is a part or equipment which is found by Oliver Packaging & Equipment to have been defective in materials workmanship, if the defect materially impairs the value of the equipment to Buyer. Oliver Packaging & Equipment has no obligation as to parts or components not manufactured by Oliver Packaging & Equipment, but Oliver Packaging & Equipment assigns to Buyer any warranties made to Oliver Packaging & Equipment by the manufacturer thereof.

This warranty **does not** apply to:

1. Damage caused by shipping or accident.
2. Damage resulting from improper installation or alteration.
3. Equipment misused, abused, altered, not maintained on a regular basis, operated carelessly, or used in abnormal conditions.
4. Equipment used in conjunction with products of other manufacturers unless such use is approved by Oliver Packaging & Equipment in writing.
5. Periodic maintenance of equipment, including but not limited to lubrication, replacement of wear items, and other adjustments required due to installation, set up, or normal wear.
6. Losses or damage resulting from malfunction.

The foregoing warranty is in lieu of all other warranties expressed or implied AND OLIVER PACKAGING & EQUIPMENT MAKES NO WARRANTY OF MERCHANTABILITY OR FITNESS FOR PURPOSE REGARDING THE EQUIPMENT COVERED BY THIS WARRANTY. Oliver Packaging & Equipment neither assumes nor authorizes any person to assume for it any other obligations or liability in connection with said equipment. OLIVER PACKAGING & EQUIPMENT SHALL NOT BE LIABLE FOR LOSS OF TIME, INCONVENIENCE, COMMERCIAL LOSS, INCIDENTAL OR CONSEQUENTIAL DAMAGES.