



Reach In Bottle Coolers

*Models BB-CN-0005-HC, 0014-HC, 0017-HC, 0026-HC
Items 50038, 50039, 50040, 50041*

Instruction Manual



Revised - 08/23/2019



Intertek



Intertek

Toll Free: 1-800-465-0234
Fax: 905-607-0234
Email: service@omcan.com
www.omcan.com

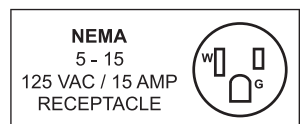

Table of Contents

Model BB-CN-0005-HC / Model BB-CN-0014-HC
Model BB-CN-0017-HC / Model BB-CN-0026-HC

Section	Page
General Information -----	3 - 4
Safety and Warranty -----	4 - 5
Technical Specifications -----	6
Installation / Operation -----	6 - 8
Maintenance -----	8 - 9
Troubleshooting -----	9 - 10
Parts Breakdown -----	11 - 18
Electrical Schematics -----	19 - 22
Warranty Registration -----	23



General Information

Omcan Manufacturing and Distributing Company Inc., Food Machinery of America, Inc. dba Omcan and Omcan Inc. are not responsible for any harm or injury caused due to any person's improper or negligent use of this equipment. The product shall only be operated by someone over the age of 18, of sound mind, and not under the influence of any drugs or alcohol, who has been trained in the correct operation of this machine, and is wearing authorized, proper safety clothing. Any modification to the machine voids any warranty, and may cause harm to individuals using the machine or in the vicinity of the machine while in operation.

CHECK PACKAGE UPON ARRIVAL

Upon receipt of an Omcan shipment please inspect for external damage. If no damage is evident on the external packaging, open carton to ensure all ordered items are within the box, and there is no concealed damage to the machine. If the package has suffered rough handling, bumps or damage (visible or concealed), please note it on the bill of lading before accepting the delivery and contact Omcan within 24 hours, so we may initiate a claim with the carrier. A detailed report on the extent of the damage caused to the machine must be filled out within three days, from the delivery date shown in the shipping documents. Omcan has no recourse for damaged products that were shipped collect or third party.

Before operating any equipment, always read and familiarize yourself with all operation and safety instructions.

Omcan would like to thank you for purchasing this machine. It's of the utmost importance to save these instructions for future reference. Also save the original box and packaging for shipping the equipment if servicing or returning of the machine is required.

Omcan Fabrication et distribution Compañie Limité et Food Machinery d'Amérique, dba Omcan et Omcan Inc. ne sont pas responsables de tout dommage ou blessure causé du fait que toute personne ait utilisé cet équipement de façon irrégulière. Le produit ne doit être exploité que par quelqu'un de plus de 18 ans, saine d'esprit, et pas sous l'influence d'une drogue ou d'alcool, qui a été formé pour utiliser cette machine correctement, et est vêtu de vêtements de sécurité approprié. Toute modification de la machine annule toute garantie, et peut causer un préjudice à des personnes utilisant la machine ou des personnes à proximité de la machine pendant son fonctionnement.

VÉRIFIEZ LE COLIS DÈS RÉCEPTION

Dès réception d'une expédition d'Omcan veuillez inspecter pour dommages externes. Si aucun dommage n'est visible sur l'emballage externe, ouvrez le carton afin de s'assurer que tous les éléments commandés sont dans la boîte, et il n'y a aucun dommage dissimulé à la machine. Si le colis n'a subi aucune mauvaises manipulations, de bosses ou de dommages (visible ou cachée), notez-le sur le bond de livraison avant d'accepter la livraison et contactez Omcan dans les 24 heures qui suivent, pour que nous puissions engager une réclamation auprès du transporteur. Un rapport détaillé sur l'étendue des dommages causés à la machine doit être rempli dans un délai de trois jours, à compter de la date de livraison indiquée dans les documents d'expédition. Omcan n'a aucun droit de recours pour les produits endommagés qui ont été expédiés ou cueilli par un tiers transporteur.

General Information

Avant d'utiliser n'importe quel équipement, toujours lire et vous familiariser avec toutes les opérations et les consignes de sécurité.

Omcan voudrais vous remercier d'avoir choisi cette machine. Il est primordial de conserver ces instructions pour une référence ultérieure. Également conservez la boîte originale et l'emballage pour l'expédition de l'équipement si l'entretien ou le retour de la machine est nécessaire.

Omcan Empresa De Fabricacion Y Distribucion Inc. Y Maquinaria De Alimentos De America, Inc. dba Omcan y Omcan Inc. no son responsables de ningun daño o perjuicio causado por cualquier persona inadecuada o el uso descuidado de este equipo. El producto solo podra ser operado por una persona mayor de 18 años, en su sano juicio y no bajo alguna influencia de droga o alcohol, y que este ha sido entrenado en el correcto funcionamiento de esta máquina, y ésta usando ropa apropiada y autorizada. Cualquier modificación a la máquina anula la garantía y puede causar daños a las personas usando la máquina mientras esta en el funcionamiento.

REVISE EL PAQUETE A SU LLEGADA

Tras la recepcion de un envio Omcan favor inspeccionar daños externos. Si no hay daños evidentes en el empaque exterior, Habra el carton para asegurarse que todos los articulos solicitados estén dentro de la caja y no encuentre daños ocultos en la máquina. Si el paquete ha sufrido un manejo de poco cuidado, golpes o daños (visible o oculto) por favor anote en la factura antes de aceptar la entrega y contacte Omcan dentro de las 24 horas, de modo que podamos iniciar una reclamación con la compañía. Un informe detallado sobre los daños causados a la máquina debe ser llenado en el plazo de tres días, desde la fecha de entrega que se muestra en los documentos de envío. Omcan no tiene ningun recurso por productos dañados que se enviaron a recoger por terceros.

Antes de utilizar cualquier equipo, siempre lea y familiarizarse con todas las instrucciones de funcionamiento y seguridad.

Omcan le gustaría darle las gracias por la compra de esta máquina. Es de la mayor importancia para salvar estas instrucciones para futuras consultas. Además, guarda la caja original y el embalaje para el envío del equipo si servicio técnico o devolución de la máquina que se requiere.

Safety and Warranty

Please pay close attention to the safety notices in this section. Disregarding these notices may lead to serious injury and/or damage to the unit.

ATTENTION

- To minimize shock and fire hazards, be sure not to overload outlet. Please designate one outlet for your unit.



Safety and Warranty

- Do not use extension cords.
- Do not put your hands under the unit when the units is required to be moved.
- When the unit is not in use for a long period of time, please unplug the unit from the outlet.
- After unplugging the unit, wait at least 10 minutes before re-plugging it. Failure to do so could cause damage to the compressor.

UNPLUG CORD

- To minimize shock and fire hazards, please do not plug or unplug the cord with wet hands.
- During maintenance and cleaning, please unplug the unit.

PROPER GROUNDING REQUIRED

- To minimize shock and fire hazards, make sure that the unit is properly grounded.

PROHIBITION

- Do not attempt to remove or repair any component unless instructed by factory.
- Make sure that the unit is not resting on or against the electrical cord and plug.
- To minimize personal injury, do not hang on the doors.
- Do not store any flammable and explosive gas or liquids inside the unit.
- Do not attempt to alter or tamper with the electrical cord.
- Do not set the desired temperature out of the recommended temperature range: (Ref: 32°F - 50°F).

2 YEARS PARTS AND LABOUR / 5 YEARS PARTS ONLY ON COMPRESSOR WARRANTY

Within the warranty period, contact Omcan Inc. at 1-800-465-0234 to schedule an Omcan authorized service technician to repair the equipment locally.

Unauthorized maintenance will void the warranty. Warranty covers electrical and part failures, not improper use.

Please see <https://omcan.com/disclaimer> for complete info.

WARNING:

The packaging components are classified as normal solid urban waste and can therefore be disposed of without difficulty.

In any case, for suitable recycling, we suggest disposing of the products separately (differentiated waste) according to the current norms.

DO NOT DISCARD ANY PACKAGING MATERIALS IN THE ENVIRONMENT!

Technical Specifications

Model	BB-CN-0005-HC	BB-CN-0014-HC	BB-CN-0017-HC	BB-CN-0026-HC
Product Capacity	12 oz bottles - 4.5 cases 12 oz cans - 6 cases	12 oz. bottles - 16.5 cases 12 oz. cans - 24 cases	12 oz. bottles - 22 cases 12 oz. cans - 32 cases	12 oz. bottles - 37.5 cases 12 oz. cans - 55 cases
Power	1/6 HP			1/4 HP
Net Volume	141 L / 5 cu.ft.	382 L / 13.5 cu.ft.	488 L / 17.23 cu.ft.	580 L / 20.5 cu.ft.
Temperature Range	0.5 - 3.3°C / 33 - 38°F			
Electrical	115V / 60Hz / 1Ph			
Amps	2.04A	2.28A	2.6A	4.2A
Refrigerant	R290			
Isolation Material	Cyclopentane			
Cooling System	Ventilated			
Defrosting	Automatic			
Dimensions	28.1" x 26.4" x 34.2" 714 x 670 x 869mm	28" x 49.5" x 34.2" 713 x 1257 x 869mm	28" x 64.5" x 34.2" 713 x 1638 x 869mm	28" x 95.2" x 34.2" 713 x 2418 x 869mm
Interior Dimensions	22.3" x 23" x 15.7" 566 x 584 x 399mm	23" x 45" x 26" 584 x 1143 x 660mm	23" x 60" x 26" 584 x 1524 x 600mm	23" x 91" x 26" 583 x 2314 x 662mm
Weight	154 lbs. / 69.9 kgs.	181 lbs. / 82 kgs.	253 lbs. / 115 kgs.	341.7 lbs. / 155 kgs.
Item Number	50038	50039	50040	50041

Installation / Operation

IMPORTANT!!!PLEASE READ BEFORE INSTALLATION

- If the unit has recently been transported. Please let unit stand still for a minimum of 24 hours before plugging it in.
- Make sure that the unit drops down to desired temperature before loading the unit with product.
- Make sure that there is proper ventilation around the unit in the area where it will operate.
- Make sure all accessories are installed(i.e. shelves, shelf clips, casters) before plugging the unit in.
- Please read through the Operation / Owners Manual in its entirety.

CABINET LOCATION GUIDELINES

- Install the unit on strong and leveled surfaces.
 - Unit may make unpleasant noises if surface is uneven.



Installation / Operation

- Unit may malfunction if surface is uneven.
- Install the unit in an indoor, well-ventilated area.
 - Unit performs more efficiently in a well-ventilated area.
 - For best performance, please maintain clearance of 6" on the back of the unit.
 - Outdoor use may cause decreased efficiency and damage to the unit.
- Avoid installation in a high humidity and/or dusty area.
 - Humidity could cause unit to rust and decrease efficiency of the unit.
 - Dust collected on condenser coil will cause unit to malfunction. Clean the condenser at least once a month with a brush or clean cloth.
- Select a location away from heat and moisture-generating equipment.
 - High ambient temperature will cause the compressor to overwork, leading to higher energy bills and gradual breakdown of the unit.

ELECTRICAL

Please ensure that the required voltage of the compressor is being supplied at all times. Low or high voltage can detrimentally affect the refrigeration unit. All units should be plugged into a grounded and properly-sized electrical outlet with appropriate overcurrent protection. Please refer to the electrical requirement on the nameplate. Please make sure that your unit has its own dedicated outlet. Do not use an extension cord.

TEMPERATURE CONTROLS

The temperature controls are factory-set to maintain an average temperature of 38°F in refrigeration. To maintain a different temperature, simply adjust the control knob located inside the unit. To decrease the temperature (colder), turn clockwise. To increase the temperature (warmer), turn counter-clockwise – see diagram.

LOADING PRODUCT

The bin dividers have been installed at the factory for your convenience. Feel free to reposition the dividers as you see fit. To remove the bin dividers, simply push the divider towards the back wall until the front of the divider is removed from the positioning holes. To install, position the divider to the desired holes, making sure that the pressure spring is installed properly.

PAY CLOSE ATTENTION TO THE LOAD LIMIT STICKERS LOCATED ON THE INTERIOR WALLS TO THE UNIT. DO NOT LOAD PRODUCT ABOVE THE LOAD LIMIT STICKERS OR ABOVE THE TOP CROSS BAR OF THE BIN DIVIDERS. LOADING PRODUCT ABOVE THE LOAD LIMIT STICKERS WILL HARM THE PERFORMANCE OF THE UNIT.

Installation / Operation

CAUTION

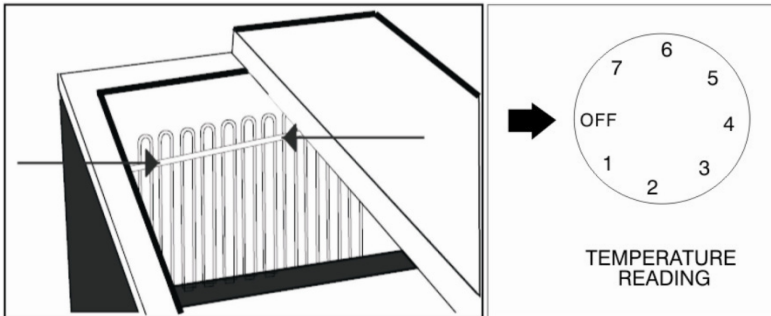

Setting the temperature control to the coldest setting may cause the Evaporator coil to freeze and ice up. This will eventually result in a warmer Cabinet temperature.

Temperature range from 7 (coldest) to 1 (warmest).

Do not load Product above the top crossbar. Doing so will harm the Refrigeration.

MECHANICAL CONTROLLER INSTRUCTIONS

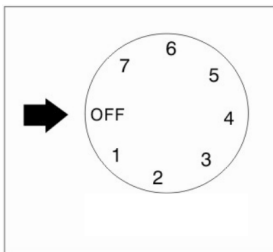

OFF: shut the compressor off

Temperature range from 7 (coldest) to 1 (warmest).

CAUTION: Setting the temperature control to the coldest setting may cause the evaporator coil to freeze and ice up. This will eventually result in a warmer cabinet temperature.

Maintenance

CLEANING THE CONDENSER COIL

- For efficient operation, it is important that the condenser surface be kept free of dust, dirt, and lint.
- We recommend cleaning the condenser coil and fins at least once per month.
- Clean with a commercial condenser coil cleaner, available from any kitchen equipment retailer. Brush the condenser fins from top to bottom, not side to side.
- After cleaning, straighten any bent condenser fins with a fin comb.

CLEANING THE FAN BLADE AND MOTOR

- If necessary, clean the fan blades and motor with a soft cloth. If it is necessary to wash the fan blades, cover the fan motor to prevent moisture damage.

CLEANING THE INTERIOR OF UNIT

- When cleaning the cabinet interior, use a solvent of warm water and mild soap.
- Do not use steel wool, caustic soap, abrasive cleaners, or bleach that may damage the stainless steel

Maintenance

surface.

- Wash door gaskets on a regular basis, preferably weekly. Simply remove door gasket from the frame of the door, soak in warm water and soap for thirty (30) minutes, dry with soft cloth, and replace.
- Check door gaskets for proper seal after they are replaced.
- Periodically remove the shelves and pilasters from the unit and clean them with mild soap and warm water. To remove the pilasters, first remove the shelves and shelf brackets. Then, simply lift the pilaster up and out.

WARNING: Disconnect power cord before cleaning any parts of the unit.

Troubleshooting

Before requesting any service on your unit, please check the following points. Please note that this guide serve only as a reference for solutions to common problems.

PROBLEM	POSSIBLE CAUSE	CORRECTIVE ACTION
Compressor not running.	Fuse blown or circuit breaker tripped.	Replace fuse or reset circuit breaker.
	Power cord unplugged.	Plug in power cord.
	Thermostat set too high.	Set thermostat to lower Temperature.
	Cabinet in defrost cycle.	Wait for defrost cycle to finish.
Condensing unit runs for long periods of time.	Excessive amount of warm product Placed in cabinet.	Allow adequate time for Product to cool down.
	Prolonged door opening or door ajar.	Ensure doors are closed when not in use. Avoid opening doors for long periods of time.
	Door gasket(s) not sealing properly.	Ensure gaskets are snapped in Completely. Remove gasket and Wash with soap and water. Check condition of gasket and Replace if necessary.
	Dirty condenser coil.	Clean the condenser coil.
	Evaporator coil iced over.	Unplug unit and allow coil to defrost. Make sure thermostat is not set too cold. Ensure that door gasket(s) are sealing properly.

Troubleshooting

Cabinet Temperature Is too warm.	Thermostat set too warm.	Set thermostat to lower Temperature.
	Blocking air flow.	Re-arrange product to allow for Proper air flow. Make sure there Is at least four inches of clearance from evaporator.
	Excessive amount of warm product Placed in cabinet.	Allow adequate time for product to cool down.
	Fuse blown or circuit breaker tripped.	Replace fuse or reset circuit breaker.
	Dirty condenser coil.	Clean the condenser coil.
	Prolonged door opening or door ajar.	Ensure doors are closed when not in use. Avoid opening doors for long periods of time.
	Evaporator coil iced over.	(See above)
Cabinet is noisy.	Loose part(s).	Locate and tighten loose part(s).
	Tubing vibration.	Ensure tubing is free from contact with other tubing or components.

For service call 1-800-465-0234.

REFERENCE

Item Number	Model Number	Description	Manufacturer Model Number
50038	BB-CN-0005-HC	Cooler Back Bar 5 cu ft Reach In 115V/60/1 ETL cETLus INTERTEK	JBC-25-HC
50039	BB-CN-0014-HC	Cooler Back Bar 13.5 cu ft Reach In 115V/60/1 ETL cETLus INTERTEK	JBC-50-HC
50040	BB-CN-0017-HC	Cooler Back Bar 17.2 cu ft Reach In 115V/60/1 ETL cETLus INTERTEK	JBC-65-HC
50041	BB-CN-0026-HC	Cooler Back Bar 25.8 cu ft Reach In 115V/60/1 ETL cETLus INTERTEK	JBC-95-HC

Parts Breakdown

Model BB-CN-0005-HC 50038

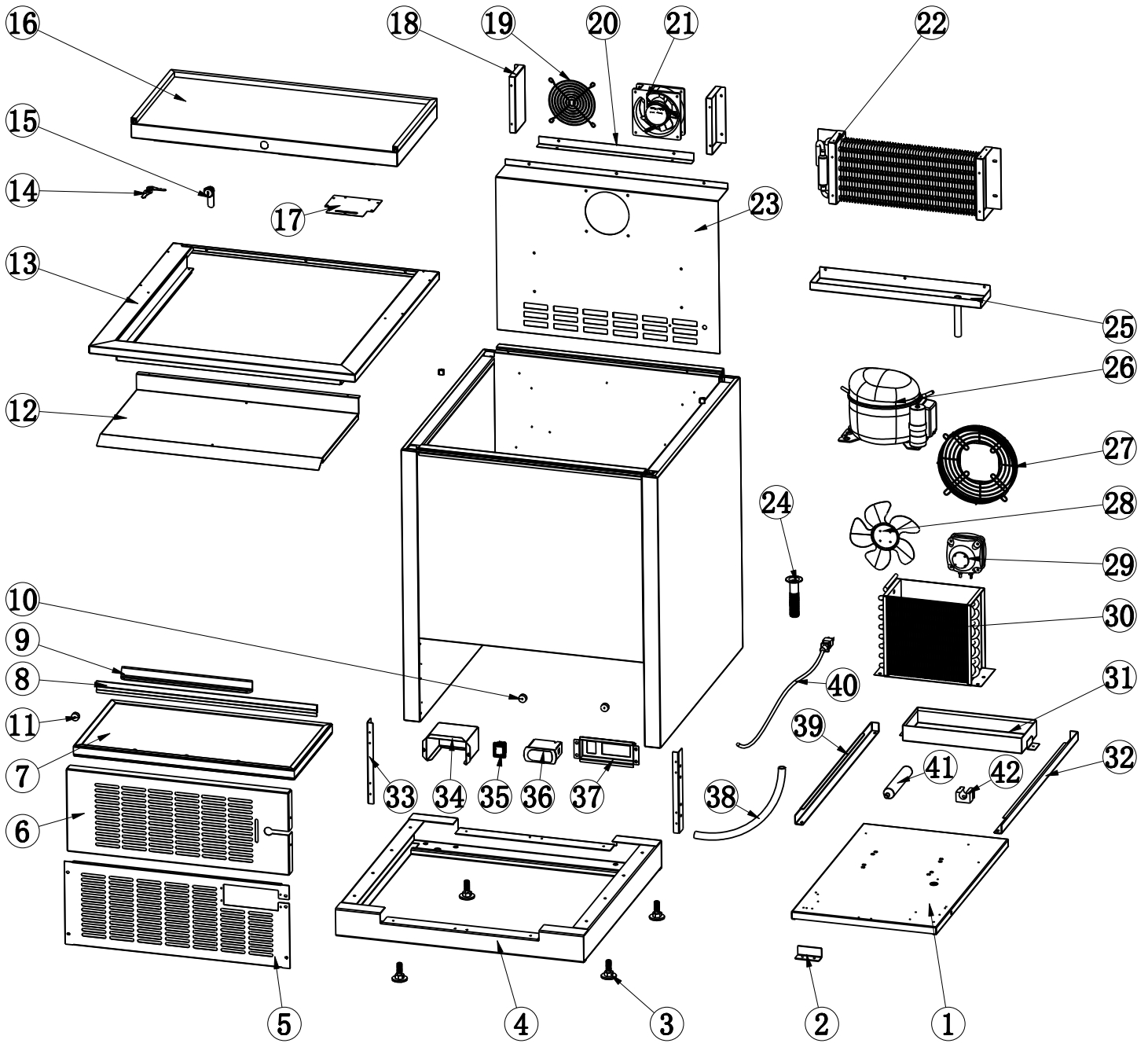

Parts Breakdown

Model BB-CN-0005-HC 50038

Item No.	Description	Position	Item No.	Description	Position	Item No.	Description	Position
AA183	Compressor Unit Installation Board for JBC-25-HC	1	AA197	Lock for JBC-25-HC	15	AA209	Condenser Fan Motor for JBC-25-HC	29
AA184	Installation Board Limited Block for JBC-25-HC	2	AA198	Top Board for JBC-25-HC	16	AA210	Condenser for JBC-25-HC	30
AA185	Leveling Feet for JBC-25-HC	3	AA199	Base Board for Lock for JBC-25-HC	17	AA211	Outer Drain Pan for JBC-25-HC	31
AA186	Cabinet Base for JBC-25-HC	4	AA200	Evaporator Fan Right and Left Baffle for JBC-25-HC	18	AA212	Right Rail for Installation Board for JBC-25-HC	32
AA187	Front Grill for JBC-25-HC	5	AA201	Evaporator Fan Motor Cover for JBC-25-HC	19	AA213	Fixer for Front Grill for JBC-25-HC	33
AA188	Back Grill for JBC-25-HC	6	AA202	Evaporator Fan Bottom Baffle for JBC-25-HC	20	AA214	Thermostat Water Proof Cover for JBC-25-HC	34
AA189	Door for JBC-25-HC	7	AA128	Evaporator Fan Motor for JBC-25-HC	21	AA124	Power Switch for JBC-25-HC	35
AA190	Door Gasket for JBC-25-HC	8	AA203	Evaporator for JBC-25-HC	22	AA123	Thermostat for JBC-25-HC	36
AA191	Door Handle for JBC-25-HC	9	AA204	Evaporator Cover for JBC-25-HC	23	AA215	Thermostat Installation Cover for JBC-25-HC	37
AA192	Back Limit Block for JBC-25-HC	10	AA205	Inner Drain Pipe for JBC-25-HC	24	AA216	Drain Tube for JBC-25-HC	38
AA193	Door Limit Block for JBC-25-HC	11	AA206	Inner Drain Pan for JBC-25-HC	25	AA217	Left Rail for Installation Board for JBC-25-HC	39
AA194	Panel Under Table for JBC-25-HC	12	64172	Compressor for JBC-25-HC	26	AA135	Power Cord for JBC-25-HC	40
AA195	Under Table Component for JBC-25-HC	13	AA207	Condenser Fan Motor Cover for JBC-25-HC	27	AA130	Filter for JBC-25-HC	41
AA196	Key for JBC-25-HC	14	AA208	Condenser Fan Blade for JBC-25-HC	28	AA129	Filter Fixer for JBC-25-HC	42

Parts Breakdown

Model BB-CN-0014-HC 50039

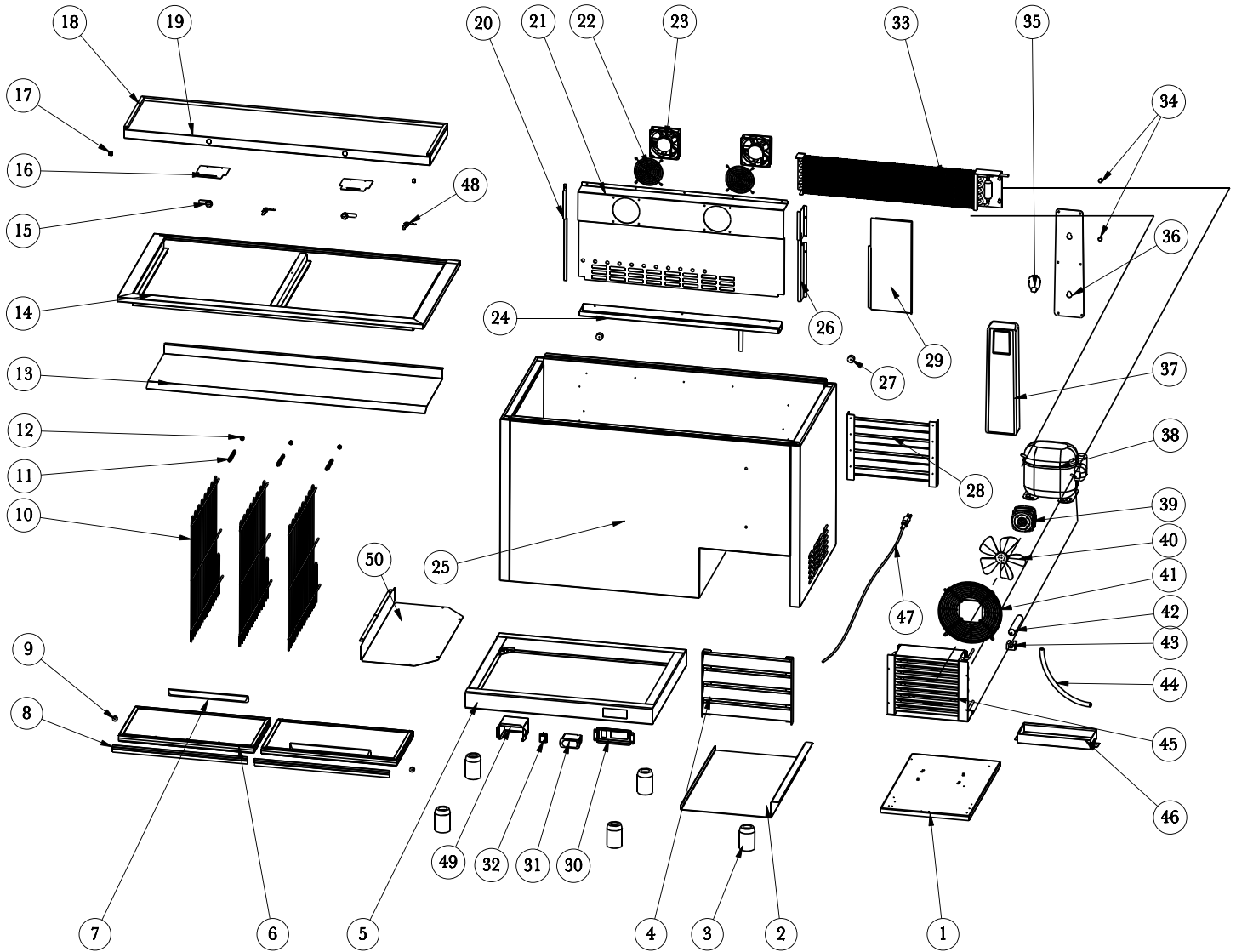

Parts Breakdown

Model BB-CN-0014-HC 50039

Item No.	Description	Position	Item No.	Description	Position	Item No.	Description	Position
AA218	Compressor Unit Installation Board for JBC-50-HC	1	AA232	Decoration Strip for JBC-50-HC	18	AA244	Bottle Opener for JBC-50-HC	35
AA219	Base Board for JBC-50-HC	2	AA233	Top Board for JBC-50-HC	19	AA245	Bottle Opener Board for JBC-50-HC	36
AA185	Leveling Feet for JBC-50-HC	3	AA234	Left Support for Evaporator Cover for JBC-50-HC	20	AA246	Bottle Opener Cover for JBC-50-HC	37
AA220	Front Grill for JBC-50-HC	4	AA235	Evaporator Cover for JBC-50-HC	21	64172	Compressor for JBC-50-HC	38
AA221	Cabinet Base for JBC-50-HC	5	AA201	Evaporator Fan Motor Cover for JBC-50-HC	22	AA247	Condenser Fan Motor for JBC-50-HC	39
AA222	Door for JBC-50-HC	6	AA128	Evaporator Fan Motor for JBC-50-HC	23	AA248	Condenser Fan Blade for JBC-50-HC	40
AA191	Door Handle for JBC-50-HC	7	AA236	Inner Drain Pan for JBC-50-HC	24	AA249	Condenser Fan Motor Cover for JBC-50-HC	41
AA223	Door Gasket for JBC-50-HC	8	AA237	Cabinet for JBC-50-HC	25	AA130	Filter for JBC-50-HC	42
AA224	Door Limit Block for JBC-50-HC	9	AA238	Right Support for Evaporator Cover for JBC-50-HC	26	AA129	Filter Fixer for JBC-50-HC	43
AA225	Shelf for JBC-50-HC	10	AA192	Back Limit Block for JBC-50-HC	27	AA216	Drain Tube for JBC-50-HC	44
AA226	Shelf Spring for JBC-50-HC	11	AA239	Back Grill for JBC-50-HC	28	AA250	Condenser for JBC-50-HC	45
AA227	Shelf Cap for JBC-50-HC	12	AA240	Inner Baffle for JBC-50-HC	29	AA251	Outer Drain Pan for JBC-50-HC	46
AA228	Panel Under Table for JBC-50-HC	13	AA241	Thermostat Installation Cover for JBC-50-HC	30	AA252	Power Cord for JBC-50-HC	47
AA229	Under Table Component for JBC-50-HC	14	AA123	Thermostat for JBC-50-HC	31	AA196	Key for JBC-50-HC	48
AA197	Lock for JBC-50-HC	15	AA124	Power Switch for JBC-50-HC	32	AA214	Thermostat Water Proof Cover for JBC-50-HC	49
AA230	Base Board for Lock for JBC-50-HC	16	AA242	Evaporator for JBC-50-HC	33	AA253	Thermostat Baffle for JBC-50-HC	50
AA231	Decoration Cover for JBC-50-HC	17	AA243	Screw for Bottle Opener Component for JBC-50-HC	34			

Parts Breakdown

Model BB-CN-0017-HC 50040

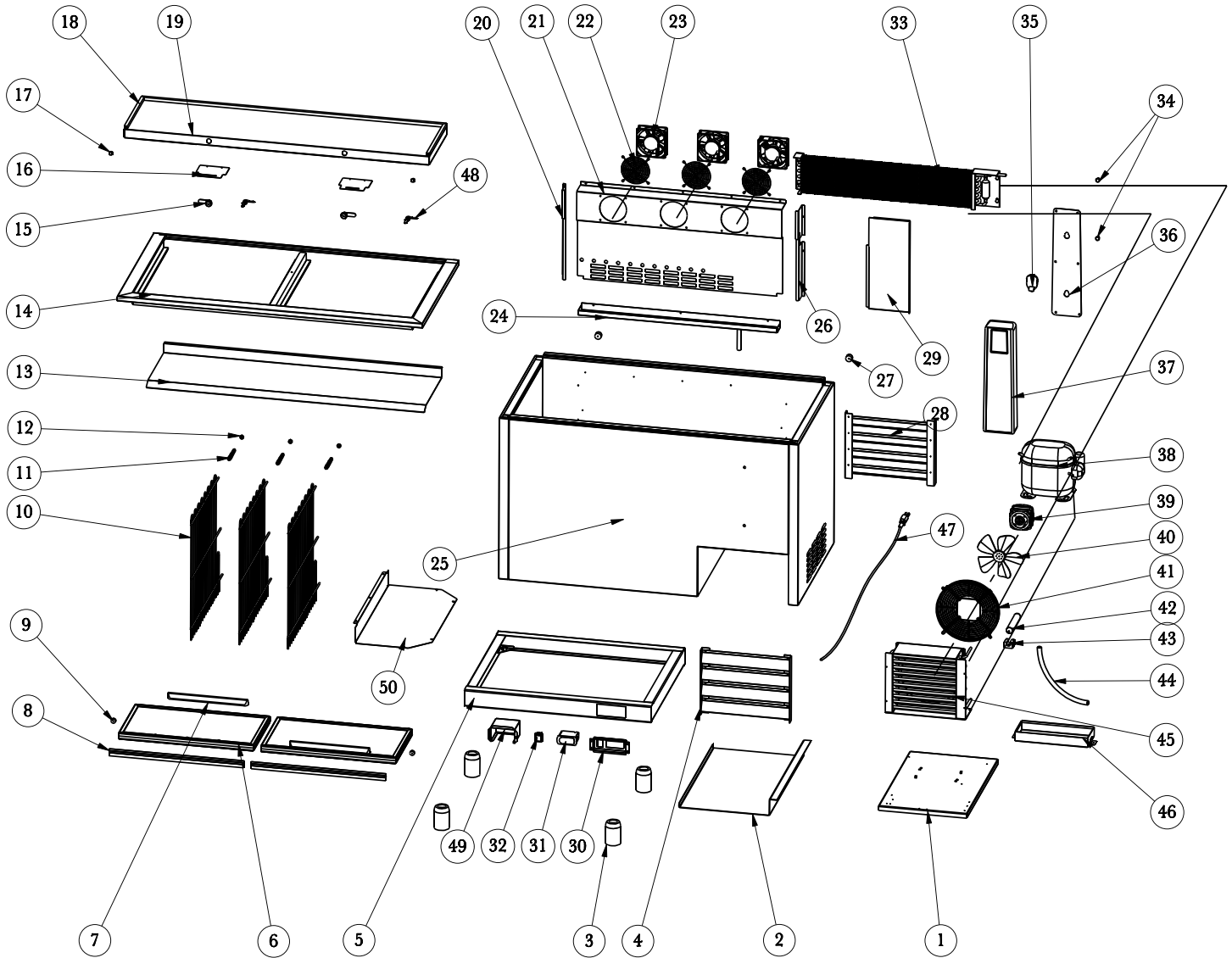

Parts Breakdown

Model BB-CN-0017-HC 50040

Item No.	Description	Position	Item No.	Description	Position	Item No.	Description	Position
AA254	Compressor Unit Installation Board for JBC-65-HC	1	AA264	Decoration Strip for JBC-65-HC	18	AA244	Bottle Opener for JBC-65-HC	35
AA255	Base Board for JBC-65-HC	2	AA265	Top Board for JBC-65-HC	19	AA275	Bottle Opener Board for JBC-65-HC	36
AA185	Leveling Feet for JBC-65-HC	3	AA266	Left Support for Evaporator Cover for JBC-65-HC	20	AA246	Bottle Opener Cover for JBC-65-HC	37
AA256	Front Grill for JBC-65-HC	4	AA267	Evaporator Cover for JBC-65-HC	21	64172	Compressor for JBC-65-HC	38
AA257	Cabinet Base for JBC-65-HC	5	AA201	Evaporator Fan Motor Cover for JBC-65-HC	22	AA247	Condenser Fan Motor for JBC-65-HC	39
AA258	Door for JBC-65-HC	6	AA128	Evaporator Fan Motor for JBC-65-HC	23	AA248	Condenser Fan Blade for JBC-65-HC	40
AA191	Door Handle for JBC-65-HC	7	AA268	Inner Drain Pan for JBC-65-HC	24	AA249	Condenser Fan Motor Cover for JBC-65-HC	41
AA259	Door Gasket for JBC-65-HC	8	AA269	Cabinet for JBC-65-HC	25	AA130	Filter for JBC-65-HC	42
AA260	Door Limit Block for JBC-65-HC	9	AA270	Right Support for Evaporator Cover for JBC-65-HC	26	AA129	Filter Fixer for JBC-65-HC	43
AA225	Shelf for JBC-65-HC	10	AA192	Back Limit Block for JBC-65-HC	27	AA216	Drain Tube for JBC-65-HC	44
AA226	Shelf Spring for JBC-65-HC	11	AA271	Back Grill for JBC-65-HC	28	AA250	Condenser for JBC-65-HC	45
AA227	Shelf Cap for JBC-65-HC	12	AA272	Inner Baffle for JBC-65-HC	29	AA276	Outer Drain Pan for JBC-65-HC	46
AA261	Panel Under Table for JBC-65-HC	13	AA273	Thermostat Installation Cover for JBC-65-HC	30	AA252	Power Cord for JBC-65-HC	47
AA262	Under Table Component for JBC-65-HC	14	AA123	Thermostat for JBC-65-HC	31	AA196	Key for JBC-65-HC	48
AA197	Lock for JBC-65-HC	15	AA124	Power Switch for JBC-65-HC	32	AA214	Thermostat Water Proof Cover for JBC-65-HC	49
AA263	Base Board for Lock for JBC-65-HC	16	AA274	Evaporator for JBC-65-HC	33	AA277	Thermostat Baffle for JBC-65-HC	50
AA231	Decoration Cover for JBC-65-HC	17	AA243	Screw for Bottle Opener Component for JBC-65-HC	34			

Parts Breakdown

Model BB-CN-0026-HC 50041

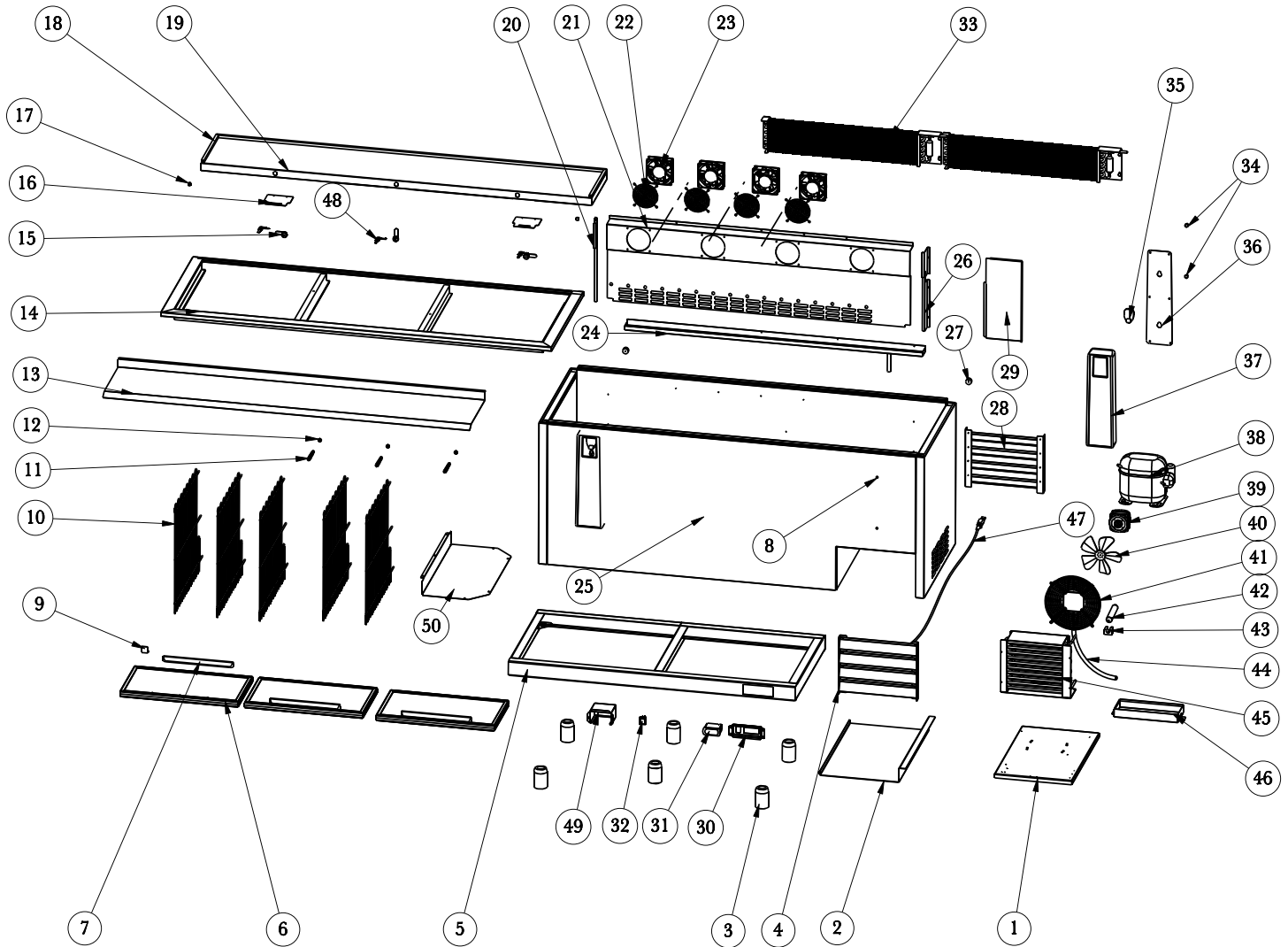

Parts Breakdown

Model BB-CN-0026-HC 50041

Item No.	Description	Position	Item No.	Description	Position	Item No.	Description	Position
AA278	Compressor Unit Installation Board for JBC-95-HC	1	AA288	Decoration Strip for JBC-95-HC	18	AA244	Bottle Opener for JBC-95-HC	35
AA279	Base Board for JBC-95-HC	2	AA289	Top Board for JBC-95-HC	19	AA299	Bottle Opener Board for JBC-95-HC	36
AA185	Leveling Feet for JBC-95-HC	3	AA290	Left Support For Evaporator Cover for JBC-95-HC	20	AA246	Bottle Opener Cover for JBC-95-HC	37
AA280	Front Grill for JBC-95-HC	4	AA291	Evaporator Cover for JBC-95-HC	21	64168	Compressor for JBC-95-HC	38
AA281	Cabinet Base for JBC-95-HC	5	AA201	Evaporator Fan Motor Cover for JBC-95-HC	22	AA247	Condenser Fan Motor for JBC-95-HC	39
AA282	Door for JBC-95-HC	6	AA128	Evaporator Fan Motor for JBC-95-HC	23	AA248	Condenser Fan Blade for JBC-95-HC	40
AA191	Door Handle for JBC-95-HC	7	AA292	Inner Drain Pan for JBC-95-HC	24	AA249	Condenser Fan Motor Cover for JBC-95-HC	41
AA283	Door Gasket for JBC-95-HC	8	AA293	Cabinet for JBC-95-HC	25	AA130	Filter for JBC-95-HC	42
AA284	Door Limit Block for JBC-95-HC	9	AA294	Right Support for Evaporator Cover for JBC-95-HC	26	AA129	Filter Fixer for JBC-95-HC	43
AA225	Shelf for JBC-95-HC	10	AA192	Back Limit Block for JBC-95-HC	27	AA216	Drain Tube for JBC-95-HC	44
AA226	Shelf Spring for JBC-95-HC	11	AA295	Back Grill for JBC-95-HC	28	AA300	Condenser for JBC-95-HC	45
AA227	Shelf Cap for JBC-95-HC	12	AA296	Inner Baffle for JBC-95-HC	29	AA301	Outer Drain Pan for JBC-95-HC	46
AA285	Panel Under Table for JBC-95-HC	13	AA297	Thermostat Installation Cover for JBC-95-HC	30	AA252	Power Cord for JBC-95-HC	47
AA286	Under Table Component for JBC-95-HC	14	AA123	Thermostat for JBC-95-HC	31	AA196	Key for JBC-95-HC	48
AA197	Lock for JBC-95-HC	15	AA124	Power Switch for JBC-95-HC	32	AA214	Thermostat Water Proof Cover for JBC-95-HC	49
AA287	Base Board for Lock for JBC-95-HC	16	AA298	Evaporator for JBC-95-HC	33	AA302	Thermostat Baffle for JBC-95-HC	50
AA231	Decoration Cover for JBC-95-HC	17	AA243	Screw for Bottle Opener Component for JBC-95-HC	34			

Electrical Schematics

Model **BB-CN-0005-HC** 50038

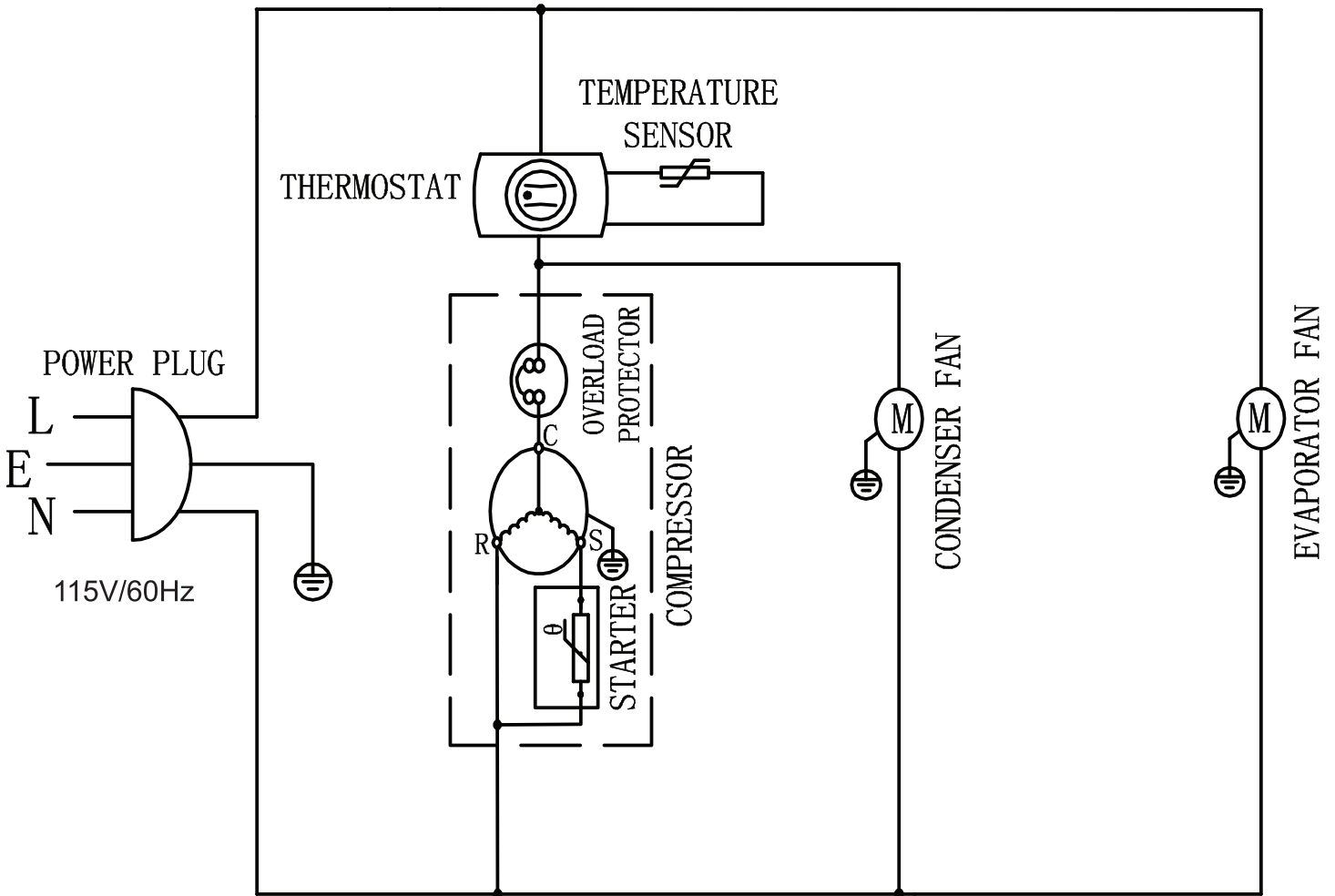

Electrical Schematics

Model BB-CN-0014-HC 50039

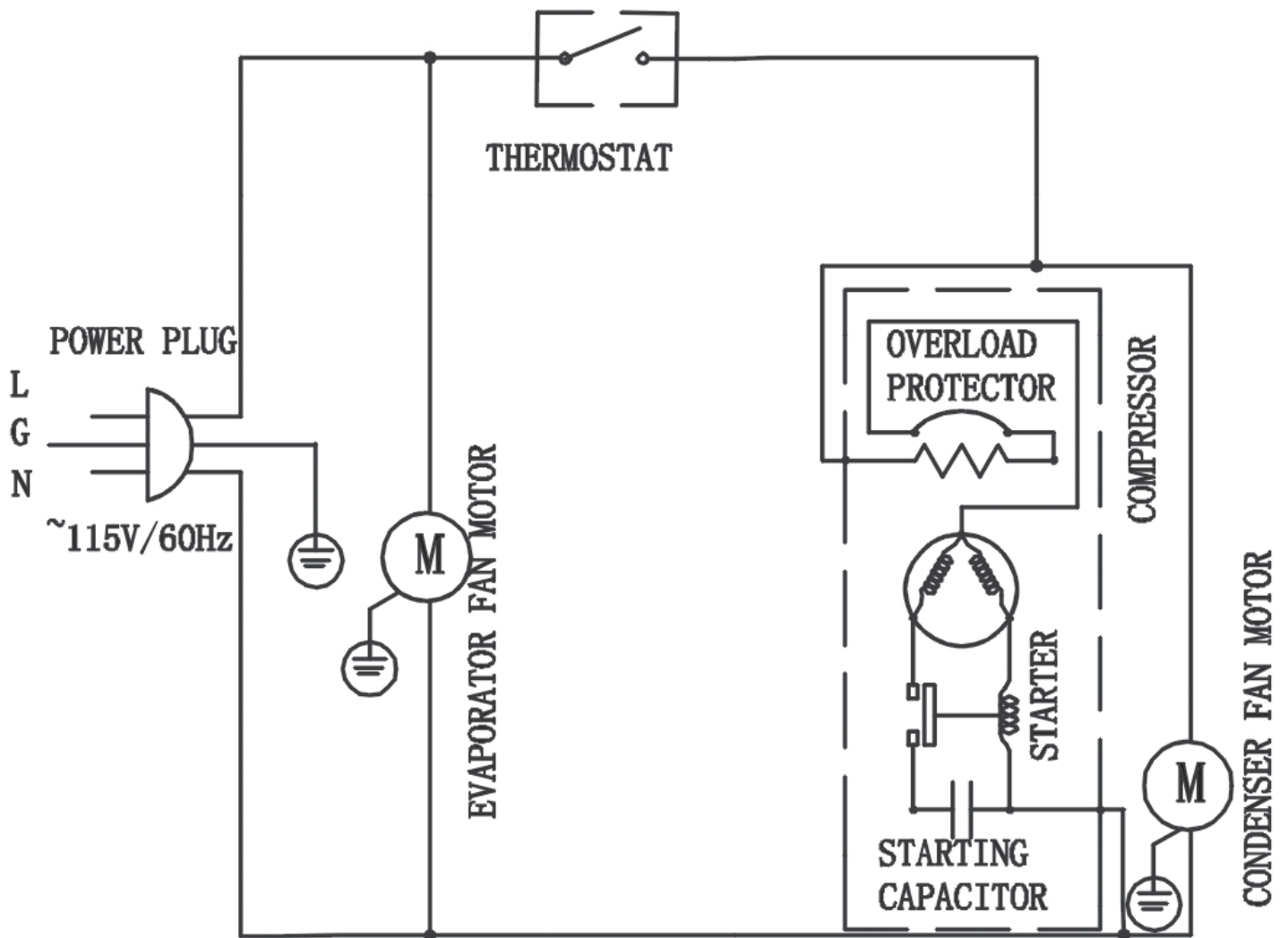

Electrical Schematics

Model BB-CN-0017-HC 50040

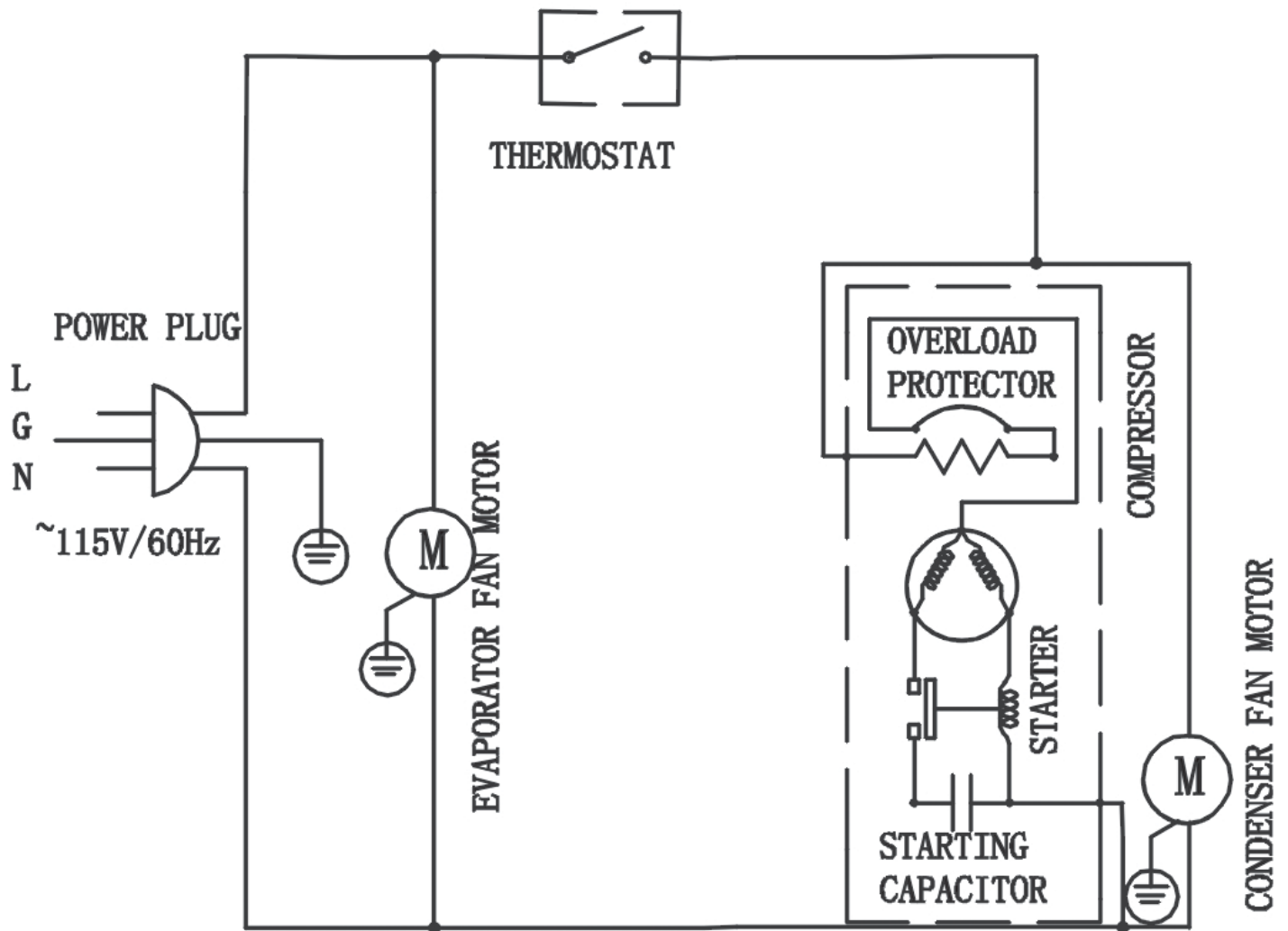

Electrical Schematics

Model **BB-CN-0026-HC** 50041

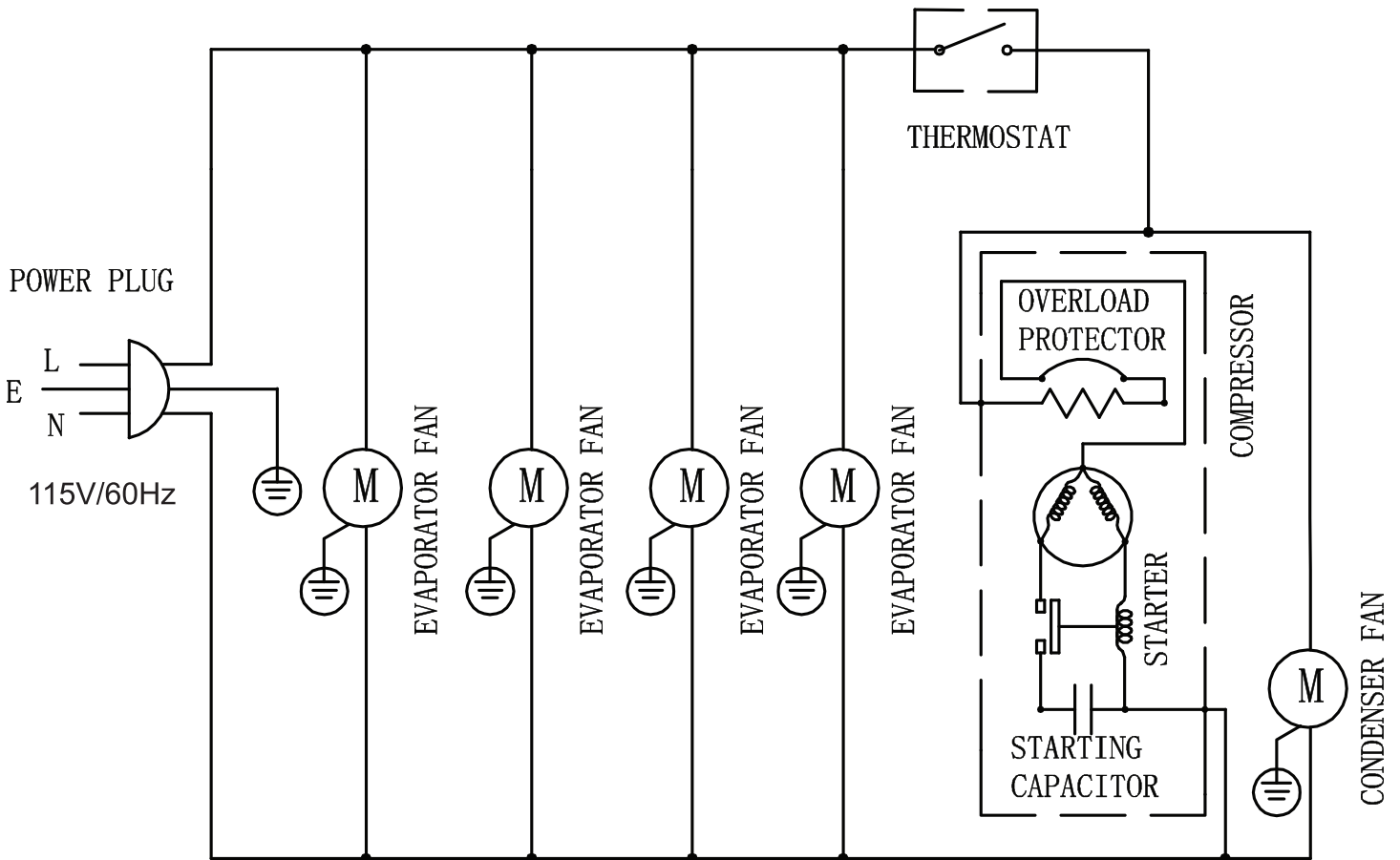



Warranty Registration

Thank you for purchasing an Omcan product. To register your warranty for this product, complete the information below, tear off the card at the perforation and then send to the address specified below. You can also register online by visiting:

Merci d'avoir acheté un produit Omcan. Pour enregistrer votre garantie pour ce produit, complétez les informations ci-dessous, détachez la carte au niveau de la perforation, puis l'envoyer à l'adresse spécifiée ci-dessous. Vous pouvez également vous inscrire en ligne en visitant:

Gracias por comprar un producto Omcan usted. Para registrar su garantía para este producto, complete la información a continuación, cortar la tarjeta en la perforación y luego enviarlo a la dirección indicada a continuación. También puede registrarse en línea en:

<https://omcan.com/warranty-registration/>

For mailing in Canada

Pour postale au Canada

Por correo en Canadá

OMCAN

PRODUCT WARRANTY REGISTRATION

3115 Pepper Mill Court,

Mississauga, Ontario

Canada, L5L 4X5

For mailing in the US

Pour diffusion aux États-Unis

Por correo en los EE.UU.

OMCAN

PRODUCT WARRANTY REGISTRATION

4450 Witmer Industrial Estates, Unit 4,

Niagara Falls, New York

USA, 14305

or email to: service@omcan.com



Purchaser's Information

Name: _____

Address: _____

City: _____ Province or State: _____ Postal or Zip: _____

Country: _____

Dealer from which Purchased: _____

Dealer City: _____ Dealer Province or State: _____

Invoice: _____

Model Name: _____ Model Number: _____

Machine Description: _____

Date of Purchase (MM/DD/YYYY): _____

Would you like to extend the warranty? Yes No

Company Name: _____

Telephone: _____

Email Address: _____

Type of Company:

Restaurant Bakery Deli

Butcher Supermarket Caterer

Institution (*specify*): _____

Other (*specify*): _____

Serial Number: _____

Date of Installation (MM/DD/YYYY): _____

Thank you for choosing Omcan | Merci d'avoir choisi Omcan | Gracias por elegir Omcan



Since 1951 Omcan has grown to become a leading distributor of equipment and supplies to the North American food service industry. Our success over these many years can be attributed to our commitment to strengthen and develop new and existing relationships with our valued customers and manufacturers. Today with partners in North America, Europe, Asia and South America, we continually work to improve and grow the company. We strive to offer customers exceptional value through our qualified local sales and service representatives who provide convenient access to over 5,000 globally sourced products.

Depuis 1951 Omcan a grandi pour devenir un des “leaders” de la distribution des équipements et matériel pour l’industrie des services alimentaires en Amérique du Nord. Notre succès au cours de ces nombreuses années peut être attribué à notre engagement à renforcer et à développer de nouvelles et existantes relations avec nos clients et les fabricants de valeur. Aujourd’hui avec des partenaires en Amérique du Nord, Europe, Asie et Amérique du Sud, nous travaillons continuellement à améliorer et développer l’entreprise. Nous nous efforçons d’offrir à nos clients une valeur exceptionnelle grâce à nos ventes locales qualifiées et des représentants de service qui offrent un accès facile à plus de 5000 produits provenant du monde entier.

Desde 1951 Omcan ha crecido hasta convertirse en un líder en la distribución de equipos y suministros de alimentos en América del Norte industria de servicios. Nuestro éxito en estos años se puede atribuir a nuestro compromiso de fortalecer y desarrollar nuevas relaciones existentes con nuestros valiosos clientes y fabricantes. Hoy con socios de América del Norte, Europa, Asia y América del Sur, que trabajan continuamente para mejorar y crecer la empresa. Nos esforzamos por ofrecer a nuestros clientes valor excepcional a través de nuestro local de ventas y representantes de los servicios que proporcionan un fácil acceso a más de 5,000 productos con origen a nivel mundial.

