

English User Manual

Table Top Type Dough Sheeter



CONTENTS

Chapter 1	Product Introduction	1
Chapter 2	Installation Instructions	2
Chapter 3	Technical Parameter	3
Chapter 4	Principle Description	4
Chapter 5	Circuit Principle	5
Chapter 6	Operation Instructions	6
Chapter 7	Trouble & Maintenance	7
Chapter 8	Daily Care	8

Chapter 1 Product Introduction

1. Flexible adjustment of thickness and spreading equally.
2. Two way transmission, two speed.
3. Folding structure, save space.
4. Roller: made of seamless steel pipe, computer lathe processed, grinded, hard chromium plated and etc.

Roller surface: not adhesive, not easy to scratch.

5. Conveyor Belt: wear resistance.
6. Imported motor accessories: increased the service time.
7. Easy operation, high efficient.
8. Suitable for crisp food and spreading dough.

Chapter 2 Installation Instructions

1. The machine should be placed on the flat table surface, then adjust the 4 foot stand to fix the machine, preventing movement when the machine working.
2. When put the machine beside the wall, remember to make the distance more than 300mm between the wall and machine.
3. When connecting wire, please comply with the requirements of electrical safety regulations.
4. Connecting wire way:
 - ① Three-phase: The cable is marked with U.V.W line, respectively connect to the three-phase power line.(Before connecting the machine, make sure the power supply must have configured leakage circuit breaker.)
 - ② Single-phase: The cable is marked with N line, connect to the single-phase zero line. The cable is marked with L line, connect to the single-phase power line. (Before connecting the machine, make sure the power supply must have configured leakage circuit breaker.)
5. Connecting ground wire: The cable core of the machine has been equipped with special yellow green ground wire, the machine also has the grounding terminal symbol \perp , connect the grounding terminal symbol to the ground wire of the power supply.

Chapter 3 Technical Parameter

(1) Model: JDR-450B

Product Name: Table top type dough sheeter
Machine Size: 1770x820x620mm (LxWxH)
Working Position Length/Height: 1770/620mm
Resting Position Length/Height: 750/710mm
Conveyor Belt Size: 1700x430mm (LxW)
Roller Adjustable gap: 1~40mm
Voltage: 380V/50HZ/3PH
 220V/50HZ/1PH
Power: 380V~0.55KW
 220V~0.56KW
Maximum Roll Weight: 4KG
Net Weight: 117KG

(2) Model: JDR-520B

Product Name: Table top type dough sheeter
Machine Size: 2080x880x620mm (LxWxH)
Working Position Length/Height: 2080/620mm
Resting Position Length/Height: 750/840mm
Conveyor Belt Size: 2000x500mm (LxW)
Roller Adjustable gap: 1~40mm
Voltage: 380V/50HZ/3PH
 220V/50HZ/1PH
Power: 380V~0.55KW
 220V~0.56KW
Maximum Roll Weight: 5KG
Net Weight: 125KG

Chapter 4 Principle Description

(1) The gear motor transmits the power to the upper and lower roller through the sprocket, meanwhile transmits the power to the conveyor belt roller through the reversing gear set. The upper and lower roller are used for spreading dough. The upper roller can adjust the thickness of the dough through the eccentric cam. Both the upper and lower roller have the scraper joint, to strike off the residual dough on the roller surface. Both end side of the machine have the screw which can adjust the tightness of the conveyor belt.

(2) Safety Attentions:

- ① When the machine failure, please cut off the power first, and ask the qualified professional electrician to repair. Repairing the machine with power is strictly prohibited!
- ② **Warning!** The machine can not be cleaned by water flow directly, to prevent leakage of electricity. Use the wet cloth to wipe the machine.
- ③ For those people who with physical, sensory or mental defects, or lack of experience and knowledge(including children), this user manual is not suitable for use.

Chapter 5 Circuit Principle

**Table Type Dough Sheeter
(Single Phase)**

Power Input

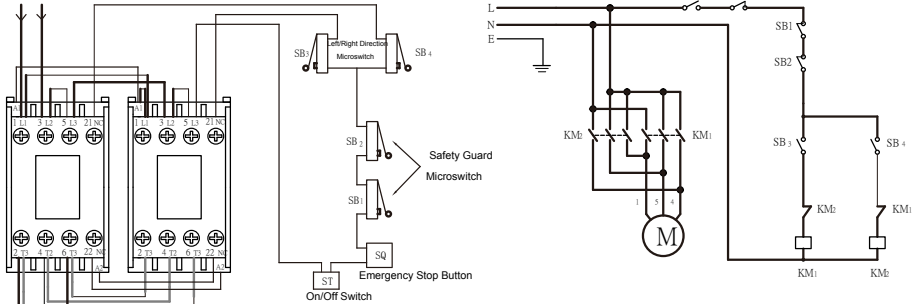

E:Ground Wire

SQ:Emergency Stop Button

ST:On/Off Switch

Motor

L,N:Power Input

SB1, SB2:Safety Guard Microswitch
(Normally Closed)

KM1, KM2: AC Contactor

M:Motor

SB3, SB4:Left/Right Direction Microswitch
(Normally open)

**Table Type Dough Sheeter
(Three Phase)**

Power Input

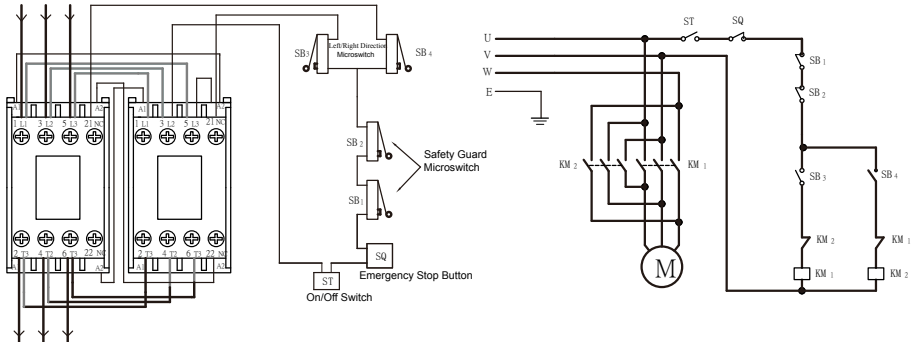

E:Ground Wire

SQ:Emergency Stop Button

ST:On/Off Switch

Motor

L,N:Power Input

SB1, SB2:Safety Guard Microswitch
(Normally Closed)

KM1, KM2: AC Contactor

M: Motor

SB3, SB4:Left/Right Direction Microswitch
(Normally Open)

Chapter 6 Operation Instructions

Before starting the machine, check whether there are anything or other factors to interfere with the machine operation or not. Be sure to work without obstruction. When adjust the thickness of dough, the graduation should not exceed 8mm each time it is operated.

After using the machine, check whether there has residual dough on the roller surface or not. Keep the conveyor belt clean.

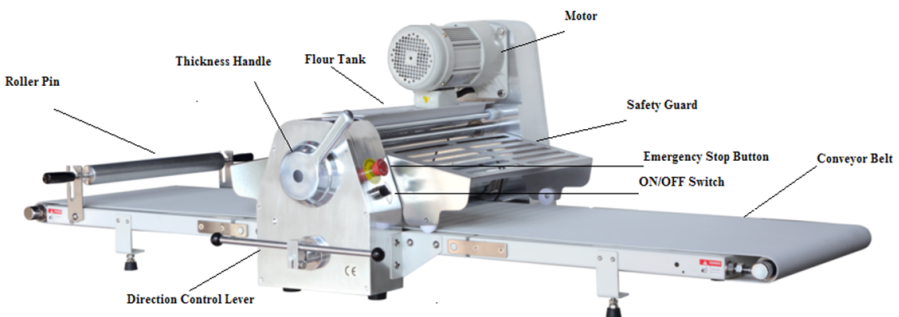

Chapter 7 Trouble & Maintenance

1、 Machine can not work:

①Check power supply is on or not.

Check Power switch is on?

②Check safety guard has been put down or not.

③Check direction control lever is in place or not.

2、 Machine has big noise:

①Check all parts of lubrication is good or not

②Check transmission chain is too loose or not

③Check all bearing is good or not.

3、 Conveyor running outside:

①Check there has anything between conveyor belt and roller or not.

②Adjust the both end side of the screw.

Chapter 8 Daily Care

After working is finished every day, please turn the power switch off, then do the cleaning as below:

- 1、 Fold the conveyor belt plate, then clean the residual dough and sundries which left on the conveyor belt roller.
- 2、 Clean the residual dough which left on the upper and lower roller and scraper. Make sure that there is nothing left on the roller and scraper.

Attentions : Don't use knife and hard thing to scrape the roller. Use the wet cloth to wipe.

Don't use the stainless steel and other metal blade to scrape the conveyor belt surface. Use the plastic scraper to clean the conveyor belt surface.

