



***High Temp Dishwasher***  
***Model CD-GR-0500***  
***Item 46320***  
***Instruction Manual***



*Revised - 01/09/2020*



---

Toll Free: 1-800-465-0234  
Fax: 905-607-0234  
Email: [service@omcan.com](mailto:service@omcan.com)  
[www.omcan.com](http://www.omcan.com)



# ***Table of Contents***

Model CD-GR-0500

---

<b>Section</b>	<b>Page</b>
General Information -----	3 - 4
Technical Specifications -----	5 - 7
Safety and Warranty -----	8 - 9
Installation -----	10 - 17
Operation -----	17 - 19
Maintenance -----	20 - 21
Troubleshooting -----	22 - 23
Parts Breakdown -----	24 - 41
Electrical Schematics -----	42
Notes -----	43 - 45
Installation Requirements and Checklist -----	46
Warranty Registration -----	47



# General Information

---

Omcan Manufacturing and Distributing Company Inc., Food Machinery of America, Inc. dba Omcan and Omcan Inc. are not responsible for any harm or injury caused due to any person's improper or negligent use of this equipment. The product shall only be operated by someone over the age of 18, of sound mind, and not under the influence of any drugs or alcohol, who has been trained in the correct operation of this machine, and is wearing authorized, proper safety clothing. Any modification to the machine voids any warranty, and may cause harm to individuals using the machine or in the vicinity of the machine while in operation.

## CHECK PACKAGE UPON ARRIVAL

Upon receipt of an Omcan shipment please inspect for external damage. If no damage is evident on the external packaging, open carton to ensure all ordered items are within the box, and there is no concealed damage to the machine. If the package has suffered rough handling, bumps or damage (visible or concealed), please note it on the bill of lading before accepting the delivery and contact Omcan within 24 hours, so we may initiate a claim with the carrier. A detailed report on the extent of the damage caused to the machine must be filled out within three days, from the delivery date shown in the shipping documents. Omcan has no recourse for damaged products that were shipped collect or third party.

**Before operating any equipment, always read and familiarize yourself with all operation and safety instructions.**

Omcan would like to thank you for purchasing this machine. It's of the utmost importance to save these instructions for future reference. Also save the original box and packaging for shipping the equipment if servicing or returning of the machine is required.

---

Omcan Fabrication et distribution Compañie Limité et Food Machinery d'Amérique, dba Omcan et Omcan Inc. ne sont pas responsables de tout dommage ou blessure causé du fait que toute personne ait utilisé cet équipement de façon irrégulière. Le produit ne doit être exploité que par quelqu'un de plus de 18 ans, saine d'esprit, et pas sous l'influence d'une drogue ou d'alcool, qui a été formé pour utiliser cette machine correctement, et est vêtu de vêtements de sécurité approprié. Toute modification de la machine annule toute garantie, et peut causer un préjudice à des personnes utilisant la machine ou des personnes à proximité de la machine pendant son fonctionnement.

## VÉRIFIEZ LE COLIS DÈS RÉCEPTION

Dès réception d'une expédition d'Omcan veuillez inspecter pour dommages externes. Si aucun dommage n'est visible sur l'emballage externe, ouvrez le carton afin de s'assurer que tous les éléments commandés sont dans la boîte, et il n'y a aucun dommage dissimulé à la machine. Si le colis n'a subi aucune mauvaises manipulations, de bosses ou de dommages (visible ou cachée), notez-le sur le bond de livraison avant d'accepter la livraison et contactez Omcan dans les 24 heures qui suivent, pour que nous puissions engager une réclamation auprès du transporteur. Un rapport détaillé sur l'étendue des dommages causés à la machine doit être rempli dans un délai de trois jours, à compter de la date de livraison indiquée dans les documents d'expédition. Omcan n'a aucun droit de recours pour les produits endommagés qui ont été expédiés ou cueilli par un tiers transporteur.

# **General Information**

---

**Avant d'utiliser n'importe quel équipement, toujours lire et vous familiariser avec toutes les opérations et les consignes de sécurité.**

**Omcan voudrais vous remercier d'avoir choisi cette machine. Il est primordial de conserver ces instructions pour une référence ultérieure. Également conservez la boîte originale et l'emballage pour l'expédition de l'équipement si l'entretien ou le retour de la machine est nécessaire.**

---

**Omcan Empresa De Fabricacion Y Distribucion Inc. Y Maquinaria De Alimentos De America, Inc. dba Omcan y Omcan Inc. no son responsables de ningun daño o perjuicio causado por cualquier persona inadecuada o el uso descuidado de este equipo. El producto solo podra ser operado por una persona mayor de 18 años, en su sano juicio y no bajo alguna influencia de droga o alcohol, y que este ha sido entrenado en el correcto funcionamiento de esta máquina, y ésta usando ropa apropiada y autorizada. Cualquier modificación a la máquina anula la garantía y puede causar daños a las personas usando la máquina mientras esta en el funcionamiento.**

## **REVISE EL PAQUETE A SU LLEGADA**

**Tras la recepcion de un envio Omcan favor inspeccionar daños externos. Si no hay daños evidentes en el empaque exterior, Habra el carton para asegurarse que todos los articulos solicitados estén dentro de la caja y no encuentre daños ocultos en la máquina. Si el paquete ha sufrido un manejo de poco cuidado, golpes o daños (visible o oculto) por favor anote en la factura antes de aceptar la entrega y contacte Omcan dentro de las 24 horas, de modo que podamos iniciar una reclamación con la compañía. Un informe detallado sobre los daños causados a la máquina debe ser llenado en el plazo de tres días, desde la fecha de entrega que se muestra en los documentos de envío. Omcan no tiene ningun recurso por productos dañados que se enviaron a recoger por terceros.**

**Antes de utilizar cualquier equipo, siempre lea y familiarizarse con todas las instrucciones de funcionamiento y seguridad.**

**Omcan le gustaría darle las gracias por la compra de esta máquina. Es de la mayor importancia para salvar estas instrucciones para futuras consultas. Además, guarda la caja original y el embalaje para el envío del equipo si servicio técnico o devolución de la máquina que se requiere.**



# Technical Specifications

<b>Model</b>	<b>CD-GR-0500</b>
<b>Voltage</b>	220-240V 60Hz
<b>Max Power</b>	3.8 Kw
<b>Max Amperes</b>	16 A
<b>Minimum Inlet Water Temperature</b>	40°C / 104°F
<b>Rinse Flow Pressure</b>	20 psi ± 5
<b>Boiler Heating Element</b>	3.1 kW
<b>Tank Heating Element</b>	2.9 kW
<b>Boiler Capacity</b>	6 L
<b>Tank Capacity</b>	35 L
<b>Washing Pump Power</b>	0.75 HP
<b>Overall Dimensions</b>	22.4" x 23.6" x 32.7" / 570 x 600 x 830mm
<b>Basket Dimensions</b>	19.7" x 19.7" / 500 x 500mm
<b>Washing Cycles</b>	104 / 163 / 223 sec.
<b>Rinse Cycle</b>	16 sec.
<b>Peristaltic Detergent Pump</b>	Standard
<b>Peristaltic Rinse Aid Pump</b>	Standard
<b>Boiler Thermofuse</b>	105°C / 221°F
<b>Tank Thermofuse</b>	99°C / 210.2°F
<b>Boiler Thermometer</b>	Standard
<b>Tank Thermometer</b>	Standard
<b>Pressure Gauge</b>	Standard
<b>Door Clearance</b>	14.2" / 360mm
<b>Max Glass</b>	12.8" / 325mm
<b>Max Dish</b>	13.2" / 335mm
<b>Net Weight</b>	121.25 lbs. / 55 kgs.
<b>Gross Weight</b>	132.3 lbs. / 60 kgs.
<b>Item Number</b>	46320

# ***Technical Specifications***

---

**ELVIOMEX**  
PROFESSIONAL WIRE WELDING MACHINES

**ALFA** ELVIOMEX s.a.

---

**Model : CD-GR-0500**

Wash Time (Sec) :

103 / 163 / 223

Minimum Wash

Rinse Time

Temp. : 165 oF (74 oC)

(Sec) : 16

Minimum Rinse

Inlet Water

Temp. : 165 oF (74 oC)

Pressure : 138 ± 34 kPa

(20 ± 5 psi)



# *Technical Specifications*

---

PRODUCT SERIAL NUMBER

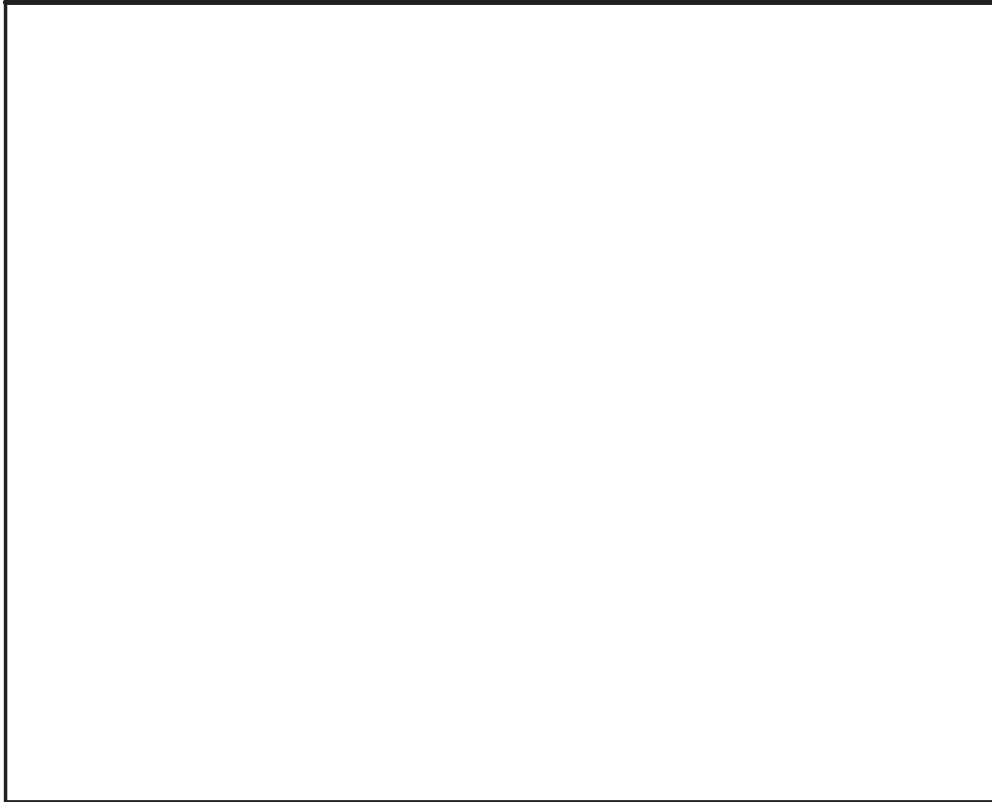
A large, empty rectangular box with a thin black border, intended for the user to enter the product serial number.

# Safety and Warranty

---

THE FOLLOWING SYMBOLS INDICATE IMPORTANT INFORMATION THROUGHOUT THIS MANUAL.



Caution symbols indicate action or condition that can result in damage to the machine.



Not approved symbols indicate action or condition that will diminish the optimum operation of the machine.



Approved symbols indicate action or condition that is safe and correct and should be followed.



Warning symbols indicate action or condition that can be hazardous.



Note symbols indicate important information that should be followed for installing or operating the machine.

## INDICATIONAL WARNINGS - CAUTIONS - NOTES



Machine installation must comply with all local Health, Plumbing, Electrical and Safety codes.



All Plumbing connections ARE PRIOR to the electrical installations and must be performed by qualified service personnel otherwise there is risk of damages to heating elements.



Problems or Damages caused due to improper installation are not covered by the Limited Warranty.



All debris from the water supply line must be flushed before connecting it to the machine. Debris can damage the machine supply valves.



Handle with care when lifting or moving to avoid damage or leakings.



Plumbing and Electrical connections must allow the machine to move for service or cleaning.



Before any electrical or service operation disconnect the main electrical supply and lock it out in order to clearly indicate that there is work in progress.

# Safety and Warranty

---

1. All pumping connections must be made prior to the electrical connection as otherwise there is high risk of damages to heating elements.  
Damages due to negligence installation are not covered by the warranty.
2. Be careful when lifting or moving the dishwasher to avoid leaks or damages.

Do not use granular detergent. Poor results usually occur.

Do not use caustic products. This will void the guarantee.

Be sure all electrical supply specifications correspond to information label on machine.

The manufacturer/ distributor is not responsible for any possible damages or risks due to improper connection of this appliance.

- I. Inspect the packaging for external damages.
- II. Check that all the following accessories are inside the machine.
  - 1 Glass basket.
  - 1 Dish basket.
  - 1 Cutlery basket.
  - 1 Water inlet hose.
  - 1 Pressure reducer valve (PRV).
  - 4 leveling feet.
  - 4 thread covers for leveling feet.
  - 1 User manual.
  - 1 Extended warranty brochure.

## 1 YEAR PARTS AND LABOUR WARRANTY

Within the warranty period, contact Omcan Inc. at 1-800-465-0234 to schedule an Omcan authorized service technician to repair the equipment locally.

Unauthorized maintenance will void the warranty. Warranty covers electrical and part failures, not improper use.

Please see <https://omcan.com/disclaimer> for complete info.

### WARNING:

The packaging components are classified as normal solid urban waste and can therefore be disposed of without difficulty.

In any case, for suitable recycling, we suggest disposing of the products separately (differentiated waste) according to the current norms.

**DO NOT DISCARD ANY PACKAGING MATERIALS IN THE ENVIRONMENT!**

# Installation

## PLACEMENT

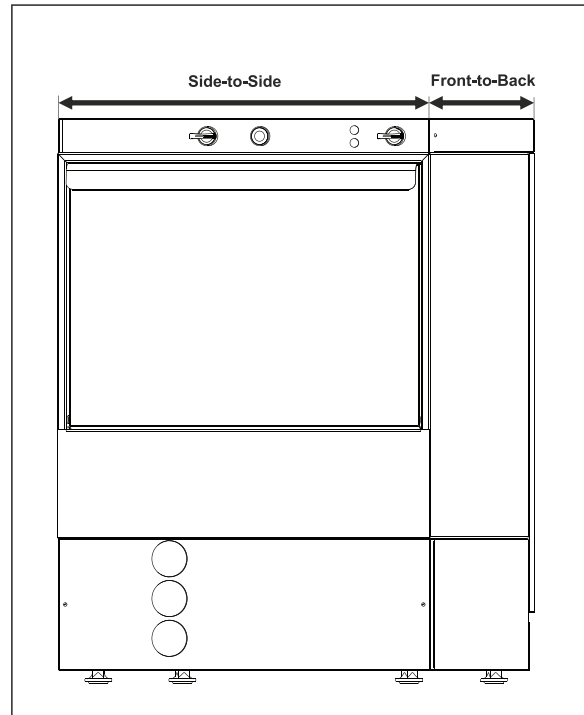

Adjust the legs to level the machine side-to-side and front-to-back

## LEVEL THE MACHINE

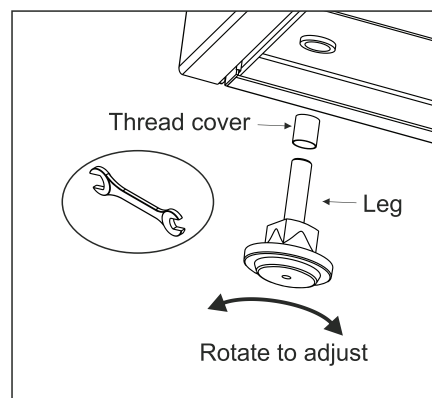

Exploded view leg detail

## INSTALLATION SUGGESTIONS

- Place the dishwasher in the desired location.
- The appliance should be leveled. Adjustable feet are provided for this adjustment.

# Installation

## Note

The leveling feet should not have any exposed threads. Please use the provided bushes in order to cover the exposed threads.

## PLACEMENT - CHEMICAL CONTAINERS

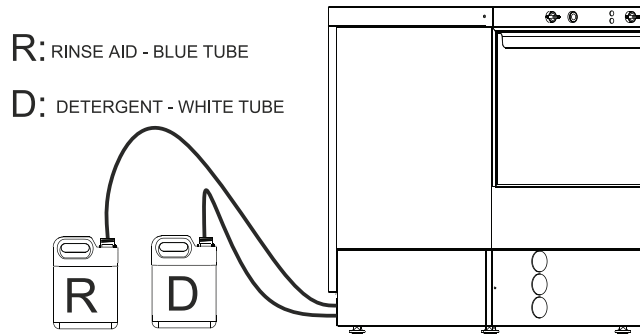

Chemical supply containers must be placed as close as possible to the machine and must not be elevated.



Reposition the chemical tubing at the back of the machine before placing the machine to its permanent position.

The unit should be installed by licensed and approved personnel according to all local codes.

This dishwasher is delivered with water inlet and outlet hoses.

## WATER SUPPLY CONNECTION

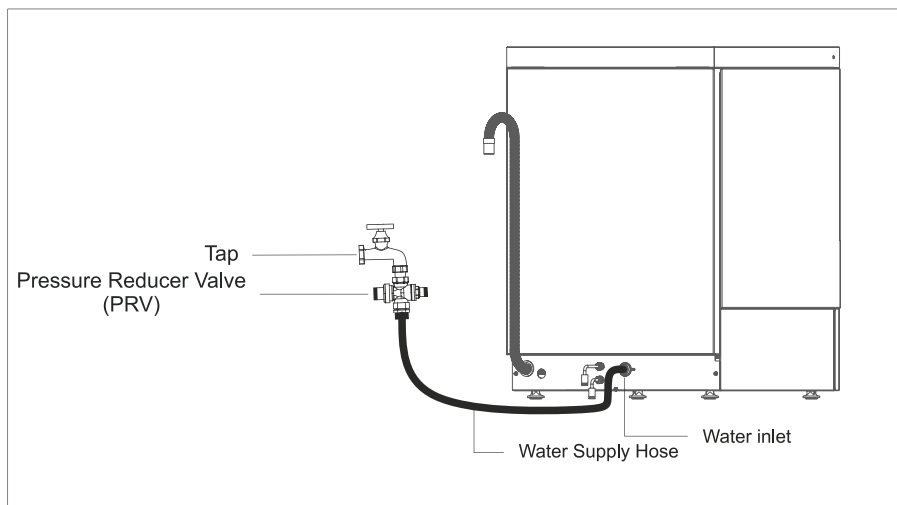

# Installation

**ATTENTION:** Connection with the water supply should be made according to all applicable codes.



Machine must be connected to hot water source. Minimum income water temperature should be 40°.



A Pressure Regulator Valve must be inserted between the machine water inlet and the water source. Water pressure during flow (not static), must be regulated to 20 PSI. During pressure regulation please check the pressure gauge at the front of the machine.

This dishwasher intended for use with a hot water supply but will also operate (at slightly reduced hourly capacity) with a cold water supply.

- The water supply hose/pipe should be OD 14mm x ID 10mm and terminate in a 3/4" NPT fitting (not garden hose).
- The water supply hose/pipe should be flushed before final connection.
- **Minimum flow pressure is 15 PSI and maximum is 25 PSI.**
- Connect hose supplied with machine to the inlet at the rear of the machine and the 3/4" NPT fitting on the water supply line.

## PRESSURE REGULATOR VALVE ADJUSTMENT

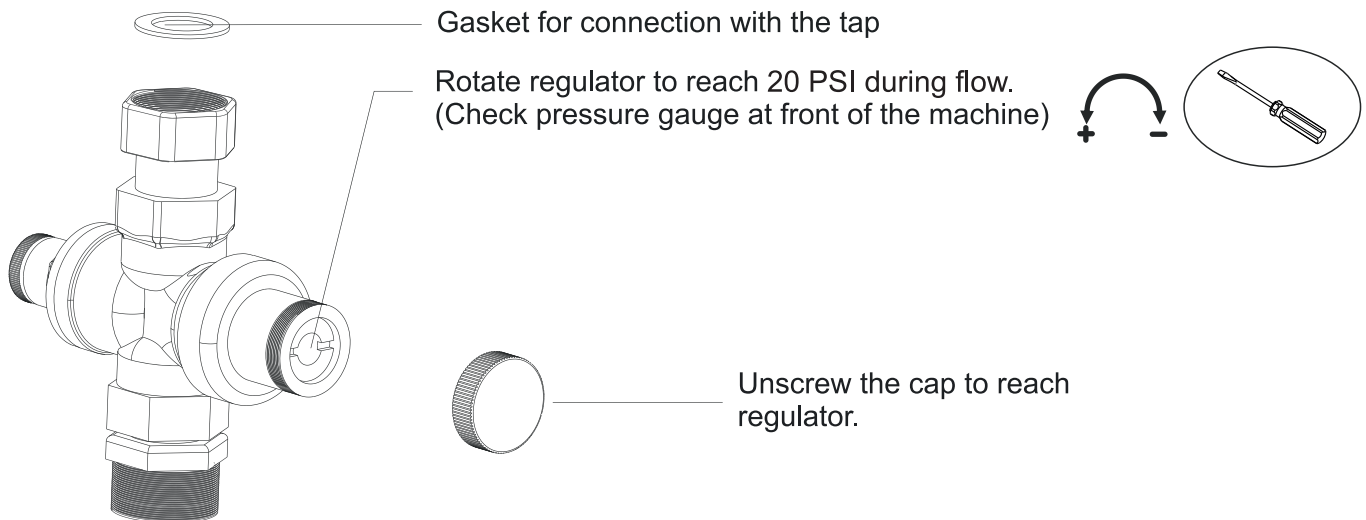

## DRAINAGE CONNECTION

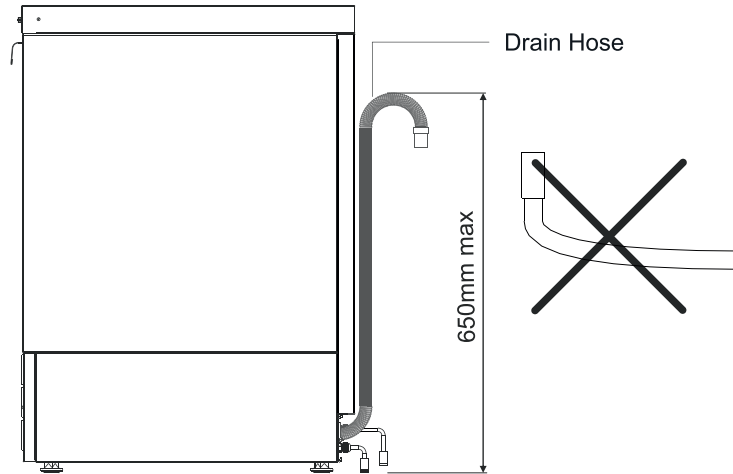

Do not add extension to the drain hose otherwise warranty is void.

Outflow is accomplished by the use of a drain pump in the CD-GR-0500. The outlet hose must not be higher than 650mm from the floor. An open drain connection or one to a vented drain pipe is recommended.

- I. Connect the drain hose to the main draining.
- II. Connection must be made in the same flow with the draining pipe.

### ATTENTION:

- Drain connection to a venting dedicated drain pipe is suggested.
- It is strongly advised NOT to connect the drain hose into the sink's draining.
- If an extension is added to the drain hose the warranty is voided.

### ATTENTION:

- Make sure that no residuals remain to the water supply line before connecting it to the machine.
- Plumbing connections must be made in such way that will allow the machine to be moved for service and cleaning.
- PRV MUST be installed and adjust at 20 PSI otherwise the warranty is voided.

Min water inlet temp.	Operating flow pressure.	Min wash temperature.	Min rinse temperature.
40°C	20 ±5 PSI	165°F / 74°C	165°F / 74°C

- Connect the PRV valve in the water supply shut off valve.
- Connect the water supply hose to the PRV in one side and in the machine on the other side.

**Attention: source water hardness must not intervene 10°F / 6 Gd.**

# Installation

---

## ELECTRICAL CONNECTION

**Attention:** Before make any electrical connection or service, disconnect the main electrical supply and lock it out in order to clearly indicate that there is work in progress.

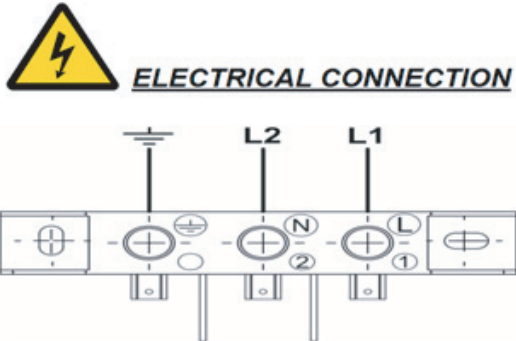

- I. Open the lower front cover (2 bolts).
- II. Open the top cover of electrical circuit.
- III. Connect the cable to the terminal block (Attention: strain relief knockout must be placed by the installer).

**Caution: 15 cm loop of wire must be left inside the machine in order to allow servicing.**

- IV. Replace the top cover.
- V. Replace and secure the lower front cover.

## DETERGENT AND RINSE AID REGULATION.

- I. Open the lower front cover (2 bolts).
- II. Take out the feeders.
- III. Adjust the quantity by regulating the dosing (xxxxxx ml / rotation).
- IV. Replace the feeders.
- V. Make sure that the chemical feeders' hoses are not out of the right position.
- VI. Replace the front lower cover.

## RINSE-AID PUMP

This model has an automatic rinse-aid pump for use with a container of liquid rinse-aid. The rinse-aid pump is a peristaltic regulated (looks exactly like the detergent pump) and can be regulated by a screw above and on the right of the glass cover. The regulation can be from 0 lt/hour to 0,7 lt/hr.

Both pumps are mounting vertically on an inox bracket on the left of the booster and are marked with two yellow stickers.

**Before you perform these adjustments, turn off the power supply.**

**The dozer is adjusted from the manufacturer's premises at its maximum value for easy initial priming and must be adjusted accordingly (depending on water hardness, how dirty the dishes are, and the detergent used).**

To reduce (-) the amount of rinse aid, turn the center screw clockwise. To increase (+), turn counterclockwise.

**Note: this is a 15 revolution adjusting screw to provide fine adjustments as required.**

**Suggestion for initializing personnel:** After priming system by operating machine through several cycles, rotate adjusting screw gently to full closed position (clockwise) and adjust (counter-clockwise) about 7 full revolutions. Empty wash tank and refill with fresh water. Operate for two or three cycles and verify concentration level. Adjust dozer again if required to achieve final desired results.

## ADJUSTMENT OF PERISTALTIC PUMPS

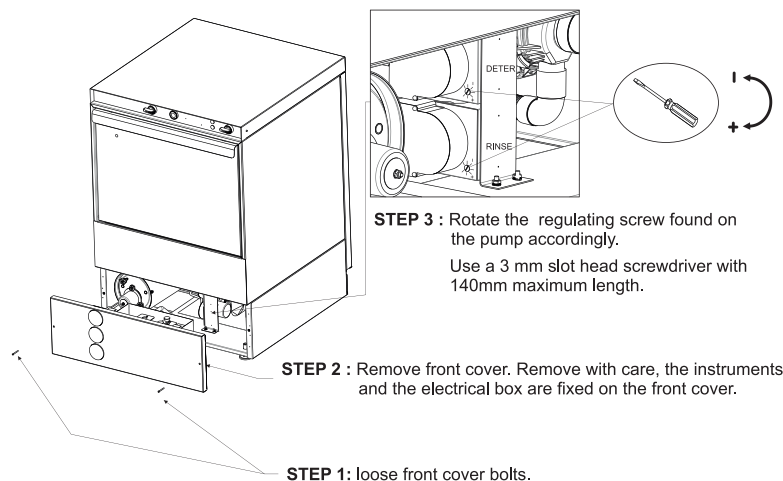

PUMP REGULATION	
DETERGENT	RINSE
2.6ml/rotation	1.2ml/rotation

# Installation

---

## AUTOMATIC FILLING OF DETERGENT

This model has an automatic detergent pump for use with a container of non foaming liquid detergent. The detergent pump is a peristaltic regulated (looks exactly like the rinse-aid pump) and can be regulated by a screw above and on the right of the glass cover. The regulation can be from 0 lt/hour to 3,0 lt/hr.

## MANUAL FILLING OF DETERGENT

Use only non-foaming detergent suitable for commercial dishwashers. In the event of non use or malfunction of the automatic detergent injection system, put the detergent suppliers recommended amount directly into the wash compartment tank after the machine has reached its operating temperature.

The correct dosage depends on the water hardness and the amount of residue on the dishes. Follow the detergent manufacturer's recommendations. Less detergent deters good washing results and more detergent usually does not provide better results, but rather more unnecessary consumption and environment pollution.

## SCREENERS (SURFACE FILTERS) - OVERFLOW PIPE - SUCTION FILTER - DRAIN FILTER

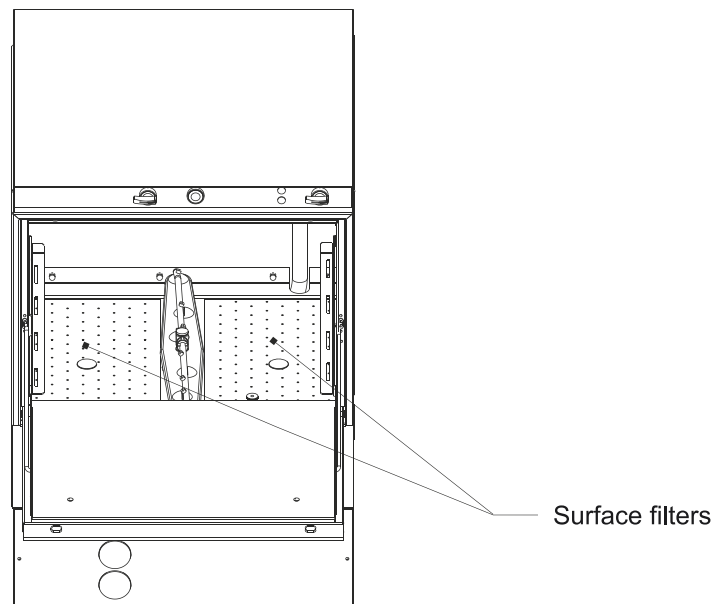

To remove the surface filters first align the rinse and washing arms with the middle filter support and then lift.



Do not remove the surface screeners and internal filters if the tank is not empty

# Installation

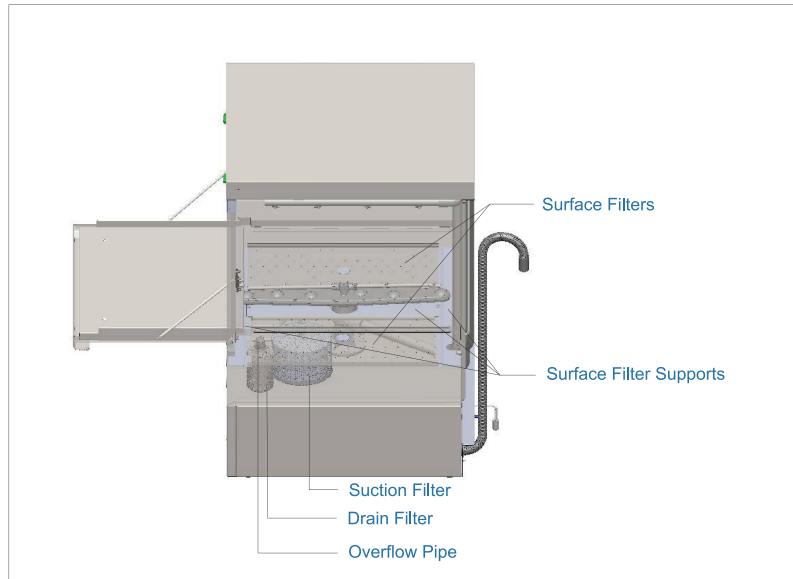

# Operation

## DAILY OPERATION

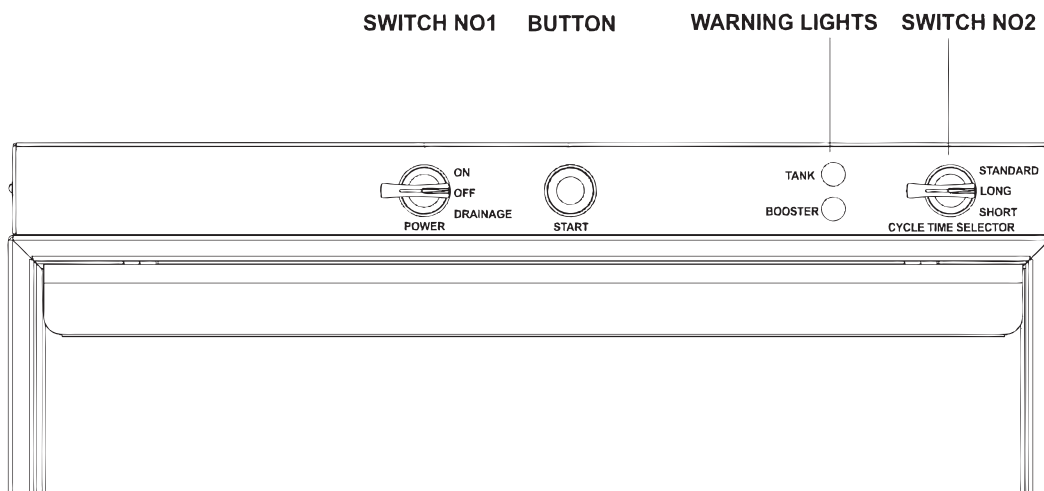

1. Check the chemical containers to be sufficient full.
2. Replace the overflow pipe and the surface screeners into correct position.
3. Turn on the dishwasher by putting the switch No 1 into on position.
4. Wait 20 minutes in order both the tank and booster to be fully heated.  
**Attention: the full heating process is finished when both warming lights are off.**

# Operation

5. Load the basket in a proper way and place it in the machine.

**Attention: All the residuals on the dishes and glasses must be removed.**

6. Select the preferable washing cycle time by the selector switch No 2.

Program	Wash time	Rinse time
Short	103 sec.	16 sec.
Standard	163 sec.	16 sec.
Long	223 sec.	16 sec.

7. Close the door and press the start button to initiate the washing cycle.

8. When the cycle time selector switch - No 2 starts flashing the program has finished and you can remove the basket.

Attention:

- The washing cycle time may be extended until the final rinse temperature reach 165°F / 74°C.
- Let the dishes and glasses to dry out of the dishwasher.
- Pay attention on removing the basket after the washing cycle as it may be HOT.

## INSTRUCTIONS FOR REGULAR OPERATION

The appliance is intended to clean dishes, cups, glasses, cutlery, etc. Be sure the items placed to be washed are suitable for dishwashing. Cutlery should be cleaned of heavy food residues, or soaked if not washed right after use. This machine is not intended for use with items which were used with acids, mineral oil, grease, gasoline or colors.

## PREPARATION OF DISHES FOR WASHING.

For best results avoid allowing food residues to dry. Remove bulk food residues, olive pips, lemon peels, tooth picks, etc., before placing the dishes in the basket.

If washing is delayed we recommend that you soak dishes and/or glasses which have food residues.

## FILLING OF BASKET

Place glasses and cups, with the opening facing down and not piled one on top of the other, in the appropriate baskets. Glasses should not touch each other (damage to glass or stains due to contact may occur).

Plates should be stacked vertically in appropriate baskets and not touching each other, look to the side of the baskets to see the recommended loading capacity.

Place tableware in the supplied plastic basket, with handles downwards or placed freely in a level plastic basket.

In every case, avoid overloading the basket.

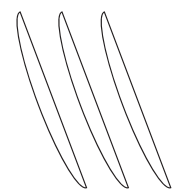

DISHES



BOWLS & PANS

- Check that the pump inlet filter has been placed in the correct position if it was removed for cleaning.
- Check that the overflow stand pipe is inserted correctly in its outlet.
- Close door.
- Turn power switch to on position (switches should now illuminate).
- The dishwasher will fill automatically.
- The booster indicator should come on to indicate that the inlet water to the rinse and fill system is being heated to the required rinse temperature (usually 165°F / 74°C).
- When the booster water has reached the correct temperature, the corresponding light switches off and the wash tank light comes on if the wash water temperature is not sufficiently hot (usually 165°F / 74°C).
- At initial daily start, allow about 10 to 20 minutes for machine to stabilize water temperatures to their proper temperatures.

**Note: After warm-up, one initial wash cycle should be performed to thoroughly mix soap and water and be sure unit is fully warmed up and ready to wash properly.**

- After initial warm-up, when all heater lights are off, the dishwasher is ready to wash.  
**Note: If door is opened during operation, the safety control will turn off the timer. Washing or rinsing will restart from beginning of wash cycle.**
- Open the door, insert the basket with the items (dishes, glasses, etc.) noting that heavy food residue has been removed. (If the automatic soap injection system is not used, pour the proper amount of liquid detergent manually into the wash tank). Close the door.
- To start the washing program, select the program desired and press the START button. The automatic program commences, with the green program indicator light in the program selector switch changing from flashing to steady.  
**Note: This unit is equipped with a “positive rinse temperature control and will not advance from wash to rinse unless the rinse water is at the preset temperature (usually about 195°F / 91°C).**
- When the program is finished, the green program light returns to flashing.
- Promptly open the door and remove the basket with the clean items. Use caution with hot items.
- Allow to dry.

If, after washing, there are stains from dirt or water spots, the cause may be one of the following:

- Wrong ratio of detergent to water.
- Rinsing water with very high mineral content.
- Improper quantity of rinse-aid.
- Wrong arrangement of items in the basket.
- Low water pressure during rinsing.
- Low water temperature during washing.
- Clogged or miss-positioned filters.
- Clogged jets.

## Note

- The wash temperature must be within  $\geq 74^{\circ}\text{C}$  &  $\leq 84^{\circ}\text{C}$  and the rinse temperature must be within  $\geq 74^{\circ}\text{C}$  &  $\leq 91^{\circ}\text{C}$ .
- Please check during the operation that the rinse water pressure is within its limits ( $20 \pm 5$  psi).



Do not remove the surface filters when machine is turned on. The heating element under the filters can cause burn.

# Maintenance

## SHUTTING DOWN AND DRAINING

1. Turn the power switch into draining position.
2. Remove the overflow pipe.  
**Attention: Do not remove the surface screeners and internal filters if the tank is not empty.**
3. Press the start button to start a draining cycle.  
**If a second draining is needed start a new cycle by pressing the start button.**
4. Remove the surface filters and clean them under running water.  
**Attention: DO NOT use any metal sponge to scratch the filters or the dishwasher surface.**
5. Remove the suction filter and the draining filter and clean them under running water.
6. Put the power switch no1 into off position.
7. Replace the filters and overflow pipe

## DAILY MAINTENANCE OPERATION.

- Turn the power switch off.
- Empty the wash tank by removing the overflow standpipe.
- Rinse the washing compartment to remove any dirt residues.
- Remove and clean the large pump filter.
- Reassemble the parts in reverse order.

**Never operate the dishwasher without the wash pump filter properly in place.**

## MAINTENANCE / CARE / REPAIR

Proper operation and safe use may be ensured only through the correct use of the appliance, as well as the compliance with the operation instructions, the corresponding specifications and the care and cleaning indications.

**Notice:** Before maintenance, other than daily interior cleaning, power and water supply to the machine must be turned off. The appliance should never be sprayed with water or high pressure cleaning solution, because any water or solution in the electrical elements will affect operation of the appliance as well as provide a potential for serious electrical shock.

**No safety systems should be disabled.**

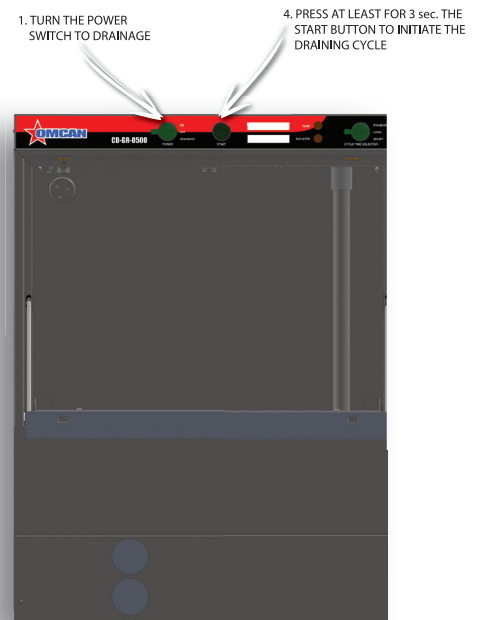

## REGULAR MAINTENANCE AND CLEANING.

Depending on local water hardness, the nozzles on the upper wash piping and rinse arms should be cleaned. Caution must be exercised to not damage the nozzles. If rinse nozzles are removed, they must be replaced with the slot in line with the rinse arm. **ATTENTION MUST BE GIVEN TO THE CORRECT INSTALLATION OF FILTERS, WASH ARMS, AND TEFLON BUSHINGS! REPLACE BUSHINGS IF WORN.** Clean the appliance with warm water and conventional cleaning aids. Stainless steel parts should never be cleaned them with “steel wool” wire brush, etc, since even the lightest contacts on the surfaces with steel may contaminate the stainless steel and cause rust formation. Use brushes made of polymer plastic or natural bristles or thin brass wire. Always keep brush movements in line with grain in the Stainless Steel so that you will not affect the appearance. Finally, rinse with clean water and dry thoroughly.

We remind you that corrosion (rust formation) on stainless steel surfaces is not created by itself, but rather due to the use of improper cleaning products (e.g. whitening or particularly caustic cleaning products based on chlorine). Occasionally calcium sediments form on the internal walls of the wash compartment, tubing, and booster chamber (due to mineral particles in the water), which may affect the correct operation of the appliance and which requires removal.

## SPARE PARTS, ACCESSORIES AND COMPONENTS

Spare parts and components are usually available at the authorized local service agency, or directly from Omcan, In case of warranty claims or complaints, you must supply the model and serial number of the appliance found on the specification label of the appliance.

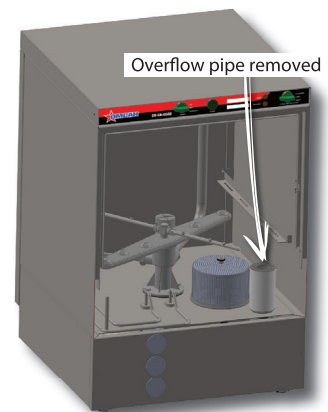
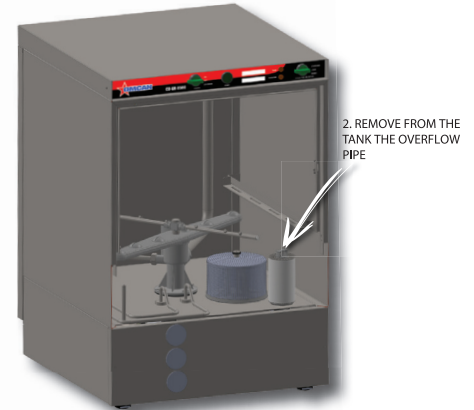

# Troubleshooting

PROBLEM	CAUSE	SOLUTION
The dishwasher does not operate.	No power to the machine.	Check the connection. Breaker or fuse has not been activated or is faulty.
	Control switch S1 not activated.	Turn switch S1 on.
	Switch S1 is faulty.	Refer to the authorized service agency, local dealer, or Omcan.
	Water supply not turned on.	Turn the supply on.
	Door is not closed.	Close the door.
	Water inlet valve is faulty.	Refer to the authorized service agency, local dealer, or Omcan.
Fill water runs continuously.	Overflow drain stand pipe not installed properly.	Install overflow drain stand pipe.
		Verify that overflow drain stand pipe is installed properly with overflow slots upwards.
The appliance operates, but the green operating pilot light does not illuminate.	The pilot light is faulty.	Change the pilot light.
	Wire lead to lamp disconnected.	Reconnect power lead.
	Lamp is out of it's socket.	Insert lamp.
Booster not heating.	Switch S1 or main switch or fuse has not been activated.	Check the switch S1 of the appliance and the main switch or fuse.
	The booster thermostat is faulty.	Refer to the authorized service agency, local dealer, or Omcan.
	The booster 105°C thermal fuse is faulty.	Refer to the authorized service agency, local dealer, or Omcan.
	Pressure switch is faulty.	Refer to the authorized service agency, local dealer, or Omcan.
	Booster heating contactor is faulty.	Refer to the authorized service agency, local dealer, or Omcan.
Booster heating operates, but pilot light does not turn on.	The pilot light is faulty.	Change the pilot light.
	Wire lead to lamp disconnected.	Reconnect power lead.
	Lamp is out of it's socket.	Reconnect power lead.
Wash tank heating does not operate.	The wash tank thermostat is faulty.	Refer to the authorized service agency, local dealer, or Omcan.
	The 90°C thermal fuse is burned or defective.	Refer to the authorized service agency, local dealer, or Omcan.

# Troubleshooting

Pump motor does not operate.	Main switch or fuse is not activated.	Activate main switch or fuse.
	The door is not closed.	Close the door.
	Main relay is faulty.	Refer to the authorized service agency, local dealer, or Omcan.
	Pump motor is faulty.	Refer to the authorized service agency, local dealer, or Omcan.
	Program timer is faulty.	Refer to the authorized service agency, local dealer, or Omcan.
Motor operates, but pump does not rotate.	An object has jammed the pump impeller.	Refer to the authorized service agency, local dealer, or Omcan.
	Hard water deposits or detergent have been petrified following non operation of the appliance.	Loosen deposits by rotating screw on rear side of pump motor.
Washed items do not dry (dishes, glasses, etc.)	Rinse aid supply is empty.	Replace or refill rinse aid container.
	Rinse aid “dozer” valve is defective.	Refer to the detergent supplier, authorized service agency, local dealer, or Omcan.
	Timer is faulty.	Refer to the authorized service agency, local dealer, or Omcan.
	Rinse arms (upper and/or lower) do not rotate.	Clean nozzles.
Replace Teflon bushings if worn. <b>Note:</b> take caution to not install rinse arm without bushings.		

## REFERENCE

Item Number	Model Number	Description	Manufacturer Model Number
46320	CD-GR-0500	Dishwasher Undercounter 20" x 20" / 508mm x 508mm 208-240V/60/1 CE cETLus TUV NSF Certified	V500 NSF

# Parts Breakdown

Model CD-GR-0500 46320

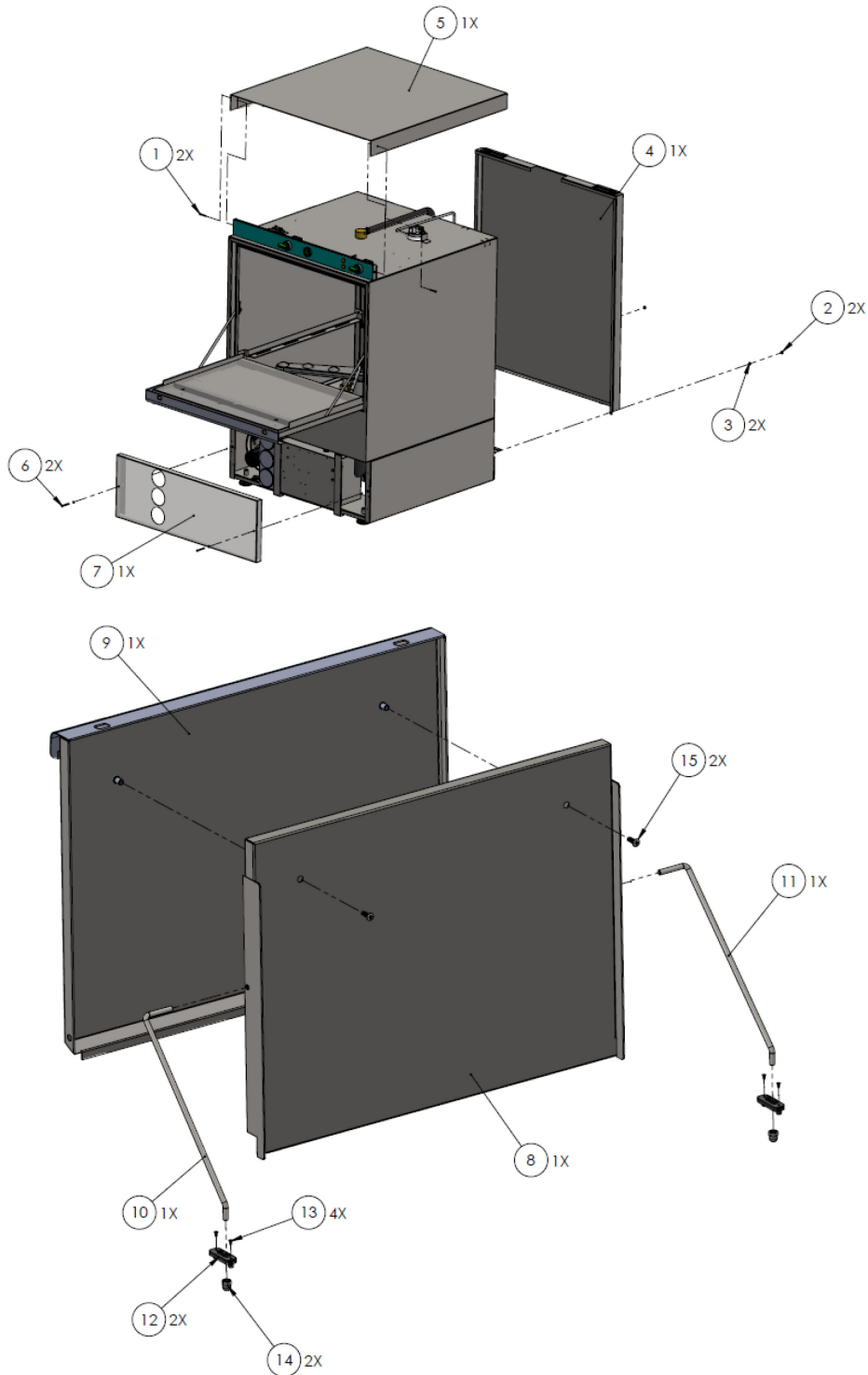

# Parts Breakdown

Model CD-GR-0500 46320

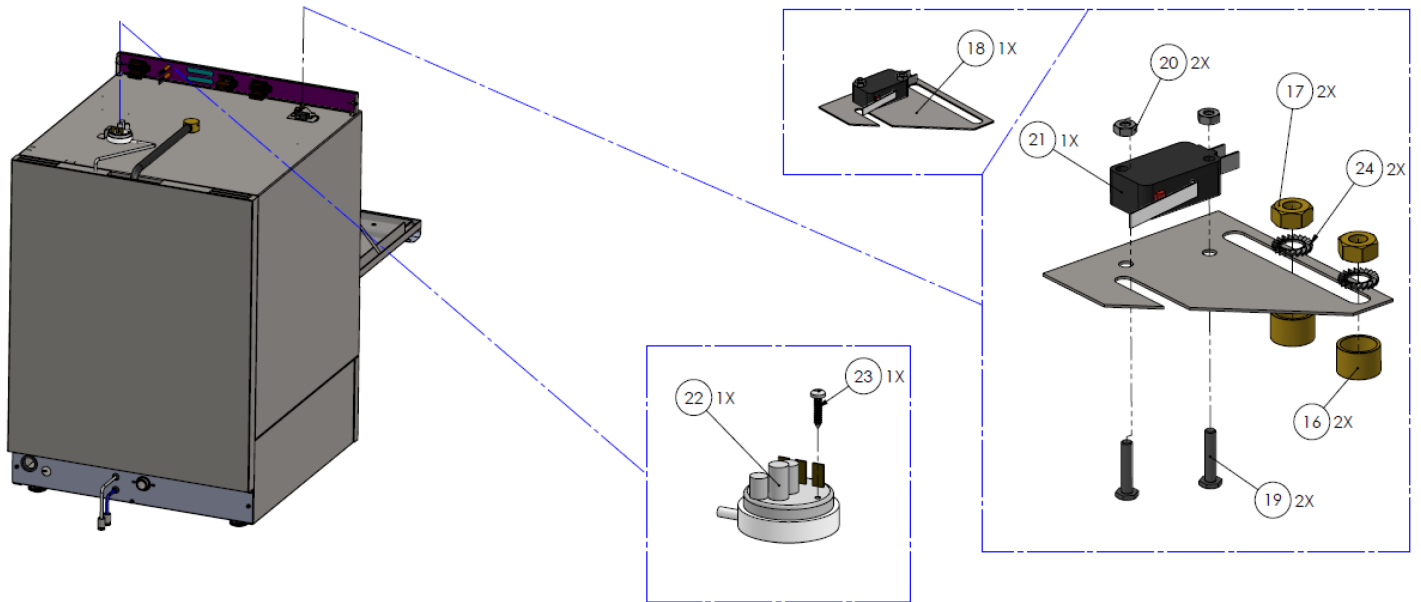

# Parts Breakdown

Model CD-GR-0500 46320

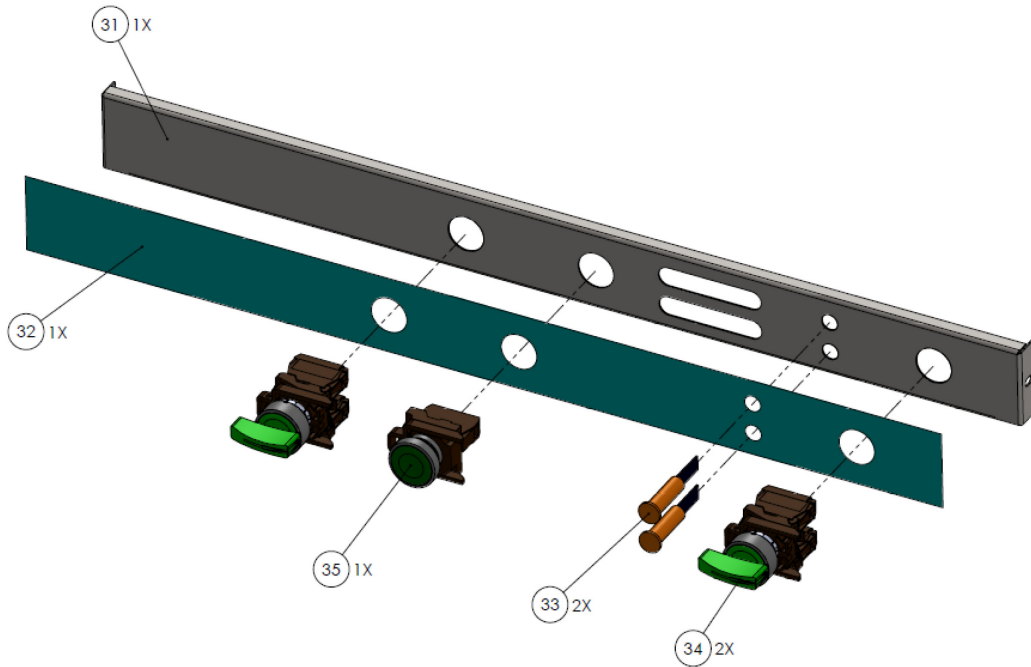
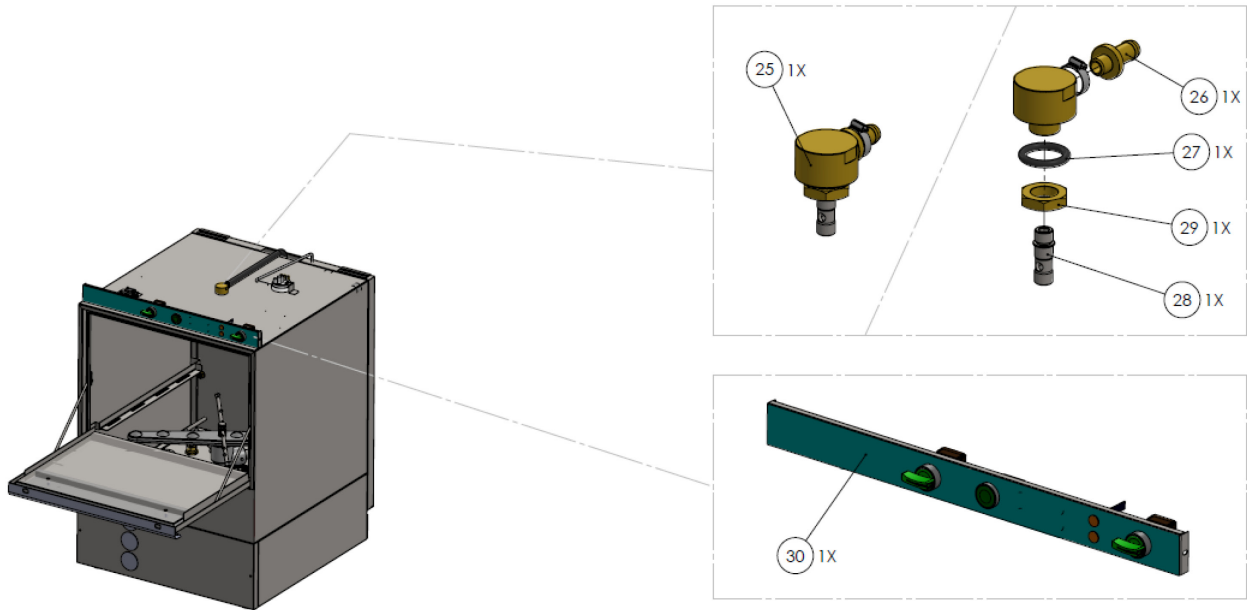

# Parts Breakdown

Model CD-GR-0500 46320

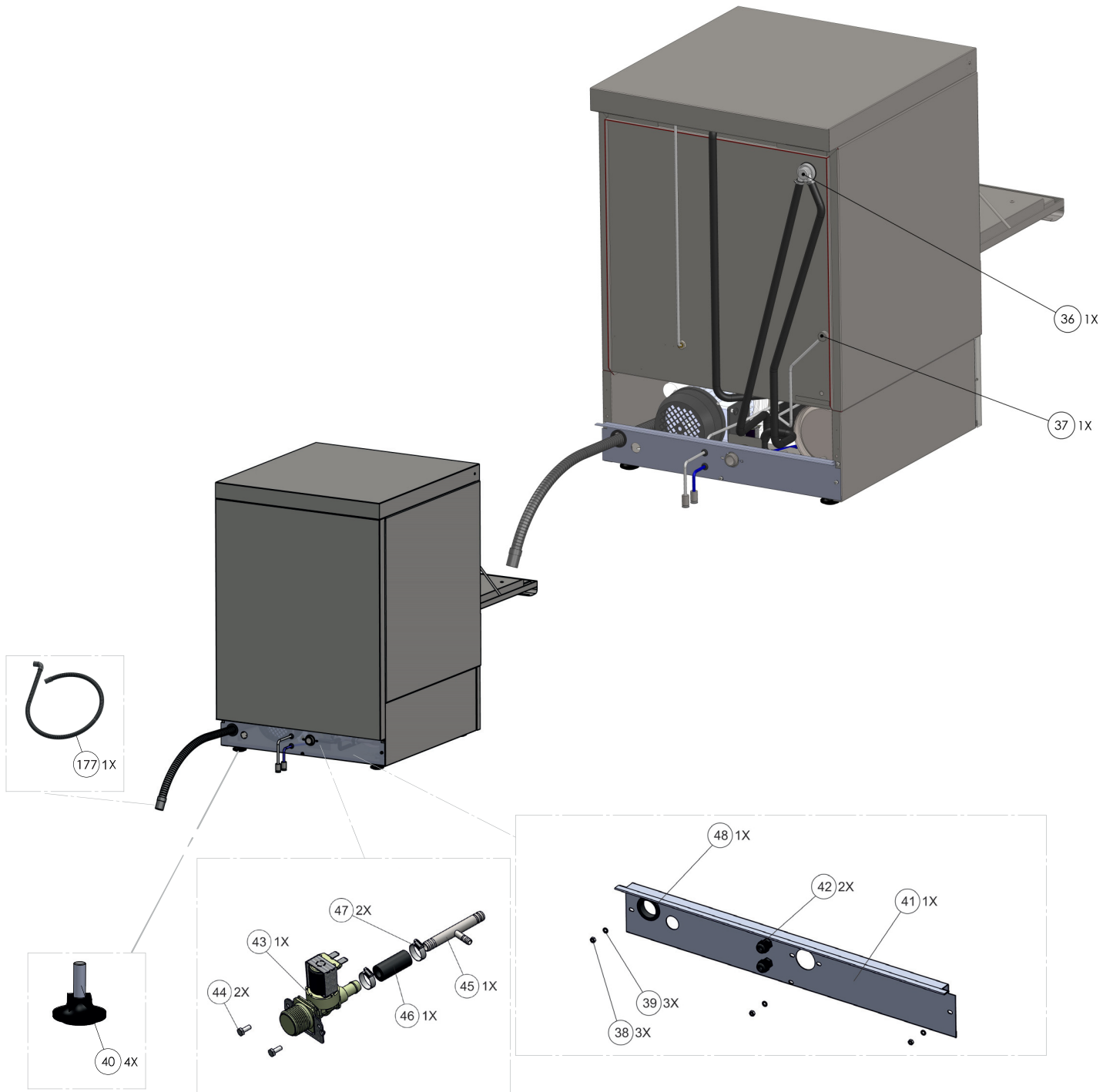

# Parts Breakdown

Model CD-GR-0500 46320

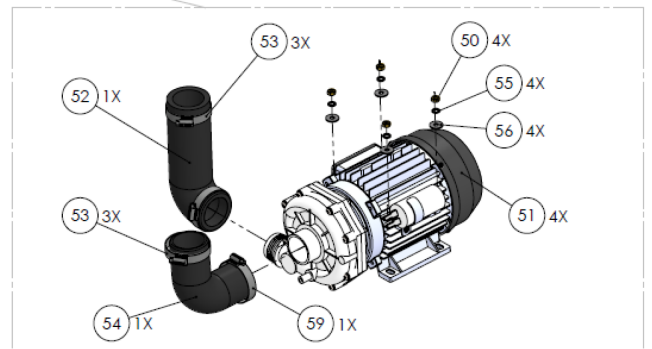
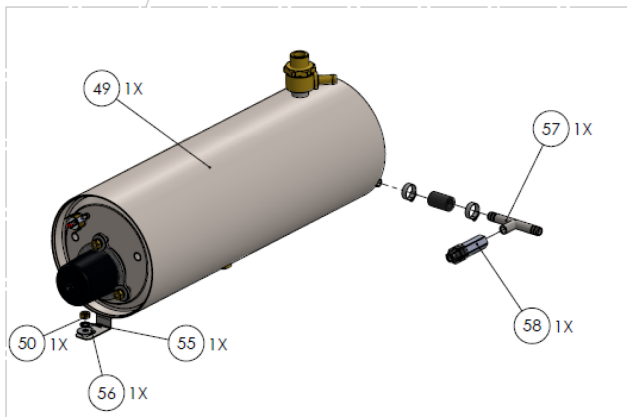
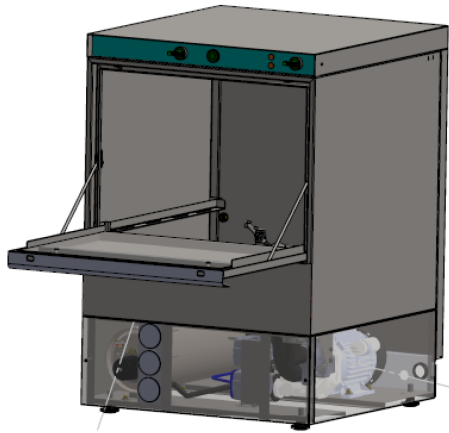

# Parts Breakdown

Model CD-GR-0500 46320

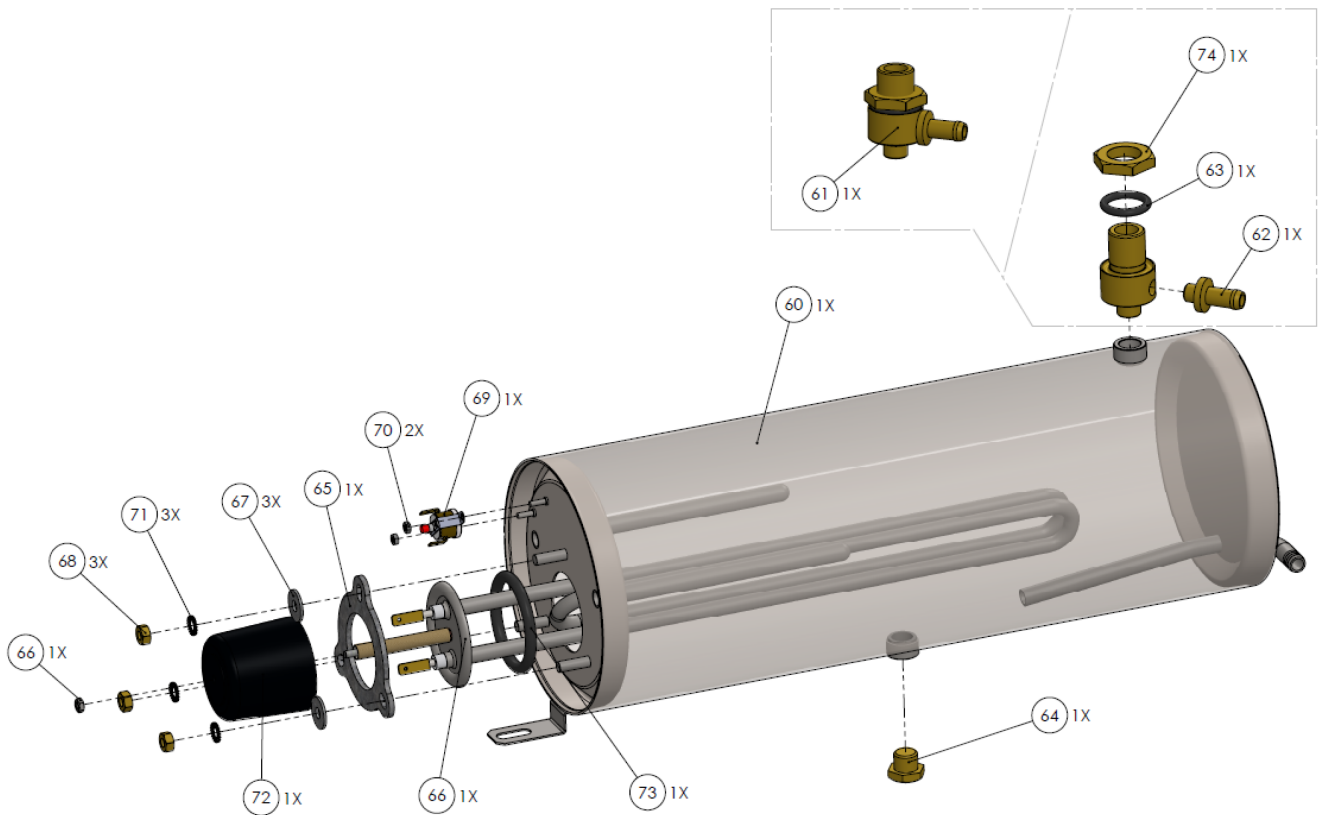

# Parts Breakdown

Model CD-GR-0500 46320

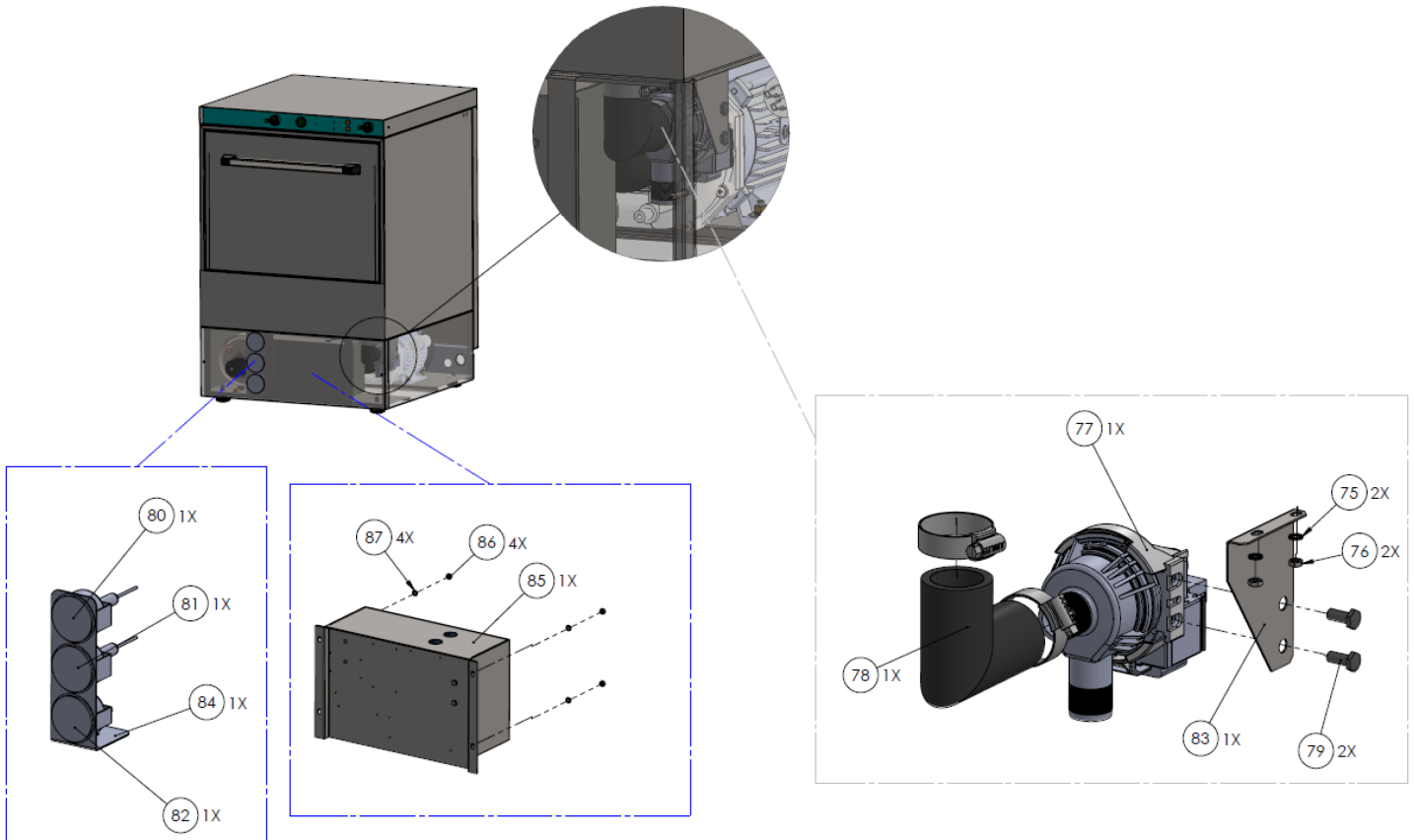

# Parts Breakdown

Model CD-GR-0500 46320

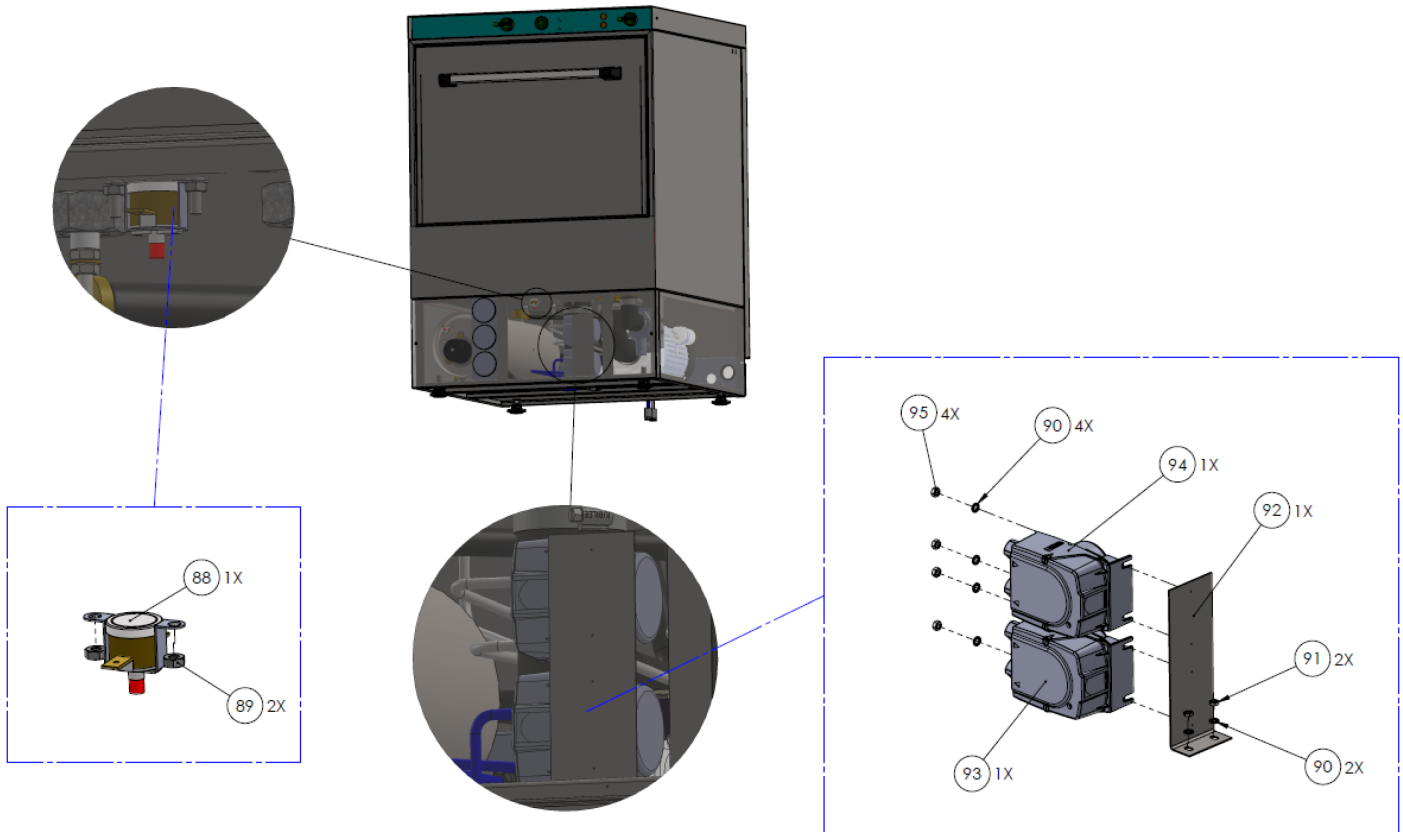

# Parts Breakdown

Model CD-GR-0500 46320

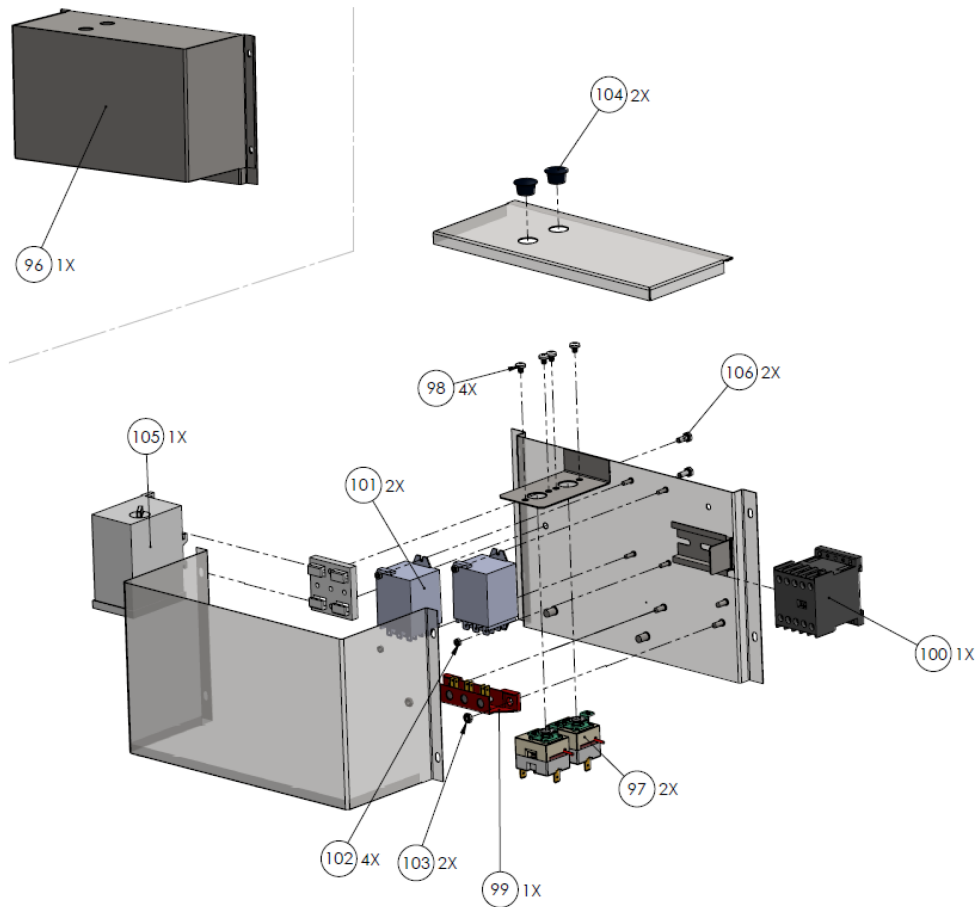

# Parts Breakdown

Model CD-GR-0500 46320

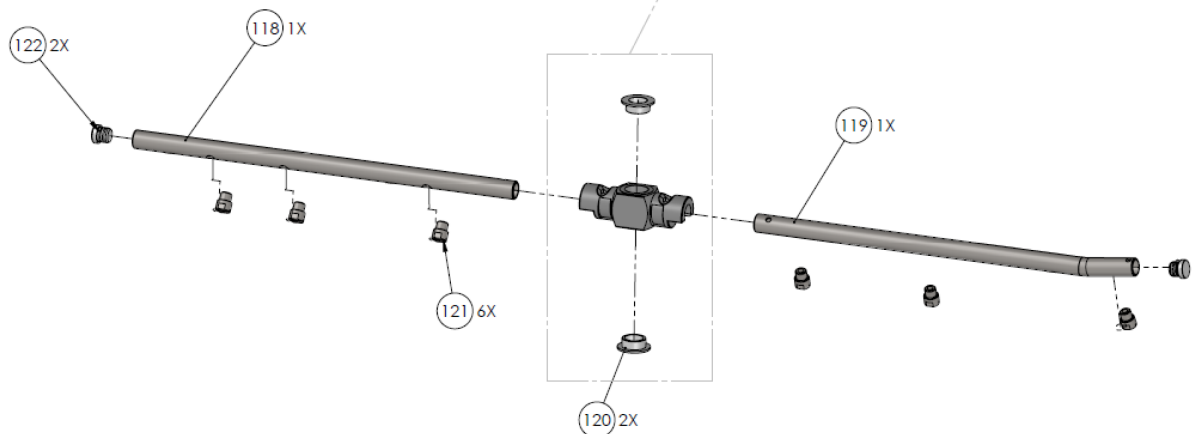
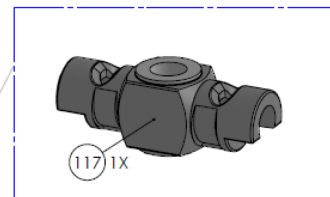
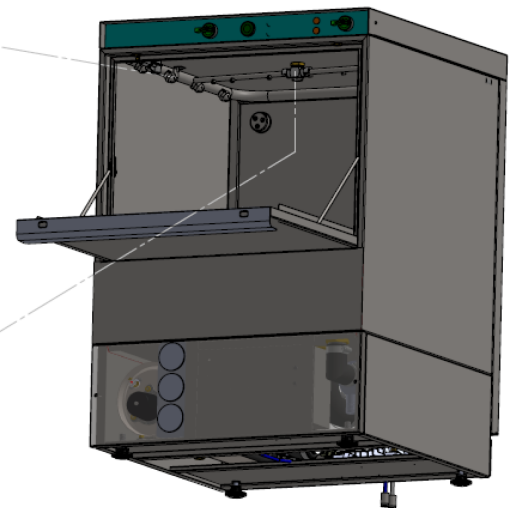
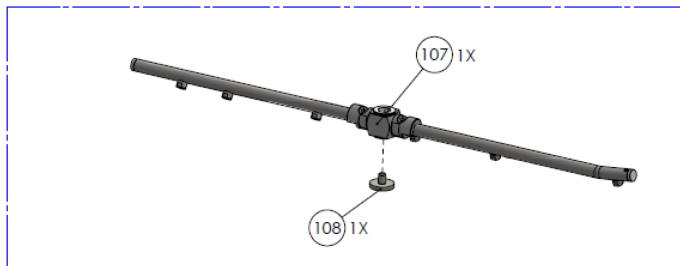
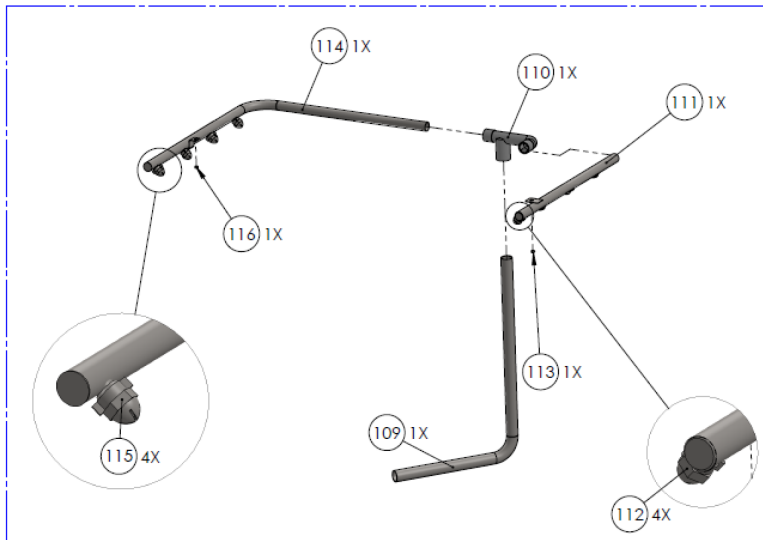

# Parts Breakdown

Model CD-GR-0500 46320

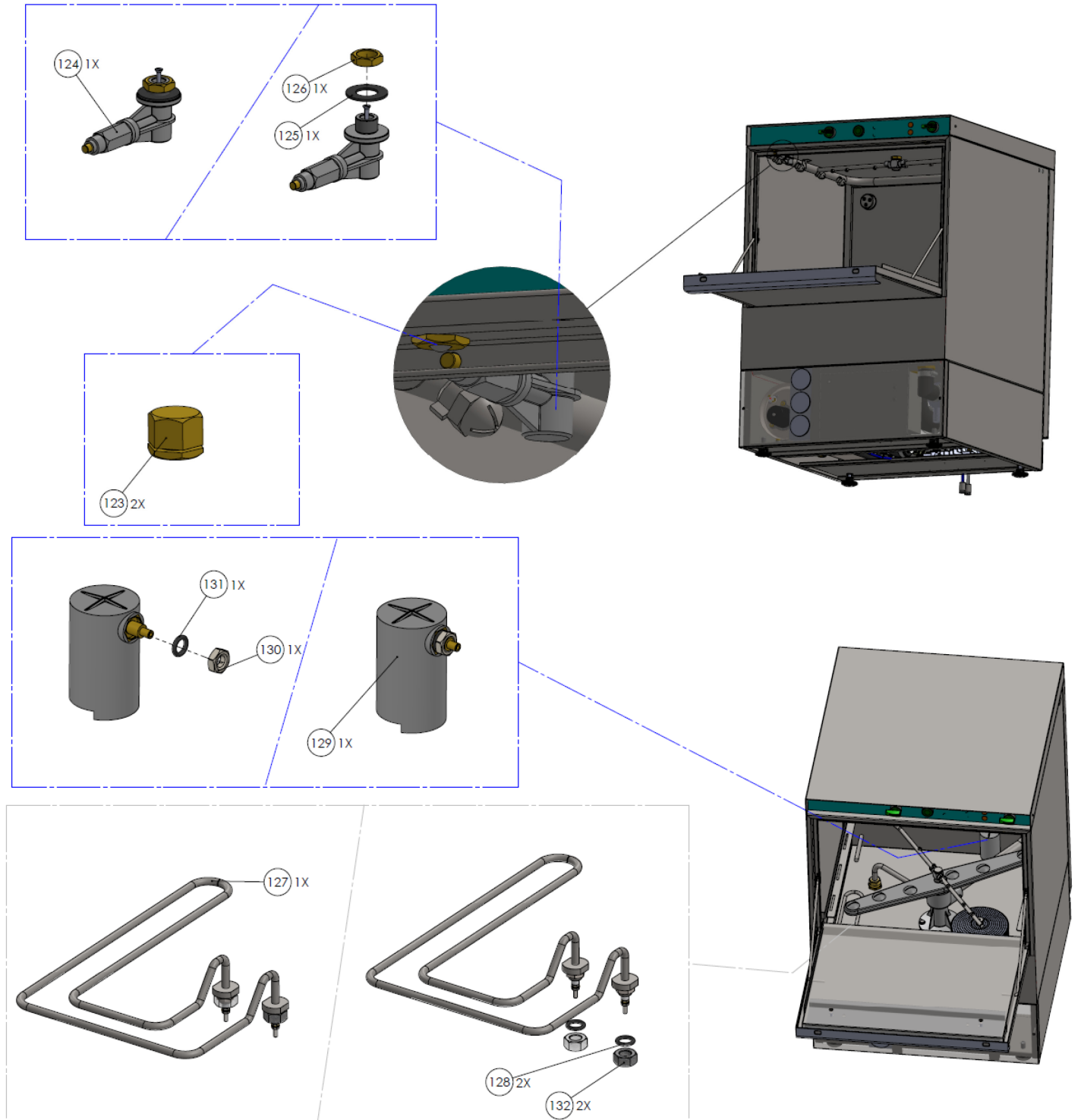

# Parts Breakdown

Model CD-GR-0500 46320

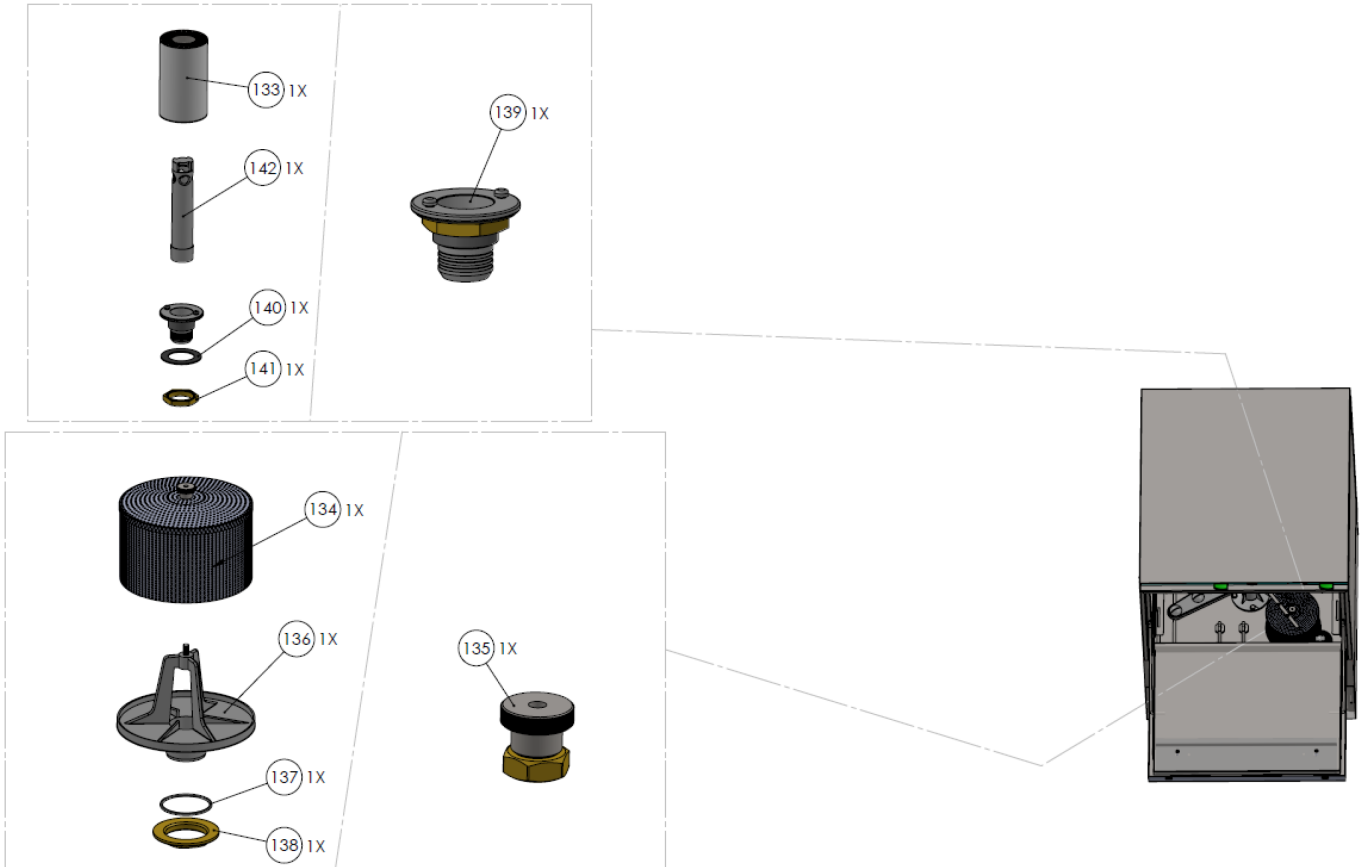

# Parts Breakdown

Model CD-GR-0500 46320

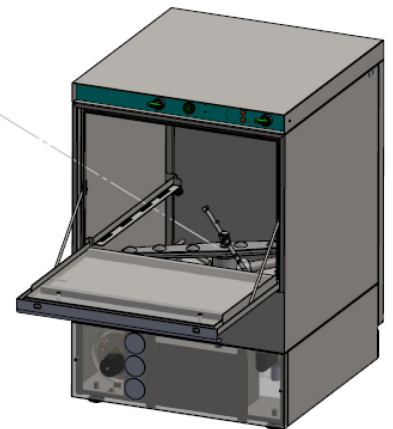
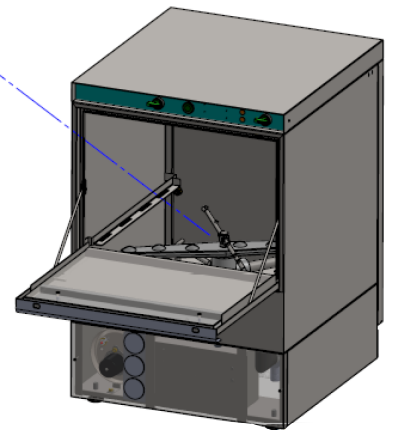
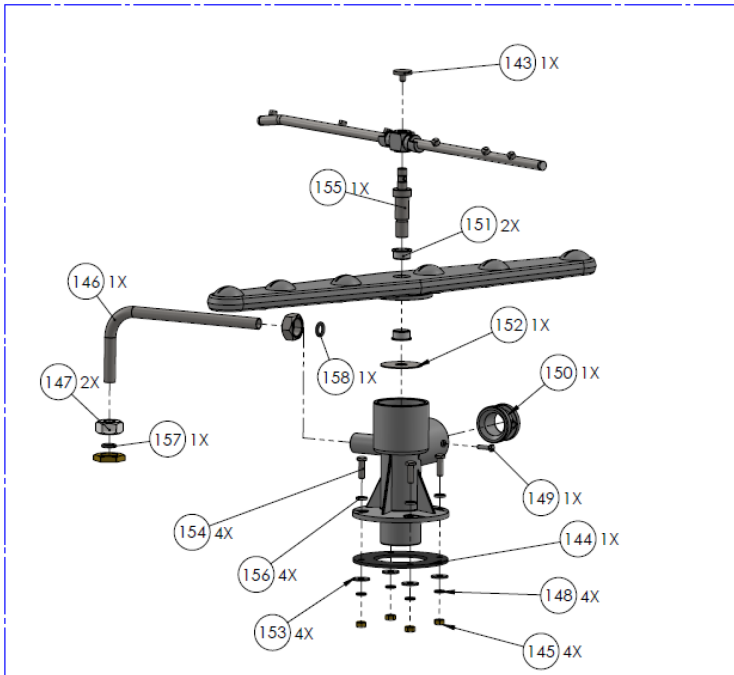

# Parts Breakdown

Model CD-GR-0500 46320

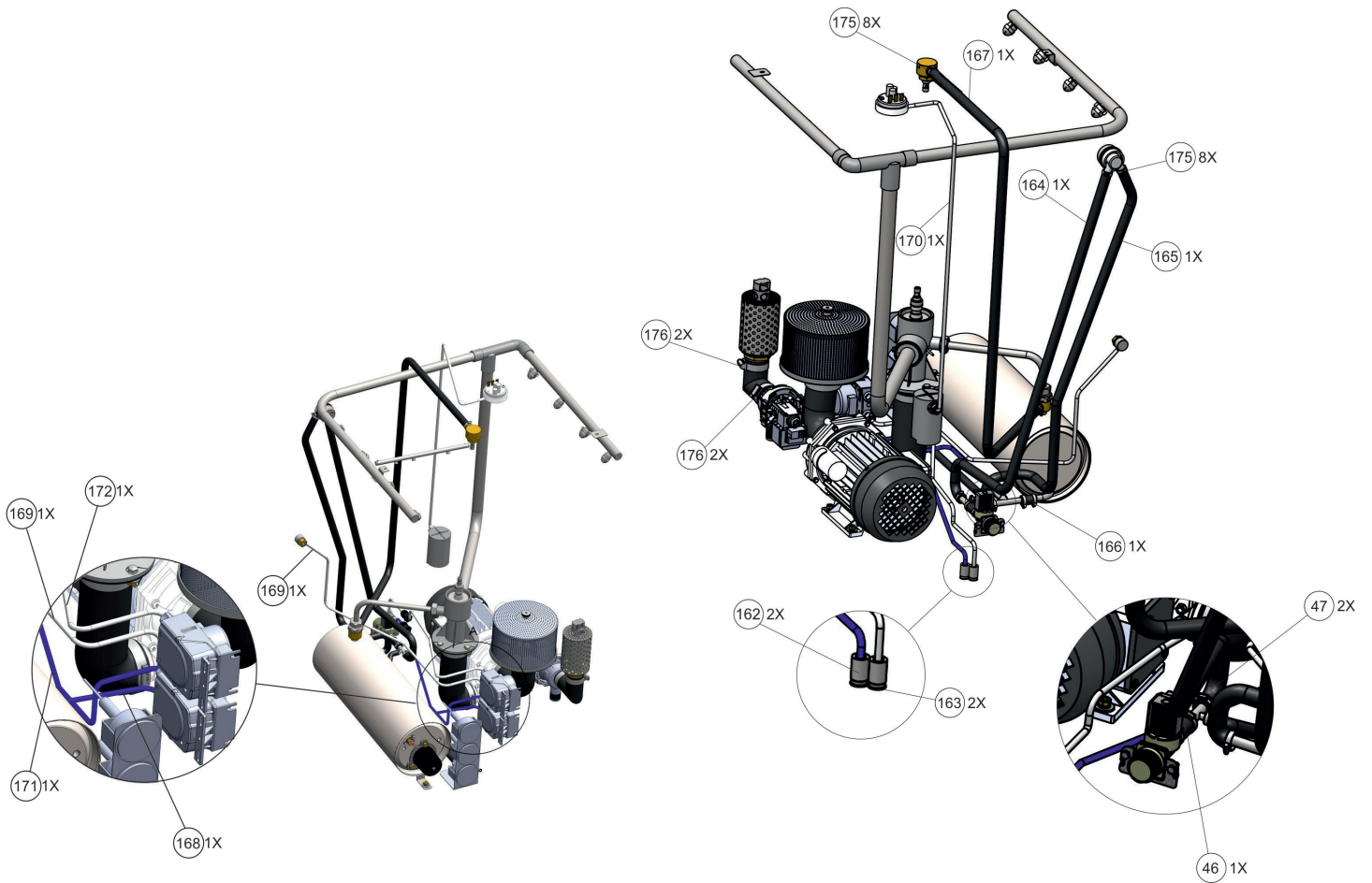

# Parts Breakdown

Model CD-GR-0500 46320

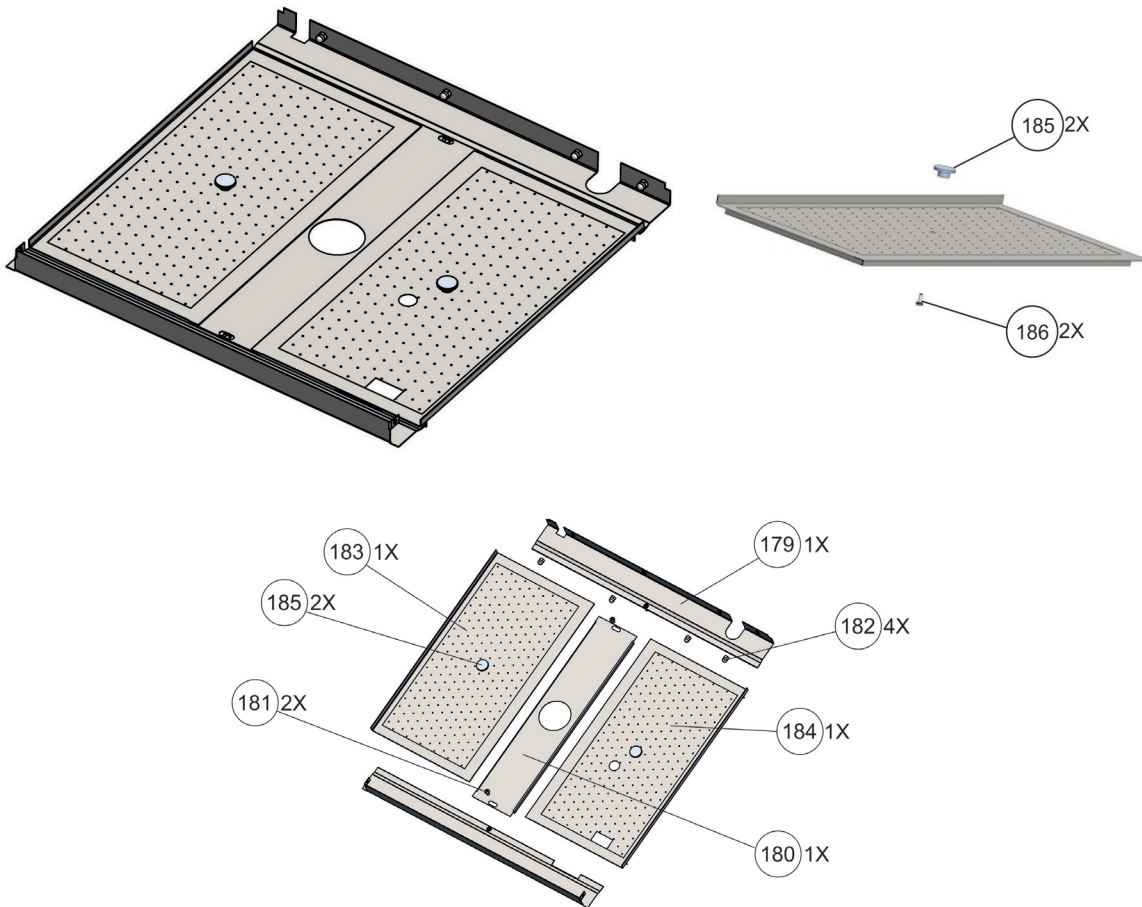

# Parts Breakdown

**Model CD-GR-0500** 46320

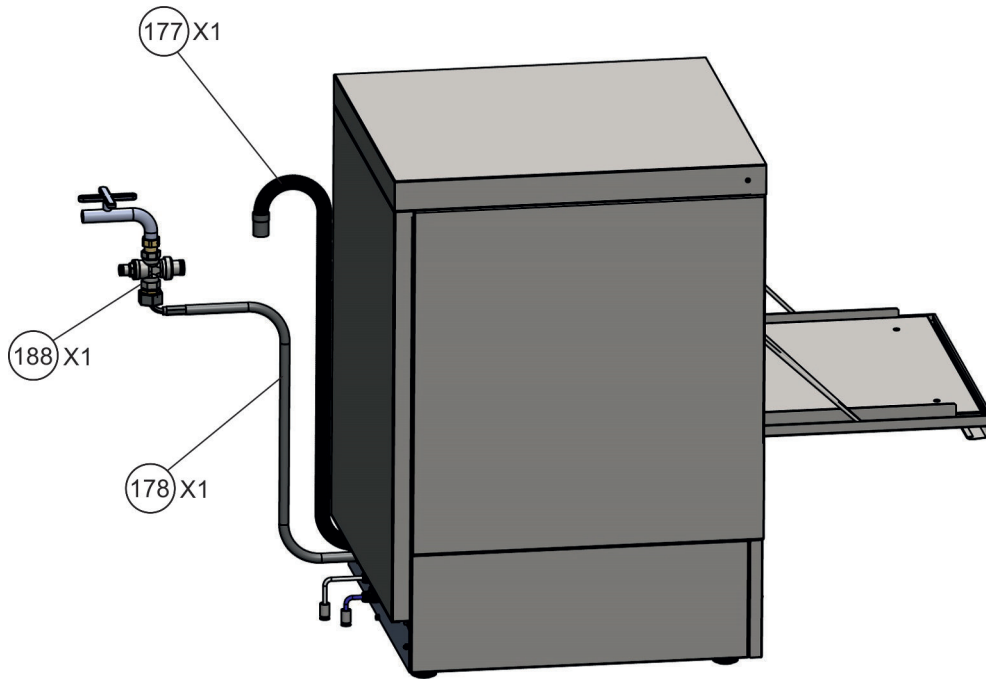

# Parts Breakdown

## Model CD-GR-0500 46320

Item No.	Description	Position	Item No.	Description	Position	Item No.	Description	Position
60951	INOX Screw M4x15 for V500	1	41104	Cycle Selection Switch 0-1-2 LED for V500	34	73884	Washer Steel 6x18 for V500	67
60952	INOX Nut M4 for V500	2	41105	Start Button Switch Green for V500	35	73843	Nut M6 Galvanised for V500	68
73831	Lock Washer INOX 4 for V500	3	73839	Non Return Valve (DVGW) for V500	36	41088	Boiler Thermofuse 105°C for V500	69
73753	Back Cover INOX for V500	4	73773	Detergent Tank Injector for V500	37	73821	INOX Nut M3 for V500	70
73879	Upper Cover INOX for V500	5	60952	INOX Nut M4 for V500	38	73800	Galvanised Lock Washer 6.4x11x0.7 for V500	71
60953	INOX Screw M4x30 for V500	6	73831	Lock Washer INOX 4 for V500	39	73802	Heater Element Cover for V500	72
73798	Front Cover INOX for V500	7	41141	Small Leveling Feet Black for V500	40	60978	O-Ring 45x6 for V500	73
73754	Back Part of the Door V-K for V500	8	73818	INOX Lower Back Cover for V500	41	73841	Nut 1/2 for V500	74
73799	Front Part of the Door V-K for V500	9	60968	Cable Rubber Protector for V500	42	73831	Lock Washer INOX 4 for V500	75
60954	Door Right Support Axle M6x300 for V500	10	41112	Water Input Solenoid Valve for V500	43	73834	M4 Nut Galvanised for V500	76
60955	Door Left Support Axle M6x300 for V500	11	60969	Galvanised Bolt M4x10 for V500	44	41113	Tank Draining Pump 230V-65W for V500	77
73848	Plastic Guide for Door Axle for V500	12	60970	Inlet Valve Extension to Pressure Gauge for V500	45	73784	Draining Pump Inlet Pipe for V500	78
73825	INOX Screw 2.9x10 for V500	13	60971	Gasket for Inlet Hose for V500	46	73835	M6 Galvanised Bolt for V500	79
73774	Domed Cap Nut M6 for V500	14	60972	Fitting 1/4x7 Male for V500	47	60979	Thermometer for Tank 2in 20/220F for V500	80
60956	Inox Tappered Screw M5x16 for V500	15	60973	Pipe Rubber Protector for V500	48	60980	Thermometer for Booster 2in 20/220F for V500	81
73862	Spacer for Door Switch for V500	16	60974	Boiler Complete with Heater Element for V500	49	60981	Pressure Gauge 2in 0/60 PSI 1/4 NPT for V500	82
73843	Nut M6 Galvanised for V500	17	73843	Nut M6 Galvanised for V500	50	73809	INOX Base for Draining Pump for V500	83
41097	Door Switch Electrical Part for V500	18	73851	Pump 0.75HP, 208-240V, 60HZ, 2P, UL for V500	51	60982	Bracket for Pressure Gauge - Thermometer for V500	84
60957	Galvanised Nut M3 for V500	19	60975	Wash Pump Hose (Outlet) for V500	52	73786	Electrical Box Complete for V500	85
73821	INOX Nut M3 for V500	20	73766	Clamp 40-60 for V500	53	60952	Lock Washer INOX 4 Dia for V500	86
60958	Door Microswitch 16A for V500	21	73881	Wash Pump Hose (Input) for V500	54	73831	Lock Washer INOX 4 for V500	87
41090	Pressostat Switch for V500	22	73800	Galvanised Lock Washer 6.4x11x0.7 for V500	55	41087	Tank Thermofuse 90°C for V500	88
60959	Tapping Screw 3.5x9.5 for V500	23	73884	Washer Steel 6x18 for V500	56	73821	INOX Nut M3 for V500	89
73800	Galvanised Lock Washer 6.4x11x0.7 for V500	24	73870	Tee-Connection Boiler with 1/8 for V500	57	73831	Lock Washer INOX 4 for V500	90
73880	Upper Rinsing Base Complete for V500	25	73840	Non Return Valve for Rinse Aid Pump for V500	58	73834	M4 Nut Galvanised for V500	91
60960	Fittings 1/4x10 for V500	26	60976	Clamp 35-50 for V500	59	73761	Bracket for Two Peristaltic Pumps for V500	92
73749	O-Ring 20x4 for V500	27	73760	Boiler 140/400 for V500	60	60984	Peristaltic Rinse Aid Pump for V500	93
60961	INOX Axle Rinse Base BL, VE, KN for V500	28	73844	Outlet Base Boiler for V500	61	60985	Peristaltic Detergent Pump for V500	94
60962	Nut 3/8 for V500	29	60960	Fittings 1/4x10 for V500	62	60952	INOX Nut M4 for V500	95
60963	Control Panel with Switches for V500	30	73749	O-Ring 20x4 for V500	63	60987	Electrical Board Casing for V500	96
60964	Switch Panel INOX V50 for V500	31	73757	Boiler Drain Threaded Cap for V500	64	41118	Thermostat 0-90°C 1500mm for V500	97
60965	Film for Switch Panel for V500	32	73758	Boiler Element Fitting Base for V500	65	73801	Galvanised Machine Screw M4x5 for V500	98
41120	Light Indicator Orange for V500	33	41103	Boiler Heating Element 3 Kw for V500	66	73850	Power Supply Board Three Con. for V500	99

# Parts Breakdown

## Model CD-GR-0500 46320

Item No.	Description	Position	Item No.	Description	Position	Item No.	Description	Position
41119	Relay Magnetic Contactor for V500	100	41102	Tank Heating Element 2.8 Kw for V500	127	73816	INOX Hex Bolt M6x20 for V500	154
73837	Micro Relay 11 Pins with Faston for V500	101	60995	O-Ring 14x3.5 for V500	128	73751	Axle INOX for Base Down for V500	155
73821	INOX Nut M3 for V500	102	41091	Pressostat Chamber for V500	129	73871	Teflon 12-6-2 for V500	156
73834	M4 Nut Galvanised for V500	103	60996	Nut M10 for V500	130	41140	O-Ring 10.5x3 for V500	157
73849	Plug Plastic 16 for V500	104	41140	O-Ring 10.5x3 for V500	131	61004	O-Ring 4x11 for V500	158
60988	Electronic Timer PM21 NSF for V500	105	73842	Nut 14 (Galvanised) for V500	132	41098	Rinse Arm Complete for V500	159
60969	Galvanised Bolt M4x10 for V500	106	73782	Drain Pump Filter for V500	133	61005	Washing Base Down V-K Complete for V500	160
41098	Rinse Arm Complete for V500	107	60997	Filter in the Tank for the Pump V-KN for V500	134	41094	Washing Arm Lower for V500	161
41099	Wash and Rinse Group Fixing Screw for V500	108	73794	Filter Retaining Nut for V500	135	61006	Balance F15x20 for V500	162
73887	Washing Upper System INOX Supply Pipe for V500	109	60998	Plastic Base for Tank Filter V-K for V500	136	61007	Filter Plastic for Rinse Aid Valve for V500	163
41095	Upper Washing Arm Plastic Connector for V500	110	60999	O-Ring 52x2.5 for V500	137	61008	Washing Machine Hose Black 10x16.5 for V500	164
73886	Washing Upper System Up-Right for V500	111	73780	Drain and Overflow Base Nut 1 1/2 for V500	138	61009	Washing Machine Hose Black 10x16.5 for V500	165
41086	Sprayer for Upper Washing Arm for V500	112	41093	Drain and Overflow Plastic Base for V500	139	61010	Washing Machine Hose Black 10x16.5 for V500	166
60952	INOX Nut M4 for V500	113	61000	Rubber Gasket 35x55x1 for V500	140	61011	Washing Machine Hose Black 10x16.5 for V500	167
73885	Washing Upper System Up-Left for V500	114	61001	Bronze Nut M36 for V500	141	61012	Tube PVC Blue 4x6 for V500	168
41086	Sprayer for Upper Washing Arm for V500	115	61002	Drain and Overflow Valve Plastic Part for V500	142	61013	Tubo Cristallo 4x6 for V500	169
60952	INOX Nut M4 for V500	116	41099	Wash and Rinse Group Fixing Screw for V500	143	61014	Tubo Cristallo 4x6 for V500	170
73846	Plastic Base for Rinsing Arms for V500	117	61003	Rubber Gasket 103x58x3 for V500	144	61015	Tube PVC Blue 4x6 for V500	171
73860	Rinsing Arm Single - B for V500	118	73843	Nut M6 Galvanised for V500	145	61016	Tubo Cristallo 4x6 for V500	172
73859	Rinsing Arm - A for V500	119	73857	Rinse Pipe INOX for V500	146	61017	Washing Machine Hose Black 6x12 for V500	173
41101	Teflon 18x6 for V500	120	41139	Rinse Pipe Retaining Nut for V500	147	61018	Clamp 8-12 for V500	174
41085	Sprayer for Rinsing Arm for V500	121	73800	Galvanised Lock Washer 6.4x11x0.7 for V500	148	61019	Clamp 10-16 for V500	175
60992	Cap for Rinse Arms for V500	122	73814	INOX Hex Bolt M4x15 for V500	149	73765	Clamp 25-40 for V500	176
41089	Door Snap Set for V500	123	73750	Adaptor 40-25 for Wash Base for V500	150	60376	Elbow Draining Pipe OD22-ID19mm 1,5M for V500	177
41096	Door Switch Mechanical Part for V500	124	41100	Teflon 23/10 for V500	151	14849	Pipe Fitting for Detergent Pump for V500	
60993	Rubber Gasket 16x30x3 for V500	125	73796	Flow Control Disk for Base for V500	152			
60994	Nut for Door Switch for V500	126	73884	Washer Steel 6x18 for V500	153			

# Electrical Schematics

## Model CD-GR-0500 46320

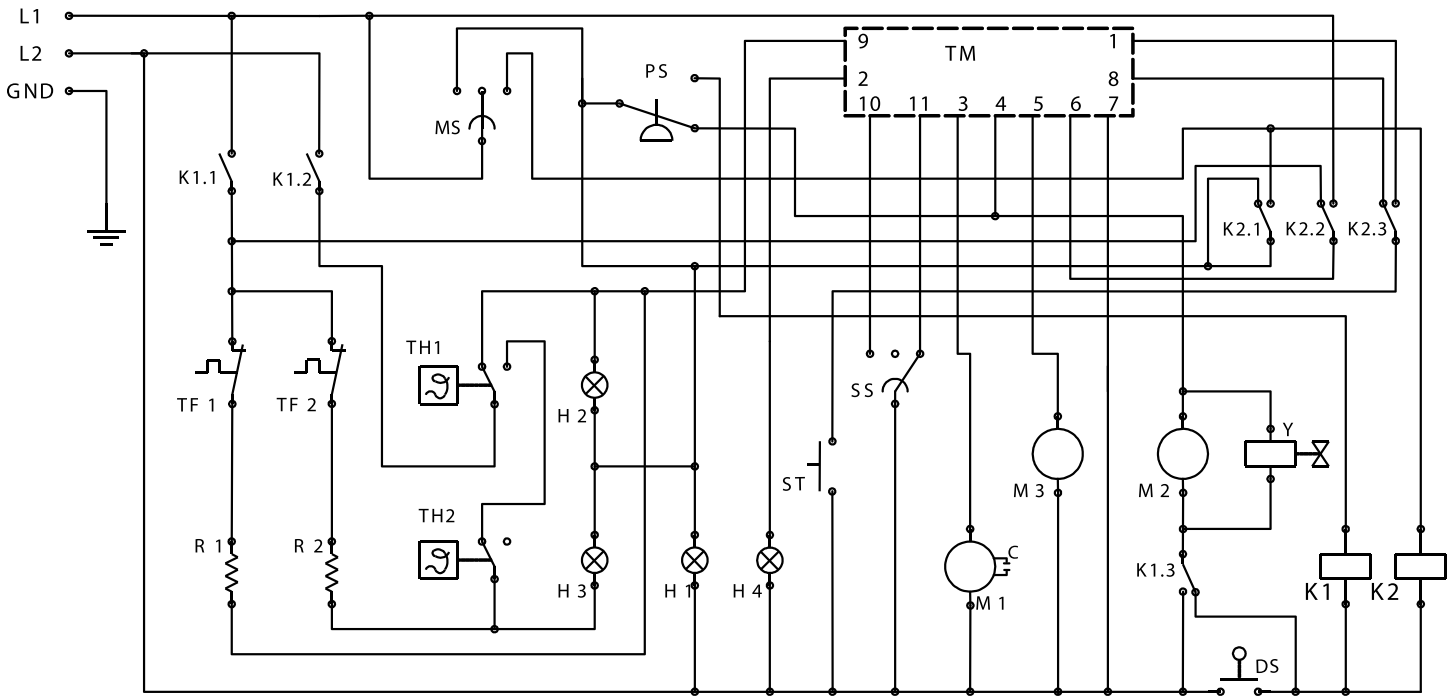

MS	Main Switch	TH	Thermostat	R1	Booster's Heating Element	M2	Detergent Pump Motor
ST	Start Switch	SS	Program Selector Switch	R2	Tank's Heating Element	M3	Drainage Pump Motor
DS	Doors Cut Off Switch	TM	Electronic Timer	H	Indicator Lamp	K2	Microrelay
PS	Pressure Switch	C	Capacitor	Y	Water Inlet Valve		
TF	Thermofuse	K1	Magnetic Contactor	M1	Wash Pump Motor		







# INSTALLATION REQUIREMENTS AND CHECKLIST

**The Dishwasher must be installed by a certified plumber.  
Failing to follow the instructions below will void the warranty.**



**\*This checklist *must* be returned with warranty card.\***

Installer  
Signature Below:

- 1. Check water hardness. If water hardness exceeds 7 grains per gallon, a water softener must be installed.
- 2. Ensure the correct placement and leveling of the machine as per the manual (page 10).
- 3. The water supply hose / pipe should be flushed before the final connection (page 12).
- 4. The dishwasher must be connected to a hot water source with a minimum temperature of 40° Celcius / 104° Fahrenheit.
- 5. Adjust water pressure using the PRV to 20 PSI, while filling the machine with water.
- 6. Rinse and detergent containers can be adjusted at the bottom of the machine by rotating the adjustment screws on the pumps. Adjust rinse/detergent flow to manufacturers recommendations. 2.6 ml per rotation for DETERGENT – 1.2 ml per rotation for RINSE. ***\*Rinse/Detergent containers must be equal or lower in height than the pumps\****
- 7. Do not add an extension to the drain hose, drain connections must be made in the same flow with the drain pipe. Do not install drain hose to exceed 26 inches / 65 cm above the ground (page 13).
- 8. If the tank temperature gauge is not inside the green zone, the installer must adjust to 80° Celsius / 176° Fahrenheit.
- 9. If the booster gauge is not inside the green zone, the installer must adjust to 80° Celsius / 176° Fahrenheit.
- 10. If no water filtration/softener system is used, descale every 4 weeks.

**\*Please read through owner's manual completely for all instructions.\***

Company Name: \_\_\_\_\_  
Company Phone Number: \_\_\_\_\_  
Installed By: \_\_\_\_\_  
Date Installed: \_\_\_\_\_  
Signature of Installer: \_\_\_\_\_



# Warranty Registration

Thank you for purchasing an Omcan product. To register your warranty for this product, complete the information below, tear off the card at the perforation and then send to the address specified below. You can also register online by visiting:

Merci d'avoir acheté un produit Omcan. Pour enregistrer votre garantie pour ce produit, complétez les informations ci-dessous, détachez la carte au niveau de la perforation, puis l'envoyer à l'adresse spécifiée ci-dessous. Vous pouvez également vous inscrire en ligne en visitant:

Gracias por comprar un producto Omcan usted. Para registrar su garantía para este producto, complete la información a continuación, cortar la tarjeta en la perforación y luego enviarlo a la dirección indicada a continuación. También puede registrarse en línea en:

<https://omcan.com/warranty-registration/>

For mailing in Canada

Pour postale au Canada

Por correo en Canadá

**OMCAN**

PRODUCT WARRANTY REGISTRATION

3115 Pepper Mill Court,

Mississauga, Ontario

Canada, L5L 4X5

For mailing in the US

Pour diffusion aux États-Unis

Por correo en los EE.UU.

**OMCAN**

PRODUCT WARRANTY REGISTRATION

4450 Witmer Industrial Estates, Unit 4,

Niagara Falls, New York

USA, 14305

*or email to: [service@omcan.com](mailto:service@omcan.com)*



Purchaser's Information

Name: \_\_\_\_\_

Address: \_\_\_\_\_

City: \_\_\_\_\_ Province or State: \_\_\_\_\_ Postal or Zip: \_\_\_\_\_

Country: \_\_\_\_\_

Dealer from which Purchased: \_\_\_\_\_

Dealer City: \_\_\_\_\_ Dealer Province or State: \_\_\_\_\_

Invoice: \_\_\_\_\_

Model Name: \_\_\_\_\_ Model Number: \_\_\_\_\_

Machine Description: \_\_\_\_\_

Date of Purchase (MM/DD/YYYY): \_\_\_\_\_

Would you like to extend the warranty?  Yes  No

Company Name: \_\_\_\_\_

Telephone: \_\_\_\_\_

Email Address: \_\_\_\_\_

Type of Company:

Restaurant  Bakery  Deli

Butcher  Supermarket  Caterer

Institution (*specify*): \_\_\_\_\_

Other (*specify*): \_\_\_\_\_

Serial Number: \_\_\_\_\_

Date of Installation (MM/DD/YYYY): \_\_\_\_\_

**Thank you for choosing Omcan | Merci d'avoir choisi Omcan | Gracias por elegir Omcan**



Since 1951 Omcan has grown to become a leading distributor of equipment and supplies to the North American food service industry. Our success over these many years can be attributed to our commitment to strengthen and develop new and existing relationships with our valued customers and manufacturers. Today with partners in North America, Europe, Asia and South America, we continually work to improve and grow the company. We strive to offer customers exceptional value through our qualified local sales and service representatives who provide convenient access to over 5,000 globally sourced products.

---

Depuis 1951 Omcan a grandi pour devenir un des “leaders” de la distribution des équipements et matériel pour l’industrie des services alimentaires en Amérique du Nord. Notre succès au cours de ces nombreuses années peut être attribué à notre engagement à renforcer et à développer de nouvelles et existantes relations avec nos clients et les fabricants de valeur. Aujourd’hui avec des partenaires en Amérique du Nord, Europe, Asie et Amérique du Sud, nous travaillons continuellement à améliorer et développer l’entreprise. Nous nous efforçons d’offrir à nos clients une valeur exceptionnelle grâce à nos ventes locales qualifiées et des représentants de service qui offrent un accès facile à plus de 5000 produits provenant du monde entier.

---

Desde 1951 Omcan ha crecido hasta convertirse en un líder en la distribución de equipos y suministros de alimentos en América del Norte industria de servicios. Nuestro éxito en estos años se puede atribuir a nuestro compromiso de fortalecer y desarrollar nuevas relaciones existentes con nuestros valiosos clientes y fabricantes. Hoy con socios de América del Norte, Europa, Asia y América del Sur, que trabajan continuamente para mejorar y crecer la empresa. Nos esforzamos por ofrecer a nuestros clientes valor excepcional a través de nuestro local de ventas y representantes de los servicios que proporcionan un fácil acceso a más de 5,000 productos con origen a nivel mundial.

