



Convection Ovens
 Models CE-CN-0021, 0047, 0066
 Items 43217*, 43218+, 45599♦
Instruction Manual



STOP
DO NOT RETURN
THIS PRODUCT TO THE STORE
 For questions or assistance with this product call OMCAN Toll Free:
 1 800 465 0234
 Customer Service
 or
 visit the Support section of
 www.omcan.com

Revised - 03/11/2020



Toll Free: 1-800-465-0234
 Fax: 905-607-0234
 Email: service@omcan.com
www.omcan.com



<p>NEMA 5 - 15 125 VAC / 15 AMP RECEPTACLE</p>	
<p>NEMA 5 - 20 125 VAC / 20 AMP RECEPTACLE</p>	
<p>NEMA 6 - 20 250 VAC / 20 AMP RECEPTACLE</p>	

Table of Contents

Model CE-CN-0021 / Model CE-CN-0047 / Model CE-CN-0066

Section	Page
General Information -----	3 - 4
Safety and Warranty -----	4 - 6
Technical Specifications -----	6
Operation -----	7 - 8
Maintenance -----	8
Troubleshooting -----	9
Parts Breakdown -----	10 - 12
Electrical Schematics -----	13
Notes -----	14
Warranty Registration -----	15



General Information

Omcan Manufacturing and Distributing Company Inc., Food Machinery of America, Inc. dba Omcan and Omcan Inc. are not responsible for any harm or injury caused due to any person's improper or negligent use of this equipment. The product shall only be operated by someone over the age of 18, of sound mind, and not under the influence of any drugs or alcohol, who has been trained in the correct operation of this machine, and is wearing authorized, proper safety clothing. Any modification to the machine voids any warranty, and may cause harm to individuals using the machine or in the vicinity of the machine while in operation.

CHECK PACKAGE UPON ARRIVAL

Upon receipt of an Omcan shipment please inspect for external damage. If no damage is evident on the external packaging, open carton to ensure all ordered items are within the box, and there is no concealed damage to the machine. If the package has suffered rough handling, bumps or damage (visible or concealed), please note it on the bill of lading before accepting the delivery and contact Omcan within 24 hours, so we may initiate a claim with the carrier. A detailed report on the extent of the damage caused to the machine must be filled out within three days, from the delivery date shown in the shipping documents. Omcan has no recourse for damaged products that were shipped collect or third party.

Before operating any equipment, always read and familiarize yourself with all operation and safety instructions.

Omcan would like to thank you for purchasing this machine. It's of the utmost importance to save these instructions for future reference. Also save the original box and packaging for shipping the equipment if servicing or returning of the machine is required.

Omcan Fabrication et distribution Compañie Limité et Food Machinery d'Amerique, dba Omcan et Omcan Inc. ne sont pas responsables de tout dommage ou blessure causé du fait que toute personne ait utilisé cet équipement de façon irrégulière. Le produit ne doit être exploité que par quelqu'un de plus de 18 ans, saine d'esprit, et pas sous l'influence d'une drogue ou d'acohol, qui a été formé pour utiliser cette machine correctement, et est vêtu de vêtements de sécurité approprié. Toute modification de la machine annule toute garantie, et peut causer un préjudice à des personnes utilisant la machine ou des personnes à proximité de la machine pendant son fonctionnement.

VÉRIFIEZ LE COLIS DÈS RÉCEPTION

Dès réception d'une expédition d'Omcan veuillez inspecter pour dommages externes. Si aucun dommage n'est visible sur l'emballage externe, ouvrez le carton afin de s'assurer que tous les éléments commandés sont dans la boîte, et il n'y a aucun dommage dissimulé à la machine. Si le colis n'a subi aucune mauvaises manipulations, de bosses ou de dommages (visible ou cachée), notez-le sur le bond de livraison avant d'accepter la livraison et contactez Omcan dans les 24 heures qui suivent, pour que nous puissions engager une réclamation auprès du transporteur. Un rapport détaillé sur l'étendue des dommages causés à la machine doit être rempli dans un délai de trois jours, à compter de la date de livraison indiquée dans les documents d'expédition. Omcan n'a aucun droit de recours pour les produits endommagés qui ont été expédiées ou cueilli par un tiers transporteur.

General Information

Avant d'utiliser n'importe quel équipement, toujours lire et vous familiariser avec toutes les opérations et les consignes de sécurité.

Omcan voudrais vous remercier d'avoir choisi cette machine. Il est primordial de conserver ces instructions pour une référence ultérieure. Également conservez la boîte originale et l'emballage pour l'expédition de l'équipement si l'entretien ou le retour de la machine est nécessaire.

Omcan Empresa De Fabricacion Y Distribucion Inc. Y Maquinaria De Alimentos De America, Inc. dba Omcan y Omcan Inc. no son responsables de ningun daño o perjuicio causado por cualquier persona inadecuada o el uso descuidado de este equipo. El producto solo podra ser operado por una persona mayor de 18 años, en su sano juicio y no bajo alguna influencia de droga o alcohol, y que este ha sido entrenado en el correcto funcionamiento de esta máquina, y ésta usando ropa apropiada y autorizada. Cualquier modificación a la máquina anula la garantía y puede causar daños a las personas usando la máquina mientras esta en el funcionamiento.

REVISE EL PAQUETE A SU LLEGADA

Tras la recepcion de un envio Omcan favor inspeccionar daños externos. Si no hay daños evidentes en el empaque exterior, Habra el carton para asegurarse que todos los articulos solicitados estén dentro de la caja y no encuentre daños ocultos en la máquina. Si el paquete ha sufrido un manejo de poco cuidado, golpes o daños (visible o oculto) por favor anote en la factura antes de aceptar la entrega y contacte Omcan dentro de las 24 horas, de modo que podamos iniciar una reclamación con la compañía. Un informe detallado sobre los daños causados a la máquina debe ser llenado en el plazo de tres días, desde la fecha de entrega que se muestra en los documentos de envío. Omcan no tiene ningun recurso por productos dañados que se enviaron a recoger por terceros.

Antes de utilizar cualquier equipo, siempre leer y familiarizarse con todas las instrucciones de operación y seguridad.

Omcan quisiera darles las gracias por la compra de esta máquina. Es de la máxima importancia para guardar estas instrucciones para referencias en el futuro. También guarde la caja original y el embalaje para envío del equipo si el mantenimiento o la devolución de la máquina es necesaria.

Safety and Warranty

When using electrical appliances, basic safety precautions should always be followed, including the following:

1. READ ALL INFORMATION BEFORE USE.
2. For commercial use only.
3. Do not touch hot surfaces.
4. Protect against electrical shock by keeping all cords, plugs, and other electrical components away from water or other liquids.
5. Unplug this unit when not in use and before cleaning.



Safety and Warranty

6. Allow the unit to cool before putting on or taking off parts.
7. Do not operate this or any appliance with a damaged electrical cord or plug.
8. Do not operate this or any appliance after it has malfunctioned or been damaged in any way.
9. Do not use outdoors.
10. Do not place on or near a hot gas or electric burner.
11. Attach plug to appliance first, then plug electrical cord into the wall outlet.
12. Disconnect the unit by turning the temperature and timer control to "OFF" and "0", then removing the electrical plug from the wall outlet.
13. Do not use appliance for any application other than intended use.
14. Do not insert metal utensils or oversized foods into this unit as they may cause a fire and heighten the risk of electrical shock.
15. Do not store any item on top of this unit when in operation.
16. Do not allow this oven to touch or be covered by flammable material, such as curtains, draperies, walls, etc., when in operation.
17. Do not clean with metal scouring pads as pieces can break off and touch electrical components, heightening the risk of electrical shock.
18. Never place materials such as paper, cardboard, plastic, etc. in this oven.
19. Do not cover interior of this unit with metal foil as it may cause the oven to overheat.
20. Avoid scratching the surface or nicking the edges of this unit's tempered, safety glass door. If the oven door has a scratch or nick, contact customer service before use.
21. Turn the appliance off by turning the temperature and timer control to the "OFF" and "0" position.
22. Note that the use of accessories not recommended by the manufacturer may result in injury.
23. This appliance can be used by children aged from 8 years old and above and persons with reduced physical, sensory or mental capabilities or lack of experience and knowledge if they have been given supervision or instruction concerning use of the appliance in a safe way and understand the hazards involved. Children shall not play with the appliance. Cleaning and user maintenance shall not be made by children without supervision.
24. If the supply cord is damaged, it must be replaced by the manufacturer, its service agent or similarly qualified persons in order to avoid a hazard. The bread may burn, therefore do not use the toaster near or below combustible material, such as curtains.
25. When using the appliance in shops, snack bars, hotels etc., check the voltage and outlet to make sure the appliance is correctly connected with power.
26. Place unit on a flat surface that is well ventilated. The appliances must be supervised during operation, DO NOT leave appliance without powering off.
27. The connector must be removed before the appliance is cleaned and that the appliance inlet must be dried before the appliance is used again.
28. The door or outer surface may get hot when the appliance is operating.

1 YEAR PARTS AND LABOR BENCH WARRANTY

Within the warranty period, contact Omcan Inc. at 1-800-465-0234 to schedule an Omcan authorized service technician to repair the equipment locally.

Unauthorized maintenance will void the warranty. Warranty covers electrical and part failures, not improper use.

Safety and Warranty

Please see <https://omcan.com/disclaimer> for complete info.

WARNING:

The packaging components are classified as normal solid urban waste and can therefore be disposed of without difficulty.

In any case, for suitable recycling, we suggest disposing of the products separately (differentiated waste) according to the current norms.

DO NOT DISCARD ANY PACKAGING MATERIALS IN THE ENVIRONMENT!

Technical Specifications

Model	CE-CN-0021	CE-CN-0047	CE-CN-0066
Power	1440 W	1600 W	2800 W
Number of Racks	3	4	
Pans Size*	1/4 13" x 9" / 330 x 230mm	1/2 18" x 13" / 460 x 330mm	
Temperature Range	65 - 250°C / 150 - 500°F		
Capacity	21 L / 0.74 cu.ft	47 L / 1.66 cu.ft	66 L / 2.3 cu.ft
Electrical	120V / 60Hz / 1		220V / 60Hz / 1
Adjustable Timer	0 - 120 minutes		
Weight	32.4 lbs. / 14.7 kgs.	43.4 lbs. / 19.7 kgs.	52 lbs. / 23.6 kgs.
Packaging Weight	37 lbs. / 16.8 kgs.	49 lbs. / 22.3 kgs.	59.5 lbs. / 27 kgs.
Dimensions	18.7" x 20" x 15" 475 x 503 x 380mm	22.8" x 22.4" x 16" 580 x 570 x 406mm	22.8" x 22" x 20" 580 x 570 x 510mm
Packaging Dimensions	22" x 22" x 18" 565 x 565 x 455mm	26" x 26" x 18" 650 x 650 x 465mm	23.6" x 25.6" x 22.8" 600 x 650 x 580mm
Item Number	43217	43218	45599

*Pans not included.



Operation

BEFORE USING YOUR OVEN

Before cooking anything in your oven for the first time, please follow these simple instructions:

Using a small amount of detergent, wash the handle and roasting racks with soapy water. (NOTE: Do not use a spray or abrasive polishing agent.) Gently wipe down interior walls with a damp cloth. While washing this unit, do not touch the electric heating element. Do not soak the inside of the oven with water.

After washing and thoroughly drying the surfaces noted above, place the roasting racks back inside the oven. Close the oven door and preheat the oven to its highest temperature setting for 5 minutes.

Turn off the heating elements and open the oven door in order to remove any smoky residue from inside the oven. The heating elements are well lubricated and this initial use will help burn off the extra grease. A light amount of smoke is normal during this process.

USING YOUR OVEN

To start your oven, you need to turn on the temperature dial to set your desired cooking temperature, and turn on the timer dial to set the cooking time.

This appliance is intended to be operated by means of an external timer or separate remote-control system.

CAUTION: During the baking process, make sure that no metal accessory comes in contact with the electric heating elements.

CAUTION: Foods baked in this oven will be hot. Wear protective hand coverings when reaching into oven to retrieve food.

TYPICAL OPERATION SEQUENCE

ACTION	RESULT
Plug in your oven.	Power is connected but power light will go on after turning the temperature dial.
Adjust temperature control knob.	Heating indicator light comes on; heating elements begin to heat up.
Temperature light shuts off.	Oven has reached desired temperature.
Load product into oven.	Product will begin to cook.
Set timer to desired cook time between 0-120 min.	Timer starts timing down.
Timer reaches zero.	Timer chimes.
Unload oven.	Product will be cooked/hot; use caution removing it from the oven.

TIMER

The range of the timer on this unit is 0-120 minutes. Turning the timer to the "0" position, the cooking time is

Operation

over and the timer will “ding” to alert.

If you need to reset the baking time while the oven is in operation, simply turn the timer to a new position. The oven will reset the time according to the revised requirement without needing to be turned off.

When the set baking time has been reached, the oven will chime.

TEMPERATURE CONTROL KNOB

The temperature range of this unit is 150 - 500 Fahrenheit Degree for all models. This thermostatic switch controls the temperature inside the oven and helps to maintain the proper temperature during various heating, roasting, and baking applications.

POWER AND TEMPERATURE INDICATOR LIGHT

Anytime this appliance is connected to the power supply with the temperature knob turned on, the power and heating indicator light will be on and the fan motor will begin to operate.

PROTECTION COMPONENT

If the temperature of this oven reaches an unsafe limit, the electrical components will shut off and it will stop operating in order to prevent overheating.

Maintenance

CLEANING AND MAINTAINING YOUR OVEN

To clean, first remove the power cord’s plug from the wall outlet. Wait for the oven to cool. Use a damp cloth or sponge to gently wipe down the inside of the oven. Avoid soaking the inside of the oven or washing it in running water as this will cause serious damage to the unit.

The food racks and food trays are good for dish washer machine, or just clean with soft cloth after every use, then clean with dry cloth before putting back into the oven.



Troubleshooting

Problem	Possible Solutions
The oven does not become hot after being switched on.	Be sure that the timer switch is set.
	Be sure that the temperature control knob is set.
There is a metallic sound when the oven is in use.	Do not attempt to dismantle the oven.
	Contact your service agent right away to examine the fan.
Food is often overcooked or burned, even when cooked according to the recipe.	Check that the fan motor is operating normally.
	Contact your service agent to examine the temperature control knob.

REFERENCE

Item Number	Model Number	Description	Manufacturer Model Number
43217	CE-CN-0021	Convection Oven 120V/60Hz/1Ph 1.44kW with 3 Chrome Shelf Manual Control cETLus / ETL Sanitation	FD-21
43218	CE-CN-0047	Convection Oven 120V/60Hz/1Ph 1.6kW with 4 Chrome Shelf Manual Control cETLus / ETL Sanitation	FD-47
45599	CE-CN-0066	Convection Oven 220V/60Hz/1Ph 2.88kW with 4 Chrome Shelf Manual Control cETLus / ETL Sanitation	FD-66B

Parts Breakdown

Model CE-CN-0021 43217

Model CE-CN-0047 43218

Model CE-CN-0066 45599

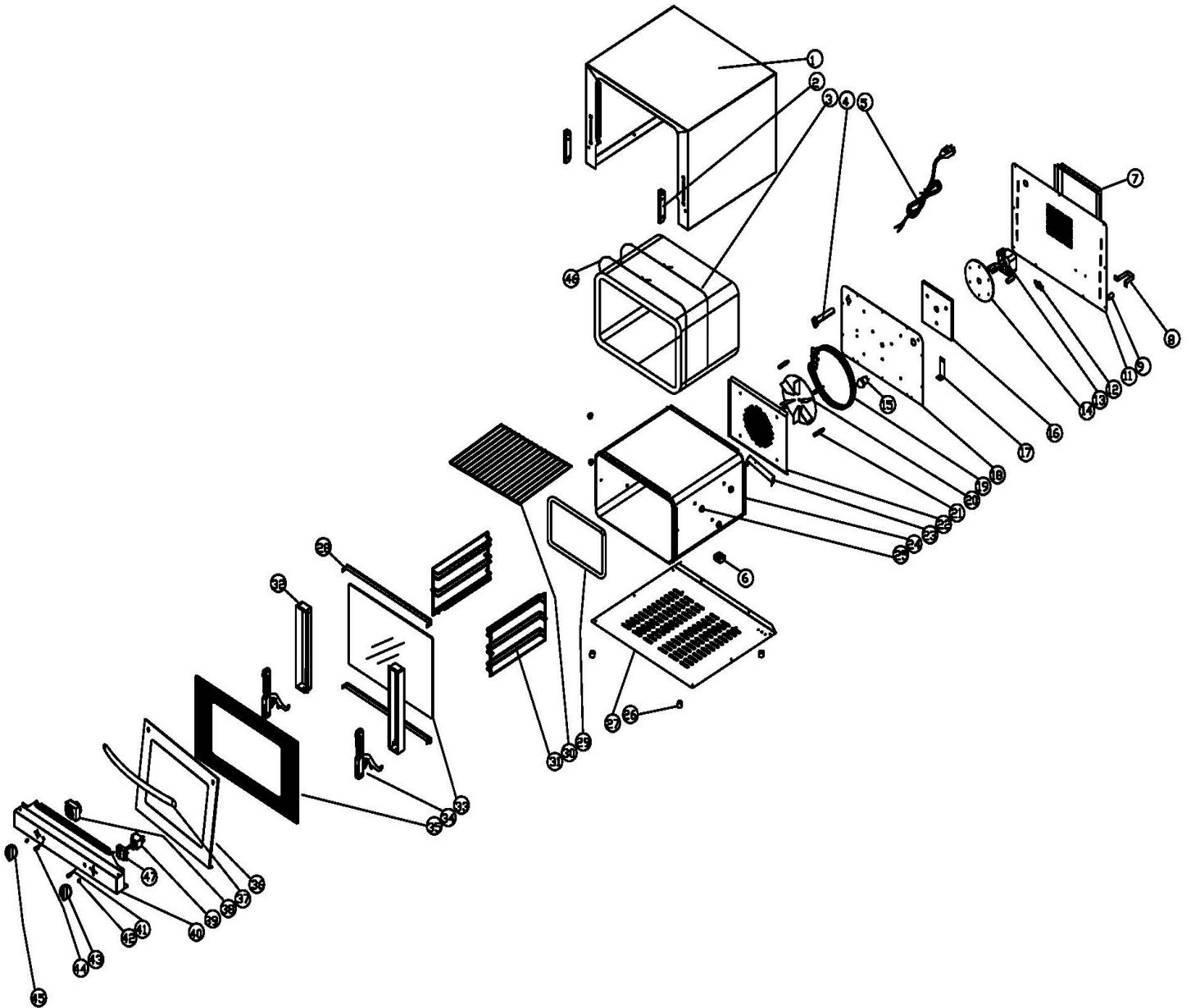



Parts Breakdown

Model CE-CN-0021 43217

Item No.	Description	Position	Item No.	Description	Position	Item No.	Description	Position
62243	Shell for FD-21	1	62256	Connection Plate for FD-21	17	62270	Tray Grid for FD-21	31
62244	Hinge Wheels for FD-21	2	62257	Middle Board for FD-21	18	62271	Left and Right Door Trim for FD-21	32
62245	Insulation for FD-21	3	62258	Heating Element for FD-21	19	62272	Inner Glass for FD-21	33
62246	Exhaust Pipe for FD-21	4	62259	Fan Blade for FD-21	20	62273	Hinge Assembly for FD-21	34
62247	Power Cord for FD-21	5	62260	Connection Pole for FD-21	21	62274	Outer Glass for FD-21	35
62248	Terminal for FD-21	6	62261	Wind Board for FD-21	22	62275	Front Door Frame for FD-21	36
66166	Heat Insulation Board for FD-21	7	62262	Sensor Fixture for FD-21	23	62276	Handle for FD-21	37
62249	Space Holder for FD-21	8	62263	Interior for FD-21	24	62278	Thermostat for FD-21	39
62250	Wire Buckle for FD-21	9	62264	Grid Screws for FD-21	25	62279	Control Panel for FD-21	40
62251	Rear Board for FD-21	11	62265	Feet for FD-21	26	62280	Heating Light for FD-21	41, 44
62252	Temperature Cut-Out for FD-21	12, 38	62266	Bottom Board for FD-21	27	62281	Knob Spring Plate for FD-21	42
62253	Motor for FD-21	13	62267	Up and Bottom Door Clip for FD-21	28	62282	Thermostat Knob for FD-21	43, 45
62254	Motor Base for FD-21	14	62268	Door Seal for FD-21	29	62285	Insulation Ties for FD-21	46
62255	Motor Insulation for FD-21	16	62269	Tray for FD-21	30	62286	Switch for FD-21	47

Model CE-CN-0047 43218

Item No.	Description	Position	Item No.	Description	Position	Item No.	Description	Position
62287	Shell for FD-47	1	62256	Connection Plate for FD-47	17	62298	Tray Grid for FD-47	31
62288	Hinge Wheels for FD-47	2	62292	Middle Board for FD-47	18	62299	Left and Right Door Trim for FD-47	32
62289	Insulation for FD-47	3	62293	Heating Element for FD-47	19	62300	Inner Glass for FD-47	33
62246	Exhaust Pipe for FD-47	4	62259	Fan Blade for FD-47	20	62301	Hinge Assembly for FD-47	34
62290	Power Cord for FD-47	5	62260	Connection Pole for FD-47	21	62302	Outer Glass for FD-47	35
62248	Terminal for FD-47	6	62261	Wind Board for FD-47	22	62303	Front Door Frame for FD-47	36
66166	Heat Insulation Board for FD-47	7	62262	Sensor Fixture for FD-47	23	66169	Handle for FD-47	37
62249	Space Holder for FD-47	8	62295	Interior for FD-47	24	62278	Thermostat for FD-47	39
62250	Wire Buckle for FD-47	9	62264	Grid Screws for FD-47	25	62304	Control Panel for FD-47	40
62291	Rear Board for FD-47	11	62265	Feet for FD-47	26	62280	Heating Light for FD-47	41, 44
62252	Temperature Cut-Out for FD-47	12, 38	62296	Bottom Board for FD-47	27	62281	Knob Spring Plate for FD-47	42
62253	Motor for FD-47	13	66167	Up and Bottom Door Clip for FD-47	28	62282	Thermostat Knob for FD-47	43, 45
62254	Motor Base for FD-47	14	62297	Door Seal for FD-47	29	62285	Insulation Ties for FD-47	46
62255	Motor Insulation for FD-47	16	66168	Tray for FD-47	30	62286	Switch for FD-47	47

Parts Breakdown

Model CE-CN-0066 45599

Item No.	Description	Position	Item No.	Description	Position	Item No.	Description	Position
63901	Shell for FD-66B	1	62256	Connection Plate for FD-66B	17	62298	Tray Grid for FD-66B	31
63902	Hinge Wheels for FD-66B	2	63915	Middle Board for FD-66B	18	63929	Left and Right Door Trim for FD-66B	32
63903	Insulation for FD-66B	3	63916	Heating Element for FD-66B	19	63930	Inner Glass for FD-66B	33, 35
62246	Exhaust Pipe for FD-66B	4	62259	Fan Blade for FD-66B	20	63931	Hinge Assembly for FD-66B	34
63905	Power Cord for FD-66B	5	63918	Connection Pole for FD-66B	21	63933	Front Door Frame for FD-66B	36
62248	Terminal for FD-66B	6	62261	Wind Board for FD-66B	22	66169	Handle for FD-66B	37
66166	Heat Insulation Board for FD-66B	7	62262	Sensor Fixture for FD-66B	23	62278	Thermostat for FD-66B	39
62249	Space Holder for FD-66B	8	63921	Interior for FD-66B	24	62304	Control Panel for FD-66B	40
62250	Wire Buckle for FD-66B	9	62264	Grid Screws for FD-66B	25	63938	Heating Light for FD-66B	41, 44
63909	Rear Board for FD-66B	11	62265	Feet for FD-66B	26	62281	Knob Spring Plate for FD-66B	42
62252	Temperature Cut-Out for FD-66B	12, 38	63924	Bottom Board for FD-66B	27	62282	Thermostat Knob for FD-66B	43, 45
63911	Motor for FD-66B	13	66167	Up and Bottom Door Clip for FD-66B	28	62285	Insulation Ties for FD-66B	46
62254	Motor Base for FD-66B	14	63926	Door Seal for FD-66B	29	62286	Switch for FD-66B	47
62255	Motor Insulation for FD-66B	16	66168	Tray for FD-66B	30			

Electrical Schematics

Model CE-CN-0021 43217

Model CE-CN-0047 43218

Model CE-CN-0066 45599

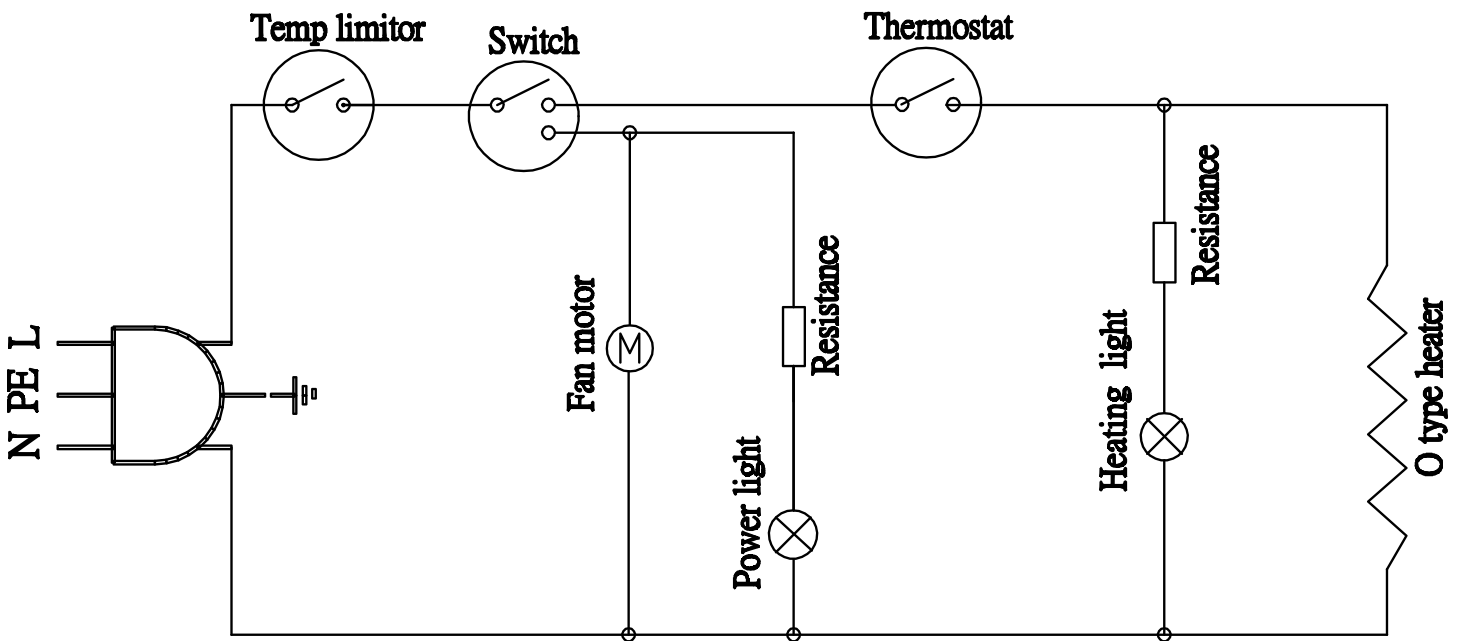



Warranty Registration

Thank you for purchasing an Omcan product. To register your warranty for this product, complete the information below, tear off the card at the perforation and then send to the address specified below. You can also register online by visiting:

Merci d'avoir acheté un produit Omcan. Pour enregistrer votre garantie pour ce produit, complétez les informations ci-dessous, détachez la carte au niveau de la perforation, puis l'envoyer à l'adresse spécifiée ci-dessous. Vous pouvez également vous inscrire en ligne en visitant:

Gracias por comprar un producto Omcan usted. Para registrar su garantía para este producto, complete la información a continuación, cortar la tarjeta en la perforación y luego enviarlo a la dirección indicada a continuación. También puede registrarse en línea en:

<https://omcan.com/warranty-registration/>

For mailing in Canada

Pour postale au Canada

Por correo en Canadá

OMCAN

PRODUCT WARRANTY REGISTRATION

3115 Pepper Mill Court,

Mississauga, Ontario

Canada, L5L 4X5

For mailing in the US

Pour diffusion aux États-Unis

Por correo en los EE.UU.

OMCAN

PRODUCT WARRANTY REGISTRATION

4450 Witmer Industrial Estates, Unit 4,

Niagara Falls, New York

USA, 14305

or email to: service@omcan.com



Purchaser's Information

Name: _____

Address: _____

City: _____ Province or State: _____ Postal or Zip: _____

Country: _____

Dealer from which Purchased: _____

Dealer City: _____ Dealer Province or State: _____

Invoice: _____

Model Name: _____ Model Number: _____

Machine Description: _____

Date of Purchase (MM/DD/YYYY): _____

Would you like to extend the warranty? Yes No

Company Name: _____

Telephone: _____

Email Address: _____

Type of Company:

Restaurant Bakery Deli

Butcher Supermarket Caterer

Institution (*specify*): _____

Other (*specify*): _____

Serial Number: _____

Date of Installation (MM/DD/YYYY): _____

Thank you for choosing Omcan | Merci d'avoir choisi Omcan | Gracias por elegir Omcan



Since 1951 Omcan has grown to become a leading distributor of equipment and supplies to the North American food service industry. Our success over these many years can be attributed to our commitment to strengthen and develop new and existing relationships with our valued customers and manufacturers. Today with partners in North America, Europe, Asia and South America, we continually work to improve and grow the company. We strive to offer customers exceptional value through our qualified local sales and service representatives who provide convenient access to over 5,000 globally sourced products.

Depuis 1951 Omcan a grandi pour devenir un des “leaders” de la distribution des équipements et matériel pour l’industrie des services alimentaires en Amérique du Nord. Notre succès au cours de ces nombreuses années peut être attribué à notre engagement à renforcer et à développer de nouvelles et existantes relations avec nos clients et les fabricants de valeur. Aujourd’hui avec des partenaires en Amérique du Nord, Europe, Asie et Amérique du Sud, nous travaillons continuellement à améliorer et développer l’entreprise. Nous nous efforçons d’offrir à nos clients une valeur exceptionnelle grâce à nos ventes locales qualifiées et des représentants de service qui offrent un accès facile à plus de 5000 produits provenant du monde entier.

Desde 1951 Omcan ha crecido hasta convertirse en un líder en la distribución de equipos y suministros de alimentos en América del Norte industria de servicios. Nuestro éxito en estos años se puede atribuir a nuestro compromiso de fortalecer y desarrollar nuevas relaciones existentes con nuestros valiosos clientes y fabricantes. Hoy con socios de América del Norte, Europa, Asia y América del Sur, que trabajan continuamente para mejorar y crecer la empresa. Nos esforzamos por ofrecer a nuestros clientes valor excepcional a través de nuestro local de ventas y representantes de los servicios que proporcionan un fácil acceso a más de 5,000 productos con origen a nivel mundial.

