



**Electric Griddles**  
Models CE-CN-3000, 4400  
Items 34869, \*34870  
**Instruction Manual**



*Revised - 01/27/2020*



Toll Free: 1-800-465-0234  
Fax: 905-607-0234  
Email: [service@omcan.com](mailto:service@omcan.com)  
[www.omcan.com](http://www.omcan.com)

*\*Power cord and plug not included; must be installed by a certified electrician*

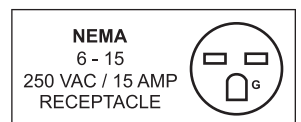

# ***Table of Contents***

Model CE-CN-3000 / Model CE-CN-4400

---

<b>Section</b>	<b>Page</b>
General Information -----	3 - 4
Safety and Warranty -----	4 - 5
Technical Specifications -----	6
Operation -----	6
Maintenance -----	6 - 7
Parts Breakdown -----	7 - 9
Electrical Schematics -----	10 - 11
Notes -----	12 - 14
Warranty Registration -----	15



# General Information

---

Omcan Manufacturing and Distributing Company Inc., Food Machinery of America, Inc. dba Omcan and Omcan Inc. are not responsible for any harm or injury caused due to any person's improper or negligent use of this equipment. The product shall only be operated by someone over the age of 18, of sound mind, and not under the influence of any drugs or alcohol, who has been trained in the correct operation of this machine, and is wearing authorized, proper safety clothing. Any modification to the machine voids any warranty, and may cause harm to individuals using the machine or in the vicinity of the machine while in operation.

## CHECK PACKAGE UPON ARRIVAL

Upon receipt of an Omcan shipment please inspect for external damage. If no damage is evident on the external packaging, open carton to ensure all ordered items are within the box, and there is no concealed damage to the machine. If the package has suffered rough handling, bumps or damage (visible or concealed), please note it on the bill of lading before accepting the delivery and contact Omcan within 24 hours, so we may initiate a claim with the carrier. A detailed report on the extent of the damage caused to the machine must be filled out within three days, from the delivery date shown in the shipping documents. Omcan has no recourse for damaged products that were shipped collect or third party.

**Before operating any equipment, always read and familiarize yourself with all operation and safety instructions.**

Omcan would like to thank you for purchasing this machine. It's of the utmost importance to save these instructions for future reference. Also save the original box and packaging for shipping the equipment if servicing or returning of the machine is required.

---

Omcan Fabrication et distribution Compañie Limité et Food Machinery d'Amérique, dba Omcan et Omcan Inc. ne sont pas responsables de tout dommage ou blessure causé du fait que toute personne ait utilisé cet équipement de façon irrégulière. Le produit ne doit être exploité que par quelqu'un de plus de 18 ans, saine d'esprit, et pas sous l'influence d'une drogue ou d'alcool, qui a été formé pour utiliser cette machine correctement, et est vêtu de vêtements de sécurité approprié. Toute modification de la machine annule toute garantie, et peut causer un préjudice à des personnes utilisant la machine ou des personnes à proximité de la machine pendant son fonctionnement.

## VÉRIFIEZ LE COLIS DÈS RÉCEPTION

Dès réception d'une expédition d'Omcan veuillez inspecter pour dommages externes. Si aucun dommage n'est visible sur l'emballage externe, ouvrez le carton afin de s'assurer que tous les éléments commandés sont dans la boîte, et il n'y a aucun dommage dissimulé à la machine. Si le colis n'a subi aucune mauvaises manipulations, de bosses ou de dommages (visible ou cachée), notez-le sur le bond de livraison avant d'accepter la livraison et contactez Omcan dans les 24 heures qui suivent, pour que nous puissions engager une réclamation auprès du transporteur. Un rapport détaillé sur l'étendue des dommages causés à la machine doit être rempli dans un délai de trois jours, à compter de la date de livraison indiquée dans les documents d'expédition. Omcan n'a aucun droit de recours pour les produits endommagés qui ont été expédiés ou cueilli par un tiers transporteur.

# General Information

---

Avant d'utiliser n'importe quel équipement, toujours lire et vous familiariser avec toutes les opérations et les consignes de sécurité.

Omcan voudrais vous remercier d'avoir choisi cette machine. Il est primordial de conserver ces instructions pour une référence ultérieure. Également conservez la boîte originale et l'emballage pour l'expédition de l'équipement si l'entretien ou le retour de la machine est nécessaire.

---

Omcan Empresa De Fabricacion Y Distribucion Inc. Y Maquinaria De Alimentos De America, Inc. dba Omcan y Omcan Inc. no son responsables de ningun daño o perjuicio causado por cualquier persona inadecuada o el uso descuidado de este equipo. El producto solo podra ser operado por una persona mayor de 18 años, en su sano juicio y no bajo alguna influencia de droga o alcohol, y que este ha sido entrenado en el correcto funcionamiento de esta máquina, y ésta usando ropa apropiada y autorizada. Cualquier modificación a la máquina anula la garantía y puede causar daños a las personas usando la máquina mientras esta en el funcionamiento.

## REVISE EL PAQUETE A SU LLEGADA

Tras la recepcion de un envio Omcan favor inspeccionar daños externos. Si no hay daños evidentes en el empaque exterior, Habra el carton para asegurarse que todos los articulos solicitados estén dentro de la caja y no encuentre daños ocultos en la máquina. Si el paquete ha sufrido un manejo de poco cuidado, golpes o daños (visible o oculto) por favor anote en la factura antes de aceptar la entrega y contacte Omcan dentro de las 24 horas, de modo que podamos iniciar una reclamación con la compañía. Un informe detallado sobre los daños causados a la máquina debe ser llenado en el plazo de tres días, desde la fecha de entrega que se muestra en los documentos de envío. Omcan no tiene ningun recurso por productos dañados que se enviaron a recoger por terceros.

Antes de utilizar cualquier equipo, siempre lea y familiarizarse con todas las instrucciones de funcionamiento y seguridad.

Omcan le gustaría darle las gracias por la compra de esta máquina. Es de la mayor importancia para salvar estas instrucciones para futuras consultas. Además, guarda la caja original y el embalaje para el envío del equipo si servicio técnico o devolución de la máquina que se requiere.

# Safety and Warranty

---

## CAUTION

Model CE-CN-4400 is shipped without a plug and power cord, for your safety, ensure that only a certified electrician installs the griddle.

- All operators must strictly observe the guidelines for safe use of electrical machines.
- The owner should assure only those who meet the following condition(s) are allowed to operate the equipment:

# *Safety and Warranty*

---

- Those specially trained and strictly adhere to operation rules.
- All operations should be carried out only in safe conditions. Any failure to do so can cause danger to yourself. Any defects should be repaired immediately by a qualified technician. Before operating the machine, all safety devices and removable parts should be inspected; and only after they have been tested, can the machine be operated. Prior to any maintenance or service, the machine must be powered off and unplugged; do not open the machine; all components must be installed in accordance with regulations, and by qualified technicians.
- Shut down and unplug the equipment and make sure the equipment has cooled down before any maintenance.
- Periodical maintenance checks should be implemented to ensure safe operation.
- Do not touch the hot surface when it is in operation.

## **Warning**

User must only use a dry towel and small amounts of mild cleaner and water to clean the machine. Flushing with water is prohibited, parts will become damp and influence the safe performance of the machine.

## **1 YEAR PARTS AND LABOUR BENCH WARRANTY**

**Within the warranty period, contact Omcan Inc. At 1-800-465-0234 to schedule a drop off to either an Omcan authorized service depot in the area, or to an Omcan Service warehouse to repair the equipment.**

**Unauthorized maintenance will void the warranty. Warranty covers electrical and part failures, not improper use.**

**Please see <https://omcan.com/disclaimer> for complete info.**

## **WARNING:**

The packaging components are classified as normal solid urban waste and can therefore be disposed of without difficulty.

**In any case, for suitable recycling, we suggest disposing of the products separately (differentiated waste) according to the current norms.**

**DO NOT DISCARD ANY PACKAGING MATERIALS IN THE ENVIRONMENT!**

# Technical Specifications

Model	CE-CN-3000	CE-CN-4400
Power	3 kW	4.4 kW
Temperature Range	0°C - 300°C / 32°F - 572°F	
Cooking Area	21.75" x 13.75" / 552 x 349mm	28.5" x 15.75" / 724 x 400mm
Electrical	220V / 60Hz / 1Ph	
Dimensions	17.75" x 21.75" x 9" / 451 x 552 x 229mm	19.75" x 28.75" x 9" / 502 x 730 x 229mm
Weight	50.75 lbs. / 23 kgs.	70.5 lbs. / 32 kgs.
Item Number	34869	34870

## Operation

1. Place the machine on a non-flammable, secure, level and safe surface, a minimum 4"/10cm from a wall or other object. Connect the power to the correct electrical output. The green indication light will turn on.
2. Adjust the working temperature to the desired setting. The working light will illuminate yellow, the heating plate is working. When the temperature reaches the desired level, the yellow light will turn off.
3. After testing the temperature, the user can re-adjust the thermostat knob, establishing the desired cooking temperature.
4. The user can start cooking on the grill. When the temperature lowers, the thermostat will engage and unit will start reheating automatically.
5. When the food is cooked, the user can remove it using a serving tool. Avoid using metal tools to remove the food, otherwise it will scratch and damage the surface of heating plate.
6. The small drip box at the bottom of the grill will collect the waste food and oil. It should be cleaned out frequently to avoid spillage or fire.

## Maintenance

### CLEANING

To maintain the appearance and increase the life of your griddle, clean and oil it daily. DO NOT clean equipment with steel wool.

1. Allow the equipment to cool completely before cleaning.
2. Using a wire brush, scrape the griddle plate to remove any food residue.
3. Do not clean the griddle plate with water, only scrape off food residue and lightly grease the plate with oil.
4. Empty and clean the drip box.

# Maintenance

## PROBLEMS AND SOLUTIONS

Problems	Reason	Solution
Switch is turned on but it is not heating.	Electric wire.	Check the wire.
	Electric contact.	Ensure electrical socket is working.
Temperature can't be controlled.	Wrong wire contacting.	Call Omcan.
	Temperature failure.	Call Omcan.

## REFERENCE

Item Number	Model Number	Description	Manufacturer Model Number
34869	CE-CN-3000	Griddle 22" x 14" / 552mm x 349mm 3000 W 220V/60/1 cQPSus	LS-818
34870	CE-CN-4400	Griddle 29" x 16" / 724mm x 400mm 4400 W 220V/60/1 cQPSus	LS-820

# Parts Breakdown

## Model CE-CN-3000 34869

Item No.	Description	Position	Item No.	Description	Position	Item No.	Description	Position
39774	Thermostat for LS-818	1	40038	Heater Cover for LS-818	7	40045	Bottom Cover for LS-818	16
44718	Power Indicator (Green) for LS-818	2-1	40039	Heater Fixed Stick for LS-818	8	40046	Rubber Feet for LS-818	17
40033	Power Indicator (Yellow) for LS-818	2-2	40040	Heater for LS-818	9	40047	Control Box Inner Cover for LS-818	18
39812	Grease Tray for LS-818	3	40041	Heating Plate Assembly for LS-818	10 - 12	40048	Control Box for LS-818	19
40035	Grease Tray Support for LS-818	4	40042	Power Cord for LS-818	13	40049	Control Box Bottom Cover for LS-818	20
40036	Frame for LS-818	5	40043	Terminal Box Cover for LS-818	14			
40037	Insulation Cover for LS-818	6	40044	Terminal Box for LS-818	15			

## Model CE-CN-4400 34870

Item No.	Description	Position	Item No.	Description	Position	Item No.	Description	Position
39774	Thermostat for LS-820	1	40052	Insulation Cover for LS-820	6	40044	Terminal Box for LS-820	15
44718	Power Indicator (Green) for LS-820	2-1	40053	Heater Cover for LS-820	7	40056	Bottom Cover for LS-820	16
40033	Power Indicator (Yellow) for LS-820	2-2	40054	Heater Fixed Stick for LS-820	8	40046	Rubber Feet for LS-820	17
39813	Grease Tray for LS-820	3	39852	Heater for LS-820	9	40057	Control Box Inner Cover for LS-820	18
40050	Grease Tray Support for LS-820	4	40055	Heating Plate Assembly for LS-820	10 - 12	40058	Control Box for LS-820	19
40051	Frame for LS-820	5	40043	Terminal Box Cover for LS-820	14	40059	Control Box Bottom Cover for LS-820	20

# Parts Breakdown

Model CE-CN-3000 34869

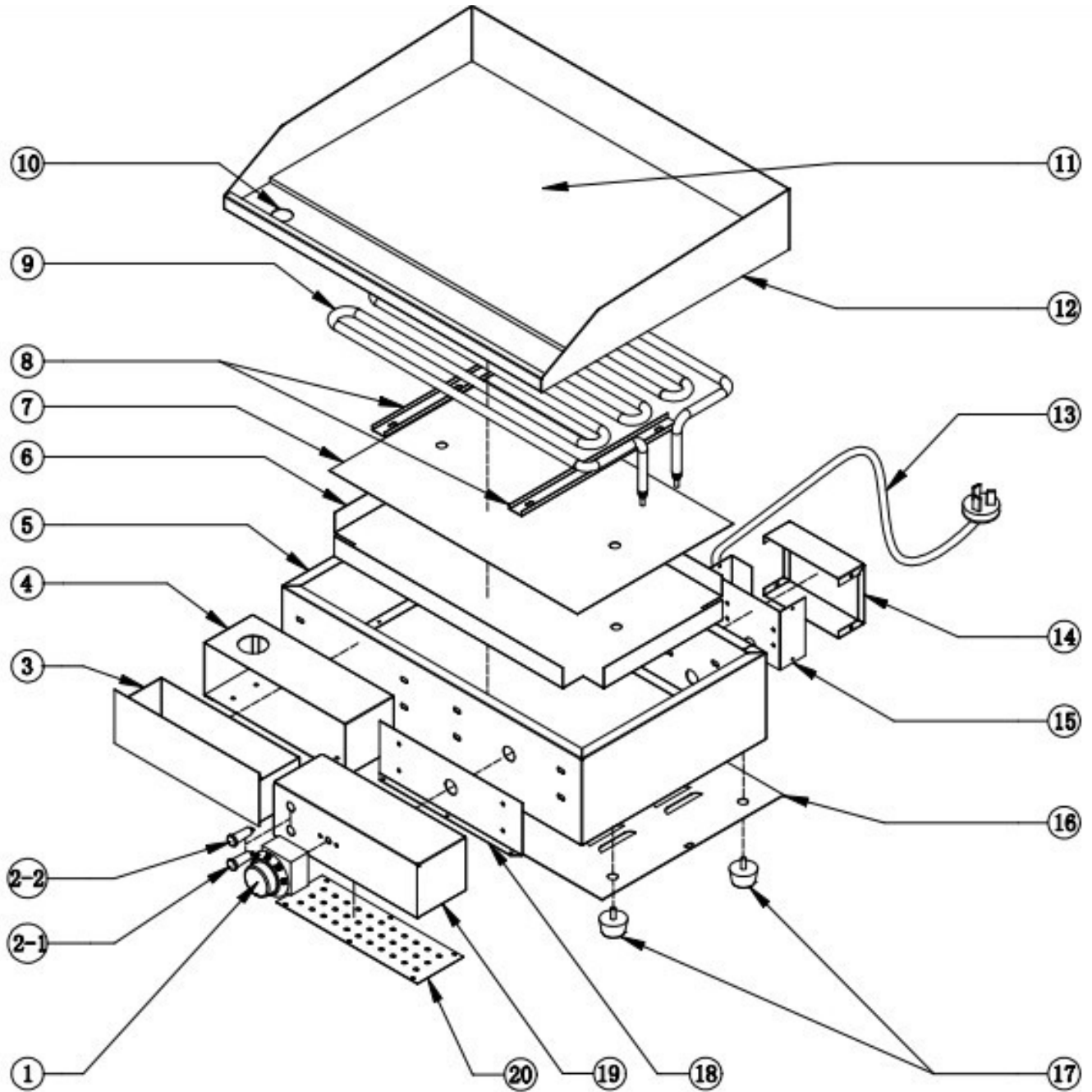

# Parts Breakdown

Model CE-CN-4400 34870

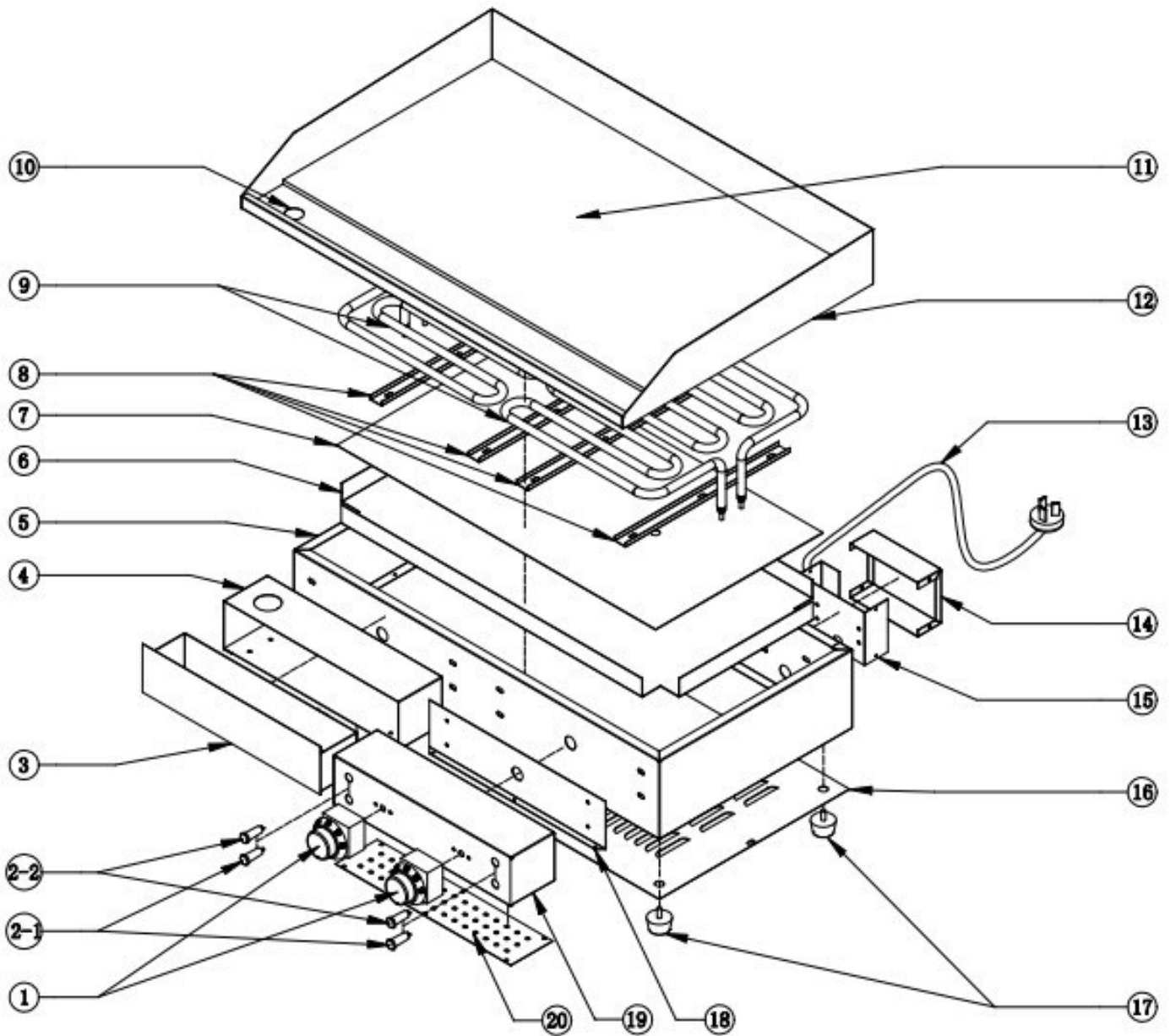

# Electrical Schematics

Model CE-CN-3000 34869

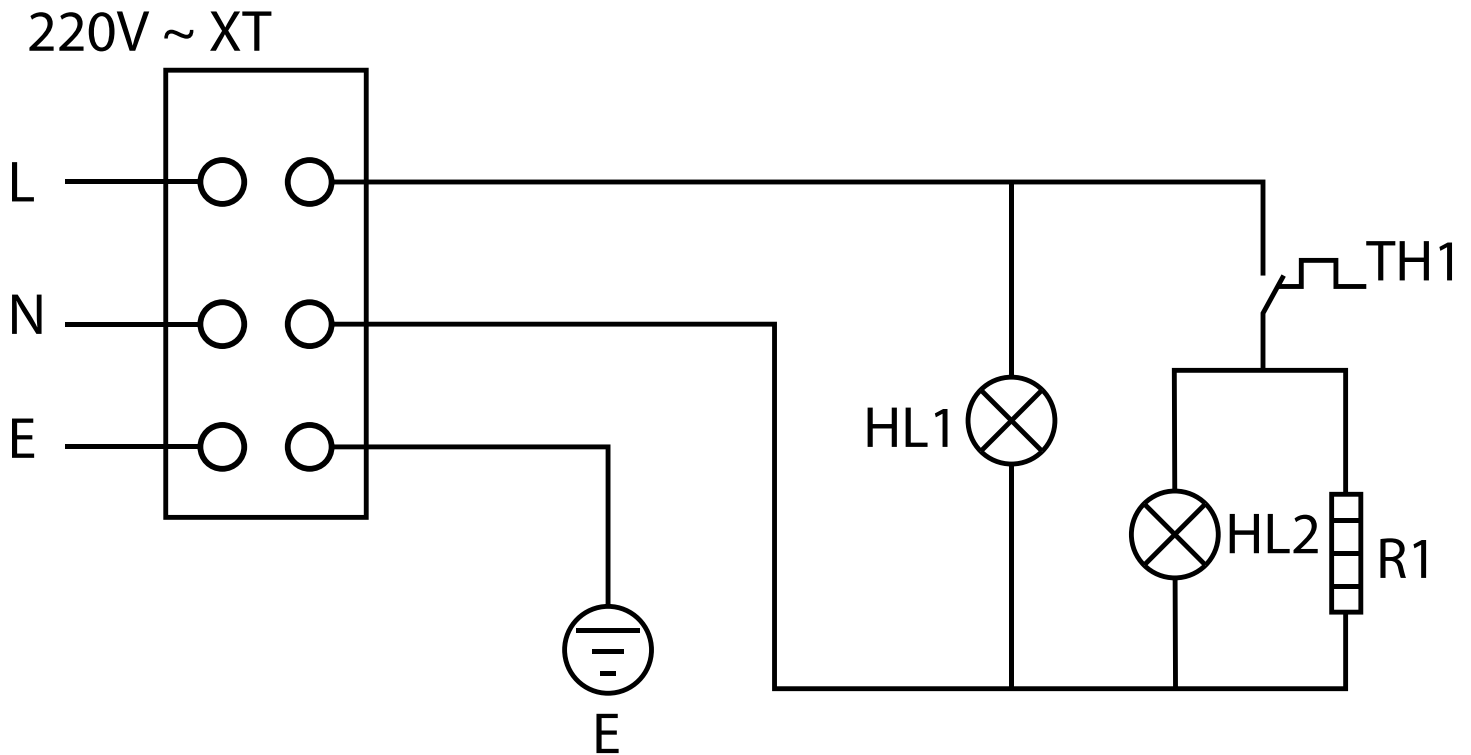

XT -- Terminal

R1 -- Heater

HL1, HL2 -- Indicator

TH1 -- Thermostat

# Electrical Schematics

**Model CE-CN-4400** 34870

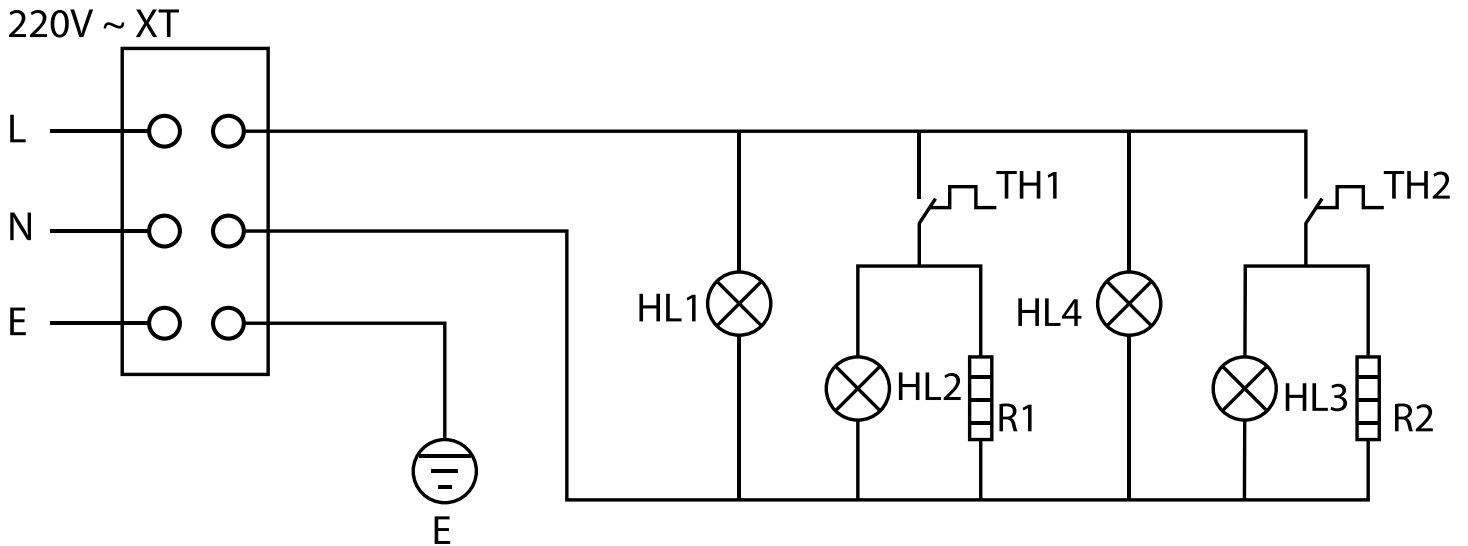

XT -- Terminal

R1, R2 -- Heater

HL1, HL2, HL3, HL4 -- Indicator

TH1, TH2 -- Thermostat









# Warranty Registration

Thank you for purchasing an Omcan product. To register your warranty for this product, complete the information below, tear off the card at the perforation and then send to the address specified below. You can also register online by visiting:

Merci d'avoir acheté un produit Omcan. Pour enregistrer votre garantie pour ce produit, complétez les informations ci-dessous, détachez la carte au niveau de la perforation, puis l'envoyer à l'adresse spécifiée ci-dessous. Vous pouvez également vous inscrire en ligne en visitant:

Gracias por comprar un producto Omcan usted. Para registrar su garantía para este producto, complete la información a continuación, cortar la tarjeta en la perforación y luego enviarlo a la dirección indicada a continuación. También puede registrarse en línea en:

<https://omcan.com/warranty-registration/>

**For mailing in Canada**

**Pour postale au Canada**

**Por correo en Canadá**

**For mailing in the US**

**Pour diffusion aux États-Unis**

**Por correo en los EE.UU.**

**OMCAN**

PRODUCT WARRANTY REGISTRATION

3115 Pepper Mill Court,

Mississauga, Ontario

Canada, L5L 4X5

**OMCAN**

PRODUCT WARRANTY REGISTRATION

4450 Witmer Industrial Estates, Unit 4,

Niagara Falls, New York

USA, 14305

**or email to: [service@omcan.com](mailto:service@omcan.com)**



**Purchaser's Information**

Name: \_\_\_\_\_

Address: \_\_\_\_\_

City: \_\_\_\_\_ Province or State: \_\_\_\_\_ Postal or Zip: \_\_\_\_\_

Country: \_\_\_\_\_

Dealer from which Purchased: \_\_\_\_\_

Dealer City: \_\_\_\_\_ Dealer Province or State: \_\_\_\_\_

Invoice: \_\_\_\_\_

Model Name: \_\_\_\_\_ Model Number: \_\_\_\_\_

Machine Description: \_\_\_\_\_

Date of Purchase (MM/DD/YYYY): \_\_\_\_\_

Would you like to extend the warranty?  Yes  No

Company Name: \_\_\_\_\_

Telephone: \_\_\_\_\_

Email Address: \_\_\_\_\_

Type of Company:

Restaurant  Bakery  Deli

Butcher  Supermarket  Caterer

Institution (specify): \_\_\_\_\_

Other (specify): \_\_\_\_\_

Serial Number: \_\_\_\_\_

Date of Installation (MM/DD/YYYY): \_\_\_\_\_

**Thank you for choosing Omcan | Merci d'avoir choisi Omcan | Gracias por elegir Omcan**



Since 1951 Omcan has grown to become a leading distributor of equipment and supplies to the North American food service industry. Our success over these many years can be attributed to our commitment to strengthen and develop new and existing relationships with our valued customers and manufacturers. Today with partners in North America, Europe, Asia and South America, we continually work to improve and grow the company. We strive to offer customers exceptional value through our qualified local sales and service representatives who provide convenient access to over 5,000 globally sourced products.

---

Depuis 1951 Omcan a grandi pour devenir un des “leaders” de la distribution des équipements et matériel pour l’industrie des services alimentaires en Amérique du Nord. Notre succès au cours de ces nombreuses années peut être attribué à notre engagement à renforcer et à développer de nouvelles et existantes relations avec nos clients et les fabricants de valeur. Aujourd’hui avec des partenaires en Amérique du Nord, Europe, Asie et Amérique du Sud, nous travaillons continuellement à améliorer et développer l’entreprise. Nous nous efforçons d’offrir à nos clients une valeur exceptionnelle grâce à nos ventes locales qualifiées et des représentants de service qui offrent un accès facile à plus de 5000 produits provenant du monde entier.

---

Desde 1951 Omcan ha crecido hasta convertirse en un líder en la distribución de equipos y suministros de alimentos en América del Norte industria de servicios. Nuestro éxito en estos años se puede atribuir a nuestro compromiso de fortalecer y desarrollar nuevas relaciones existentes con nuestros valiosos clientes y fabricantes. Hoy con socios de América del Norte, Europa, Asia y América del Sur, que trabajan continuamente para mejorar y crecer la empresa. Nos esforzamos por ofrecer a nuestros clientes valor excepcional a través de nuestro local de ventas y representantes de los servicios que proporcionan un fácil acceso a más de 5,000 productos con origen a nivel mundial.

