



Conveyor Toaster
Model CE-TW-0250
Item 11385
Instruction Manual



Revised - 08/18/2016



Toll Free: 1-800-465-0234
Fax: 905-607-0234
Email: service@omcan.com
www.omcan.com

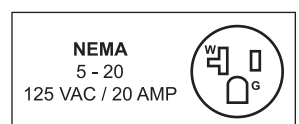

Table of Contents

Model CE-TW-0250

Section	Page
General Information -----	3 - 4
Safety and Warranty -----	4 - 5
Technical Specifications -----	5
Installation -----	6
Operation -----	6
Maintenance -----	6
Troubleshooting -----	6
Parts Breakdown -----	7
Electrical Schematics -----	8
Notes -----	9 - 10
Warranty Registration -----	11



General Information

Omcan Manufacturing and Distributing Company Inc., Food Machinery of America, Inc. dba Omcan and Omcan Inc. are not responsible for any harm or injury caused due to any person's improper or negligent use of this equipment. The product shall only be operated by someone over the age of 18, of sound mind, and not under the influence of any drugs or alcohol, who has been trained in the correct operation of this machine, and is wearing authorized, proper safety clothing. Any modification to the machine voids any warranty, and may cause harm to individuals using the machine or in the vicinity of the machine while in operation.

CHECK PACKAGE UPON ARRIVAL

Upon receipt of an Omcan shipment please inspect for external damage. If no damage is evident on the external packaging, open carton to ensure all ordered items are within the box, and there is no concealed damage to the machine. If the package has suffered rough handling, bumps or damage (visible or concealed), please note it on the bill of lading before accepting the delivery and contact Omcan within 24 hours, so we may initiate a claim with the carrier. A detailed report on the extent of the damage caused to the machine must be filled out within three days, from the delivery date shown in the shipping documents. Omcan has no recourse for damaged products that were shipped collect or third party.

Before operating any equipment, always read and familiarize yourself with all operation and safety instructions.

Omcan would like to thank you for purchasing this machine. It's of the utmost importance to save these instructions for future reference. Also save the original box and packaging for shipping the equipment if servicing or returning of the machine is required.

Omcan Fabrication et distribution Compañie Limité et Food Machinery d'Amérique, dba Omcan et Omcan Inc. ne sont pas responsables de tout dommage ou blessure causé du fait que toute personne ait utilisé cet équipement de façon irrégulière. Le produit ne doit être exploité que par quelqu'un de plus de 18 ans, saine d'esprit, et pas sous l'influence d'une drogue ou d'alcool, qui a été formé pour utiliser cette machine correctement, et est vêtu de vêtements de sécurité approprié. Toute modification de la machine annule toute garantie, et peut causer un préjudice à des personnes utilisant la machine ou des personnes à proximité de la machine pendant son fonctionnement.

VÉRIFIEZ LE COLIS DÈS RÉCEPTION

Dès réception d'une expédition d'Omcan veuillez inspecter pour dommages externes. Si aucun dommage n'est visible sur l'emballage externe, ouvrez le carton afin de s'assurer que tous les éléments commandés sont dans la boîte, et il n'y a aucun dommage dissimulé à la machine. Si le colis n'a subi aucune mauvaises manipulations, de bosses ou de dommages (visible ou cachée), notez-le sur le bond de livraison avant d'accepter la livraison et contactez Omcan dans les 24 heures qui suivent, pour que nous puissions engager une réclamation auprès du transporteur. Un rapport détaillé sur l'étendue des dommages causés à la machine doit être rempli dans un délai de trois jours, à compter de la date de livraison indiquée dans les documents d'expédition. Omcan n'a aucun droit de recours pour les produits endommagés qui ont été expédiés ou cueilli par un tiers transporteur.

General Information

Avant d'utiliser n'importe quel équipement, toujours lire et vous familiariser avec toutes les opérations et les consignes de sécurité.

Omcan voudrais vous remercier d'avoir choisi cette machine. Il est primordial de conserver ces instructions pour une référence ultérieure. Également conservez la boîte originale et l'emballage pour l'expédition de l'équipement si l'entretien ou le retour de la machine est nécessaire.

Omcan Empresa De Fabricacion Y Distribucion Inc. Y Maquinaria De Alimentos De America, Inc. dba Omcan y Omcan Inc. no son responsables de ningun daño o perjuicio causado por cualquier persona inadecuada o el uso descuidado de este equipo. El producto solo podra ser operado por una persona mayor de 18 años, en su sano juicio y no bajo alguna influencia de droga o alcohol, y que este ha sido entrenado en el correcto funcionamiento de esta máquina, y ésta usando ropa apropiada y autorizada. Cualquier modificación a la máquina anula la garantía y puede causar daños a las personas usando la máquina mientras esta en el funcionamiento.

REVISE EL PAQUETE A SU LLEGADA

Tras la recepcion de un envio Omcan favor inspeccionar daños externos. Si no hay daños evidentes en el empaque exterior, Habra el carton para asegurarse que todos los articulos solicitados estén dentro de la caja y no encuentre daños ocultos en la máquina. Si el paquete ha sufrido un manejo de poco cuidado, golpes o daños (visible o oculto) por favor anote en la factura antes de aceptar la entrega y contacte Omcan dentro de las 24 horas, de modo que podamos iniciar una reclamación con la compañía. Un informe detallado sobre los daños causados a la máquina debe ser llenado en el plazo de tres días, desde la fecha de entrega que se muestra en los documentos de envío. Omcan no tiene ningun recurso por productos dañados que se enviaron a recoger por terceros.

Antes de utilizar cualquier equipo, siempre lea y familiarizarse con todas las instrucciones de funcionamiento y seguridad.

Omcan le gustaría darle las gracias por la compra de esta máquina. Es de la mayor importancia para salvar estas instrucciones para futuras consultas. Además, guarda la caja original y el embalaje para el envío del equipo si servicio técnico o devolución de la máquina que se requiere.

Safety and Warranty

Do not touch the unit immediately after use as it will still be hot. If the power cord is damaged, it must be replaced by qualified technician. Contact the Omcan Service Center for any questions at 1-800-465-0234.

1 YEAR PART AND LABOUR BENCH WARRANTY

Within the warranty period, contact Omcan Inc. at 1-800-465-0234 to schedule a drop off to either an Omcan authorized service depot in the area, or to an Omcan Service warehouse to repair the



Safety and Warranty

equipment.

Unauthorized maintenance will void the warranty. Warranty covers electrical and part failures, not improper use.

Please see www.omcan.com/warranty.html for complete info.

WARNING:

The packaging components are classified as normal solid urban waste and can therefore be disposed of without difficulty.

In any case, for suitable recycling, we suggest disposing of the products separately (differentiated waste) according to the current norms.

DO NOT DISCARD ANY PACKAGING MATERIALS IN THE ENVIRONMENT!

Technical Specifications

Model	CE-TW-0250
Watts	1800 W
Opening Height	1.5" / 38mm
Amps	12.5 A
Slices	2
Capacity	300 slices/hr.
Electrical	120V/60/1
Weight	50 lbs. / 22.7 kgs.
Dimensions	22.8" x 14.5" x 15.3" / 579 x 368 x 389mm
Item Number	11385

This unit provides faster, more consistent toast than other units.

- Easy to use control panel takes the guess work out of temperature and speed control settings.
- Variable speed and top/bottom heat control for perfect color and texture of bread, bagels, English muffins and more.
- Energy efficient operation with power saver switch that reduces electricity consumption about 75%. The quartz heaters return to full power in seconds vs. minutes for metal-sheathed elements.
- Extended stainless steel conveyor belt for easy loading and large warming area for higher production.
- Safe load up area with full width coated front burn guard and cool to the touch exterior.
- Smart crumb tray keeps the bread crumbs from falling under the toaster.
- Heated holding area to keep toaster at the perfect temperature.
- Hi-limit switch prevents toaster from overheating protecting critical component parts.

Installation

Take out the Omcan Conveyor Toaster from the packaging and place the unit on a stable, level surface. When the unit is to be positioned in close proximity to a wall, partitions, kitchen furniture, decorative finished, other objects, etc., it is recommended that they be made of non-combustible material, if not, place a barrier between the unit and objects with a suitable non-combustible heat-insulating material. Follow all fire prevention regulations.

Operation

1. Turn the power to FULL POWER.
2. Try to set the conveyor speed on 4.
3. Allow warm-up time of 5 to 10 minutes.
4. Place a sample product on the conveyor belt to test the settings.
 - A. If toasting is too light, turn conveyor speed control counterclockwise to a slower speed.
 - B. If toasting is too dark, turn conveyor control clockwise to a faster speed.

Maintenance

When finished with the unit, turn the power switch off. It is recommended to not let the motor work continuously for a long time. The Conveyor Toaster should be cleaned using warm, soapy water after each day's operation. Do not immerse completely in water to clean. The appliance is not to be cleaned with a pressurized water jet.

Troubleshooting

If the Omcan Conveyor Toaster does not work, please check the following:

1. The power supply is correct and the toaster is switched on.
2. The positions of switch and thermostat are correct.

REFERENCE

Item Number	Model Number	Description	Manufacturer Model Number
11385	CE-TW-0250	Oven Conveyor 10" / 250mm Conveyor Width 2.5 HP / 1800 W 120V/60/1 CE cETLus	TS2002

Parts Breakdown

Model CE-TW-0250 11385

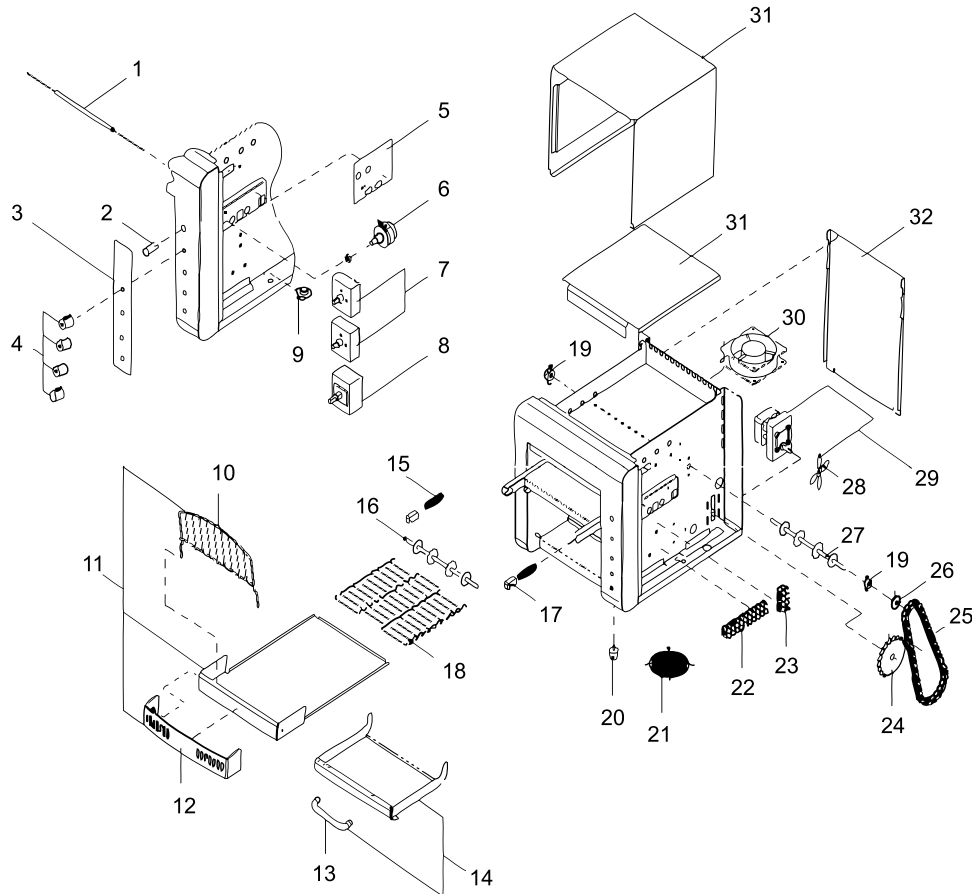

Model CE-TW-0250 11385

Item No.	Description	Position	Item No.	Description	Position	Item No.	Description	Position
19380	Element for TS2002	1	74070	Crumb Tray Guard for TS2002	12	74079	Terminal Block 4 for TS2002	23
74119	Neon Lamp for TS2002	2	74071	Collection Tray Handle for TS2002	13	74080	Drive Gear 17 for TS2002	24
74120	Control Label for TS2002	3	74072	Collection Tray Complete for TS2002	14	74081	Drive Chain for TS2002	25
19390	Control Knob for TS2002	4	74073	Front Bearing Spring for TS2002	15	74082	Drive Gear 11 & 13 for TS2002	26
74121	Element Retaining Plate for TS2002	5	74074	Driven Shaft for TS2002	16	74083	Drive Shaft for TS2002	27
19387	Speed Regulator Switch for TS2002	6	74075	Front Bearing for TS2002	17	74084	Fan Blades for TS2002	28
19286	Heat Regulator Switch for TS2002	7	24430	Conveyor Belt for TS2002	18	19385	Motor Complete for TS2002	29
19389	Power Control Switch for TS2002	8	74076	Shaft Bearing for TS2002	19	19382	Fan Motor for TS2002	30
19381	Reset Switch for TS2002	9	19383	Leg Conveyor for TS2002	20	74085	Top Airflow Plate for TS2002	31
17724	Feed Rack for TS2002	10	74077	Fan Cover for TS2002	21	74086	Back Panel for TS2002	32
21145	Crumb Tray Complete for TS2002	11	74078	Terminal Block 10 for TS2002	22	74087	Cover for TS2002	33

Electrical Schematics

Model CE-TW-0250 11385

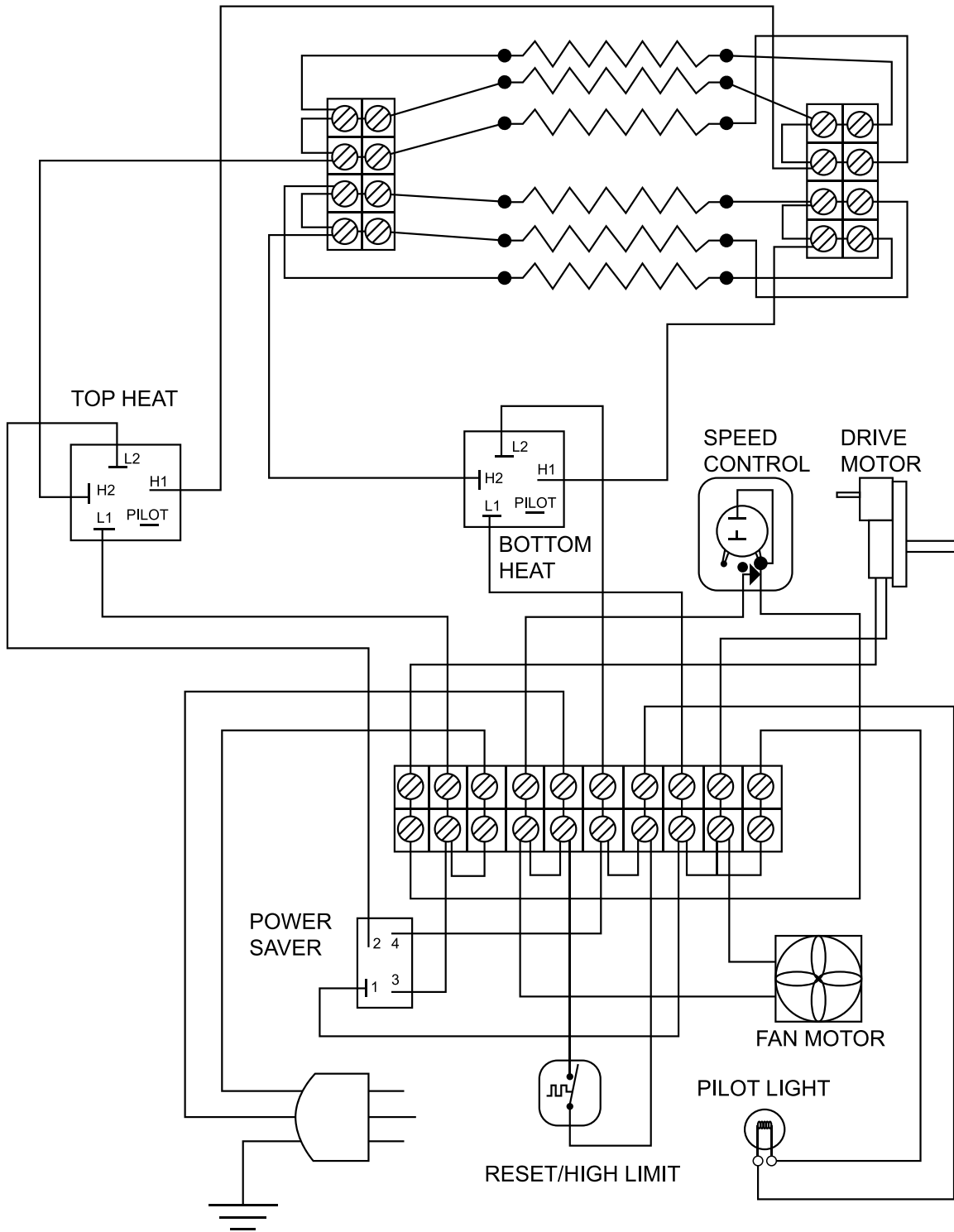



Warranty Registration

Thank you for purchasing an Omcan product. To register your warranty for this product, complete the information below, tear off the card at the perforation and then send to the address specified below. You can also register online by visiting:

Merci d'avoir acheté un produit Omcan. Pour enregistrer votre garantie pour ce produit, complétez les informations ci-dessous, détachez la carte au niveau de la perforation, puis l'envoyer à l'adresse spécifiée ci-dessous. Vous pouvez également vous inscrire en ligne en visitant:

Gracias por comprar un producto Omcan usted. Para registrar su garantía para este producto, complete la información a continuación, cortar la tarjeta en la perforación y luego enviarlo a la dirección indicada a continuación. También puede registrarse en línea en:

www.omcan.com/warrantyregistration.html

For mailing in Canada

Pour postale au Canada

Por correo en Canadá

OMCAN

PRODUCT WARRANTY REGISTRATION

3115 Pepper Mill Court,

Mississauga, Ontario

Canada, L5L 4X5

For mailing in the US

Pour diffusion aux États-Unis

Por correo en los EE.UU.

OMCAN

PRODUCT WARRANTY REGISTRATION

4450 Witmer Industrial Estates, Unit 4,

Niagara Falls, New York

USA, 14305

or email to: service@omcan.com



Purchaser's Information

Name: _____

Company Name: _____

Address: _____

Telephone: _____

City: _____ Province or State: _____ Postal or Zip: _____

Email Address: _____

Country: _____

Type of Company:

Restaurant Bakery Deli

Butcher Supermarket Caterer

Institution (specify): _____

Other (specify): _____

Dealer from which Purchased: _____

Dealer City: _____ Dealer Province or State: _____

Invoice: _____

Model Name: _____ Model Number: _____

Serial Number: _____

Machine Description: _____

Date of Purchase (MM/DD/YYYY): _____

Date of Installation (MM/DD/YYYY): _____

Would you like to extend the warranty? Yes No

Thank you for choosing Omcan | Merci d'avoir choisi Omcan | Gracias por elegir Omcan



Since 1951 Omcan has grown to become a leading distributor of equipment and supplies to the North American food service industry. Our success over these many years can be attributed to our commitment to strengthen and develop new and existing relationships with our valued customers and manufacturers. Today with partners in North America, Europe, Asia and South America, we continually work to improve and grow the company. We strive to offer customers exceptional value through our qualified local sales and service representatives who provide convenient access to over 3,500 globally sourced products.

Depuis 1951 Omcan a grandi pour devenir un des “leaders” de la distribution des équipements et matériel pour l’industrie des services alimentaires en Amérique du Nord. Notre succès au cours de ces nombreuses années peut être attribué à notre engagement à renforcer et à développer de nouvelles et existantes relations avec nos clients et les fabricants de valeur. Aujourd’hui avec des partenaires en Amérique du Nord, Europe, Asie et Amérique du Sud, nous travaillons continuellement à améliorer et développer l’entreprise. Nous nous efforçons d’offrir à nos clients une valeur exceptionnelle grâce à nos ventes locales qualifiées et des représentants de service qui offrent un accès facile à plus de 3500 produits provenant du monde entier.

Desde 1951 Omcan ha crecido hasta convertirse en un líder en la distribución de equipos y suministros de alimentos en América del Norte industria de servicios. Nuestro éxito en estos años se puede atribuir a nuestro compromiso de fortalecer y desarrollar nuevas relaciones existentes con nuestros valiosos clientes y fabricantes. Hoy con socios de América del Norte, Europa, Asia y América del Sur, que trabajan continuamente para mejorar y crecer la empresa. Nos esforzamos por ofrecer a nuestros clientes valor excepcional a través de nuestro local de ventas y representantes de los servicios que proporcionan un fácil acceso a más de 3,500 productos con origen a nivel mundial.

