



**Conveyor Oven**  
*Model CE-TW-0356*  
*Item 11387*  
**Instruction Manual**



*Revised - 11/30/2016*



Toll Free: 1-800-465-0234  
Fax: 905-607-0234  
Email: [service@omcan.com](mailto:service@omcan.com)  
[www.omcan.com](http://www.omcan.com)

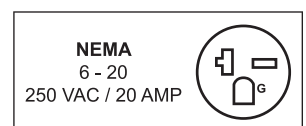

# ***Table of Contents***

Model CE-TW-0356

---

<b>Section</b>	<b>Page</b>
General Information -----	3 - 4
Safety and Warranty -----	4 - 5
Technical Specifications -----	6
Installation -----	6
Operation -----	7
Maintenance -----	7 - 11
Parts Breakdown -----	11 - 17
Electrical Schematics -----	18
Warranty Registration -----	19



# General Information

---

Omcan Manufacturing and Distributing Company Inc., Food Machinery of America, Inc. dba Omcan and Omcan Inc. are not responsible for any harm or injury caused due to any person's improper or negligent use of this equipment. The product shall only be operated by someone over the age of 18, of sound mind, and not under the influence of any drugs or alcohol, who has been trained in the correct operation of this machine, and is wearing authorized, proper safety clothing. Any modification to the machine voids any warranty, and may cause harm to individuals using the machine or in the vicinity of the machine while in operation.

## CHECK PACKAGE UPON ARRIVAL

Upon receipt of an Omcan shipment please inspect for external damage. If no damage is evident on the external packaging, open carton to ensure all ordered items are within the box, and there is no concealed damage to the machine. If the package has suffered rough handling, bumps or damage (visible or concealed), please note it on the bill of lading before accepting the delivery and contact Omcan within 24 hours, so we may initiate a claim with the carrier. A detailed report on the extent of the damage caused to the machine must be filled out within three days, from the delivery date shown in the shipping documents. Omcan has no recourse for damaged products that were shipped collect or third party.

**Before operating any equipment, always read and familiarize yourself with all operation and safety instructions.**

Omcan would like to thank you for purchasing this machine. It's of the utmost importance to save these instructions for future reference. Also save the original box and packaging for shipping the equipment if servicing or returning of the machine is required.

---

Omcan Fabrication et distribution Compañie Limité et Food Machinery d'Amérique, dba Omcan et Omcan Inc. ne sont pas responsables de tout dommage ou blessure causé du fait que toute personne ait utilisé cet équipement de façon irrégulière. Le produit ne doit être exploité que par quelqu'un de plus de 18 ans, saine d'esprit, et pas sous l'influence d'une drogue ou d'alcool, qui a été formé pour utiliser cette machine correctement, et est vêtu de vêtements de sécurité approprié. Toute modification de la machine annule toute garantie, et peut causer un préjudice à des personnes utilisant la machine ou des personnes à proximité de la machine pendant son fonctionnement.

## VÉRIFIEZ LE COLIS DÈS RÉCEPTION

Dès réception d'une expédition d'Omcan veuillez inspecter pour dommages externes. Si aucun dommage n'est visible sur l'emballage externe, ouvrez le carton afin de s'assurer que tous les éléments commandés sont dans la boîte, et il n'y a aucun dommage dissimulé à la machine. Si le colis n'a subi aucune mauvaises manipulations, de bosses ou de dommages (visible ou cachée), notez-le sur le bond de livraison avant d'accepter la livraison et contactez Omcan dans les 24 heures qui suivent, pour que nous puissions engager une réclamation auprès du transporteur. Un rapport détaillé sur l'étendue des dommages causés à la machine doit être rempli dans un délai de trois jours, à compter de la date de livraison indiquée dans les documents d'expédition. Omcan n'a aucun droit de recours pour les produits endommagés qui ont été expédiés ou cueilli par un tiers transporteur.

# General Information

---

Avant d'utiliser n'importe quel équipement, toujours lire et vous familiariser avec toutes les opérations et les consignes de sécurité.

Omcán voudrais vous remercier d'avoir choisi cette machine. Il est primordial de conserver ces instructions pour une référence ultérieure. Également conservez la boîte originale et l'emballage pour l'expédition de l'équipement si l'entretien ou le retour de la machine est nécessaire.

---

Omcán Empresa De Fabricación Y Distribución Inc. Y Maquinaria De Alimentos De América, Inc. dba Omcán y Omcán Inc. no son responsables de ningún daño o perjuicio causado por cualquier persona inadecuada o el uso descuidado de este equipo. El producto solo podrá ser operado por una persona mayor de 18 años, en su sano juicio y no bajo alguna influencia de droga o alcohol, y que este ha sido entrenado en el correcto funcionamiento de esta máquina, y ésta usando ropa apropiada y autorizada. Cualquier modificación a la máquina anula la garantía y puede causar daños a las personas usando la máquina mientras esta en el funcionamiento.

## REVISE EL PAQUETE A SU LLEGADA

Tras la recepción de un envío Omcán favor inspeccionar daños externos. Si no hay daños evidentes en el empaque exterior, abra el cartón para asegurarse que todos los artículos solicitados estén dentro de la caja y no encuentre daños ocultos en la máquina. Si el paquete ha sufrido un manejo de poco cuidado, golpes o daños (visible o oculto) por favor anote en la factura antes de aceptar la entrega y contacte Omcán dentro de las 24 horas, de modo que podamos iniciar una reclamación con la compañía. Un informe detallado sobre los daños causados a la máquina debe ser llenado en el plazo de tres días, desde la fecha de entrega que se muestra en los documentos de envío. Omcán no tiene ningún recurso por productos dañados que se enviaron a recoger por terceros.

Antes de utilizar cualquier equipo, siempre lea y familiarizarse con todas las instrucciones de funcionamiento y seguridad.

Omcán le gustaría darle las gracias por la compra de esta máquina. Es de la mayor importancia para salvar estas instrucciones para futuras consultas. Además, guarda la caja original y el embalaje para el envío del equipo si servicio técnico o devolución de la máquina que se requiere.

# Safety and Warranty

---

- Disconnect power to the unit from receptacle at the end of each day.
- Do not leave the unit in operation without an attendant.
- Do not leave the unit at high temperature when not in use or during idle periods. This will cause food particles and grease film to carbonize and burn.
- Turning the temperature setting down will save energy. It will take only a few minutes for the unit to regain operating temperature.
- Never immerse the unit in water as it will cause damage to the unit and the warranty will be voided.

# *Safety and Warranty*

---

- DO NOT CLEAN WITH WATER JETS.
- Do not touch to the handle of drawer with “HOT SURFACE” when the unit is operating.
- Variable speed and top/bottom heat control for perfect color and texture of bread, bagels, English muffins and more.
- Extended stainless steel conveyor belt for easy loading and large warming area for higher production.
- Safe load up area with full width coated front burn guard and cool to the touch exterior.
- Smart crumb tray keeps the bread crumbs from falling under the toaster.
- Heated holding area to keep toaster at the perfect temperature.
- Hi-limit switch prevents toaster from overheating protecting critical component parts.
- Preventive maintenance for this unit consists of the recommended cleaning procedures later in the manual. To keep your oven in its top operating condition. These steps should be performed daily, weekly or as required.

**Turn unit off, disconnect unit from power supply or turn power off at wall breaker, remove plug from outlet.**

## **1 YEAR PARTS AND LABOUR BENCH WARRANTY**

**Within the warranty period, contact Omcan Inc. at 1-800-465-0234 to schedule a drop off to either an Omcan authorized service depot in the area, or to an Omcan Service warehouse to repair the equipment.**

**Unauthorized maintenance will void the warranty. Warranty covers electrical and part failures, not improper use.**

### **WARNING:**

The packaging components are classified as normal solid urban waste and can therefore be disposed of without difficulty.

**In any case, for suitable recycling, we suggest disposing of the products separately (differentiated waste) according to the current norms.**

**DO NOT DISCARD ANY PACKAGING MATERIALS IN THE ENVIRONMENT!**

# Technical Specifications

<b>Model</b>	<b>CE-TW-0356</b>
<b>Amps</b>	15 Amps
<b>Watts</b>	3600 W
<b>Opening Height</b>	3.25" / 88mm
<b>Capacity</b>	Twelve - 14" / 356mm pizza/h
<b>Electrical</b>	240V / 60Hz
<b>Maximum Temperature</b>	250° - 260°C / 482°F - 500°F
<b>Weight</b>	53 lbs. / 24 kg.
<b>Dimension (DWH)</b>	41" x 18.5" x 15.5" / 1041mm x 470mm x 394mm
<b>Item Number</b>	11387

## TEMPERATURE SETTINGS AND TIMES

<b>Setting</b>	<b>Temperature (Top and Bottom Heat)</b>	<b>Time (Minutes - Seconds)</b>
Dial 1	70-90°C / 158-194°F	1 Minute - 20 Seconds
Dial 2	90-110°C / 194-230°F	1 Minute - 45 Seconds
Dial 3	130-140°C / 266-284°F	3 Minutes - 30 Seconds
Dial 4	140-155°C / 284-311°F	4 Minutes - 20 Seconds
Dial 5	155-180°C / 311-356°F	5 Minutes - 5 Seconds
Dial 6	185-205°C / 365-401°F	5 Minutes - 45 Seconds
Dial 7	205-220°C / 401-428°F	6 Minutes - 35 Seconds
Dial 8	240-260°C / 464-500°F	7 Minutes - 45 Seconds
Dial 9	250-260°C / 482-500°F	8 Minutes - 50 Seconds
Dial 10	250-260°C / 482-500°F	10 Minutes - 5 Seconds

## Installation

- Place on a level and stable surface.
- Keep the unit away from flammable objects.
- Ensure that the power cord and the socket are not damaged prior to use, and socket is the correct electrical rating for this toaster.



# Operation

1. Turn the power to FULL power.
2. Set the conveyor speed on 4.
3. Allow warm-up time of 5 to 10 minutes.
4. Place a sample product on the conveyor belt to test the setting.
  - A. If toasting is too light, turn conveyor speed control clockwise to a slow speed.
  - B. If toasting is too dark, turn conveyor control clockwise to a faster speed.

## RECOMMENDED COOKING TIMES

Product	Top Heat	Bottom Heat	Belt Speed
Pizza 12" Blanched	300°F / 148.9°C	400°F / 204.4°C	6 minutes
Meat and Cheese Sandwich	450°F / 232.2°C	300°F / 148.9°C	4 minutes
Meatball	500°F / 260°C	350°F / 176.7°C	2 minutes
Bagel (open)	500°F / 260°C	400°F / 204.4°C	2 minutes
1 oz. cookies	200°F / 93.3°C	250°F / 121.1°C	10 minutes
Garlic Bread Lightly Seasoned	500°F / 260°C	500°F / 260°C	2 minutes
Fish Sizzle Platter	400°F / 204.4°C	500°F / 260°C	6 minutes

# Maintenance

## CLEANING

### DAILY

1. Turn main power switch to the OFF position, Disconnect unit from power source and allow unit to cool.
2. Using a mild detergent, wipe exterior surfaces, clean with a damp cloth.
  - A. For lightly soiled build-up, clean with a damp cloth.
  - B. For heavily soiled build-up, use a soft damp cloth and mild detergent. **DO NOT USE CORROSIVE CLEANERS.**
3. Remove the load and unload tray by lifting it out of position. Clean using mild detergent and warm water.
4. Remove each crumb tray by sliding each of them out from under the conveyor belt. Clean crumb tray by wiping with a damp cloth and mild detergent. **DO NOT** use corrosive cleaners. Place trays in place prior to putting unit back into operating.
5. Reconnect power.

**Note: When placing the tray back into position, be sure that the message “CAUTION HOT SURFACE” is the right side up.**

# Maintenance

## WEEKLY

### CLEANING THE CONVEYOR BELT

1. Turn power switch to the OFF position. Disconnection unit from power source and allow to cool.
2. Perform daily cleaning procedures.
3. Using a damp cloth, wipe the fan guard located on the box cover under the unit. Reconnect power or turn power back on.
4. Switch the ON/OFF switch to the ON position, and turn conveyor to its fastest setting (Make sure the heater is off).
5. With the conveyor turned on and the crumb tray in place, take a wire grill brush or dry abrasive pad, clean the exposed surface of conveyor belt by passing the brush or pad, back and forth across the surface of the conveyor belt as the belt moves past (Figure 1). Continue until the entire belt is clean. Make sure the crumb tray is installed, this will minimize the amount of particles that fall into the oven.
6. When the conveyor belt is clean, take a damp cloth and wipe the conveyor, removing any loose particles on the belt surface.
7. Remove the crumb tray by sliding it out from beneath the conveyor belt. Clean the crumb tray by wiping with a damp cloth and mild detergent.

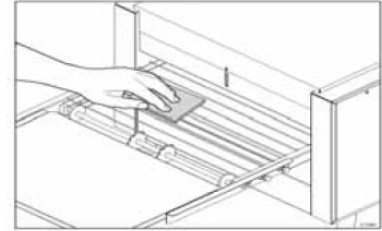

Figure 1

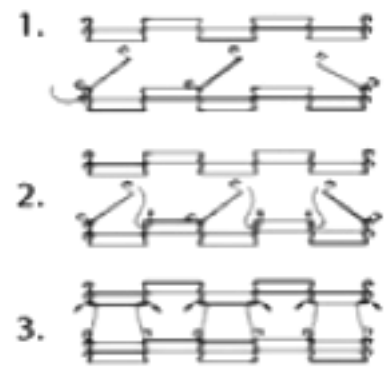

Fig 2. Master Links  
Removal & Installation

- Do not use corrosive cleaners.
- Do not run conveyor oven without crumb trays installed.
- Overheating to electrical components and premature failure can occur.
- Do not immerse or let the unit stand in water.
- Do not hose down the unit or the table/counter if the unit is on the table/counter.
- Keep away from running water.

## MONTHLY

### REMOVAL AND CLEANING OF CONVEYOR BELT

1. Turn main power switch to the OFF position. Disconnect unit from its power source and allow to cool.
2. Perform daily and weekly cleaning procedures. Follow the step 1 in Fig 2, to remove all of the master links. To remove, unhook each end of one link and bring the two ends together, and un-thread. Once detached, re-hook onto itself so not to get damaged.
3. Now that the links have been unhooked, the conveyor can now be carefully removed from the oven. Standing at one end of the oven. Starting with the end on the bottom, roll the conveyor belt until it has been totally removed. Take careful notice being sure not to damage the heater tubes, and working it over the drive sprockets, (see Figure 3).
4. Clean conveyor belt in deep sink, caustic cleaners may be used. For a heavy soiled conveyor belt, soak over night in hot soapy water.

**NOTE: Do not attempt to clean the heater tubes.**

# Maintenance

5. Take this opportunity to clean and remove any loose materials inside the unit. Using a mild cleaner and damp cloth, carefully wipe the inside surfaces being sure NOT to clean the heater tubes. **DAMAGE CAN OCCUR TO THE HEATER TUBES FROM IMPROPER CLEANING. DO NOT SPRAY CLEANING SOLUTIONS INTO OVEN CAVITY.**
6. Reinstall conveyor belt by first laying the belt along the bottom of the oven cavity making sure the hooks on the sides are facing the inside and ends of the hooks will be pointing away from the direction of the belt so not to catch on any internal components once put back into operating. Also, being sure to properly align the belt over the conveyor drive sprockets shown in Fig 3.

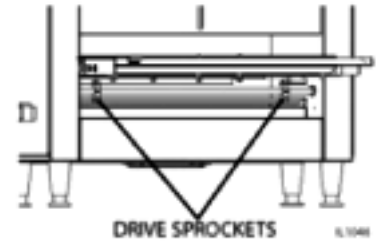

Fig 3. Conveyor Drive Sprockets

**NOTE: The direction of the belt.**

7. Next, pull one end of the conveyor belt over the top of the sprockets, (being sure to line the links up properly with the sprockets) bring the two ends together.
8. Reinstall the previously removed master links as shown in step 2 & 3 in Fig.2. Unhook the last link of the conveyor, farthest away from you, and re-thread through the other end, and reconnect back onto itself.
9. Examine the oven to assure proper installation, once satisfied, install crumb trays if you have not done so. **DO NOT OPERATE UNIT WITHOUT CRUMB TRAYS INSTALLED.**
10. Reconnect oven to power supply and check for proper operation.

## REPLACING HEATER TUBES

1. DISCONNECT POWER SOURCE.
2. Remove the top cover panel. By removing the truss head screws. Pull the top cover panel out slightly.
3. Remove each heater tube wires which are requiring replacement from its terminal block connection. One tube at a time.
4. Remove heater tube retainer by removing retainer screws with washer.
5. Gently, pull defective heater tube out of unit.
6. Gently, put new heater tube into unit.
7. Replace heater tube retainers.
8. Reconnect the heater tube wires to the terminal block.
9. Install top cover panel.
10. Connect unit to power source and test unit for proper operation.

## REPLACING FAN MOTOR

1. DISCONNECT POWER SOURCE.
2. After unit has cooled, remove the crumb tray, and turn unit over so this bottom is facing upward. Never place unit on its side.
3. Unplug power supply cord from fan motor.
4. Remove screws which hold fan motor and grill to the control box cover and remove fan.
5. Once removed, clean fan grill and control box cover using warm soapy water.
6. Put replacement motor and grill in place and secure to control box cover with screws previously removed.
7. Reconnect power supply cord to fan motor.

# Maintenance

---

8. Replace back panel and enclosure.
9. Connect unit to power source, reinstall the crumb tray and test unit for proper operation.

## REPLACING BELT DRIVE MOTOR

1. DISCONNECT POWER SOURCE.
2. After unit has cooled, remove the crumb tray and turn unit over so the bottom is facing upward. Never place unit on its side.
3. Remove the control box cover which contains the fan motor.
4. Remove the cover that will expose the drive chain and sprockets.
5. Remove the sprockets from motor shaft, using an Allen wrench and loosening the set-screw.
6. Remove the wire from terminal block connecting the drive motor to the internal wiring.
7. Remove screws holding motor in place and remove motor from unit.
8. Put new motor in place and attach loosely with mounting screws.
9. Replace sprocket on motor shaft.

**NOTE: The two sprockets must line up flush with each other, so the chain does not twist any during operating. Also the hub gets installed closest to the motor.**

10. Slide motor unit the drive chain has about 1/4" slack when lightly pushed at the center of its top open run. (See chain tensioning illustration.)
11. Tighten screw to secure motor.
12. Rewire leads.
13. At this time you may plug unit in and test for proper operation prior to reinstalling panel and turning unit back over onto its feet.
14. If unit is working correctly, turn unit off and unplug unit completed.
15. Reinstall side panels and control box cover. Place unit back into its upright position. Reinstall the crumb tray.
16. Connect unit to power source and test unit for proper operation.

## CLEANING AIR INTAKE ONCE A WEEK

1. DISCONNECT POWER SOURCE.
2. Place unit upside down. NOTE: you may damage the heater tubes by placing unit on its side.
3. Use a vacuum cleaner and or a damp cloth to clean the air intake. The procedure should be done at least once a week.

## LUBRICATE THE CHAIN & SPROCKETS EVERY MONTHS

1. DISCONNECT POWER SOURCE.
2. Remove the panel which exposes chain drive.
3. Using an extreme pressure, synthetic chain lubricant with a temperature range up to 400°F. Apply liberally onto chain and sprockets.
4. Replace panel, reconnect power source and test unit.

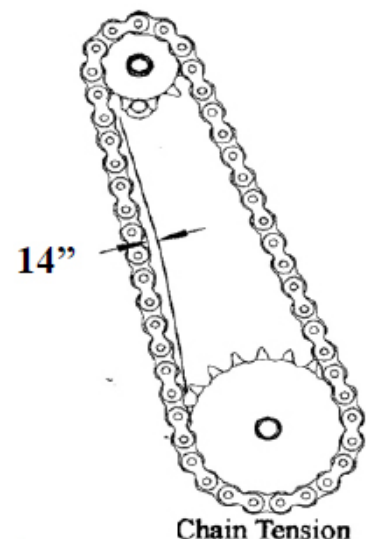

# Maintenance

## REFERENCE

Item Number	Model Number	Description	Manufacturer Model Number
11387	CE-TW-0356	Oven Conveyor 14" / 356mm 4.75 HP / 3600 W 240V/60/1 cETL	TS7000

## Parts Breakdown

**Model CE-TW-0356** 11387

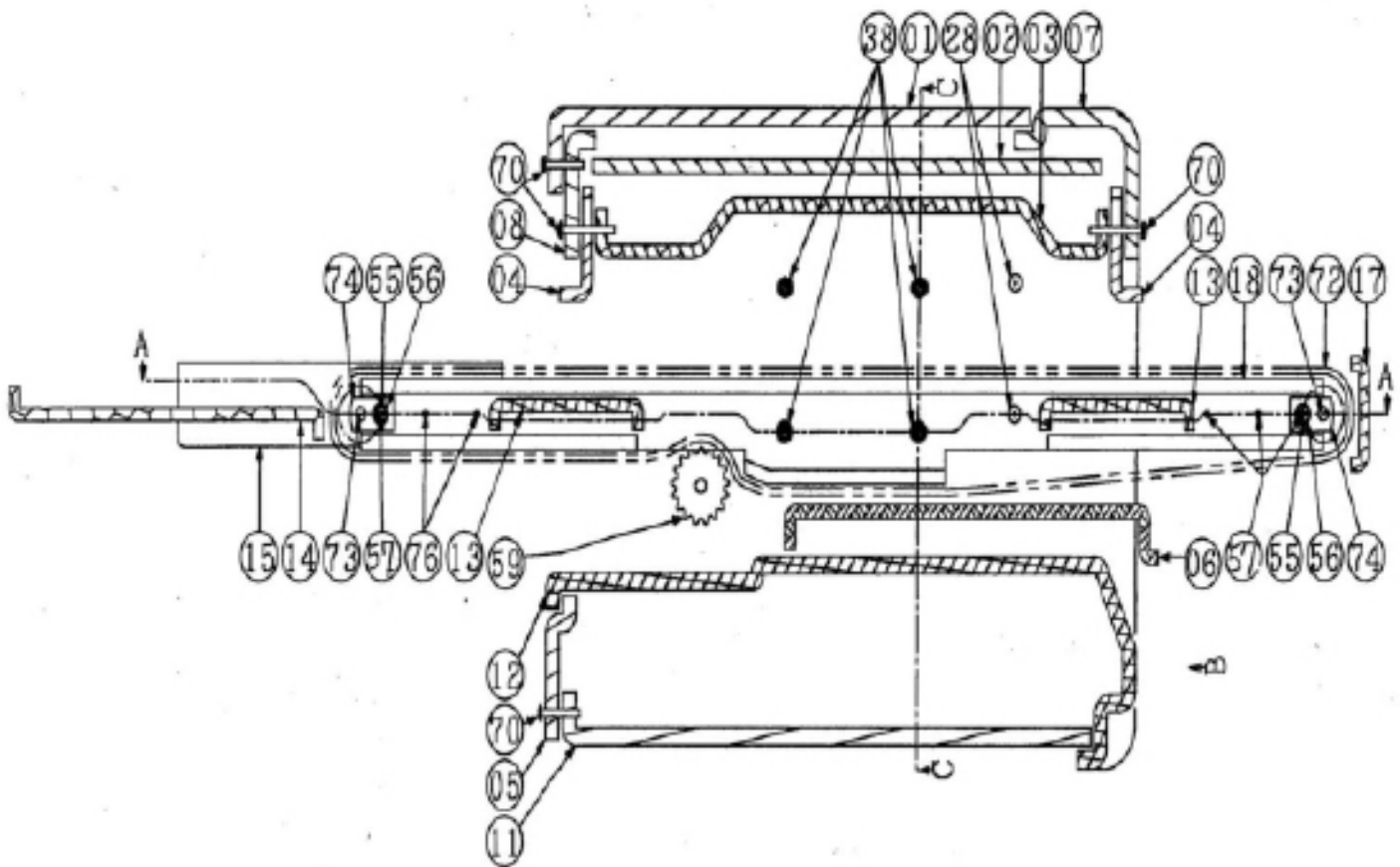

# Parts Breakdown

Model CE-TW-0356 11387

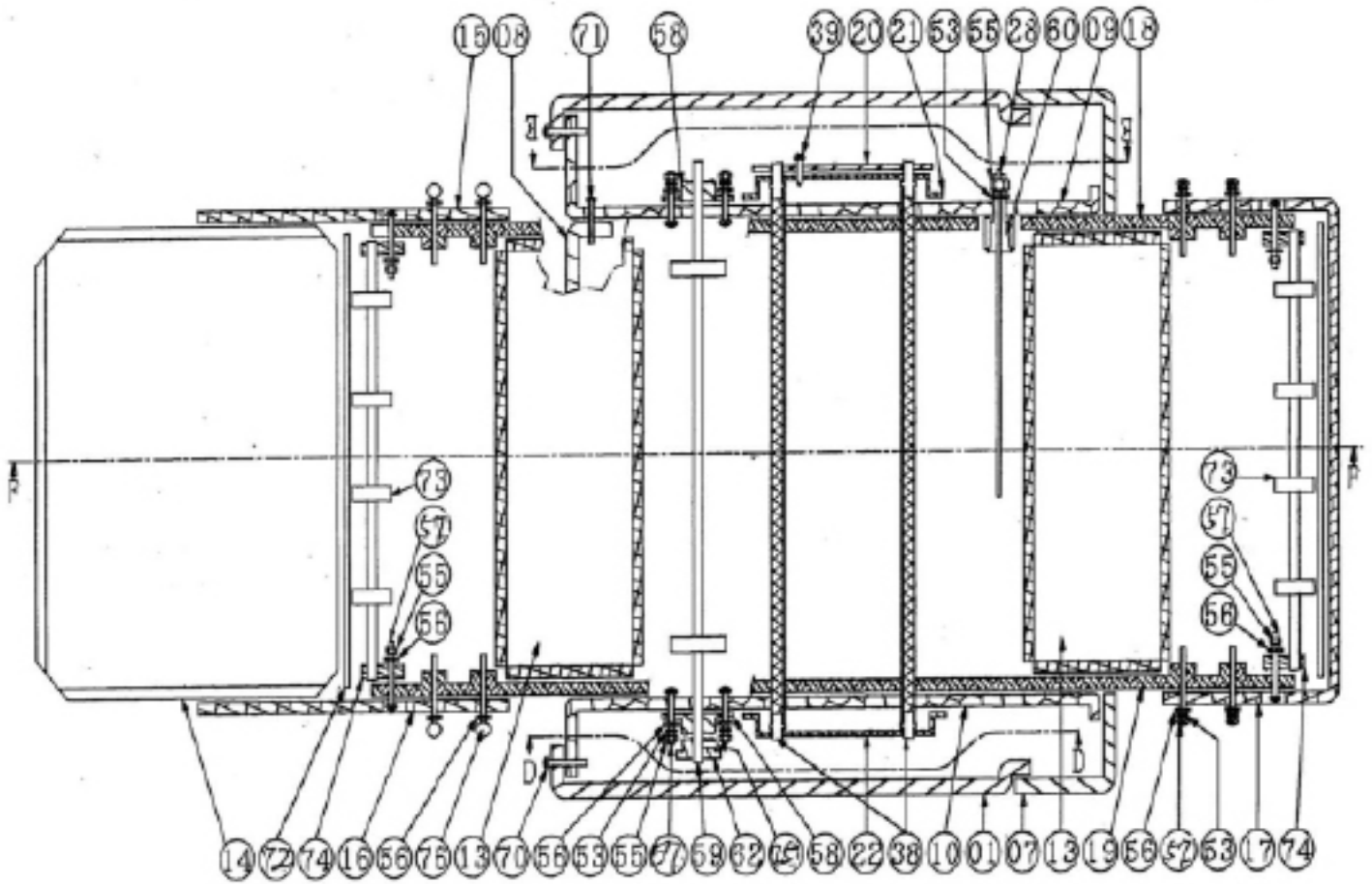

# Parts Breakdown

Model CE-TW-0356 11387

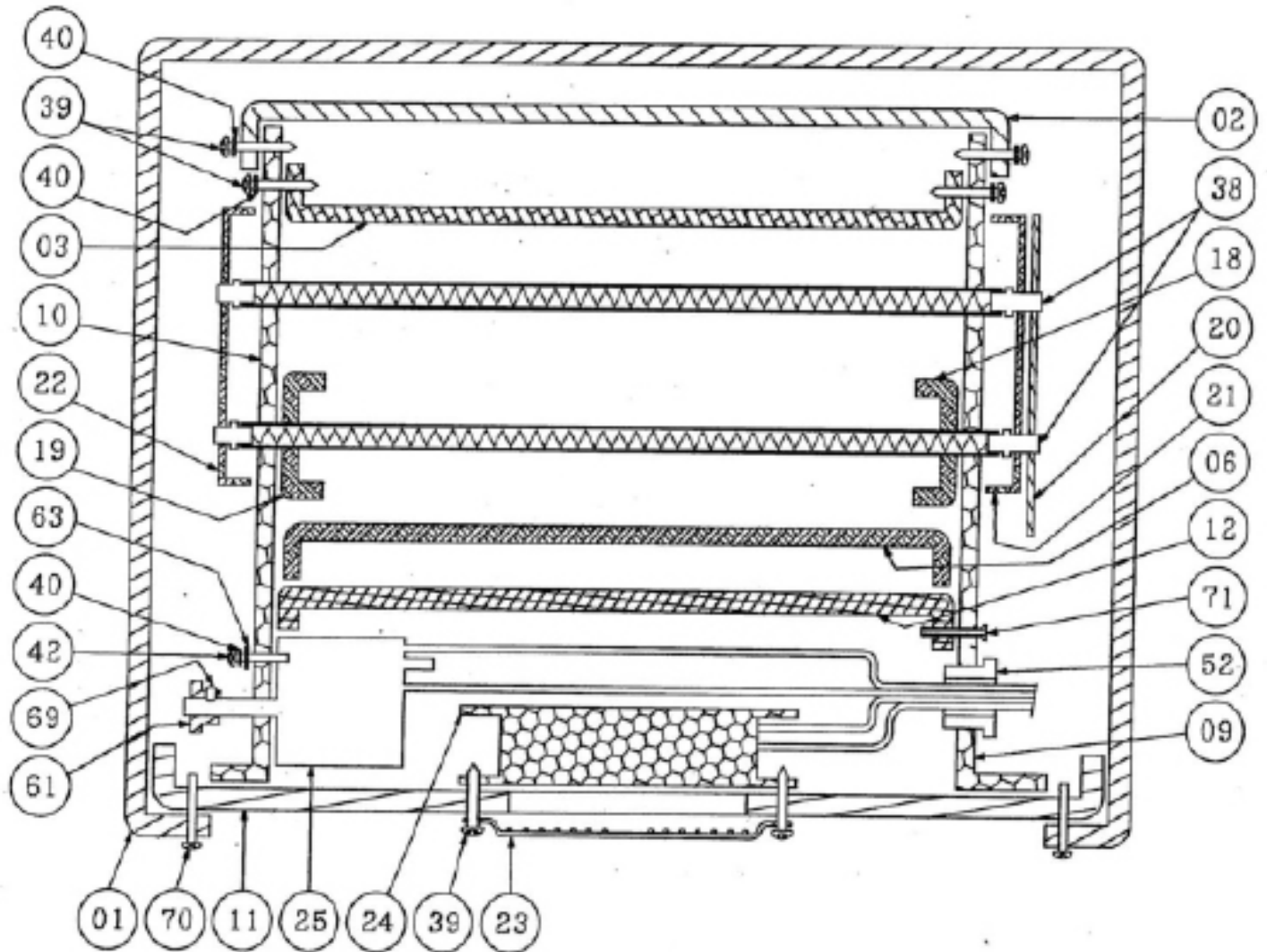

# Parts Breakdown

Model CE-TW-0356 11387

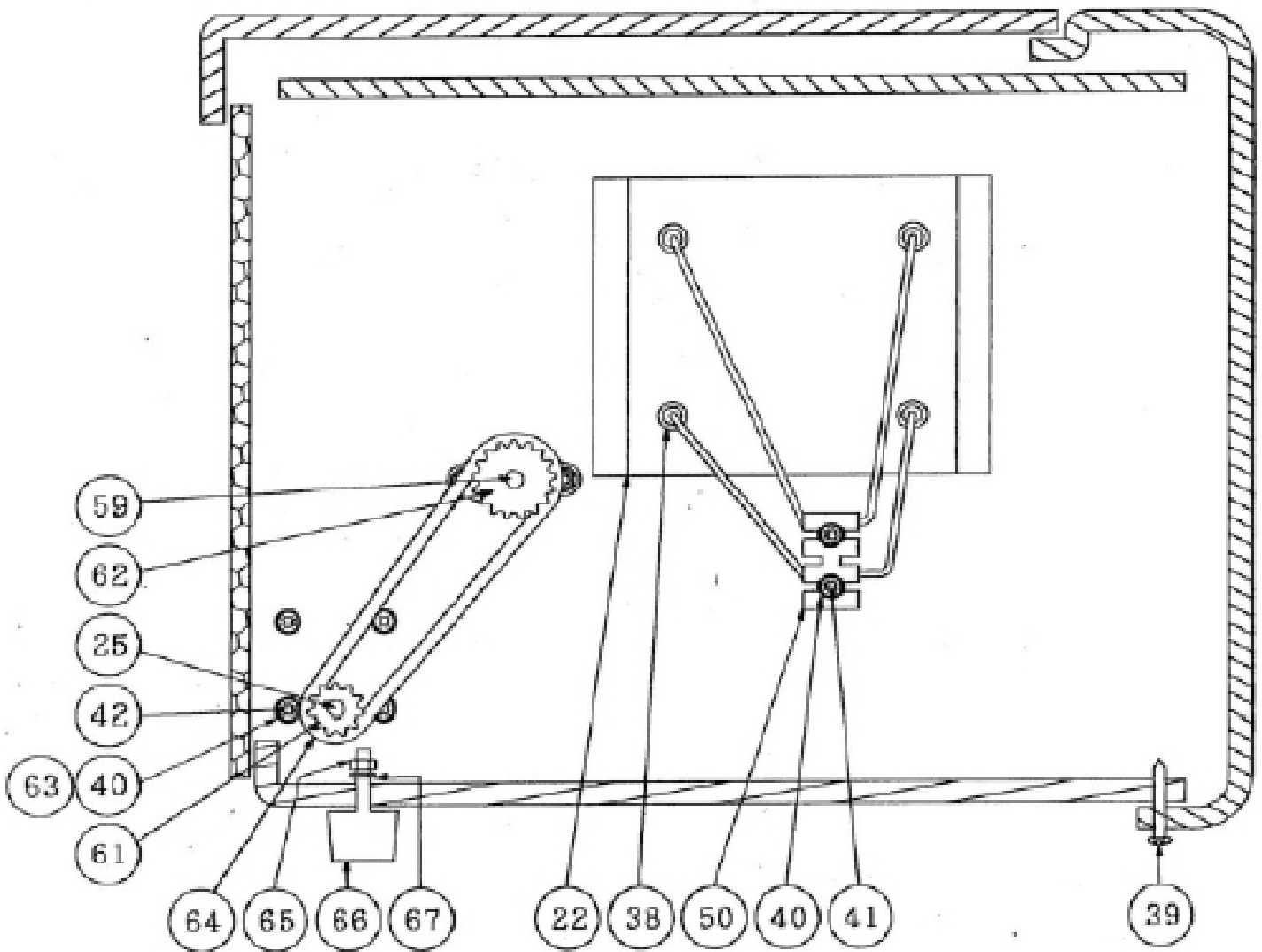

# Parts Breakdown

Model CE-TW-0356 11387

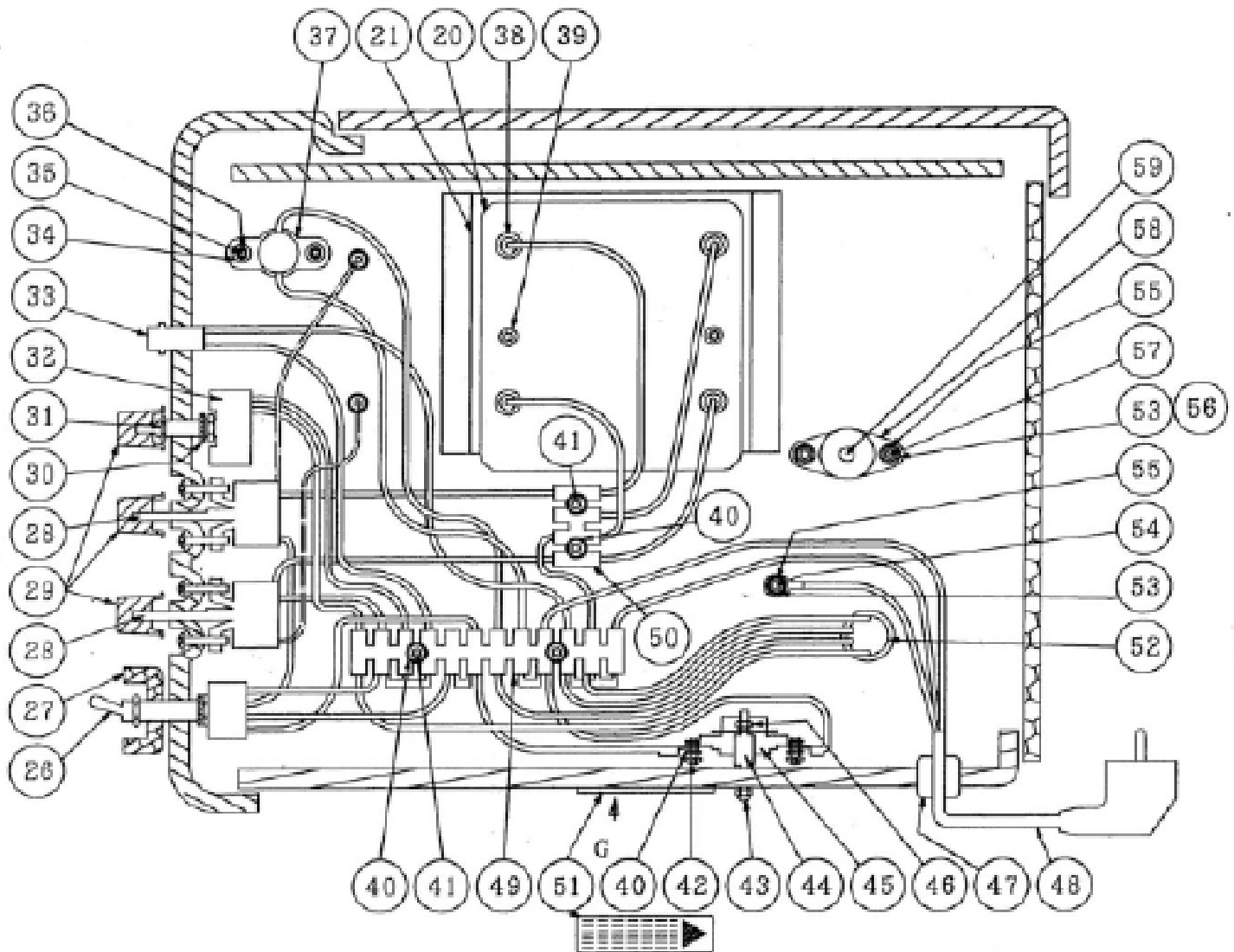

# Parts Breakdown

---

**Model CE-TW-0356** 11387

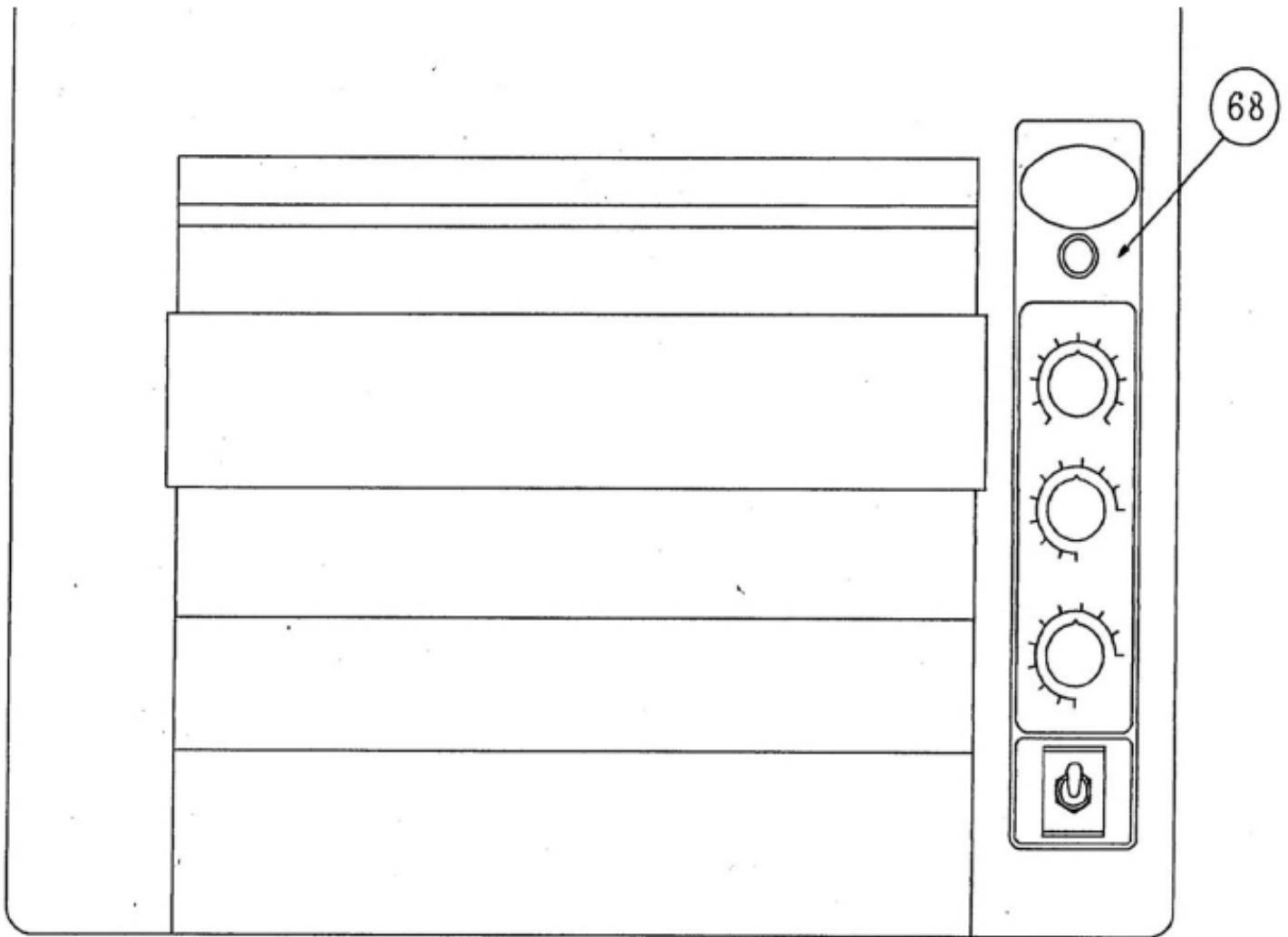

# Parts Breakdown

## Model CE-TW-0356 11387

Item No.	Description	Position	Item No.	Description	Position	Item No.	Description	Position
19023	Stainless Steel Cover for TS7000	01	19035	Conveyor Frame for TS7000	13	19047	Indicate Light for TS7000	33
19024	Fan Terminal for TS7000	02	27537	Stainless Steel Complete Tray for TS7000	14-16	19048	T.O.D.36 F65 for TS7000	37
19025	Insulation Plate for TS7000	03	19037	Protection for Conveyor for TS7000	17-19	19049	Element 240V 3600W for TS7000	38
19026	Plate Front for TS7000	04	19038	Protection for Tube Element for TS7000	20-22	19050	CR-1 Thermostat (Top - Speed Control) for TS7000	45
19027	Cover Rear for TS7000	05	19039	Fan with Protection for TS7000	23-24	19051	Terminal PA-12 (12P) for TS7000	49
19028	Drawer for TS7000	06	19040	Drive Motor Complete for TS7000	25	40560	Terminal for TS7000	50
19029	Front Plate for TS7000	07	19041	4P On/Off Switch for TS7000	26	19393	Drive Shaft for TS7000	59
19030	Rear Plate for TS7000	08	19042	Switch Protection for TS7000	27	19052	Gear 11T for TS7000	61
19031	Left Plate for TS7000	09	19043	Ego Switch 250C (for Controlled Upper Heater) for TS7000	28-1	19053	Gear 17T for TS7000	62
19032	Right Plate for TS7000	10	19044	Ego Switch 320C (for Controlled Bottom Heater) for TS7000	28-2	40561	Chain (#25x56 Mesh) for TS7000	64
19033	Base Plate for TS7000	11	19045	Knob for TS7000	29	19054	Stainless Steel Conveyor Belt (Width 35.5cm) for TS7000	72
19034	Insulation Plate Middle for TS7000	12	19046	Speed Regular Controller 230V 1000 Omega for TS7000	32			

# Electrical Schematics

Model CE-TW-0356 11387

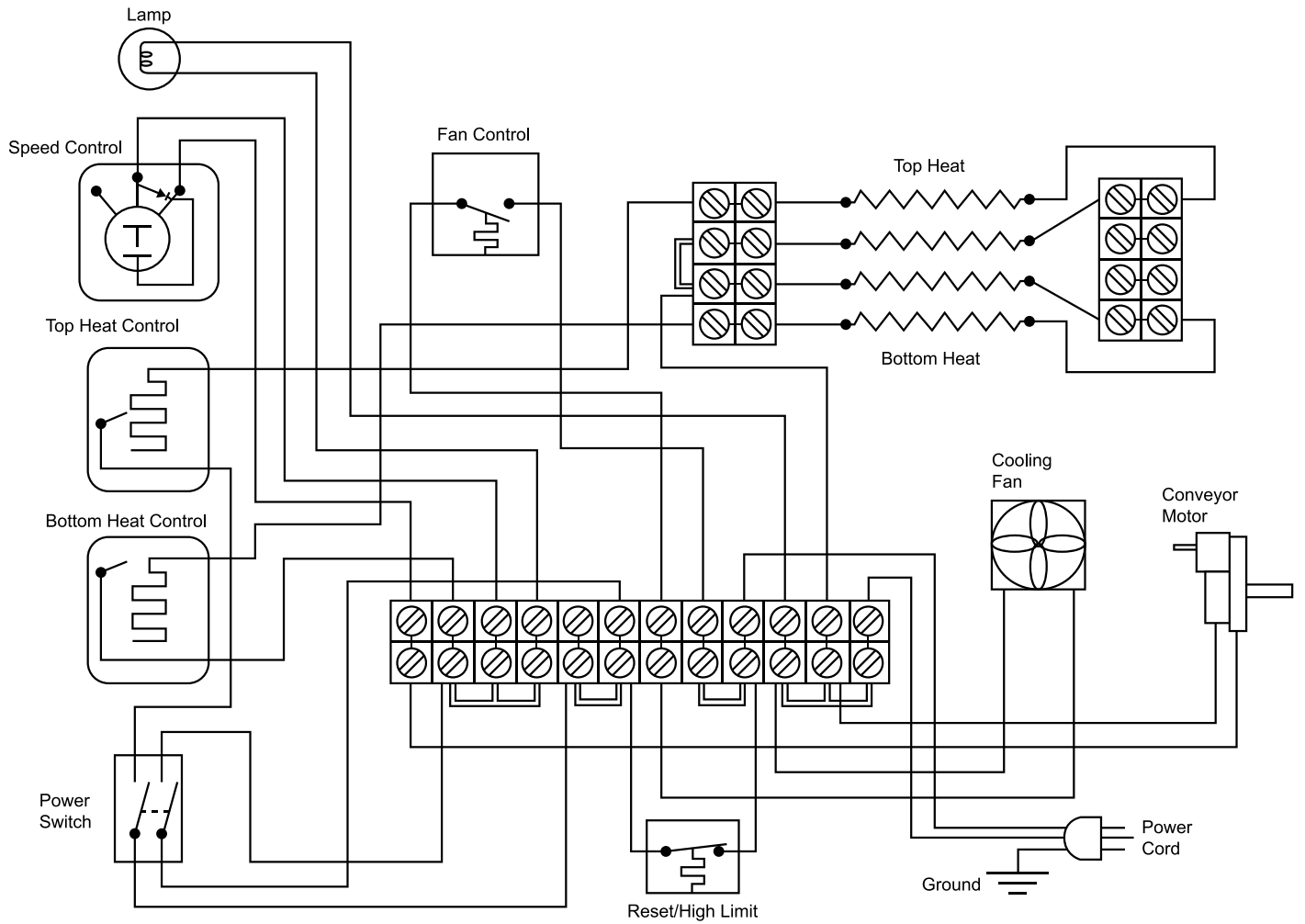



# Warranty Registration

Thank you for purchasing an Omcan product. To register your warranty for this product, complete the information below, tear off the card at the perforation and then send to the address specified below. You can also register online by visiting:

Merci d'avoir acheté un produit Omcan. Pour enregistrer votre garantie pour ce produit, complétez les informations ci-dessous, détachez la carte au niveau de la perforation, puis l'envoyer à l'adresse spécifiée ci-dessous. Vous pouvez également vous inscrire en ligne en visitant:

Gracias por comprar un producto Omcan usted. Para registrar su garantía para este producto, complete la información a continuación, cortar la tarjeta en la perforación y luego enviarlo a la dirección indicada a continuación. También puede registrarse en línea en:

**[www.omcan.com/warrantyregistration.html](http://www.omcan.com/warrantyregistration.html)**

**For mailing in Canada**

**Pour postale au Canada**

**Por correo en Canadá**

**For mailing in the US**

**Pour diffusion aux États-Unis**

**Por correo en los EE.UU.**

**OMCAN**

PRODUCT WARRANTY REGISTRATION

3115 Pepper Mill Court,

Mississauga, Ontario

Canada, L5L 4X5

**OMCAN**

PRODUCT WARRANTY REGISTRATION

4450 Witmer Industrial Estates, Unit 4,

Niagara Falls, New York

USA, 14305

**or email to: [service@omcan.com](mailto:service@omcan.com)**



**Purchaser's Information**

Name: \_\_\_\_\_

Company Name: \_\_\_\_\_

Address: \_\_\_\_\_

Telephone: \_\_\_\_\_

City: \_\_\_\_\_ Province or State: \_\_\_\_\_ Postal or Zip: \_\_\_\_\_

Email Address: \_\_\_\_\_

Country: \_\_\_\_\_

Type of Company:

Restaurant  Bakery  Deli

Butcher  Supermarket  Caterer

Institution (*specify*): \_\_\_\_\_

Other (*specify*): \_\_\_\_\_

Dealer from which Purchased: \_\_\_\_\_

Dealer City: \_\_\_\_\_ Dealer Province or State: \_\_\_\_\_

Invoice: \_\_\_\_\_

Model Name: \_\_\_\_\_ Model Number: \_\_\_\_\_

Serial Number: \_\_\_\_\_

Machine Description: \_\_\_\_\_

Date of Purchase (MM/DD/YYYY): \_\_\_\_\_

Date of Installation (MM/DD/YYYY): \_\_\_\_\_

Would you like to extend the warranty?  Yes  No

**Thank you for choosing Omcan | Merci d'avoir choisi Omcan | Gracias por elegir Omcan**



Since 1951 Omcan has grown to become a leading distributor of equipment and supplies to the North American food service industry. Our success over these many years can be attributed to our commitment to strengthen and develop new and existing relationships with our valued customers and manufacturers. Today with partners in North America, Europe, Asia and South America, we continually work to improve and grow the company. We strive to offer customers exceptional value through our qualified local sales and service representatives who provide convenient access to over 3,500 globally sourced products.

---

Depuis 1951 Omcan a grandi pour devenir un des “leaders” de la distribution des équipements et matériel pour l’industrie des services alimentaires en Amérique du Nord. Notre succès au cours de ces nombreuses années peut être attribué à notre engagement à renforcer et à développer de nouvelles et existantes relations avec nos clients et les fabricants de valeur. Aujourd’hui avec des partenaires en Amérique du Nord, Europe, Asie et Amérique du Sud, nous travaillons continuellement à améliorer et développer l’entreprise. Nous nous efforçons d’offrir à nos clients une valeur exceptionnelle grâce à nos ventes locales qualifiées et des représentants de service qui offrent un accès facile à plus de 3500 produits provenant du monde entier.

---

Desde 1951 Omcan ha crecido hasta convertirse en un líder en la distribución de equipos y suministros de alimentos en América del Norte industria de servicios. Nuestro éxito en estos años se puede atribuir a nuestro compromiso de fortalecer y desarrollar nuevas relaciones existentes con nuestros valiosos clientes y fabricantes. Hoy con socios de América del Norte, Europa, Asia y América del Sur, que trabajan continuamente para mejorar y crecer la empresa. Nos esforzamos por ofrecer a nuestros clientes valor excepcional a través de nuestro local de ventas y representantes de los servicios que proporcionan un fácil acceso a más de 3,500 productos con origen a nivel mundial.

