



**Pizza Warmer**  
**Model DW-CN-0457-SS**  
**Item 41468**  
**Instruction Manual**



*Revised - 09/19/2018*



Toll Free: 1-800-465-0234  
Fax: 905-607-0234  
Email: [service@omcan.com](mailto:service@omcan.com)  
[www.omcan.com](http://www.omcan.com)

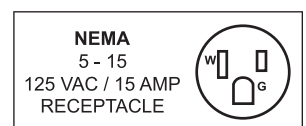

# ***Table of Contents***

Model DW-CN-0457-SS

---

<b>Section</b>	<b>Page</b>
General Information -----	3 - 4
Safety and Warranty -----	4 - 6
Technical Specifications -----	6
Operation -----	7 - 9
Maintenance -----	9
Troubleshooting -----	10
Parts Breakdown -----	11 - 12
Electrical Schematics -----	13
Notes -----	14
Warranty Registration -----	15



# General Information

---

Omcan Manufacturing and Distributing Company Inc., Food Machinery of America, Inc. dba Omcan and Omcan Inc. are not responsible for any harm or injury caused due to any person's improper or negligent use of this equipment. The product shall only be operated by someone over the age of 18, of sound mind, and not under the influence of any drugs or alcohol, who has been trained in the correct operation of this machine, and is wearing authorized, proper safety clothing. Any modification to the machine voids any warranty, and may cause harm to individuals using the machine or in the vicinity of the machine while in operation.

## CHECK PACKAGE UPON ARRIVAL

Upon receipt of an Omcan shipment please inspect for external damage. If no damage is evident on the external packaging, open carton to ensure all ordered items are within the box, and there is no concealed damage to the machine. If the package has suffered rough handling, bumps or damage (visible or concealed), please note it on the bill of lading before accepting the delivery and contact Omcan within 24 hours, so we may initiate a claim with the carrier. A detailed report on the extent of the damage caused to the machine must be filled out within three days, from the delivery date shown in the shipping documents. Omcan has no recourse for damaged products that were shipped collect or third party.

**Before operating any equipment, always read and familiarize yourself with all operation and safety instructions.**

Omcan would like to thank you for purchasing this machine. It's of the utmost importance to save these instructions for future reference. Also save the original box and packaging for shipping the equipment if servicing or returning of the machine is required.

---

Omcan Fabrication et distribution Compagnie Limitée et Food Machinery d'Amérique, dba Omcan et Omcan Inc. ne sont pas responsables de tout dommage ou blessure causé du fait que toute personne ait utilisé cet équipement de façon irrégulière. Le produit ne doit être exploité que par quelqu'un de plus de 18 ans, sain d'esprit, et pas sous l'influence d'une drogue ou d'alcool, qui a été formé pour utiliser cette machine correctement, et est vêtu de vêtements de sécurité appropriés. Toute modification de la machine annule toute garantie, et peut causer un préjudice à des personnes utilisant la machine ou des personnes à proximité de la machine pendant son fonctionnement.

## VÉRIFIEZ LE COLIS DÈS RÉCEPTION

Dès réception d'une expédition d'Omcan veuillez inspecter pour dommages externes. Si aucun dommage n'est visible sur l'emballage externe, ouvrez le carton afin de s'assurer que tous les éléments commandés sont dans la boîte, et il n'y a aucun dommage dissimulé à la machine. Si le colis n'a subi aucune mauvaises manipulations, de bosses ou de dommages (visible ou cachée), notez-le sur le bond de livraison avant d'accepter la livraison et contactez Omcan dans les 24 heures qui suivent, pour que nous puissions engager une réclamation auprès du transporteur. Un rapport détaillé sur l'étendue des dommages causés à la machine doit être rempli dans un délai de trois jours, à compter de la date de livraison indiquée dans les documents d'expédition. Omcan n'a aucun droit de recours pour les produits endommagés qui ont été expédiés ou cueilli par un tiers transporteur.

# General Information

---

Avant d'utiliser n'importe quel équipement, toujours lire et vous familiariser avec toutes les opérations et les consignes de sécurité.

Omcan voudrais vous remercier d'avoir choisi cette machine. Il est primordial de conserver ces instructions pour une référence ultérieure. Également conservez la boîte originale et l'emballage pour l'expédition de l'équipement si l'entretien ou le retour de la machine est nécessaire.

---

Omcan Empresa De Fabricacion Y Distribucion Inc. Y Maquinaria De Alimentos De America, Inc. dba Omcan y Omcan Inc. no son responsables de ningun daño o perjuicio causado por cualquier persona inadecuada o el uso descuidado de este equipo. El producto solo podra ser operado por una persona mayor de 18 años, en su sano juicio y no bajo alguna influencia de droga o alcohol, y que este ha sido entrenado en el correcto funcionamiento de esta máquina, y ésta usando ropa apropiada y autorizada. Cualquier modificación a la máquina anula la garantía y puede causar daños a las personas usando la máquina mientras esta en el funcionamiento.

## REVISE EL PAQUETE A SU LLEGADA

Tras la recepcion de un envio Omcan favor inspeccionar daños externos. Si no hay daños evidentes en el empaque exterior, Habra el carton para asegurarse que todos los articulos solicitados estén dentro de la caja y no encuentre daños ocultos en la máquina. Si el paquete ha sufrido un manejo de poco cuidado, golpes o daños (visible o oculto) por favor anote en la factura antes de aceptar la entrega y contacte Omcan dentro de las 24 horas, de modo que podamos iniciar una reclamación con la compañía. Un informe detallado sobre los daños causados a la máquina debe ser llenado en el plazo de tres días, desde la fecha de entrega que se muestra en los documentos de envío. Omcan no tiene ningun recurso por productos dañados que se enviaron a recoger por terceros.

Antes de utilizar cualquier equipo, siempre lea y familiarizarse con todas las instrucciones de funcionamiento y seguridad.

Omcan le gustaría darle las gracias por la compra de esta máquina. Es de la mayor importancia para salvar estas instrucciones para futuras consultas. Además, guarda la caja original y el embalaje para el envío del equipo si servicio técnico o devolución de la máquina que se requiere.

# Safety and Warranty

---

## WARNING

1. If the supply cord is damaged it must be replaced by Omcan, or a qualified service agent in order to avoid any electrical hazards.
2. This appliance shall not be cleaned with any type of liquid pressurized cleaning equipment.
3. This appliance is not intended for use by persons (including children) with reduced physical, sensory or mental capabilities, or lack of experience and knowledge, unless they have been given specific instruction

# Safety and Warranty

---

with proper supervision concerning the use of this appliance.

4. Under no circumstances should any children be allowed to operate this equipment unless properly supervised.
5. This equipment comes with a properly grounded power cord. All power receptacles should be installed with a properly installed grounded circuit.

## SAFE OPERATION NOTICE

- All operators must strictly observe and follow local state or provincial electrical safety codes and guidelines.
- This unit must be used by qualified and trained personnel at all times. Staff should be instructed on proper daily operation and maintenance prior to usage.
- Before operating machine, ensure that all covers, doors and moving components are installed properly and working prior to usage. This will ensure unit is in safe operating order and provide years of long lasting service.

### Warranty does not apply to the following conditions:

- Improper uses other than what the unit was originally designed.
- In the case of damaged parts, do not continue to use the unit as you will void the warranty. Contact Omcan or your local dealer.
- Neglect and improper operating procedures during installation and or in transportation, commissioning, maintenance or repair.
- All warranty repairs must be authorized by the original manufacture by means of written consent.
- Warranty parts can be supplied and installed by means of a authorized service agent hired or contracted by Omcan only. Unauthorized service will void all warranties without prior written consent from Omcan.
- Improper daily maintenance.
- Use of Force Majeure.

## ELECTRICAL

When first installed, ensure proper power requirements are met. A standard 15A / 110-120V grounded receptacle must be utilized.

## 1 YEAR PARTS AND LABOUR BENCH WARRANTY

Within the warranty period, contact Omcan Inc. at 1-800-465-0234 to schedule a drop off to either an Omcan authorized service depot in the area, or to an Omcan Service warehouse to repair the equipment.

Unauthorized maintenance will void the warranty. Warranty covers electrical and part failures, not improper use.

Please see <https://omcan.com/disclaimer> for complete info.

# Safety and Warranty

---

## WARNING:

The packaging components are classified as normal solid urban waste and can therefore be disposed of without difficulty.

In any case, for suitable recycling, we suggest disposing of the products separately (differentiated waste) according to the current norms.

**DO NOT DISCARD ANY PACKAGING MATERIALS IN THE ENVIRONMENT!**

# Technical Specifications

---

This pizza warmer is mainly utilized in commercial spaces such as fast-food restaurants, convenience stores along with self-service restaurants and supermarkets.

## FEATURES OF OUR PRODUCTS

- The unit comes with two florescent lighting fixtures which increases the view ability of the product being displayed.
- The unit also features adjustable humidity and heat controls which allow greater flexibility to improve overall product freshness and consistency.
- The unit thermostat control allows for even heat during the warming period on all food surfaces.

## TECHNICAL SPECIFICATIONS

<b>Model</b>	<b>DW-CN-0457-SS</b>
<b>Power</b>	1.7 kW
<b>Temperature</b>	30°C - 90°C / 86°F - 194°F
<b>Interior Lights</b>	11W
<b>Electrical</b>	110V / 60Hz / 1
<b>Maximum Pizza Size</b>	18" / 457mm Diameter
<b>Dimensions</b>	23.6" x 23.6" x 27.6" / 599 x 599 x 701mm
<b>Weight</b>	70.4 lbs. / 31.9 kgs.
<b>Item Number</b>	41468

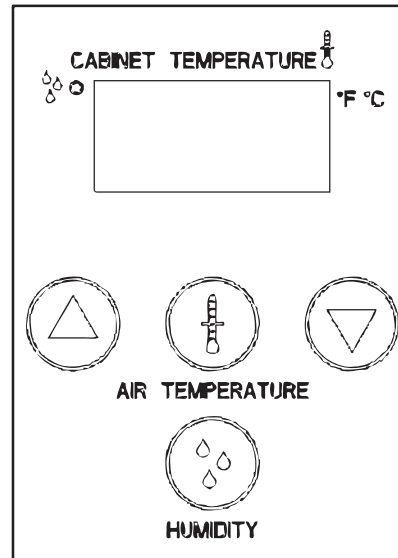

### To start:

1. Put plug in power source.
2. Turn the power switch to the "I" position.
  - The display will light up and the heating element will start.
  - "LO H2O" will flash once on the display until water tank is filled with water. Once the tank is full, "LO H2O" will stop flashing and the display will show cabinet temperature.
3. Fill the tank up with water.
  - Turn up the tank cover.
  - Inject water until "LO H2O" stops flashing.

**Note: Don't inject water excessively.**
4. Set the humidity parameters as required.
5. Set the temperature parameters as required.
6. Please wait 20 minutes before you put food into the machine.

### SET TEMPERATURE

1. Press the "⏻" button to start (the display will show "tSP").
  2. Press the "⏻" button again, the display will show current cabinet temperature.
  3. Press "▲" or "▼" to modify the temperature. The range is 26°C to 90°C.
  4. Don't press any buttons for 15 seconds, so the temperature setting will be stored. The display will come back to normal mode.
- Note: The temperature values are set to °F when first received, to change between °F and °C please follow the below instructions.**

### TO CHANGE THE TEMPERATURE VALUES FROM °F - °C

#### CAUTION

Ensure that the unit is turned off and removed from it's power source before starting this process.

1. Remove the three screws from the top cover of the machine.

# Operation

2. Remove the light tube and its left bracket (Fig. 1).
3. Remove the six screws from the black control box, then remove the cover of the black control box.
4. Locate the switch on the circuit board that shows °F and °C. Switch that part only to change the values from F to C (Fig. 2).
5. Reassemble the machine by following these instructions in reverse order.

**Note: please revisit these instructions if you need to change the values back to °F.**





FIG. 1

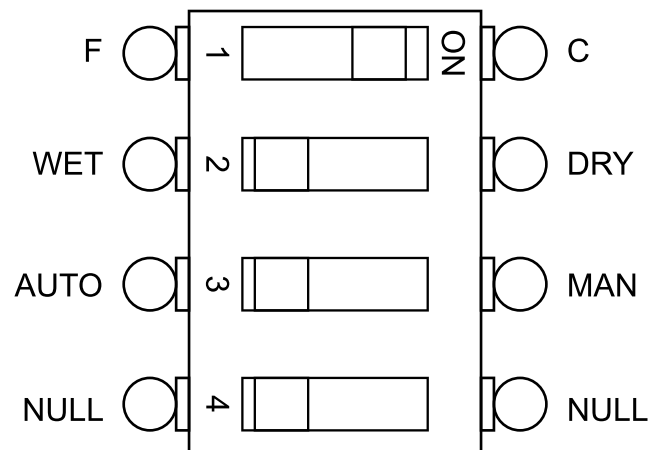
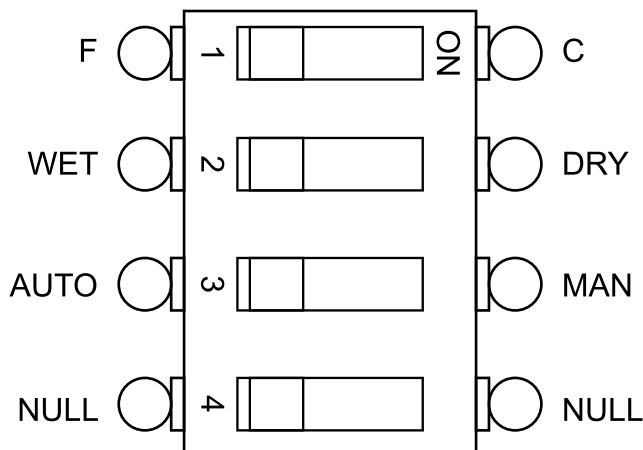

FIG. 2



## SET HUMIDITY

1. Press the “” button to start (the display will show “hSP”).
2. Press the “” button again, the display will show current cabinet humidity.
3. Press “” or “” to modify the humidity. The range is 1 to 5.
4. Don't press any buttons for 15 seconds, so the humidity setting will be stored. The display will come back to normal mode.

## NOTES

Different kind of food will affect temperature and humidity setting. Temperature on display is the lowest temperature in cabinet, not food temperature.

Full-injected water tank can continuously work for 3 to 6 hours. Working time depends on the different parameter setting, ambient humidity and frequency of door opening. When the display flashes “LO H2O” please add water immediately!

## Maintenance

- Daily maintenance should be carried out with all power to the unit in the off position, and the electrical cord unplugged. Cleaning should be carried out by means of food grade cleaning solutions via a soft or damp cloth. Do not utilize any type of pressurized water equipment.
- Regular inspection on the outside and internal cabinet along with the power cord should be observed and carried out on a regular basis to isolate and or observe any unforeseen failure or safety concern.

## CLEANING AND INSTALL ROTARY SHELF

1. Open glass door.
2. Loosen top screws.
3. Take out the rotary shelf.

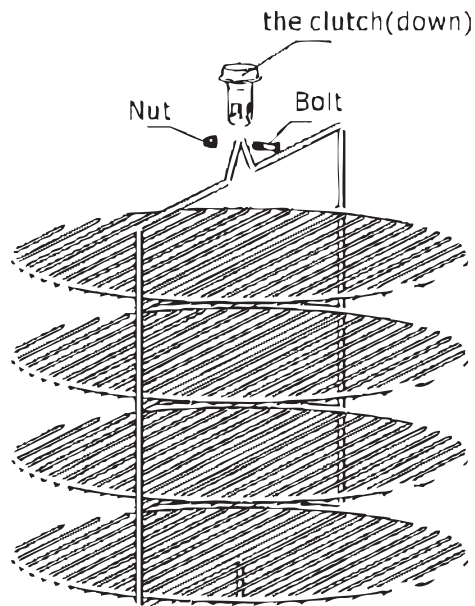

**Warning:** cleaning outside and inside the cabinet must be made with the power off at all times.

# Troubleshooting

Problem	Possible Cause	Solution
No lighting in the interior cabinet.	No power.	Inspect power source.
	Florescent lamps failure.	Replace fluorescent tubes.
Rotating shelf has stopped.	Motor damage.	Replace motor.
	Front door not completely closed.	Close front door / check magnetic door sensor.
Interior cabinet heat is not warming up.	Thermostat off.	Dial in temperature.
	Thermostat or heater coil failure.	Contact Omcan.

## REFERENCE

Item Number	Model Number	Description	Manufacturer Model Number
41468	DW-CN-0457-SS	Display Warmer Pizza 18" / 457mm Diameter Stainless Steel 110V/60/1 cQPSus	RTR-158L

# Parts Breakdown

Model DW-CN-0457-SS 41468

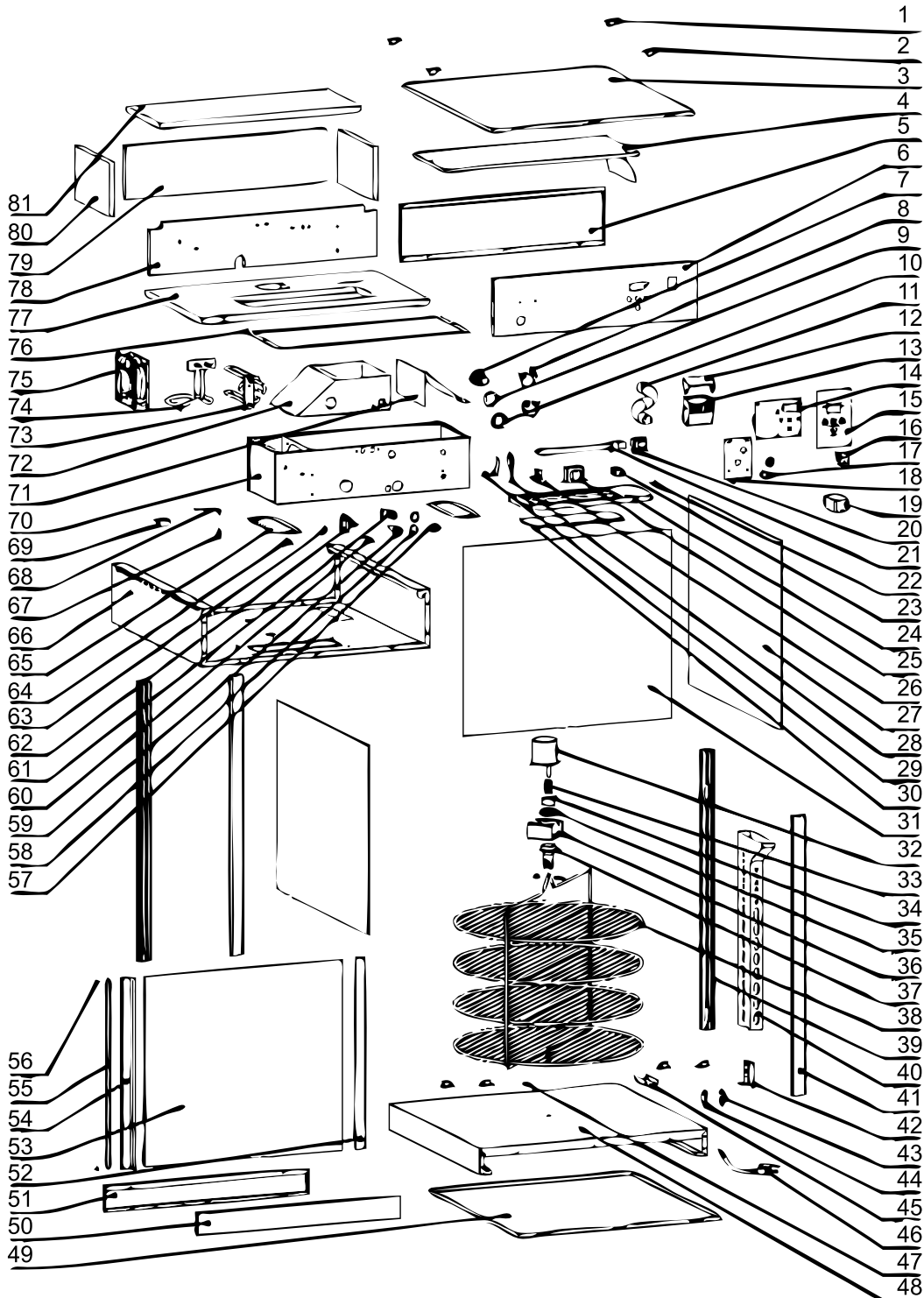

# Parts Breakdown

## Model DW-CN-0457-SS 41468

Item No.	Description	Position	Item No.	Description	Position	Item No.	Description	Position
42395	Left Feet for RTR-158L	1	42422	Micro Switch for RTR-158L	28	42450	Door Magnet Strip for RTR-158L	55
42396	Right Feet for RTR-158L	2	42423	Micro Switch Bracket for RTR-158L	29	42451	Magnet for RTR-158L	56
42397	Top Cover for RTR-158L	3	42424	Top Light Glass for RTR-158L	30	42452	Controller for RTR-158L	57
42398	U Cover for RTR-158L	4	42425	Back Glass for RTR-158L	31	42453	Screws for RTR-158L	58
42399	Rear Top Cover for RTR-158L	5	42426	Motor for RTR-158L	32	42454	Water Level Sensor (Lower) for RTR-158L	59
42400	Front Top Cover for RTR-158L	6	42427	Spring for RTR-158L	33	42455	Temperature Sensor for RTR-158L	60
42401	Screw for RTR-158L	7	42428	Upper Clutch for RTR-158L	34	42456	Water Level Sensor (Upper) for RTR-158L	61
42402	Clip for RTR-158L	8	42429	Bearing for RTR-158L	35	42457	Drain Valve for RTR-158L	62
42403	O Ring for RTR-158L	9	42430	Motor Bracket for RTR-158L	36	42458	Rubber Ring for RTR-158L	63
42404	Screw Nut for RTR-158L	10	42431	Lower Clutch for RTR-158L	37	42459	Temperature Sensor for RTR-158L	64
42405	Inlet Pipe for RTR-158L	11	42432	Rotary Shelf for RTR-158L	38	42460	Seal for RTR-158L	65
42406	Infall Box Cover for RTR-158L	12	42433	Rear Pillar for RTR-158L	39	42461	Top Panel for RTR-158L	66
42407	Infall Box for RTR-158L	13	42434	Wind-Guiding Path for RTR-158L	40	42462	Door Pin for RTR-158L	67
42408	Circuit Board for RTR-158L	14	42435	Front Pillar for RTR-158L	41	42463	Door Gemel for RTR-158L	68
42409	Operation Sticker for RTR-158L	15	42436	Wires Clip Holder for RTR-158L	42	42464	Door Stopper for RTR-158L	69
42410	On / Off Switch for RTR-158L	16	42437	Wires Clip for RTR-158L	43	42465	U Box for RTR-158L	70
42411	Rubber Ring for RTR-158L	17	42438	Wires Clip Cover for RTR-158L	44	42466	U Wind-Guiding Panel for RTR-158L	71
42412	Bracket for RTR-158L	18	42439	Wind-Guiding Path Bucket for RTR-158L	45	42468	Water Tray for RTR-158L	72
42413	Ballast for RTR-158L	19	42440	American Power Line for RTR-158L	46	42469	Heating Element 1 for RTR-158L	73
42414	Lamp Holder for RTR-158L	20	42442	Shelf Bearing for RTR-158L	47	42470	Heating Element 2 for RTR-158L	74
42415	Light Tube for RTR-158L	21	42443	Bottom Cover for RTR-158L	48	42472	Fan Motor for RTR-158L	75
42416	Capacity for RTR-158L	22	42444	Bottom Board for RTR-158L	49	42473	Seal for RTR-158L	76
42417	Terminal for RTR-158L	23	42445	Front Bottom Panel for RTR-158L	50	42474	Bottom Insulation for RTR-158L	77
42418	Light Glass Plate for RTR-158L	24	42446	Rear Bottom Panel for RTR-158L	51	42478	Front Insulation for RTR-158L	78
42419	Transformer for RTR-158L	25	42447	Door Frame for RTR-158L	52	42479	Rear Insulation for RTR-158L	79
42420	Light Tube Bracket for RTR-158L	26	42448	Door Glass for RTR-158L	53	42480	Side Insulation for RTR-158L	80
42421	Side Glass for RTR-158L	27	42449	Door Handle for RTR-158L	54	42481	Top Insulation for RTR-158L	81

# Electrical Schematics

Model DW-CN-0457-SS 41468

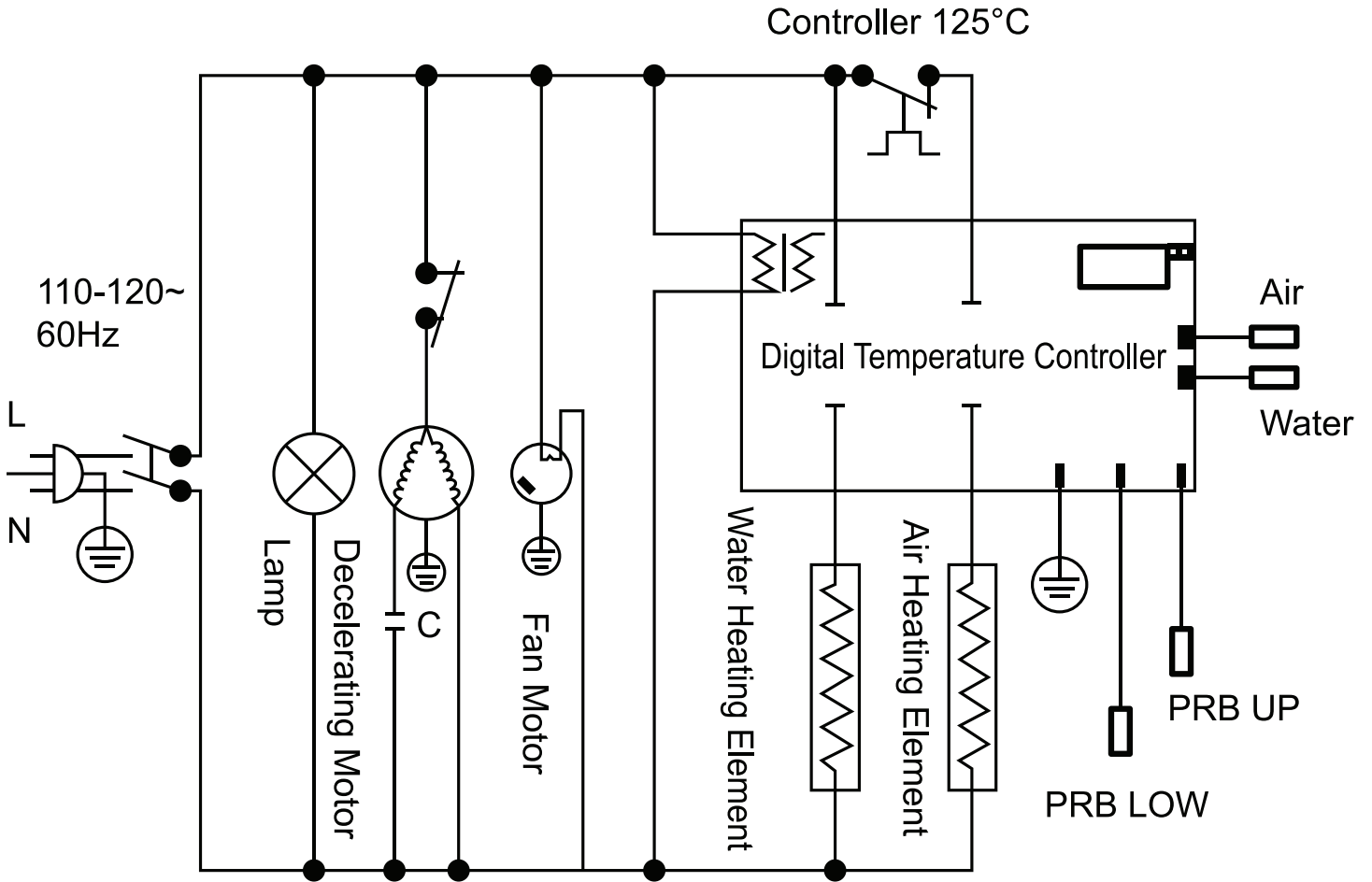





# Warranty Registration

Thank you for purchasing an Omcan product. To register your warranty for this product, complete the information below, tear off the card at the perforation and then send to the address specified below. You can also register online by visiting:

Merci d'avoir acheté un produit Omcan. Pour enregistrer votre garantie pour ce produit, complétez les informations ci-dessous, détachez la carte au niveau de la perforation, puis l'envoyer à l'adresse spécifiée ci-dessous. Vous pouvez également vous inscrire en ligne en visitant:

Gracias por comprar un producto Omcan usted. Para registrar su garantía para este producto, complete la información a continuación, cortar la tarjeta en la perforación y luego enviarlo a la dirección indicada a continuación. También puede registrarse en línea en:

<https://omcan.com/warranty-registration/>

For mailing in Canada

Pour postale au Canada

Por correo en Canadá

**OMCAN**

PRODUCT WARRANTY REGISTRATION

3115 Pepper Mill Court,

Mississauga, Ontario

Canada, L5L 4X5

For mailing in the US

Pour diffusion aux États-Unis

Por correo en los EE.UU.

**OMCAN**

PRODUCT WARRANTY REGISTRATION

4450 Witmer Industrial Estates, Unit 4,

Niagara Falls, New York

USA, 14305

*or email to: [service@omcan.com](mailto:service@omcan.com)*



Purchaser's Information

Name: \_\_\_\_\_

Address: \_\_\_\_\_

City: \_\_\_\_\_ Province or State: \_\_\_\_\_ Postal or Zip: \_\_\_\_\_

Country: \_\_\_\_\_

Dealer from which Purchased: \_\_\_\_\_

Dealer City: \_\_\_\_\_ Dealer Province or State: \_\_\_\_\_

Invoice: \_\_\_\_\_

Model Name: \_\_\_\_\_ Model Number: \_\_\_\_\_

Machine Description: \_\_\_\_\_

Date of Purchase (MM/DD/YYYY): \_\_\_\_\_

Would you like to extend the warranty?  Yes  No

Company Name: \_\_\_\_\_

Telephone: \_\_\_\_\_

Email Address: \_\_\_\_\_

Type of Company:

Restaurant  Bakery  Deli

Butcher  Supermarket  Caterer

Institution (*specify*): \_\_\_\_\_

Other (*specify*): \_\_\_\_\_

Serial Number: \_\_\_\_\_

Date of Installation (MM/DD/YYYY): \_\_\_\_\_

**Thank you for choosing Omcan | Merci d'avoir choisi Omcan | Gracias por elegir Omcan**



Since 1951 Omcan has grown to become a leading distributor of equipment and supplies to the North American food service industry. Our success over these many years can be attributed to our commitment to strengthen and develop new and existing relationships with our valued customers and manufacturers. Today with partners in North America, Europe, Asia and South America, we continually work to improve and grow the company. We strive to offer customers exceptional value through our qualified local sales and service representatives who provide convenient access to over 5,000 globally sourced products.

---

Depuis 1951 Omcan a grandi pour devenir un des “leaders” de la distribution des équipements et matériel pour l’industrie des services alimentaires en Amérique du Nord. Notre succès au cours de ces nombreuses années peut être attribué à notre engagement à renforcer et à développer de nouvelles et existantes relations avec nos clients et les fabricants de valeur. Aujourd’hui avec des partenaires en Amérique du Nord, Europe, Asie et Amérique du Sud, nous travaillons continuellement à améliorer et développer l’entreprise. Nous nous efforçons d’offrir à nos clients une valeur exceptionnelle grâce à nos ventes locales qualifiées et des représentants de service qui offrent un accès facile à plus de 5000 produits provenant du monde entier.

---

Desde 1951 Omcan ha crecido hasta convertirse en un líder en la distribución de equipos y suministros de alimentos en América del Norte industria de servicios. Nuestro éxito en estos años se puede atribuir a nuestro compromiso de fortalecer y desarrollar nuevas relaciones existentes con nuestros valiosos clientes y fabricantes. Hoy con socios de América del Norte, Europa, Asia y América del Sur, que trabajan continuamente para mejorar y crecer la empresa. Nos esforzamos por ofrecer a nuestros clientes valor excepcional a través de nuestro local de ventas y representantes de los servicios que proporcionan un fácil acceso a más de 5,000 productos con origen a nivel mundial.

