



8-Liter Bowl Cutter
Models FP-CN-0008, 0008-B
Items 16998, 16999
Instruction Manual



Revised - 12/27/2017



Toll Free: 1-800-465-0234
Fax: 905-607-0234
Email: service@omcan.com
www.omcan.com

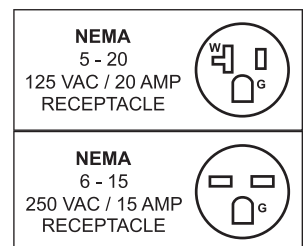

Table of Contents

Model FP-CN-0008 / Model FP-CN-0008-B

Section	Page
General Information -----	3 - 4
Safety and Warranty -----	4 - 5
Technical Specifications -----	6
Operation -----	6
Maintenance -----	6 - 7
Parts Breakdown -----	8 - 9
Electrical Schematics -----	10
Warranty Registration -----	11



General Information

Omcan Manufacturing and Distributing Company Inc., Food Machinery of America, Inc. dba Omcan and Omcan Inc. are not responsible for any harm or injury caused due to any person's improper or negligent use of this equipment. The product shall only be operated by someone over the age of 18, of sound mind, and not under the influence of any drugs or alcohol, who has been trained in the correct operation of this machine, and is wearing authorized, proper safety clothing. Any modification to the machine voids any warranty, and may cause harm to individuals using the machine or in the vicinity of the machine while in operation.

CHECK PACKAGE UPON ARRIVAL

Upon receipt of an Omcan shipment please inspect for external damage. If no damage is evident on the external packaging, open carton to ensure all ordered items are within the box, and there is no concealed damage to the machine. If the package has suffered rough handling, bumps or damage (visible or concealed), please note it on the bill of lading before accepting the delivery and contact Omcan within 24 hours, so we may initiate a claim with the carrier. A detailed report on the extent of the damage caused to the machine must be filled out within three days, from the delivery date shown in the shipping documents. Omcan has no recourse for damaged products that were shipped collect or third party.

Before operating any equipment, always read and familiarize yourself with all operation and safety instructions.

Omcan would like to thank you for purchasing this machine. It's of the utmost importance to save these instructions for future reference. Also save the original box and packaging for shipping the equipment if servicing or returning of the machine is required.

Omcan Fabrication et distribution Compañie Limité et Food Machinery d'Amérique, dba Omcan et Omcan Inc. ne sont pas responsables de tout dommage ou blessure causé du fait que toute personne ait utilisé cet équipement de façon irrégulière. Le produit ne doit être exploité que par quelqu'un de plus de 18 ans, saine d'esprit, et pas sous l'influence d'une drogue ou d'alcool, qui a été formé pour utiliser cette machine correctement, et est vêtu de vêtements de sécurité approprié. Toute modification de la machine annule toute garantie, et peut causer un préjudice à des personnes utilisant la machine ou des personnes à proximité de la machine pendant son fonctionnement.

VÉRIFIEZ LE COLIS DÈS RÉCEPTION

Dès réception d'une expédition d'Omcan veuillez inspecter pour dommages externes. Si aucun dommage n'est visible sur l'emballage externe, ouvrez le carton afin de s'assurer que tous les éléments commandés sont dans la boîte, et il n'y a aucun dommage dissimulé à la machine. Si le colis n'a subi aucune mauvaises manipulations, de bosses ou de dommages (visible ou cachée), notez-le sur le bond de livraison avant d'accepter la livraison et contactez Omcan dans les 24 heures qui suivent, pour que nous puissions engager une réclamation auprès du transporteur. Un rapport détaillé sur l'étendue des dommages causés à la machine doit être rempli dans un délai de trois jours, à compter de la date de livraison indiquée dans les documents d'expédition. Omcan n'a aucun droit de recours pour les produits endommagés qui ont été expédiées ou cueilli par un tiers transporteur.

General Information

Avant d'utiliser n'importe quel équipement, toujours lire et vous familiariser avec toutes les opérations et les consignes de sécurité.

Omcan voudrais vous remercier d'avoir choisi cette machine. Il est primordial de conserver ces instructions pour une référence ultérieure. Également conservez la boîte originale et l'emballage pour l'expédition de l'équipement si l'entretien ou le retour de la machine est nécessaire.

Omcan Empresa De Fabricacion Y Distribucion Inc. Y Maquinaria De Alimentos De America, Inc. dba Omcan y Omcan Inc. no son responsables de ningun daño o perjuicio causado por cualquier persona inadecuada o el uso descuidado de este equipo. El producto solo podra ser operado por una persona mayor de 18 años, en su sano juicio y no bajo alguna influencia de droga o alcohol, y que este ha sido entrenado en el correcto funcionamiento de esta máquina, y ésta usando ropa apropiada y autorizada. Cualquier modificación a la máquina anula la garantía y puede causar daños a las personas usando la máquina mientras esta en el funcionamiento.

REVISE EL PAQUETE A SU LLEGADA

Tras la recepcion de un envio Omcan favor inspeccionar daños externos. Si no hay daños evidentes en el empaque exterior, Habra el carton para asegurarse que todos los articulos solicitados estén dentro de la caja y no encuentre daños ocultos en la máquina. Si el paquete ha sufrido un manejo de poco cuidado, golpes o daños (visible o oculto) por favor anote en la factura antes de aceptar la entrega y contacte Omcan dentro de las 24 horas, de modo que podamos iniciar una reclamación con la compañía. Un informe detallado sobre los daños causados a la máquina debe ser llenado en el plazo de tres días, desde la fecha de entrega que se muestra en los documentos de envío. Omcan no tiene ningun recurso por productos dañados que se enviaron a recoger por terceros.

Antes de utilizar cualquier equipo, siempre lea y familiarizarse con todas las instrucciones de funcionamiento y seguridad.

Omcan le gustaría darle las gracias por la compra de esta máquina. Es de la mayor importancia para salvar estas instrucciones para futuras consultas. Además, guarda la caja original y el embalaje para el envío del equipo si servicio técnico o devolución de la máquina que se requiere.

Safety and Warranty

WARNING

PLEASE READ THE USER MANUAL CAREFULLY BEFORE OPERATING THE MACHINE

- New user or repairing this product must be performed by the experts or qualified person or those who have gotten the license of installation, or those who are authorized by the manufacturer.
- When installation or maintenance, please obey the following instructions carefully to ensure the safety use of this appliance.

Safety and Warranty

- Please keep this instruction manual for future reference, or hand it to next user.
- Put off the package to make sure none of the parts is missing or damaged. If there is any doubt about the product, please do not use it, and consult it to the experts.
- Keep the packing material out of reach of the children to avoid accident (especially the plastic bag, screw, etc).
- This appliance could be only operated by the person who is familiar with the unit.
- When not using the appliance or the operator is absent, please turn off the unit to avoid any accidental injury or damage.
- When it needs to be repaired, please ask for expert, and use the original fitted spare part. It will be dangerous if the above requirements are not being followed.
- This appliance is just for commercial using, not for any other use. Otherwise, it may be dangerous.
- Do not rinse the equipment with water directly.
- Clean the surface of stainless steel periodically with appropriate method to prevent any damage brought by oxidization or any other chemical interference.

1 YEAR PARTS AND LABOUR WARRANTY

Within the warranty period, contact Omcan Inc. at 1-800-465-0234 to schedule an Omcan authorized service technician to repair the equipment locally.

Unauthorized maintenance will void the warranty. Warranty covers electrical and part failures, not improper use.

Please see www.omcan.com/warranty.html for complete info.

WARNING:

The packaging components are classified as normal solid urban waste and can therefore be disposed of without difficulty.

In any case, for suitable recycling, we suggest disposing of the products separately (differentiated waste) according to the current norms.

DO NOT DISCARD ANY PACKAGING MATERIALS IN THE ENVIRONMENT!

Technical Specifications

Model	FP-CN-0008	FP-CN-0008-B
Power	1 HP / 0.75 kW	
Capacity	8 L / 2 gal	
Bowl Dimension	18" / 457mm Diameter x 4" / 102mm Depth	
Productivity	120 kg/h	
RPM	1400	
Electrical	110V / 60Hz / 1Ph	220V / 60Hz / 1Ph
Weight	198 lbs. / 90 kgs.	
Packaging Weight	220 lbs. / 98 kgs.	
Packaging Dimensions	34" x 25" x 26" / 864 x 635 x 660mm	
Item Number	16998	16999

Operation

Before use, check that power supply corresponds to that required by the machine, and the machine must be grounded. Check the fixed nut of blade and tighten it. Cut meat into pieces, suiting the feed-size. Feed the pieces in order, and keep the work smoothly. After use, disconnect from the electricity supply, discharge the top cover, and wash blades, as to avoid bacteria growth. Do not flow water into the bearing and motor. Lubricate the bearings and gears occasionally.

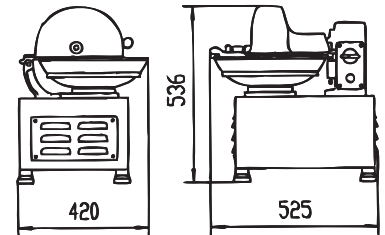

Maintenance

- Always turn the machine off before proceeding with its cleaning. Disconnect the machine from the main power source and deactivate power on breaker panel. The machine should be cleaned daily, both before and after its use. Given the easy access to all its components, the cutter/chopper is simple to clean using just warm water and a mild detergent.
- Never use bleach nor any abrasive cleaners which could damage the stainless steel or other materials.
- Never use steam or a high pressure jet of water to clean the cutter/chopper; avoid getting water in the interior of the machine, especially through or around any electrical components.
- After every operating session, use a brush to carefully clean the bowl, the knife shaft, and the interior part of the knife lid, the hinge of the lid, and the lid holding screws if necessary.
- Do not put your hands near the cutting edge of the knives without using adequate protection (gloves made of reinforced metal fiber).
- The knife head can be removed in one piece in order to clean it under running water; take care not to drop the knife head assemblage on the floor or on your feet.

Maintenance

- Do not wash the knives in water hotter than 60°C or colder than 10°C. Do not wash the knives immediately after using the machine since an abrupt change in temperature could cause internal micro fissures or deformations.
- It is extremely important to keep the surfaces holding the knives and separation rings clean to avoid build-up of mixture residues. Such a build-up could create areas which bear more pressure than others, possibly causing micro fissures that could damage or break the knife.
- To clean the machine manually, always use appropriate safety equipment (latex gloves, plastic aprons).
- Always rinse the machine thoroughly after using any kind of detergent or disinfectant and be sure to follow the manufacturers' instructions when using cleaning products.

Parts Breakdown

Model FP-CN-0008 16998

Model FP-CN-0008-B 16999

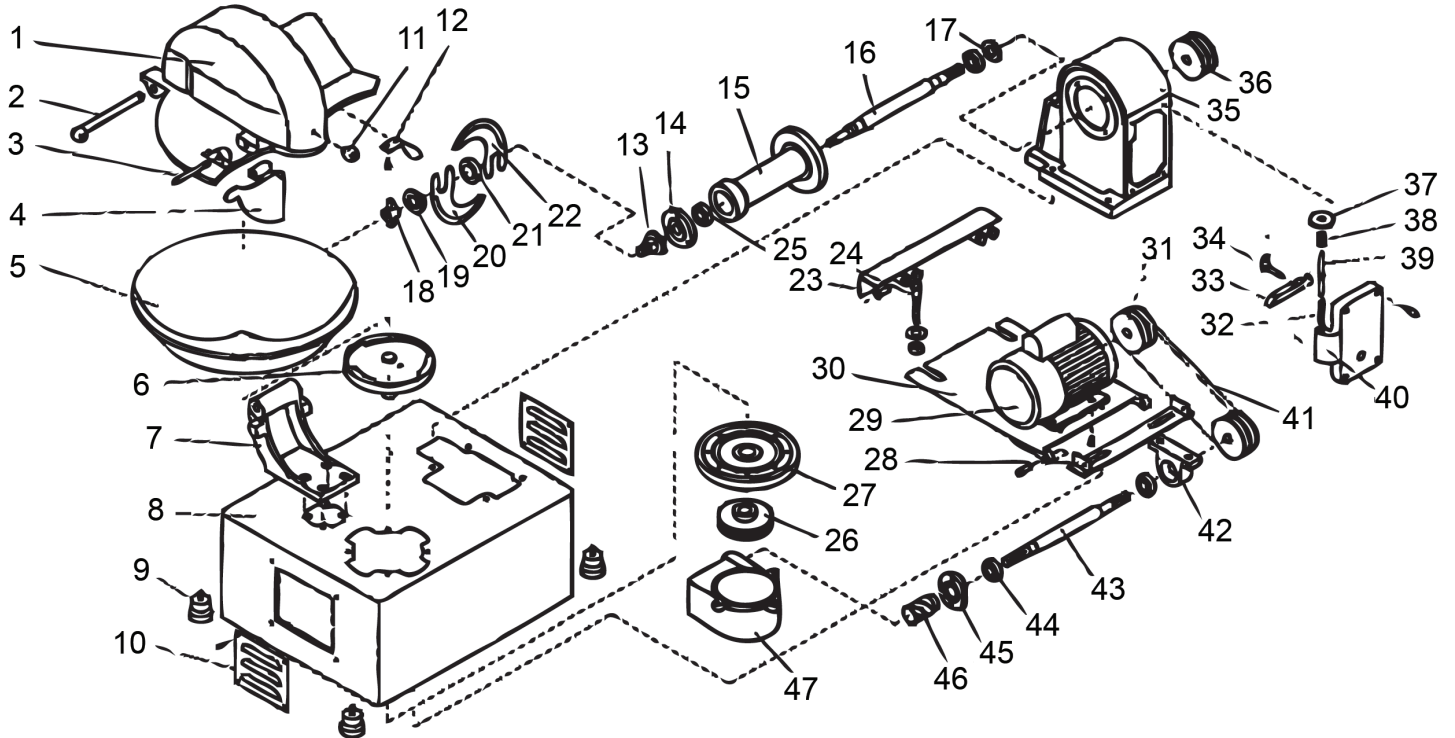



Parts Breakdown

Model FP-CN-0008 16998

Item No.	Description	Position	Item No.	Description	Position	Item No.	Description	Position
43031	Cover for TQ8A11060	1	76866	Through Axle Elastic Washer 17 for TQ8A11060	17	76881	Press Arm for TQ8A11060	33
76852	Cover Shaft for TQ8A11060	2	76867	Binding Nut for TQ8A11060	18	76882	Fork Catch for TQ8A11060	34
76853	Discharge Plate Shaft for TQ8A11060	3	76868	Nut for TQ8A11060	19	76883	Blade Barrel for TQ8A11060	35
76854	Discharge Plate for TQ8A11060	4	20044	One-Edged Knife for TQ8A11060	20	76884	Belt Pulley for TQ8A11060	36
31408	Bowl for TQ8A11060	5	76869	Insulated Ring for TQ8A11060	21	76885	Blocking Nut for TQ8A11060	37
76855	Bowl Support for TQ8A11060	6	76870	Double-Edged Knife for TQ8A11060	22	76886	Screw Barrel for TQ8A11060	38
76856	Cover Support for TQ8A11060	7	76871	Installing Support II for TQ8A11060	23	76887	Steady Arm for TQ8A11060	39
76857	Body for TQ8A11060	8	76872	Hinge for TQ8A11060	24	76888	Switch Control Panel for TQ8A11060	40
76858	Foot for TQ8A11060	9	76873	Bearing 203 for TQ8A11060	25	76889	VA Belt L 750 for TQ8A11060	41
76859	Vent for TQ8A11060	10	76874	Worm Wheel for TQ8A11060	26	76890	Bearing Seat for TQ8A11060	42
76860	Cover Handle for TQ8A11060	11	76875	Blade Barrel for TQ8A11060	27	76891	Worm Drive Shaft for TQ8A11060	43
76861	Scraper for TQ8A11060	12	76876	Installing Support I for TQ8A11060	28	76892	Bearing 202 for TQ8A11060	44
76862	Blade Seat for TQ8A11060	13	76877	Motor for TQ8A11060	29	76893	Bearing Cover for TQ8A11060	45
76863	Bearing Cover for TQ8A11060	14	76878	Installing Panel for TQ8A11060	30	76894	Worm for TQ8A11060	46
76864	Barrel for TQ8A11060	15	76879	Belt Wheel of Motor for TQ8A11060	31	76895	Worm-Wheel Cover for TQ8A11060	47
76865	Blade Shaft for TQ8A11060	16	76880	Spring for TQ8A11060	32			

Model FP-CN-0008-B 16999

Item No.	Description	Position	Item No.	Description	Position	Item No.	Description	Position
43031	Cover for TQ8A22060	1	76866	Through Axle Elastic Washer 17 for TQ8A22060	17	76881	Press Arm for TQ8A22060	33
76852	Cover Shaft for TQ8A22060	2	76867	Binding Nut for TQ8A22060	18	76882	Fork Catch for TQ8A22060	34
76853	Discharge Plate Shaft for TQ8A22060	3	76868	Nut for TQ8A22060	19	76883	Blade Barrel for TQ8A22060	35
76854	Discharge Plate for TQ8A22060	4	20044	One-Edged Knife for TQ8A22060	20	76884	Belt Pulley for TQ8A22060	36
31408	Bowl for TQ8A22060	5	76869	Insulated Ring for TQ8A22060	21	76885	Blocking Nut for TQ8A22060	37
76855	Bowl Support for TQ8A22060	6	76870	Double-Edged Knife for TQ8A22060	22	76886	Screw Barrel for TQ8A22060	38
76856	Cover Support for TQ8A22060	7	76871	Installing Support II for TQ8A22060	23	76887	Steady Arm for TQ8A22060	39
76857	Body for TQ8A22060	8	76872	Hinge for TQ8A22060	24	76888	Switch Control Panel for TQ8A22060	40
76858	Foot for TQ8A22060	9	76873	Bearing 203 for TQ8A22060	25	76889	VA Belt L 750 for TQ8A22060	41
76859	Vent for TQ8A22060	10	76874	Worm Wheel for TQ8A22060	26	76890	Bearing Seat for TQ8A22060	42
76860	Cover Handle for TQ8A22060	11	76875	Blade Barrel for TQ8A22060	27	76891	Worm Drive Shaft for TQ8A22060	43
76861	Scraper for TQ8A22060	12	76876	Installing Support I for TQ8A22060	28	76892	Bearing 202 for TQ8A22060	44
76862	Blade Seat for TQ8A22060	13	64198	Motor for TQ8A22060	29	76893	Bearing Cover for TQ8A22060	45
76863	Bearing Cover for TQ8A22060	14	76878	Installing Panel for TQ8A22060	30	76894	Worm for TQ8A22060	46
76864	Barrel for TQ8A22060	15	76879	Belt Wheel of Motor for TQ8A22060	31	76895	Worm-Wheel Cover for TQ8A22060	47
76865	Blade Shaft for TQ8A22060	16	76880	Spring for TQ8A22060	32			

Electrical Schematics

Model FP-CN-0008 16998

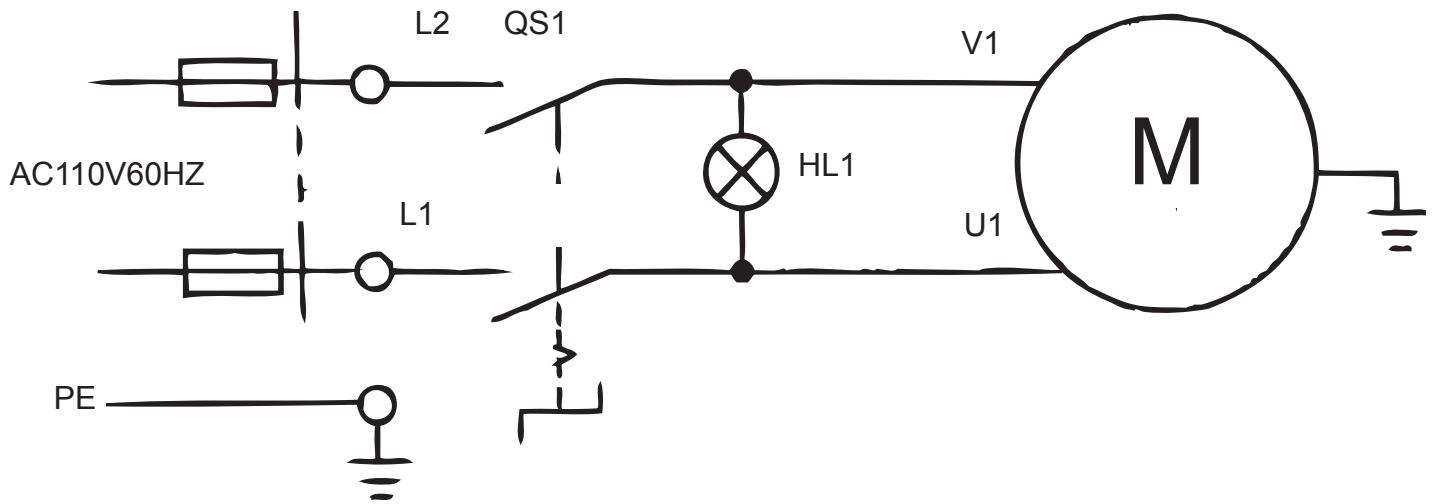

Model FP-CN-0008-B 16999

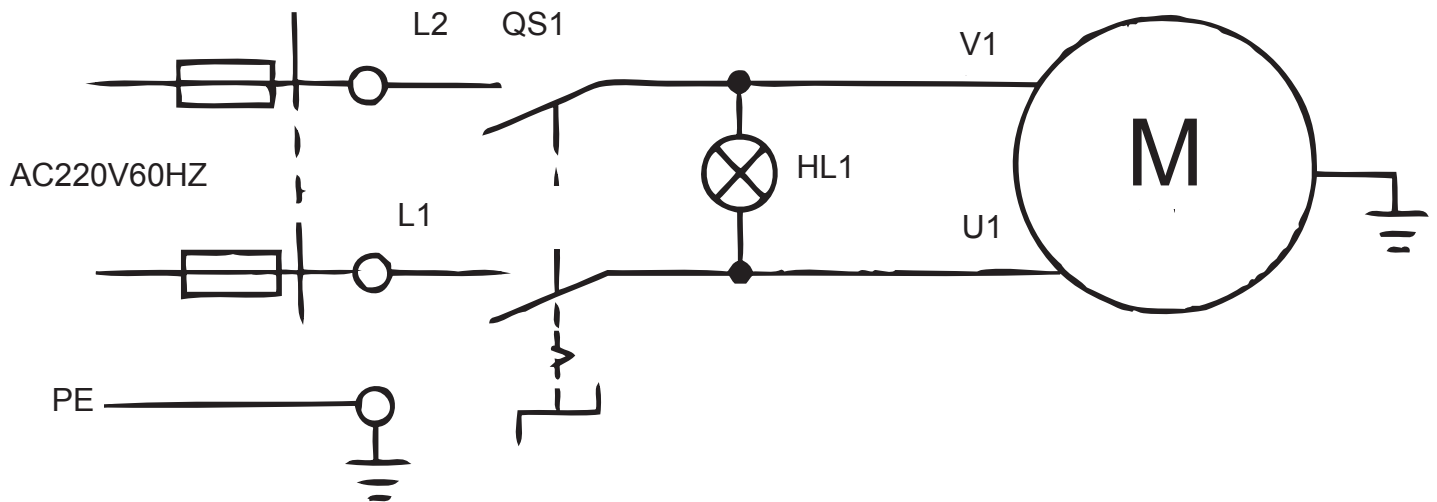



Warranty Registration

Thank you for purchasing an Omcan product. To register your warranty for this product, complete the information below, tear off the card at the perforation and then send to the address specified below. You can also register online by visiting:

Merci d'avoir acheté un produit Omcan. Pour enregistrer votre garantie pour ce produit, complétez les informations ci-dessous, détachez la carte au niveau de la perforation, puis l'envoyer à l'adresse spécifiée ci-dessous. Vous pouvez également vous inscrire en ligne en visitant:

Gracias por comprar un producto Omcan usted. Para registrar su garantía para este producto, complete la información a continuación, cortar la tarjeta en la perforación y luego enviarlo a la dirección indicada a continuación. También puede registrarse en línea en:

www.omcan.com/warrantyregistration.html

For mailing in Canada

Pour postale au Canada

Por correo en Canadá

OMCAN

PRODUCT WARRANTY REGISTRATION

3115 Pepper Mill Court,

Mississauga, Ontario

Canada, L5L 4X5

For mailing in the US

Pour diffusion aux États-Unis

Por correo en los EE.UU.

OMCAN

PRODUCT WARRANTY REGISTRATION

4450 Witmer Industrial Estates, Unit 4,

Niagara Falls, New York

USA, 14305

or email to: service@omcan.com



Purchaser's Information

Name: _____

Address: _____

City: _____ Province or State: _____ Postal or Zip: _____

Country: _____

Dealer from which Purchased: _____

Dealer City: _____ Dealer Province or State: _____

Invoice: _____

Model Name: _____ Model Number: _____

Machine Description: _____

Date of Purchase (MM/DD/YYYY): _____

Would you like to extend the warranty? Yes No

Company Name: _____

Telephone: _____

Email Address: _____

Type of Company:

Restaurant Bakery Deli

Butcher Supermarket Caterer

Institution (*specify*): _____

Other (*specify*): _____

Serial Number: _____

Date of Installation (MM/DD/YYYY): _____

Thank you for choosing Omcan | Merci d'avoir choisi Omcan | Gracias por elegir Omcan



Since 1951 Omcan has grown to become a leading distributor of equipment and supplies to the North American food service industry. Our success over these many years can be attributed to our commitment to strengthen and develop new and existing relationships with our valued customers and manufacturers. Today with partners in North America, Europe, Asia and South America, we continually work to improve and grow the company. We strive to offer customers exceptional value through our qualified local sales and service representatives who provide convenient access to over 3,500 globally sourced products.

Depuis 1951 Omcan a grandi pour devenir un des “leaders” de la distribution des équipements et matériel pour l’industrie des services alimentaires en Amérique du Nord. Notre succès au cours de ces nombreuses années peut être attribué à notre engagement à renforcer et à développer de nouvelles et existantes relations avec nos clients et les fabricants de valeur. Aujourd’hui avec des partenaires en Amérique du Nord, Europe, Asie et Amérique du Sud, nous travaillons continuellement à améliorer et développer l’entreprise. Nous nous efforçons d’offrir à nos clients une valeur exceptionnelle grâce à nos ventes locales qualifiées et des représentants de service qui offrent un accès facile à plus de 3500 produits provenant du monde entier.

Desde 1951 Omcan ha crecido hasta convertirse en un líder en la distribución de equipos y suministros de alimentos en América del Norte industria de servicios. Nuestro éxito en estos años se puede atribuir a nuestro compromiso de fortalecer y desarrollar nuevas relaciones existentes con nuestros valiosos clientes y fabricantes. Hoy con socios de América del Norte, Europa, Asia y América del Sur, que trabajan continuamente para mejorar y crecer la empresa. Nos esforzamos por ofrecer a nuestros clientes valor excepcional a través de nuestro local de ventas y representantes de los servicios que proporcionan un fácil acceso a más de 3,500 productos con origen a nivel mundial.

