



Bowl Cutters
Models FP-CN-0006, 0009
Items 23545, 23546
Instruction Manual



STOP
DO NOT RETURN
THIS PRODUCT TO THE STORE

For questions or assistance with this product call OMCAN Toll Free:
1 800 465 0234
Customer Service
or
visit the Support section of
www.omcan.com

Revised - 09/09/2019

Toll Free: 1-800-465-0234
Fax: 905-607-0234
Email: service@omcan.com
www.omcan.com

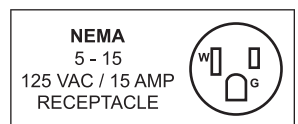

Table of Contents

Model FP-CN-0006 / Model FP-CN-0009

Section	Page
General Information -----	3 - 4
Safety and Warranty -----	4 - 5
Technical Specifications -----	5 - 6
Installation -----	6
Operation -----	6 - 7
Maintenance -----	7 - 8
Parts Breakdown -----	9 - 11
Electrical Schematics -----	12
Notes -----	13 - 14
Warranty Registration -----	15



General Information

Omcan Manufacturing and Distributing Company Inc., Food Machinery of America, Inc. dba Omcan and Omcan Inc. are not responsible for any harm or injury caused due to any person's improper or negligent use of this equipment. The product shall only be operated by someone over the age of 18, of sound mind, and not under the influence of any drugs or alcohol, who has been trained in the correct operation of this machine, and is wearing authorized, proper safety clothing. Any modification to the machine voids any warranty, and may cause harm to individuals using the machine or in the vicinity of the machine while in operation.

CHECK PACKAGE UPON ARRIVAL

Upon receipt of an Omcan shipment please inspect for external damage. If no damage is evident on the external packaging, open carton to ensure all ordered items are within the box, and there is no concealed damage to the machine. If the package has suffered rough handling, bumps or damage (visible or concealed), please note it on the bill of lading before accepting the delivery and contact Omcan within 24 hours, so we may initiate a claim with the carrier. A detailed report on the extent of the damage caused to the machine must be filled out within three days, from the delivery date shown in the shipping documents. Omcan has no recourse for damaged products that were shipped collect or third party.

Before operating any equipment, always read and familiarize yourself with all operation and safety instructions.

Omcan would like to thank you for purchasing this machine. It's of the utmost importance to save these instructions for future reference. Also save the original box and packaging for shipping the equipment if servicing or returning of the machine is required.

Omcan Fabrication et distribution Compañie Limité et Food Machinery d'Amérique, dba Omcan et Omcan Inc. ne sont pas responsables de tout dommage ou blessure causé du fait que toute personne ait utilisé cet équipement de façon irrégulière. Le produit ne doit être exploité que par quelqu'un de plus de 18 ans, saine d'esprit, et pas sous l'influence d'une drogue ou d'alcool, qui a été formé pour utiliser cette machine correctement, et est vêtu de vêtements de sécurité approprié. Toute modification de la machine annule toute garantie, et peut causer un préjudice à des personnes utilisant la machine ou des personnes à proximité de la machine pendant son fonctionnement.

VÉRIFIEZ LE COLIS DÈS RÉCEPTION

Dès réception d'une expédition d'Omcan veuillez inspecter pour dommages externes. Si aucun dommage n'est visible sur l'emballage externe, ouvrez le carton afin de s'assurer que tous les éléments commandés sont dans la boîte, et il n'y a aucun dommage dissimulé à la machine. Si le colis n'a subi aucune mauvaises manipulations, de bosses ou de dommages (visible ou cachée), notez-le sur le bond de livraison avant d'accepter la livraison et contactez Omcan dans les 24 heures qui suivent, pour que nous puissions engager une réclamation auprès du transporteur. Un rapport détaillé sur l'étendue des dommages causés à la machine doit être rempli dans un délai de trois jours, à compter de la date de livraison indiquée dans les documents d'expédition. Omcan n'a aucun droit de recours pour les produits endommagés qui ont été expédiés ou cueilli par un tiers transporteur.

General Information

Avant d'utiliser n'importe quel équipement, toujours lire et vous familiariser avec toutes les opérations et les consignes de sécurité.

Omcan voudrais vous remercier d'avoir choisi cette machine. Il est primordial de conserver ces instructions pour une référence ultérieure. Également conservez la boîte originale et l'emballage pour l'expédition de l'équipement si l'entretien ou le retour de la machine est nécessaire.

Omcan Empresa De Fabricacion Y Distribucion Inc. Y Maquinaria De Alimentos De America, Inc. dba Omcan y Omcan Inc. no son responsables de ningun daño o perjuicio causado por cualquier persona inadecuada o el uso descuidado de este equipo. El producto solo podra ser operado por una persona mayor de 18 años, en su sano juicio y no bajo alguna influencia de droga o alcohol, y que este ha sido entrenado en el correcto funcionamiento de esta máquina, y ésta usando ropa apropiada y autorizada. Cualquier modificación a la máquina anula la garantía y puede causar daños a las personas usando la máquina mientras esta en el funcionamiento.

REVISE EL PAQUETE A SU LLEGADA

Tras la recepcion de un envio Omcan favor inspeccionar daños externos. Si no hay daños evidentes en el empaque exterior, Habra el carton para asegurarse que todos los articulos solicitados estén dentro de la caja y no encuentre daños ocultos en la máquina. Si el paquete ha sufrido un manejo de poco cuidado, golpes o daños (visible o oculto) por favor anote en la factura antes de aceptar la entrega y contacte Omcan dentro de las 24 horas, de modo que podamos iniciar una reclamación con la compañía. Un informe detallado sobre los daños causados a la máquina debe ser llenado en el plazo de tres días, desde la fecha de entrega que se muestra en los documentos de envío. Omcan no tiene ningun recurso por productos dañados que se enviaron a recoger por terceros.

Antes de utilizar cualquier equipo, siempre lea y familiarizarse con todas las instrucciones de funcionamiento y seguridad.

Omcan le gustaría darle las gracias por la compra de esta máquina. Es de la mayor importancia para salvar estas instrucciones para futuras consultas. Además, guarda la caja original y el embalaje para el envío del equipo si servicio técnico o devolución de la máquina que se requiere.

Safety and Warranty

- This machine should only be operated by trained users. Before operating, users should know about the protection measures.
- Please turn off and unplug the machine before cleaning and maintenance.
- When you remove the protective measures in order to clean and maintain the machine, you should always proceed with caution.
- Damaged power cables may cause electric shock and should be replaced before any further operation.
- Please contact Omcan if you need to adjust or maintain the machine.
- These units are not designed for hummus

Safety and Warranty

- This machine must not be used to process bones, frozen meat or fish and non-food products.
- When the machine is in operation, do not put your hand into the bowl.

SAFETY DEVICES

- The cover plays an important role in protecting the user. The cover can only be moved away when the arm is unlocked.
- When the arm is unlocked or if the cover is not in place, the machine stops working.
- If the power cuts off unexpectedly, the machine must be restarted.
- Use the utmost care when using this machine.

NOTE: THESE BOWL CUTTERS ARE NOT IDEAL FOR MAKING LARGE BATCHES OF HUMMUS.

1 YEAR PARTS AND LABOUR WARRANTY

Within the warranty period, contact Omcan Inc. at 1-800-465-0234 to schedule an Omcan authorized service technician to repair the equipment locally.

Unauthorized maintenance will void the warranty. Warranty covers electrical and part failures, not improper use.

Please see <https://omcan.com/disclaimer> for complete info.

WARNING:

The packaging components (cardboard, polyethylene, and others) are classified as normal solid urban waste and can therefore be disposed of without difficulty.

In any case, for suitable recycling, we suggest disposing of the products separately (differentiated waste) according to the current norms.

DO NOT DISCARD ANY PACKAGING MATERIALS IN THE ENVIRONMENT!

Technical Specifications

FEATURES OF THE MACHINE

This machine is made with 304 stainless steel, it ensures that any components that touch food are clean. The knives are made with 4Cr13 stainless steel, which makes the knives more sharp and efficient. There is also a stainless steel bottom which can withstand heated product.

Technical Specifications

COMPONENTS

1. Container.
2. Cover.
3. Arm Lock.
4. Main Body.
5. Power Cable.
6. Feet.
7. Control Panel.
8. Knob for Controlling Speed.

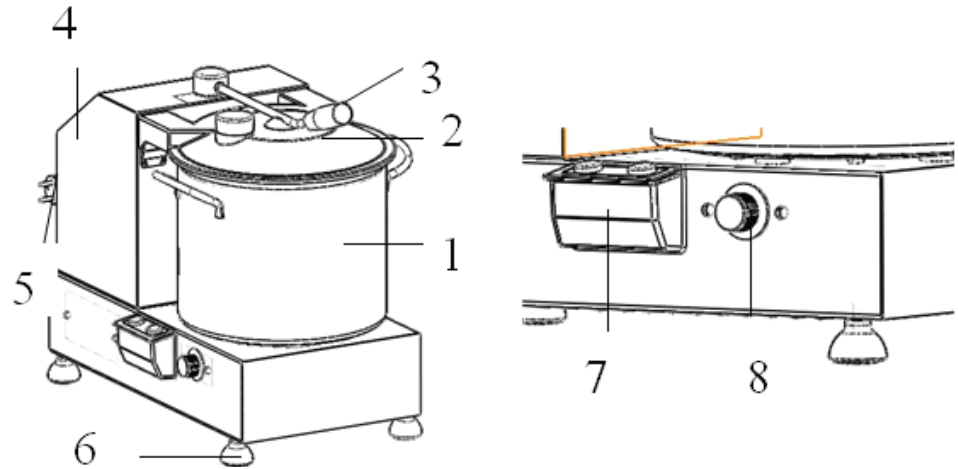

TECHNICAL DATA

Model	FP-CN-0006	FP-CN-0009
Power	1 HP / 0.75 kW	
Capacity	4 - 6 L / 4.2 - 6.4 QT	6 - 9 L / 6.4 - 9.5 QT
Electrical	110V / 60Hz / 1	
RPM	1100 - 2800	
Dimensions	15" x 11" x 15" / 381 x 279 x 381mm	18.5" x 11.4" x 17" / 470 x 290 x 432mm
Weight	42 lbs. / 19.1 kgs.	44 lbs. / 20 kgs.
Item Number	23545	23546

Installation

The machine should be placed on a dry, level table which must be large enough to support the machine. When it is installed, the room temperature should be set between +5°C and +35°C.

Operation

CONTROLLER

1. Set the rotating speed via the knob for controlling speed.
2. Start the machine by pressing the On/Off switch to "I".
3. Stop the machine by pressing the On/Off switch to "O"

Operation

FOOD FEEDING

Attention: Food is to be fed only when the machine is stopped. The knob for controlling speed must be set at the “o” position.

PROCEDURES

1. Turn the loading arm in the counterclockwise direction to remove the cover.
2. Pay attention to the two blades while feeding food into the container; Food should be cut into small blocks before feeding.

Warning: the food in the container is not allowed to exceed more than half of the total volume of the bowl.

3. In case of accidents, the user should pay attention on his own position when using the machine. The user’s body should be vertical with the working table. The user must not hold down the machine or attempt to prevent the machine from moving.

Do not get close to the machine and avoid touching the machine directly.

4. Put the cover in the start position, then rotate the loading arm until it locks.
5. Press the On/Off switch to “I”.
6. Do not mix on low speed at an extended period.
7. While the machine is in operation, extra food should be fed through the hole on the cover if needed.
8. Press the red stop button if the food cutting is finished. If the mixer is equipped with speed adjusting knob, then turn it to the “0” position and then stop the machine.

Maintenance

SHARPENING

Please sharpen the blades if the blades are not sharp enough to cut the food.

1. Turn off and unplug the machine.
2. Turn the loading arm to remove the cover.
3. Move the fixing axis of rotating blades away.
4. Use the sharpener from the manufacturer only. Sharpen the blade from the inside to outside along the blade edge.

CLEANING

- The machine should be cleaned at least once every day, more if necessary.
- The parts that touch the food directly or indirectly must be cleaned thoroughly.
- Water or high pressure spraying water cannot be used, as it will damage the machine. Brushes or other tools which may damage the surface also cannot be used.

The following procedures should be done before cleaning and maintenance:

- Turn off the power and unplug the unit.

Maintenance

- Turn the speed adjusting knob to the “0” position.

Clean the cover, rotating blades, axis and container

Rotate the loading arm, remove the cover, and the blade fixing axis and container can be lifted easily. Then use water and a neutral detergent to clean the above-mentioned parts.

Attention: Gloves should be worn for protection while operating and cleaning.

Attention: Machine must be switched off and unplugged.

Clean the machine body with a neutral detergent and damp cloth. Use a dry cloth to dry the machine after cleaning.

MAINTENANCE

BELT

The belt does not need to be adjusted.

FEET

As time goes on, the feet will deteriorate. You should change it to prevent accidents, please contact Omcan and request a replacement.

POWER CABLE

The power cable should be checked regularly. If it is damaged, please contact Omcan and request a replacement.

BLADES

Check whether the width of blades is less than 5cm. If it is, please contact Omcan and request a replacement.

LABEL

When the label is damaged, please contact Omcan and request a replacement.

REFERENCE

Item Number	Model Number	Description	Manufacturer Model Number
23545	FP-CN-0006	Bowl Cutter 6 L / 6 QT 1100-2800 RPM 1 HP / 750W 110V/60/1	HR-6
23546	FP-CN-0009	Bowl Cutter 9 L / 9 QT 1100-2800 RPM 1 HP / 750W 110V/60/1	HR-9

Parts Breakdown

Model FP-CN-0006 23545

Model FP-CN-0009 23546

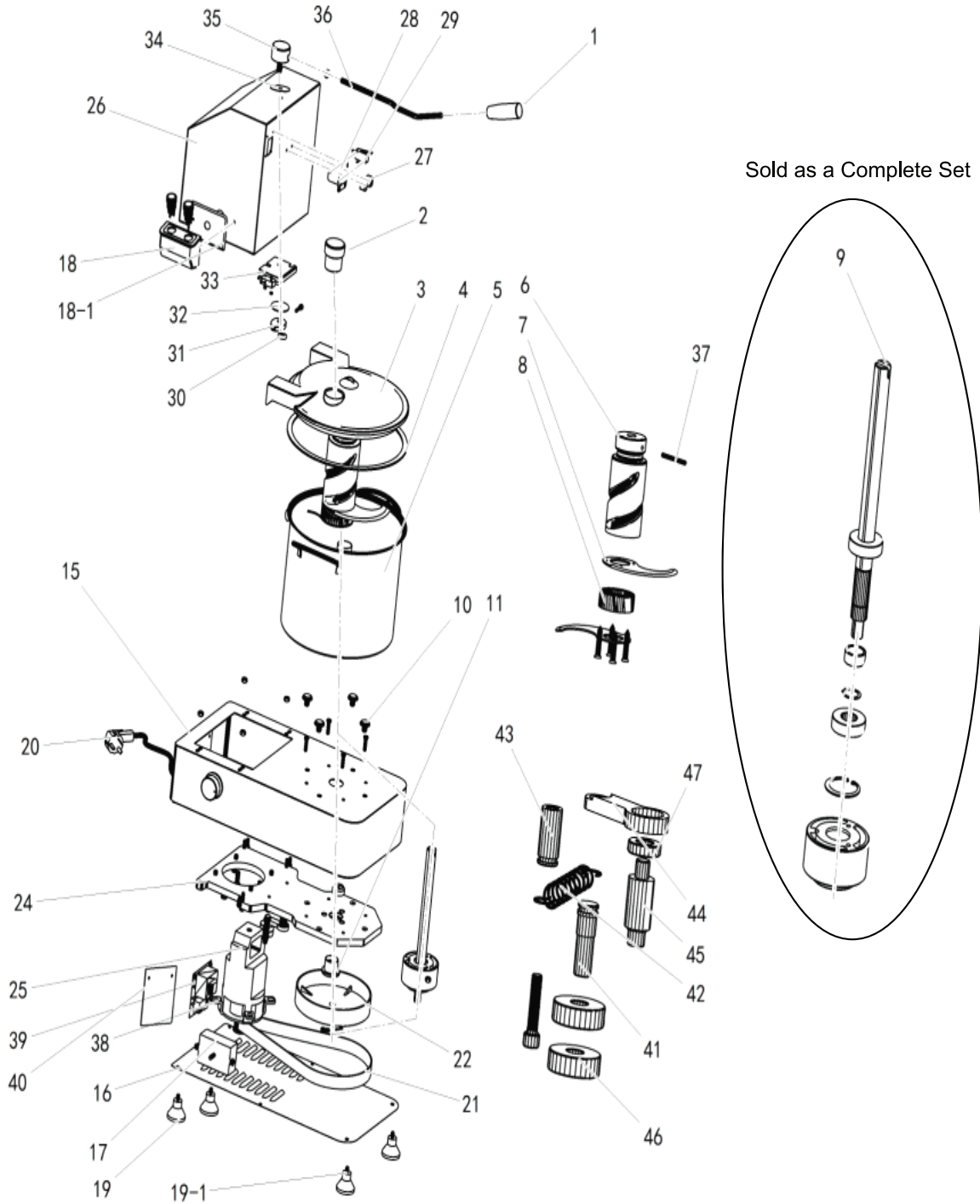

Parts Breakdown

Model FP-CN-0006 23545

Item No.	Description	Position	Item No.	Description	Position	Item No.	Description	Position
70288	Handle for HR-6	1	70306	Rubber Feet for HR-6	19	70323	Handle Seat for HR-6	35
70289	Chuck Plug for HR-6	2	70307	Power Cable for HR-6	20	70324	Compression Bar for HR-6	36
70290	PC Cover for HR-6	3	70308	Belt for HR-6	21	70325	Dowel for HR-6	37
70291	Water Proof Gasket for HR-6	4	70309	Big Belt Pulley for HR-6	22	70326	Motor Holder for HR-6	38
70292	Container for HR-6	5	70312	Main Board for HR-6	24	70327	Circuit Board for HR-6	39
70293	Up Tool Apron for HR-6	6	70313	Motor for HR-6	25	70328	Installation Board for HR-6	40
70294	Rotate Knives for HR-6	7	70314	Welding for HR-6	26	70329	Tension Wheel Shaft for HR-6	41
70295	Down Tool Apron for HR-6	8	70315	Limited Block for HR-6	27	70330	Tension Spring for HR-6	42
70297	Rubber Gasket for HR-6	10	70316	Front Switch Holder for HR-6	28	70331	Small Shaft for HR-6	43
71445	Locating Sleeve for HR-6	11	70317	Sure Model Switch for HR-6	29	70332	Tension Wheel Arm for HR-6	44
70301	Base Seat Component for HR-6	15	70318	Big Nut for HR-6	30	70333	Wheel Shaft 2 for HR-6	45
70302	Base Board for HR-6	16	70319	Cam for HR-6	31	70334	Bearing 6200 for HR-6	46
70303	Knob for HR-6	17	70320	Big Gasket for HR-6	32	70335	Bearing 6800 for HR-6	47
70304	Switch Box Seal Bar for HR-6	18	70321	Up Switch Holder for HR-6	33	70296	Complete Shaft Set for HR-6	
70305	Gasket for Electric Box for HR-6	18-1	70322	Nylon Gasket for HR-6	34			



Parts Breakdown

Model FP-CN-0009 23546

Item No.	Description	Position	Item No.	Description	Position	Item No.	Description	Position
70336	Handle for HR-9	1	70353	Gasket for Electric Box for HR-9	18-1	70370	Nylon Gasket for HR-9	34
70337	Chuck Plug for HR-9	2	70354	Rubber Feet for HR-9	19	70371	Handle Seat for HR-9	35
70338	PC Cover for HR-9	3	70355	Power Cable for HR-9	20	70372	Compression Bar for HR-9	36
70339	Water Proof Gasket for HR-9	4	70356	Belt for HR-9	21	70373	Dowel for HR-9	37
70340	Container for HR-9	5	70357	Big Belt Pulley for HR-9	22	70374	Motor Holder for HR-9	38
70341	Up Tool Apron for HR-9	6	70360	Main Board for HR-9	24	70375	Circuit Board for HR-9	39
70342	Rotate Knives for HR-9	7	70361	Motor for HR-9	25	70376	Installation Board for HR-9	40
70343	Down Tool Apron for HR-9	8	70362	Welding for HR-9	26	70377	Tension Wheel Shaft for HR-9	41
78688	Blade Shaft Complete for HR-9	9	70363	Limited for HR-9	27	70378	Tension Spring for HR-9	42
70345	Rubber Gasket for HR-9	10	70364	Front Switch Holder for HR-9	28	70379	Small Shaft for HR-9	43
41142	Locating Sleeve for HR-9	11	70365	Sure Model Switch for HR-9	29	70380	Tension Wheel Arm for HR-9	44
70349	Base Seat Component for HR-9	15	70366	Big Nut for HR-9	30	70381	Wheel Shaft 2 for HR-9	45
70350	Base Board for HR-9	16	70367	Cam for HR-9	31	70382	Bearing 6200 for HR-9	46
70351	Knob for HR-9	17	70368	Big Gasket for HR-9	32	70383	Bearing 6800 for HR-9	47
70352	Switch Box Seal Bar for HR-9	18	70369	Up Switch Holder for HR-9	33			

Electrical Schematics

Model FP-CN-0006 23545

Model FP-CN-0009 23546

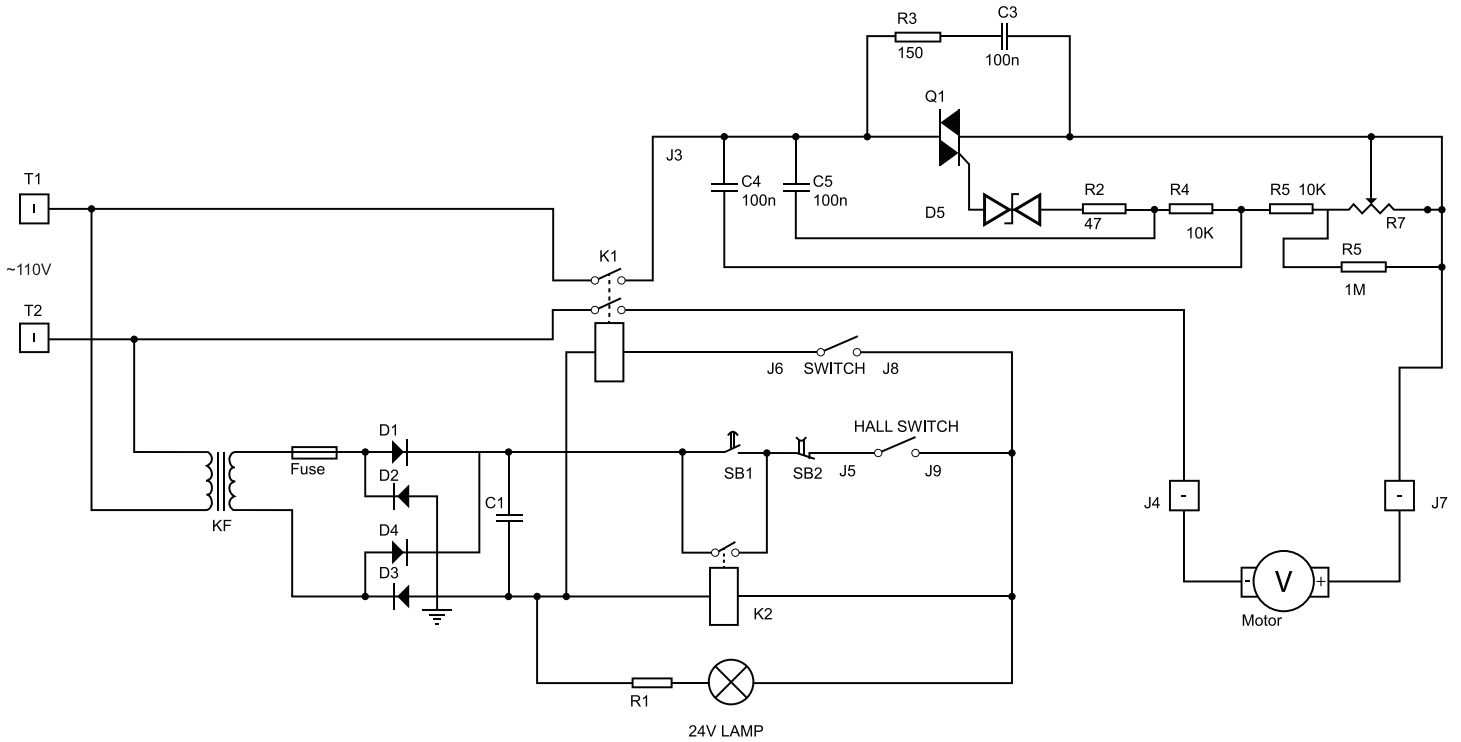



Warranty Registration

Thank you for purchasing an Omcan product. To register your warranty for this product, complete the information below, tear off the card at the perforation and then send to the address specified below. You can also register online by visiting:

Merci d'avoir acheté un produit Omcan. Pour enregistrer votre garantie pour ce produit, complétez les informations ci-dessous, détachez la carte au niveau de la perforation, puis l'envoyer à l'adresse spécifiée ci-dessous. Vous pouvez également vous inscrire en ligne en visitant:

Gracias por comprar un producto Omcan usted. Para registrar su garantía para este producto, complete la información a continuación, cortar la tarjeta en la perforación y luego enviarlo a la dirección indicada a continuación. También puede registrarse en línea en:

<https://omcan.com/warranty-registration/>

For mailing in Canada

Pour postale au Canada

Por correo en Canadá

OMCAN

PRODUCT WARRANTY REGISTRATION

3115 Pepper Mill Court,

Mississauga, Ontario

Canada, L5L 4X5

For mailing in the US

Pour diffusion aux États-Unis

Por correo en los EE.UU.

OMCAN

PRODUCT WARRANTY REGISTRATION

4450 Witmer Industrial Estates, Unit 4,

Niagara Falls, New York

USA, 14305

or email to: service@omcan.com



Purchaser's Information

Name: _____

Address: _____

City: _____ Province or State: _____ Postal or Zip: _____

Country: _____

Dealer from which Purchased: _____

Dealer City: _____ Dealer Province or State: _____

Invoice: _____

Model Name: _____ Model Number: _____

Machine Description: _____

Date of Purchase (MM/DD/YYYY): _____

Would you like to extend the warranty? Yes No

Company Name: _____

Telephone: _____

Email Address: _____

Type of Company:

Restaurant Bakery Deli

Butcher Supermarket Caterer

Institution (specify): _____

Other (specify): _____

Serial Number: _____

Date of Installation (MM/DD/YYYY): _____

Thank you for choosing Omcan | Merci d'avoir choisi Omcan | Gracias por elegir Omcan



Since 1951 Omcan has grown to become a leading distributor of equipment and supplies to the North American food service industry. Our success over these many years can be attributed to our commitment to strengthen and develop new and existing relationships with our valued customers and manufacturers. Today with partners in North America, Europe, Asia and South America, we continually work to improve and grow the company. We strive to offer customers exceptional value through our qualified local sales and service representatives who provide convenient access to over 5,000 globally sourced products.

Depuis 1951 Omcan a grandi pour devenir un des “leaders” de la distribution des équipements et matériel pour l’industrie des services alimentaires en Amérique du Nord. Notre succès au cours de ces nombreuses années peut être attribué à notre engagement à renforcer et à développer de nouvelles et existantes relations avec nos clients et les fabricants de valeur. Aujourd’hui avec des partenaires en Amérique du Nord, Europe, Asie et Amérique du Sud, nous travaillons continuellement à améliorer et développer l’entreprise. Nous nous efforçons d’offrir à nos clients une valeur exceptionnelle grâce à nos ventes locales qualifiées et des représentants de service qui offrent un accès facile à plus de 5000 produits provenant du monde entier.

Desde 1951 Omcan ha crecido hasta convertirse en un líder en la distribución de equipos y suministros de alimentos en América del Norte industria de servicios. Nuestro éxito en estos años se puede atribuir a nuestro compromiso de fortalecer y desarrollar nuevas relaciones existentes con nuestros valiosos clientes y fabricantes. Hoy con socios de América del Norte, Europa, Asia y América del Sur, que trabajan continuamente para mejorar y crecer la empresa. Nos esforzamos por ofrecer a nuestros clientes valor excepcional a través de nuestro local de ventas y representantes de los servicios que proporcionan un fácil acceso a más de 5,000 productos con origen a nivel mundial.

