



Bowl Cutter
Model FP-IT-0009
Item 10834
Instruction Manual



Revised - 09/12/2019

NSF *Locally QPS approved*

Toll Free: 1-800-465-0234
Fax: 905-607-0234
Email: service@omcan.com
www.omcan.com

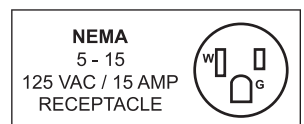

Table of Contents

Model FP-IT-0009

Section	Page
General Information -----	3 - 4
Safety and Warranty -----	4 - 6
Technical Specifications -----	6
Installation -----	6 - 7
Operation -----	7 - 8
Maintenance -----	8 - 9
Parts Breakdown -----	10 - 12
Electrical Schematics -----	13
Notes -----	14
Warranty Registration -----	15



General Information

Omcan Manufacturing and Distributing Company Inc., Food Machinery of America, Inc. dba Omcan and Omcan Inc. are not responsible for any harm or injury caused due to any person's improper or negligent use of this equipment. The product shall only be operated by someone over the age of 18, of sound mind, and not under the influence of any drugs or alcohol, who has been trained in the correct operation of this machine, and is wearing authorized, proper safety clothing. Any modification to the machine voids any warranty, and may cause harm to individuals using the machine or in the vicinity of the machine while in operation.

CHECK PACKAGE UPON ARRIVAL

Upon receipt of an Omcan shipment please inspect for external damage. If no damage is evident on the external packaging, open carton to ensure all ordered items are within the box, and there is no concealed damage to the machine. If the package has suffered rough handling, bumps or damage (visible or concealed), please note it on the bill of lading before accepting the delivery and contact Omcan within 24 hours, so we may initiate a claim with the carrier. A detailed report on the extent of the damage caused to the machine must be filled out within three days, from the delivery date shown in the shipping documents. Omcan has no recourse for damaged products that were shipped collect or third party.

Before operating any equipment, always read and familiarize yourself with all operation and safety instructions.

Omcan would like to thank you for purchasing this machine. It's of the utmost importance to save these instructions for future reference. Also save the original box and packaging for shipping the equipment if servicing or returning of the machine is required.

Omcan Fabrication et distribution Compañie Limité et Food Machinery d'Amérique, dba Omcan et Omcan Inc. ne sont pas responsables de tout dommage ou blessure causé du fait que toute personne ait utilisé cet équipement de façon irrégulière. Le produit ne doit être exploité que par quelqu'un de plus de 18 ans, saine d'esprit, et pas sous l'influence d'une drogue ou d'alcool, qui a été formé pour utiliser cette machine correctement, et est vêtu de vêtements de sécurité approprié. Toute modification de la machine annule toute garantie, et peut causer un préjudice à des personnes utilisant la machine ou des personnes à proximité de la machine pendant son fonctionnement.

VÉRIFIEZ LE COLIS DÈS RÉCEPTION

Dès réception d'une expédition d'Omcan veuillez inspecter pour dommages externes. Si aucun dommage n'est visible sur l'emballage externe, ouvrez le carton afin de s'assurer que tous les éléments commandés sont dans la boîte, et il n'y a aucun dommage dissimulé à la machine. Si le colis n'a subi aucune mauvaises manipulations, de bosses ou de dommages (visible ou cachée), notez-le sur le bond de livraison avant d'accepter la livraison et contactez Omcan dans les 24 heures qui suivent, pour que nous puissions engager une réclamation auprès du transporteur. Un rapport détaillé sur l'étendue des dommages causés à la machine doit être rempli dans un délai de trois jours, à compter de la date de livraison indiquée dans les documents d'expédition. Omcan n'a aucun droit de recours pour les produits endommagés qui ont été expédiés ou cueilli par un tiers transporteur.

General Information

Avant d'utiliser n'importe quel équipement, toujours lire et vous familiariser avec toutes les opérations et les consignes de sécurité.

Omcan voudrais vous remercier d'avoir choisi cette machine. Il est primordial de conserver ces instructions pour une référence ultérieure. Également conservez la boîte originale et l'emballage pour l'expédition de l'équipement si l'entretien ou le retour de la machine est nécessaire.

Omcan Empresa De Fabricacion Y Distribucion Inc. Y Maquinaria De Alimentos De America, Inc. dba Omcan y Omcan Inc. no son responsables de ningun daño o perjuicio causado por cualquier persona inadecuada o el uso descuidado de este equipo. El producto solo podra ser operado por una persona mayor de 18 años, en su sano juicio y no bajo alguna influencia de droga o alcohol, y que este ha sido entrenado en el correcto funcionamiento de esta máquina, y ésta usando ropa apropiada y autorizada. Cualquier modificación a la máquina anula la garantía y puede causar daños a las personas usando la máquina mientras esta en el funcionamiento.

REVISE EL PAQUETE A SU LLEGADA

Tras la recepcion de un envio Omcan favor inspeccionar daños externos. Si no hay daños evidentes en el empaque exterior, Habra el carton para asegurarse que todos los articulos solicitados estén dentro de la caja y no encuentre daños ocultos en la máquina. Si el paquete ha sufrido un manejo de poco cuidado, golpes o daños (visible o oculto) por favor anote en la factura antes de aceptar la entrega y contacte Omcan dentro de las 24 horas, de modo que podamos iniciar una reclamación con la compañía. Un informe detallado sobre los daños causados a la máquina debe ser llenado en el plazo de tres días, desde la fecha de entrega que se muestra en los documentos de envío. Omcan no tiene ningun recurso por productos dañados que se enviaron a recoger por terceros.

Antes de utilizar cualquier equipo, siempre lea y familiarizarse con todas las instrucciones de funcionamiento y seguridad.

Omcan le gustaría darle las gracias por la compra de esta máquina. Es de la mayor importancia para salvar estas instrucciones para futuras consultas. Además, guarda la caja original y el embalaje para el envío del equipo si servicio técnico o devolución de la máquina que se requiere.

Safety and Warranty

GENERAL PRECAUTIONS

- The CUTTER should be operated only by qualified people who should be informed about the safety measures described in this manual.
- In case of personnel turn-over, training is to be provided in advance.
- Before starting cleaning and maintenance, disconnect the machine's plug from the power supply socket.
- Assess the residual risks carefully when protection devices are removed to carry out cleaning and

Safety and Warranty

maintenance.

- Cleaning and maintenance require great concentration.
- A regular control of the electric supply cords is absolutely necessary; a worn-out or damaged cord can expose users to serious electric shock hazard.
- If the machine shows malfunctions, it is recommended not to use it and to abstain from trying to repair it; please call the "SERVICE CENTRE".
- Do not use the machine for products with bones, frozen foods, fishes or any product other than food.
- Do not introduce fingers in the opening or inside the machine when it is functioning.

THE MANUFACTURER IS NOT LIABLE IN THE FOLLOWING CASES:

- If the machine has been tampered by non-authorized personnel.
- If some parts have been substituted by non original spare parts.
- If the instructions contained in this manual are not followed accurately.
- If the machine surface is not cleaned with the right product.

SAFETY DEVICES INSTALLED ON THE MACHINE

MECHANICAL SAFETIES

The mechanical safety devices installed on the machine, described in this manual, comply with EC 2006/42.

- The safety protections are the cover, which can be removed only when the tank locking arm is up.

ELECTRICAL SAFETIES

The electrical safety devices installed on the machine, described in this manual, comply with EC 2006/95 and 2004/108.

The machine is equipped with:

- Micromechanic which stop the machine when the closing arm is lifted, and does not permit to start the machine if the cover is not closed.
- Relay which in case the power supply is missing; it is necessary to restart the machine.

Even though the professional CUTTER CE are provided with electrical and mechanical protections (when the machine is working and for maintenance and cleaning operations), there are still RESIDUAL RISKS that cannot be eliminated completely, these risks are mentioned in this manual under WARNING. These risks are cutting dangers caused by the knives during the loading of the product, or during the maintenance operations.

NOTE: THESE BOWL CUTTERS ARE NOT IDEAL FOR MAKING LARGE BATCHES OF HUMMUS.

1 YEAR PARTS AND LABOUR BENCH WARRANTY

Within the warranty period, contact Omcan Inc. at 1-800-465-0234 to schedule a drop off to either an Omcan authorized service depot in the area, or to an Omcan Service warehouse to repair the equipment.

Unauthorized maintenance will void the warranty. Warranty covers electrical and part failures, not improper use.

Safety and Warranty

Please see <https://omcan.com/disclaimer> for complete info.

WARNING:

The packaging components are classified as normal solid urban waste and can therefore be disposed of without difficulty.

In any case, for suitable recycling, we suggest disposing of the products separately (differentiated waste) according to the current norms.

DO NOT DISCARD ANY PACKAGING MATERIALS IN THE ENVIRONMENT!

Technical Specifications

Model	FP-IT-0009
Power	1 HP / 0.74 kW
Capacity	8.5 L / 9 QT
RPM	1700 - 2800
Electrical	110V / 60Hz / 1
Dimensions	17.9" x 14" x 15" / 455 x 355 x 380mm
Weight	50.7 lbs. / 23 kgs.
Item Number	10834

Installation

SETTING UP OF THE MACHINE

The machine must be installed on a working table suitable for its overall dimensions, therefore it must be adequately large, well levelled, dry, smooth, resistant, stable. Moreover the machine must be installed in a room with max. 75% not saline humidity at a temperature between +5°C and +35°C; that is to say in a place that does not provoke the machine failure.

ELECTRICAL CONNECTIONS

The appliance is equipped with a power supply cord which section 3x1.5mm², length 1.5m with a "NEMA" plug. Connect the appliance to 110 Volt 60 Hz, by interposing a differential magnetothermic switch of 10A, $\Delta I = 0.03A$. Check that the earthing is fully operational. Moreover check that the features on the rating plate - serial

Installation

number correspond to the features shown in the consignment and delivery note.

OPERATION CHECKS

Check the proper functioning of the machine according as follows:

1. Press the start button "I" and the stop button "0".
2. Check whether the machine stops after the lid has been removed.
3. In case of a CUTTER equipped with a speed dial knob, check whether the number of rotations increases by adjusting the knob clockwise.

Operation

CONTROLS

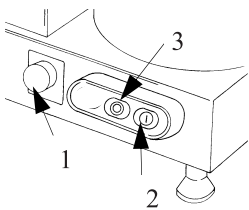

Controls are placed on the CUTTER body as shown in the picture.

NOTE: The speed dial knob (1) is installed only in the vv model.

1. Dial knob to set the number of rotations.
2. Start button "I".
3. Stop button "0".

LOADING OF THE PRODUCT

NOTE: Products to be cut must be loaded onto the basin when the motor is switched off and in case of a CUTTER vv after the speed dial knob has been set to the "0" position.

The procedure is as follows:

1. Rotate the arm counterclockwise in order to remove the lid.
2. Load the product into the basin and be careful of the two blades; if the product is in large pieces, break them into smaller pieces by hand before putting them onto the basin.
WARNING: Do not fill more than 1/2 of the tank.
3. To avoid accidents, position yourself safely: your body must be perpendicular to the working table; and your hands must not force on the machine or stop its movement.
Never lean on the machine and avoid any direct contact with it.
4. Re-position the lid and rotate the arm to closed position.
5. Start the machine by pushing the start button "I".
6. Don't use the machine at low speed for long time.
7. Load additional quantities of product through the upper hole during cutting, if necessary.
8. Once the product has been cut, stop the machine by pushing the red stop button. If the CUTTER is provided with a speed dial knob, adjust it to the "0" position and then stop the machine.
9. The cutter is equipped with a device that switches it off after 30 seconds, if the cutter has been used at minimum speed for more than 30 seconds. This device avoids motor overheating. If you use the cutter at low speed, rest it for at least 30 seconds.

Operation

SHARPENING OF ROTATING BLADES

WARNING: Follow the instructions below to sharpen the two blades if they do not cut properly:

1. Rotate the closing arm so as to remove the lid.
2. Remove the rotating blade holder.
3. Use the sharpening stone supplied with the machine and sharp knife on the cutting edge, from internal towards external until reviving the blade edge.

Maintenance

ORDINARY CLEANING

GENERAL FEATURES

- The CUTTER cleaning must be carried out at least once a day or more frequently, if necessary.
- Cleaning must be extremely accurate for those parts of the CUTTER which come into direct or indirect contact with foodstuffs.
- The CUTTER must not be cleaned with water-cleaners and high pressure jets of water. Tools, brushes and other devices likely to damage the CUTTER's surface must not be used.

Before carrying out any cleaning operation it is necessary:

- To disconnect the power supply plug from the socket to isolate the CUTTER from the rest of the electric circuit completely.
- To set the dial knob to the "0" position in case of a vv model.

CLEANING PROCEDURE OF THE MACHINE

CLEANING OF LID, ROTATING BLADE HOLDER AND BASIN

WARNING: Rotate the closing arm and lift the lid. Now the blade holder and the basin can be easily removed by pulling them upwards. Once they have been removed, clean them with water and neutral detergent.

NOTE: proceed with this operation wearing protection gloves.

ORDINARY CLEANING

NOTE: Disconnect the power supply plug.

Cleaning of the machine body on the worktable can be carried out with neutral detergent and a damp cloth frequently rinsed in water. When cleaning has been completed, dry the components accurately.

MAINTENANCE

GENERAL FEATURES

Before starting any maintenance activity it is necessary:

- To disconnect the power supply plug from the socket to isolate the CUTTER from the electric circuit completely.

Maintenance

- If the CUTTER is a vv model, to set the speed dial knob to the “0” position.

BELT

The belt does not need to be adjusted. Generally it must be replaced after 3/4 years; in this case, please call the “SERVICE CENTRE”.

FEET

Feet might deteriorate and lose elasticity; consequently the stability of the machine might be reduced. In this case they must be replaced.

POWER SUPPLY CORD

Periodically check whether the power supply cord is worn-out and, if this is the case, please call the “SERVICE CENTRE” to have it replaced.

BLADES

Check that blades have not lose more than 5 mm of thickness after sharpening. Call the “SERVICE CENTRE” to have them replaced.

KEYBOARD LABEL

The label of the keyboard could be marked and/or holed. In this case, please call the “SERVICE CENTRE” to have it replaced.

DISPOSAL OF THE MACHINE

PUTTING THE MACHINE OUT OF SERVICE

If for some reason, you decide to put the machine out of service, make sure nobody can use it: disconnect it from the mains and eliminate the electrical connections.

WEEE WASTE OF ELECTRIC AND ELECTRONIC EQUIPMENT

Directive 2002/95/EC, 2002/96/EC and 2003/108/EC on the restriction of the use of certain hazardous substances in electrical and electronic equipment, and waste electrical and electronic equipment. This symbol, crossed out wheelie bin, on the product or on its packaging indicates that this product must not be disposed of with your other household waste. Separate waste collection of this appliance is organized and managed by the manufacturer. It is the user’s responsibility to contact the manufacturer and follow the waste treatment system the manufacturer has adopted for separate waste collection. The separate collection and recycling of your waste equipment at the time of disposal will help to conserve natural resources and ensure that it is recycled in a manner that protects human health and the environment.

REFERENCE

Item Number	Model Number	Description	Manufacturer Model Number
10834	FP-IT-0009	Bowl Cutter 8.5 L / 9 QT 1700-2800 RPM 1 HP / 746 W 110V/60/1 cQPSus NSF	C9

Parts Breakdown

Model FP-IT-0009 10834

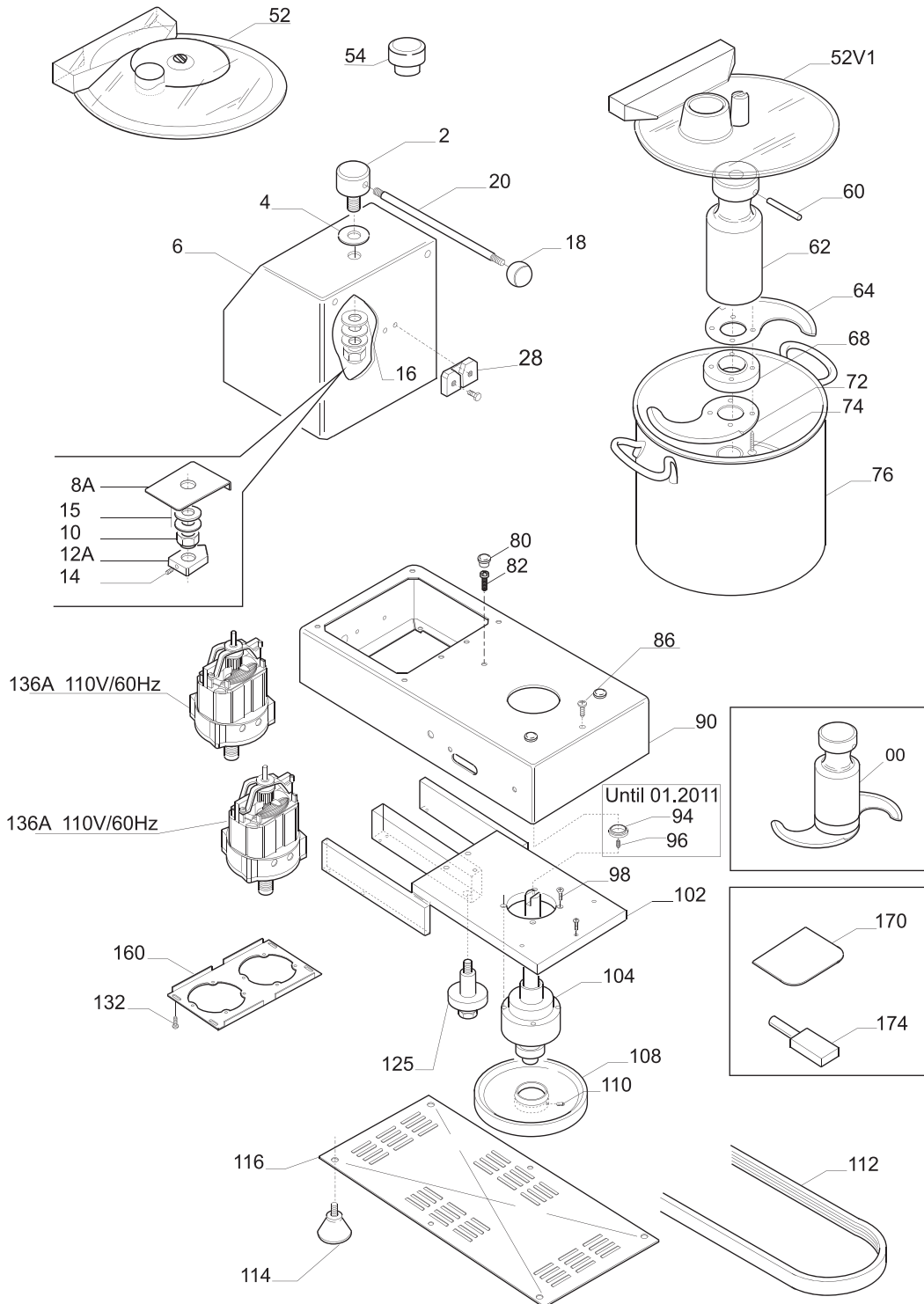

Parts Breakdown

Model FP-IT-0009 10834

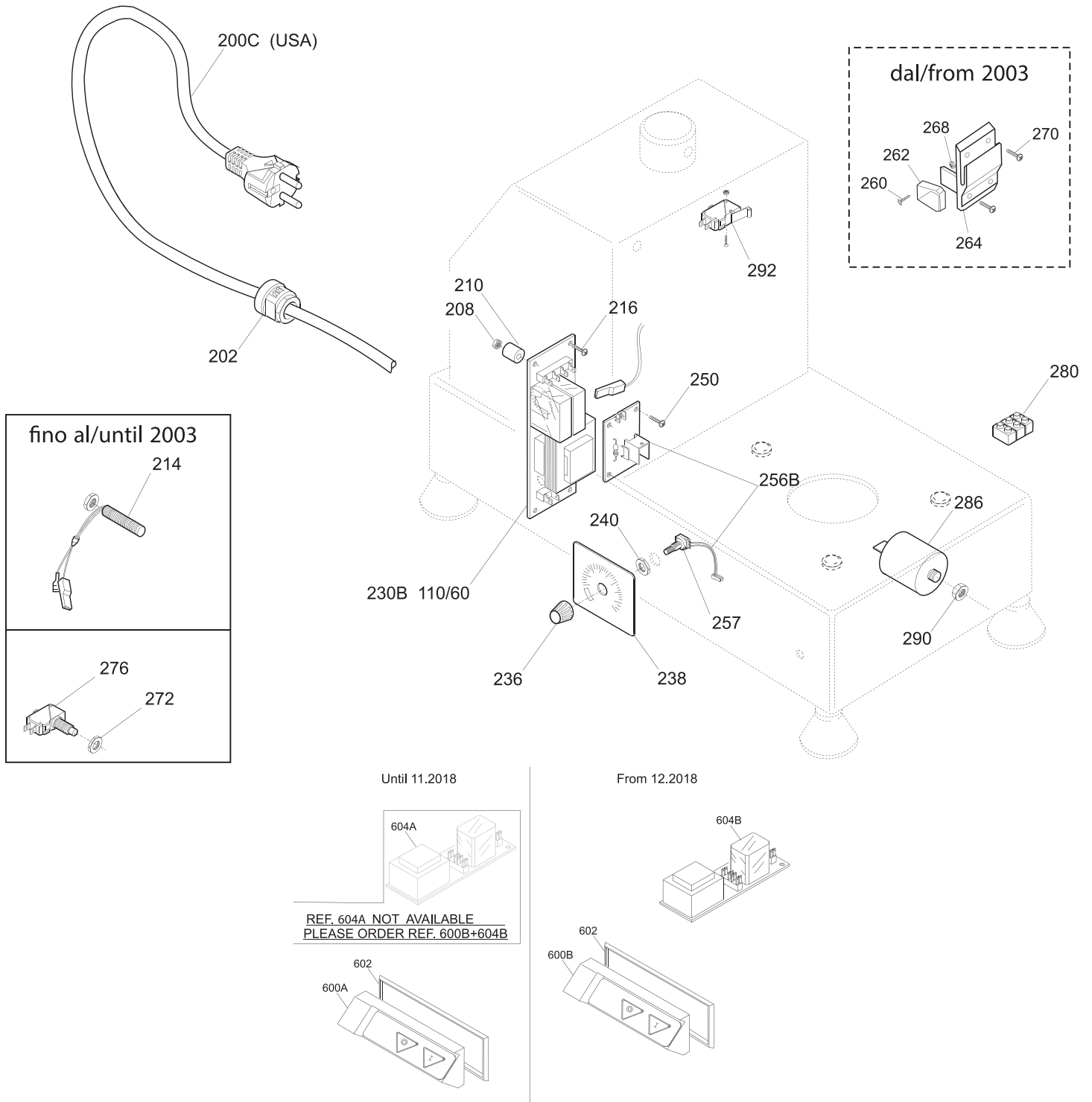

Parts Breakdown

Model FP-IT-0009 10834

Item No.	Description	Position	Item No.	Description	Position	Item No.	Description	Position
16995	Shaft with Regular Knives for C9	00	64403	Upper Knife for C9	64V	64406	Motor Support for C9	160
37186	Rod Holder Pin for C9	02	37210	Serrated Upper Knife for C9	64Z	60296	Bowl Scraper Red for C9	170
37187	Clutch Washer for C9	04	37195	Knife Spacer for C9	68	60297	Sharpening Stone for C9	174
37188	Frame Head for C9	06	64405	Knife Spacer for C9	68P	37339	Power Cord 110/60 USA for C9	200C
37150	Clutch Base for C9	08A	16464	Lower Knife for C9	72	37180	Strain Relief for C9	202
37151	Clutch Nut for C9	10	37211	Punched Bottom Knife for C9	72F	37202	Speed Control Knob for C9	236
37152	Microswitch Cam for C9	12A	37212	Lower Serrated Knife for C9	72Z	37203	Speed Control Label for C9	238
61573	Cup Spring 12.2x25x0.7 for C9	15	AC007	Screw Holder for C9	74	19360	110/60 Control Board + Variable Speed Drive for C9	256B
37189	Arm Knob for C9	18	26125	Bowl for C9	76	AB998	Screw TC + DIN 7985 M3x16 for C9	260
37190	Arm for C9	20	19350	Gum for C9 until 1999	80	19352	Mechanical Microswitch for C9	262
AC005	Steering Wheel Spacer for C9	27	AC004	Screw TC + DIN 7985 M5x12 for C9	82	19353	Microswitch Holder for C9	264
37191	Bowl Guide for C9	28	37196	Frame Body for C9	90	AB999	Nut ES, DIN 439 M3 Lower for C9	268
AC006	Screw TSP + DIN 965 M4x20 for C9	30	37197	Stainless Steel Plate for C9	102	AC000	Screw TSP + DIN 965 M3x8 for C9	270
18967	Lid with Gasket for C9 from OCT 03	52	17765	Aluminum Shaft for C9	104	37205	Mechanical Microswitch for C9	276+272
37192	Lid Plug for C9	54	37198	Pulley Assembly for C9	108	37176	Terminal Board for C9	280
37193	Blade Holder Pin for C9	60	AC008	Screw DIN 916 M8x10 NE for C9	110	37206	Filter for C9	286
37194	Blade Holder for C9	62	19359	Belt for C9	112	37178	Lever Microswitch for C9	292
64402	Door Knife for C9	62P	60294	Foot for C9	114	17197	Control Panel Assembly for C9	600A
16463	Upper Knife for C9	64	37199	Bottom Safety Grate for C9	116	AC009	Large Button Mounting Body Y18 for C9	600B
37209	Punched Upper Knife for C9	64F	37200	Small Pulley for C9	125	37207	Switch Gasket for C9	602
64404	Dough Upper Knife for C9	64P	16494	Motor 110/60 for C9	136A	AC010	Circuit Board 110/60 Y18 for C9	604B

Electrical Schematics

Model FP-IT-0009 10834

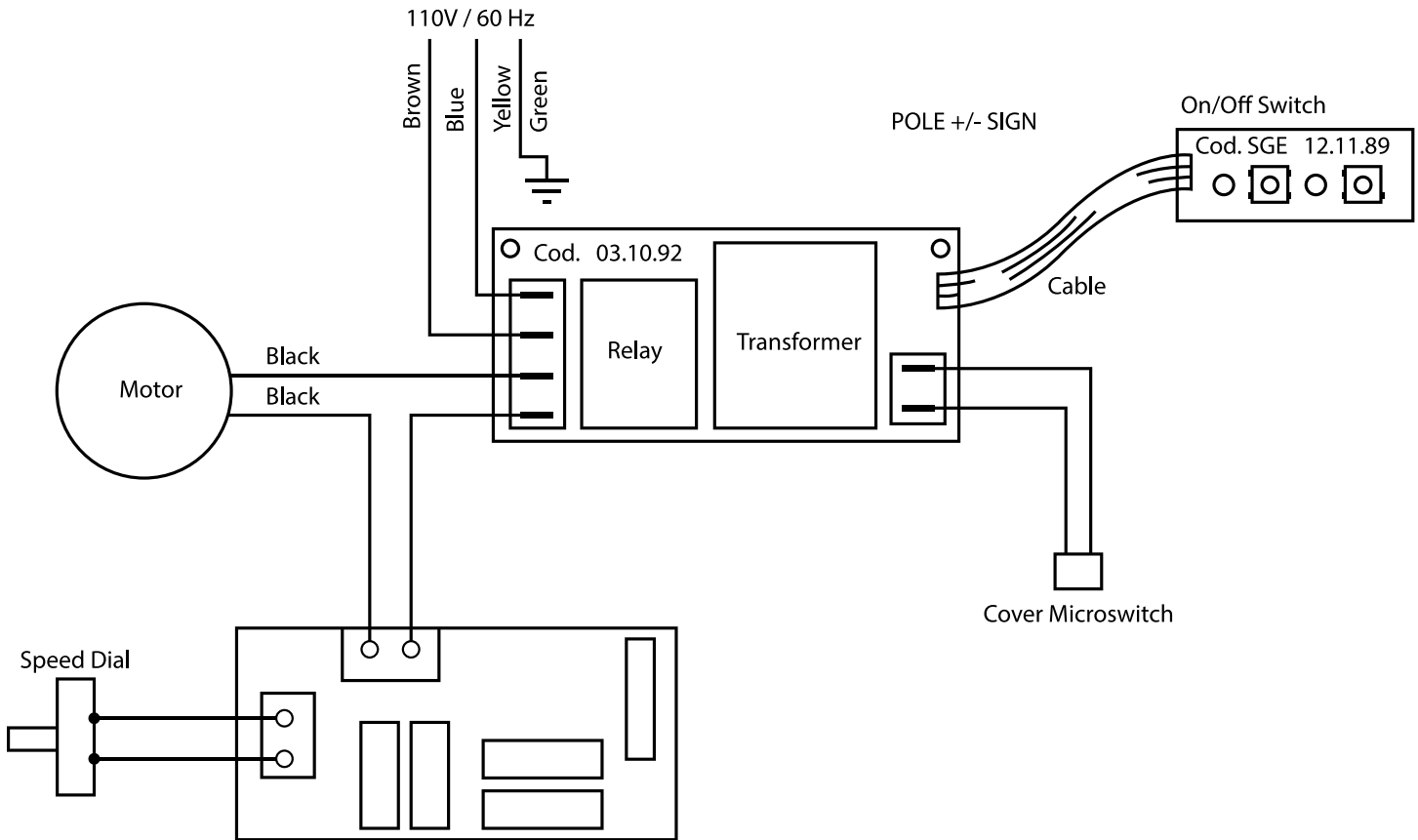



Warranty Registration

Thank you for purchasing an Omcan product. To register your warranty for this product, complete the information below, tear off the card at the perforation and then send to the address specified below. You can also register online by visiting:

Merci d'avoir acheté un produit Omcan. Pour enregistrer votre garantie pour ce produit, complétez les informations ci-dessous, détachez la carte au niveau de la perforation, puis l'envoyer à l'adresse spécifiée ci-dessous. Vous pouvez également vous inscrire en ligne en visitant:

Gracias por comprar un producto Omcan usted. Para registrar su garantía para este producto, complete la información a continuación, cortar la tarjeta en la perforación y luego enviarlo a la dirección indicada a continuación. También puede registrarse en línea en:

www.omcan.com/warrantyregistration.html

For mailing in Canada

Pour postale au Canada

Por correo en Canadá

For mailing in the US

Pour diffusion aux États-Unis

Por correo en los EE.UU.

OMCAN

PRODUCT WARRANTY REGISTRATION

3115 Pepper Mill Court,

Mississauga, Ontario

Canada, L5L 4X5

OMCAN

PRODUCT WARRANTY REGISTRATION

4450 Witmer Industrial Estates, Unit 4,

Niagara Falls, New York

USA, 14305

or email to: service@omcan.com



Purchaser's Information

Name: _____

Address: _____

City: _____ Province or State: _____ Postal or Zip: _____

Country: _____

Dealer from which Purchased: _____

Dealer City: _____ Dealer Province or State: _____

Invoice: _____

Model Name: _____ Model Number: _____

Machine Description: _____

Date of Purchase (MM/DD/YYYY): _____

Would you like to extend the warranty? Yes No

Company Name: _____

Telephone: _____

Email Address: _____

Type of Company:

Restaurant Bakery Deli

Butcher Supermarket Caterer

Institution (specify): _____

Other (specify): _____

Serial Number: _____

Date of Installation (MM/DD/YYYY): _____

Thank you for choosing Omcan | Merci d'avoir choisi Omcan | Gracias por elegir Omcan



Since 1951 Omcan has grown to become a leading distributor of equipment and supplies to the North American food service industry. Our success over these many years can be attributed to our commitment to strengthen and develop new and existing relationships with our valued customers and manufacturers. Today with partners in North America, Europe, Asia and South America, we continually work to improve and grow the company. We strive to offer customers exceptional value through our qualified local sales and service representatives who provide convenient access to over 3, 500 globally sourced products.

Depuis 1951 Omcan a grandi pour devenir un des “leaders” de la distribution des équipements et matériel pour l’industrie des services alimentaires en Amérique du Nord. Notre succès au cours de ces nombreuses années peut être attribué à notre engagement à renforcer et à développer de nouvelles et existantes relations avec nos clients et les fabricants de valeur. Aujourd’hui avec des partenaires en Amérique du Nord, Europe, Asie et Amérique du Sud, nous travaillons continuellement à améliorer et développer l’entreprise. Nous nous efforçons d’offrir à nos clients une valeur exceptionnelle grâce à nos ventes locales qualifiées et des représentants de service qui offrent un accès facile à plus de 3500 produits provenant du monde entier.

Desde 1951 Omcan ha crecido hasta convertirse en un líder en la distribución de equipos y suministros de alimentos en América del Norte industria de servicios. Nuestro éxito en estos años se puede atribuir a nuestro compromiso de fortalecer y desarrollar nuevas relaciones existentes con nuestros valiosos clientes y fabricantes. Hoy con socios de América del Norte, Europa, Asia y América del Sur, que trabajan continuamente para mejorar y crecer la empresa. Nos esforzamos por ofrecer a nuestros clientes valor excepcional a través de nuestro local de ventas y representantes de los servicios que proporcionan un fácil acceso a más de 3, 500 productos con origen a nivel mundial.

