



# Ice Cream Dipping Freezers

Models FR-CN-0160-S, 0360-S, 0460-S

Items 44590, 44588, 44589

## Instruction Manual



Revised - 11/14/2019

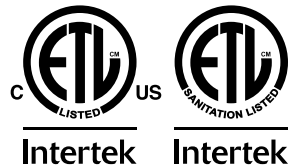

Toll Free: 1-800-465-0234  
Fax: 905-607-0234  
Email: [service@omcan.com](mailto:service@omcan.com)  
[www.omcan.com](http://www.omcan.com)

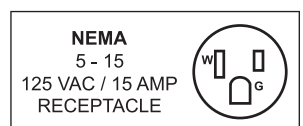

# ***Table of Contents***

Model FR-CN-0160-S / Model FR-CN-0360-S / Model FR-CN-0460-S

---

<b>Section</b>	<b>Page</b>
General Information -----	3 - 4
Safety and Warranty -----	4 - 6
Technical Specifications -----	6
Installation -----	6 - 7
Operation -----	7
Maintenance -----	7 - 8
Troubleshooting -----	8 - 9
Parts Breakdown -----	10 - 15
Electrical Schematics -----	16
Notes -----	17 - 18
Warranty Registration -----	19



# General Information

---

Omcan Manufacturing and Distributing Company Inc., Food Machinery of America, Inc. dba Omcan and Omcan Inc. are not responsible for any harm or injury caused due to any person's improper or negligent use of this equipment. The product shall only be operated by someone over the age of 18, of sound mind, and not under the influence of any drugs or alcohol, who has been trained in the correct operation of this machine, and is wearing authorized, proper safety clothing. Any modification to the machine voids any warranty, and may cause harm to individuals using the machine or in the vicinity of the machine while in operation.

## CHECK PACKAGE UPON ARRIVAL

Upon receipt of an Omcan shipment please inspect for external damage. If no damage is evident on the external packaging, open carton to ensure all ordered items are within the box, and there is no concealed damage to the machine. If the package has suffered rough handling, bumps or damage (visible or concealed), please note it on the bill of lading before accepting the delivery and contact Omcan within 24 hours, so we may initiate a claim with the carrier. A detailed report on the extent of the damage caused to the machine must be filled out within three days, from the delivery date shown in the shipping documents. Omcan has no recourse for damaged products that were shipped collect or third party.

**Before operating any equipment, always read and familiarize yourself with all operation and safety instructions.**

Omcan would like to thank you for purchasing this machine. It's of the utmost importance to save these instructions for future reference. Also save the original box and packaging for shipping the equipment if servicing or returning of the machine is required.

---

Omcan Fabrication et distribution Compañie Limité et Food Machinery d'Amérique, dba Omcan et Omcan Inc. ne sont pas responsables de tout dommage ou blessure causé du fait que toute personne ait utilisé cet équipement de façon irrégulière. Le produit ne doit être exploité que par quelqu'un de plus de 18 ans, saine d'esprit, et pas sous l'influence d'une drogue ou d'alcool, qui a été formé pour utiliser cette machine correctement, et est vêtu de vêtements de sécurité approprié. Toute modification de la machine annule toute garantie, et peut causer un préjudice à des personnes utilisant la machine ou des personnes à proximité de la machine pendant son fonctionnement.

## VÉRIFIEZ LE COLIS DÈS RÉCEPTION

Dès réception d'une expédition d'Omcan veuillez inspecter pour dommages externes. Si aucun dommage n'est visible sur l'emballage externe, ouvrez le carton afin de s'assurer que tous les éléments commandés sont dans la boîte, et il n'y a aucun dommage dissimulé à la machine. Si le colis n'a subi aucune mauvaises manipulations, de bosses ou de dommages (visible ou cachée), notez-le sur le bond de livraison avant d'accepter la livraison et contactez Omcan dans les 24 heures qui suivent, pour que nous puissions engager une réclamation auprès du transporteur. Un rapport détaillé sur l'étendue des dommages causés à la machine doit être rempli dans un délai de trois jours, à compter de la date de livraison indiquée dans les documents d'expédition. Omcan n'a aucun droit de recours pour les produits endommagés qui ont été expédiés ou cueilli par un tiers transporteur.

# General Information

---

Avant d'utiliser n'importe quel équipement, toujours lire et vous familiariser avec toutes les opérations et les consignes de sécurité.

Omcan voudrais vous remercier d'avoir choisi cette machine. Il est primordial de conserver ces instructions pour une référence ultérieure. Également conservez la boîte originale et l'emballage pour l'expédition de l'équipement si l'entretien ou le retour de la machine est nécessaire.

---

Omcan Empresa De Fabricacion Y Distribucion Inc. Y Maquinaria De Alimentos De America, Inc. dba Omcan y Omcan Inc. no son responsables de ningun daño o perjuicio causado por cualquier persona inadecuada o el uso descuidado de este equipo. El producto solo podra ser operado por una persona mayor de 18 años, en su sano juicio y no bajo alguna influencia de droga o alcohol, y que este ha sido entrenado en el correcto funcionamiento de esta máquina, y ésta usando ropa apropiada y autorizada. Cualquier modificación a la máquina anula la garantía y puede causar daños a las personas usando la máquina mientras esta en el funcionamiento.

## REVISE EL PAQUETE A SU LLEGADA

Tras la recepcion de un envio Omcan favor inspeccionar daños externos. Si no hay daños evidentes en el empaque exterior, Habra el carton para asegurarse que todos los articulos solicitados estén dentro de la caja y no encuentre daños ocultos en la máquina. Si el paquete ha sufrido un manejo de poco cuidado, golpes o daños (visible o oculto) por favor anote en la factura antes de aceptar la entrega y contacte Omcan dentro de las 24 horas, de modo que podamos iniciar una reclamación con la compañía. Un informe detallado sobre los daños causados a la máquina debe ser llenado en el plazo de tres días, desde la fecha de entrega que se muestra en los documentos de envío. Omcan no tiene ningun recurso por productos dañados que se enviaron a recoger por terceros.

Antes de utilizar cualquier equipo, siempre lea y familiarizarse con todas las instrucciones de funcionamiento y seguridad.

Omcan le gustaría darle las gracias por la compra de esta máquina. Es de la mayor importancia para salvar estas instrucciones para futuras consultas. Además, guarda la caja original y el embalaje para el envío del equipo si servicio técnico o devolución de la máquina que se requiere.

# Safety and Warranty

---

## CAUTION FOR USING

1. Unpack all packages before using the showcase. Don't bend it over more than 60° while moving it.
2. The showcase should be installed in the environment of good ventilation, Cool and dry and without corrosive gas. It should not be installed close to heat sources or directly under the sunlight. The space more than 10cm between the wall of the front and the back of the showcase should be allowed. When installing, the universal wheels should be padded well. So as to make the showcase be level and stable, or

# Safety and Warranty

---

it will cause vibration and too much noise.

3. When initial operation, the refrigerator should run empty for about one hour before storing food in it.
4. Before placing food into the freezer, adjust the temperature control to the lowest point (highest number) and let it run until the temperature of inner cabinet decreases to 0°F. Put the food in, and after 12 hours adjust the temperature control to the normal point.
5. The thermostat could adjust the temperature inside the showcase. When you turn the knob in clockwise. The bigger the figure, the lower the temperature. Generally, the position of '4' is suitable. '0' position stand for stopping operation. 'Max' position will be operating not continually as compressor won't stop (no cycle). Turn the temperature control to the "4" or "5" when temperature inside is stable for ice cream and similar products.
6. Never store flammable, explosive or corrosive products in the freezer, and keep the freezer away from such materials.
7. If power is cut off, wait at least 5 minutes before turning on again to avoid damage to the compressor.
8. To save energy, the door should not be frequently opened for left open for a long time.
9. The surface and the inside of the showcase should be dry and clean. Long term moisture with cause the showcase rust slowly. (There will be some stains on the surface.)
10. Periodical cleaning is suggested for your reference. Generally, 30-45 days once is best. When cleaning, it is best to wipe the inside and the surface of the showcase with the soft cloth with neutral soap or detergent.

**Attention: To ensure safety, the power plug must be pulled out before cleaning. All safety precautions must be followed. Dispose of properly in accordance with Federal or local regulations. Risk of fire or explosion due to puncture of refrigerant tubing. Follow handling instructions carefully.**

**DANGER: Risk of fire or explosion. Flammable refrigerant R290 used. To be repaired only by trained service personnel. Do not use mechanical devices to defrost refrigerator. Do not puncture refrigerant tubing.**

## 1 YEAR PARTS AND LABOUR WARRANTY

Within the warranty period, contact Omcan Inc. at 1-800-465-0234 to schedule an Omcan authorized service technician to repair the equipment locally.

Unauthorized maintenance will void the warranty. Warranty covers electrical and part failures, not improper use.

Please see <https://omcan.com/disclaimer> for complete info.

### WARNING:

The packaging components are classified as normal solid urban waste and can therefore be disposed of without difficulty.

In any case, for suitable recycling, we suggest disposing of the products separately (differentiated waste) according to the current norms.

# Safety and Warranty

DO NOT DISCARD ANY PACKAGING MATERIALS IN THE ENVIRONMENT!

# Technical Specifications

Model	FR-CN-0160-S	FR-CN-0360-S	FR-CN-0460-S
Climate Type	N/ST		
Freezer Capacity	120 L / 4.2 cu.ft.	290 L / 10.2 cu.ft.	370 L / 13.1 cu.ft.
Temperature Range	≤-26°C / (-15°F)		
Refrigerant	R290		
Compressor HP	1/4+	2/5+	1/2+
Amps	3	4	
Tub Load Quantity	4 displayed + 2 stored	8 displayed + 6 stored	10 displayed + 8 stored
Weight	154.3 lbs. / 70 kgs.	242.5 lbs. / 110 kgs.	280 lbs. / 127 kgs.
Dimensions	26.2" x 28.1" x 34.4" 665 x 715 x 875mm	49.6" x 28.1" x 34.4" 1260 x 715 x 875mm	60.2" x 28.1" x 34.4" 1530 x 715 x 875mm
Item Number	44590	44588	44589

# Installation

## GLASS CANOPY ASSEMBLY

### INCLUDED HARDWARE

- 1 - Front Rail.
- 2 - Side Rails.
- 4 - Metal Plate for Side Rails.
- 8 - L-Shaped Brackets.
- 11 - Screws and Metal Washers for Rails.
- 20 - Fasteners for Glass Panels.

**Note: If the fasteners are loose after assembling, you may fasten it with the white washer.**

1. Install the 3 plastic channels along the sides and front of the cabinet using the Phillips screws and metal washers. A short channel should be installed on each side, and the long channel should be installed on the front.
2. Insert the side glass panel into the side channel. Attach a metal plate to the cabinet at both ends of the channel, using the Phillips screws and metal washers. Then, attach each of the metal plates to the side glass panel using the socket head screws, metal washers, and associated metal fasteners. Repeat this step on the other side of the cabinet.

# Installation

---

3. Insert the front glass panel into the front channel. Then, use the L-shaped brackets and the fasteners to attach the front glass panel to each of the side panels. There are two bracket mounting locations on each side; one at the top, and one at the bottom.
4. Install the gasket on the top edge of the front glass panel, and place top glass panel atop the front and side panels.
5. Use the style of L-shaped brackets and fasteners referenced in Step 3 to attach the top glass panel to each of the side glass panels. There are two bracket mounting locations on each side; one at the front, and one at the back.

# Operation

---

## FOOD STORAGE

- Do not fill the freezer full of products. You should leave space between items and the inner surface of the cabinet, so as to keep good ventilation of cold air and freeze evenly. Do not put in any bottled or canned beverage with freezing point above the temperature in the cabinet when it is below zero.
- For foods that should be moisture-free or lose water easily, wrap them up with hermetical food bags or fresh films before putting in the cabinet for the sake of avoiding smell-mixing and reducing frosting.
- Storage of volatile and combustible gases, liquids such as strong alkalies, strong acids, petrol ,etc. is forbidden.
- Never put hot food directly in the freezer. Food should be cold or frozen before placing it inside.
- The cabinet is intended exclusively for the storage and/or display of packaged foods only.

# Maintenance

---

- The freezer should be cleaned regularly. When cleaning, turn off the power, take out the food in the cabinet, clean the inside using water or a little neutral detergent.
- Do not use boiling water, acid, chemical diluents, petrol and oil, or dirt-removing powder.
- Dry it after cleaning.
- Use light soap water when cleaning the door seal, apply a little of talcum powder on it after natural drying to extend its service life.
- Use soft cloth with water or a little detergent to clean the out surface. Note, keeping the power supply and lower part of connect wires away from water to avoid electricity leakage.
- Except common breakdowns, those who are not service technician should not take apart and repair the freezer on their own so as to avoid worsening the trouble. Unauthorized repair of electrical part such as compressor, temperature controller is forbidden.

## DEFROSTING

- Defrost for better freezing efficiency when the frost film in the cabinet is 4-5mm thick.
- When defrosting, turn off the power, take out the frozen foods, open the door for warming and melting. Use a soft cloth to absorb water and clean it up.

# Maintenance

- Do not use sharp metal tools such as steel brush to clean the frost film when defrosting so as to avoid evaporator damage.

# Troubleshooting

Problem	Possible Cause	Solution
The indicator is not on. The compressor does not start.	The plug isn't fully connected to the socket.	Replug it.
	No power.	Connect the socket with power.
The indicator is on, but the compressor doesn't work and buzzes only.	The power voltage is <98V.	Put a power-regulator more than 1000W power together.
The compressor stops a minute after start, and restart after a few minutes, and so repeatedly.	The power voltage is >132V.	Put a power-regulator more than 1000W power together.
The compressor works normally, but the temperature in the cabinet lowers too slowly.	The door is opened too frequently.	Reduce open times.
	The food in the cabinet is too much, or placed improperly.	Place foods properly, keep space between them for ventilation of cold air.
	The frost film is too thick.	Take out foods and defrost.
	The surface of the condenser is too dirty.	Stop and clean the condenser.
	The door seals badly.	Adjust the door seal.
The noise is too loud.	The freezer is placed unstably.	Place it stably.
	The fixing of the freezer is loose.	Tighten the fixing.
	There's contact between pipes.	Separate them.

### THE FOLLOWING ARE NOT FAULTS:

- When the freezer is working or after stopping for a while, the refrigerant in the pipes is cycling and gives out "running water" sounds.
- The surface temperature of the compressor may be up 70~80°C when it is working.
- The back side of step freezer gives out heat.
- In rainy season, the outer surface of the cabinet may have dew, which makes no defects on normal use. Just dry it with a piece of cloth.

# Troubleshooting

## REFERENCE

Item Number	Model Number	Description	Manufacturer Model Number
44590	FR-CN-0160-S	Flat Sneeze Guard Ice Cream Dipping Freezer 26" 110V/60/1 cETLus/ETL Sanitation	RI-160DC
44588	FR-CN-0360-S	Flat Sneeze Guard Ice Cream Dipping Freezer 49" 110V/60/1 cETLus/ETL Sanitation	RI-360DC
44589	FR-CN-0460-S	Flat Sneeze Guard Ice Cream Dipping Freezer 60" 110V/60/1 cETLus/ETL Sanitation	RI-460DC

# Parts Breakdown

Model FR-CN-0160-S 44590

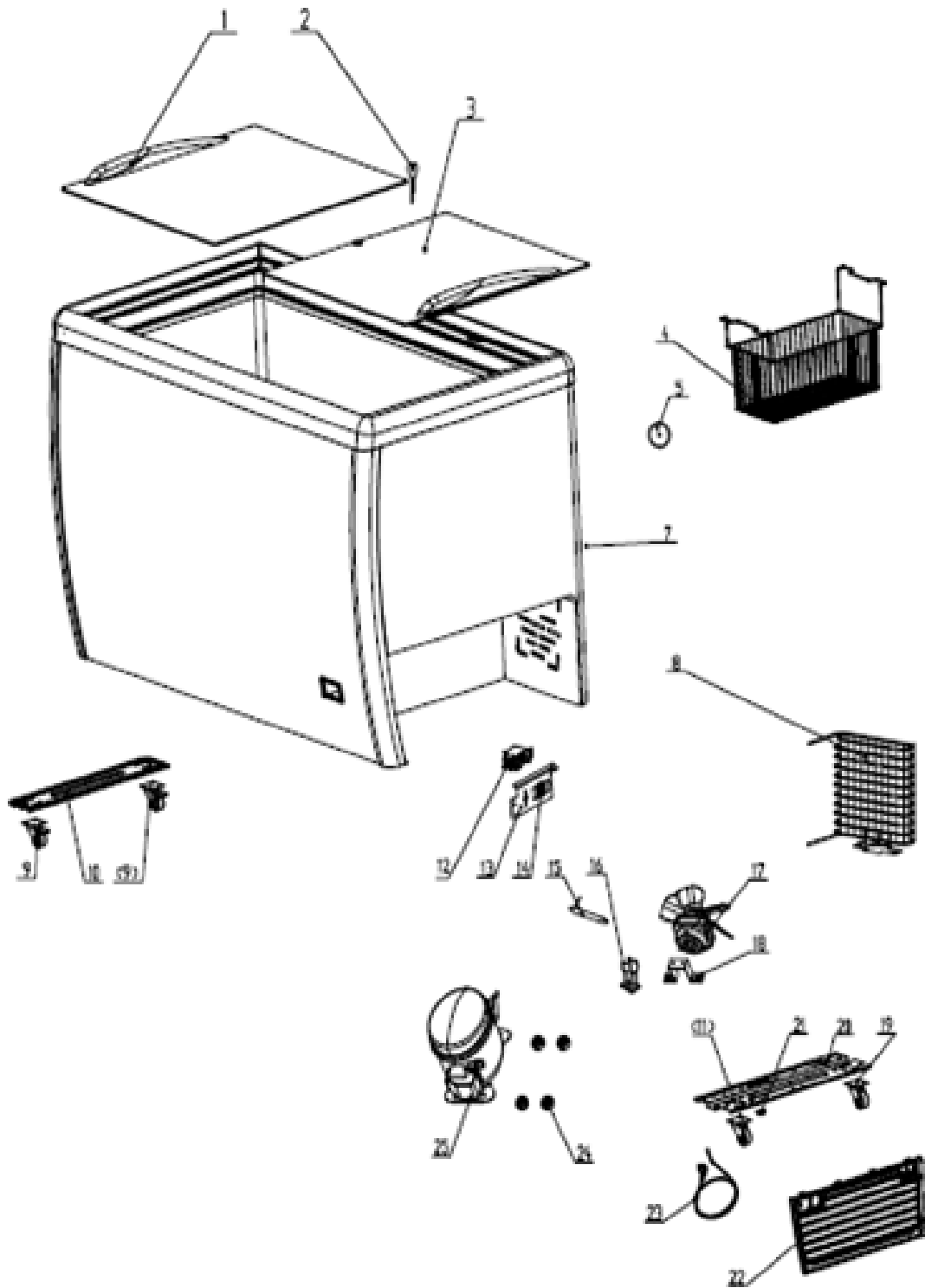

# Parts Breakdown

## Model FR-CN-0160-S 44590

Item No.	Description	Position	Item No.	Description	Position	Item No.	Description	Position
69421	Upper Glass Door for RI-160DC	1	28445	Caster with Lock for RI-160DC	9	64768	Fan Motor Support for RI-160DC	18
41162	Key/Lock for RI-160DC	2	28449	Thermostat for RI-160DC	12	28446	Castor without Lock for RI-160DC	19
69422	Lower Glass Door for RI-160DC	3	64766	Thermostat Support for RI-160DC	13	78720	Compressor Support for RI-160DC	20
31440	Basket for RI-160DC	4	39587	Indicator Lamp for RI-160DC	14	28447	Shutter for RI-160DC	22
64763	Thermostat Cover for RI-160DC	5	39586	Filter for RI-160DC	15	28448	Plug for RI-160DC	23
64769	Cabinet Plastic Frame for RI-160DC	7	64441	Filter Support for RI-160DC	16	63504	Compressor (R290) for RI-160DC	24, 25
28453	Condenser for RI-160DC	8	64767	Fan Motor for RI-160DC	17			

## Glass Sneeze Guard

Item No.	Description	Position	Item No.	Description	Position	Item No.	Description	Position
AC116	Front Rail for RI-160DC		AC120	Screws and Metal Washers for Rails for RI-160DC		AC124	Front Glass for RI-160DC	
AC117	Side Rail for RI-160DC		AC121	Fasteners for Glass Panels for RI-160DC		AC125	Top Glass for RI-160DC	
AC118	Metal Plate for Side Rails for RI-160DC		AC122	Gasket of Glass for RI-160DC				
AC119	L-Shaped Bracket for RI-160DC		AC123	SIDE GLASS FOR RI-160DC				

# Parts Breakdown

Model FR-CN-0360-S 44588

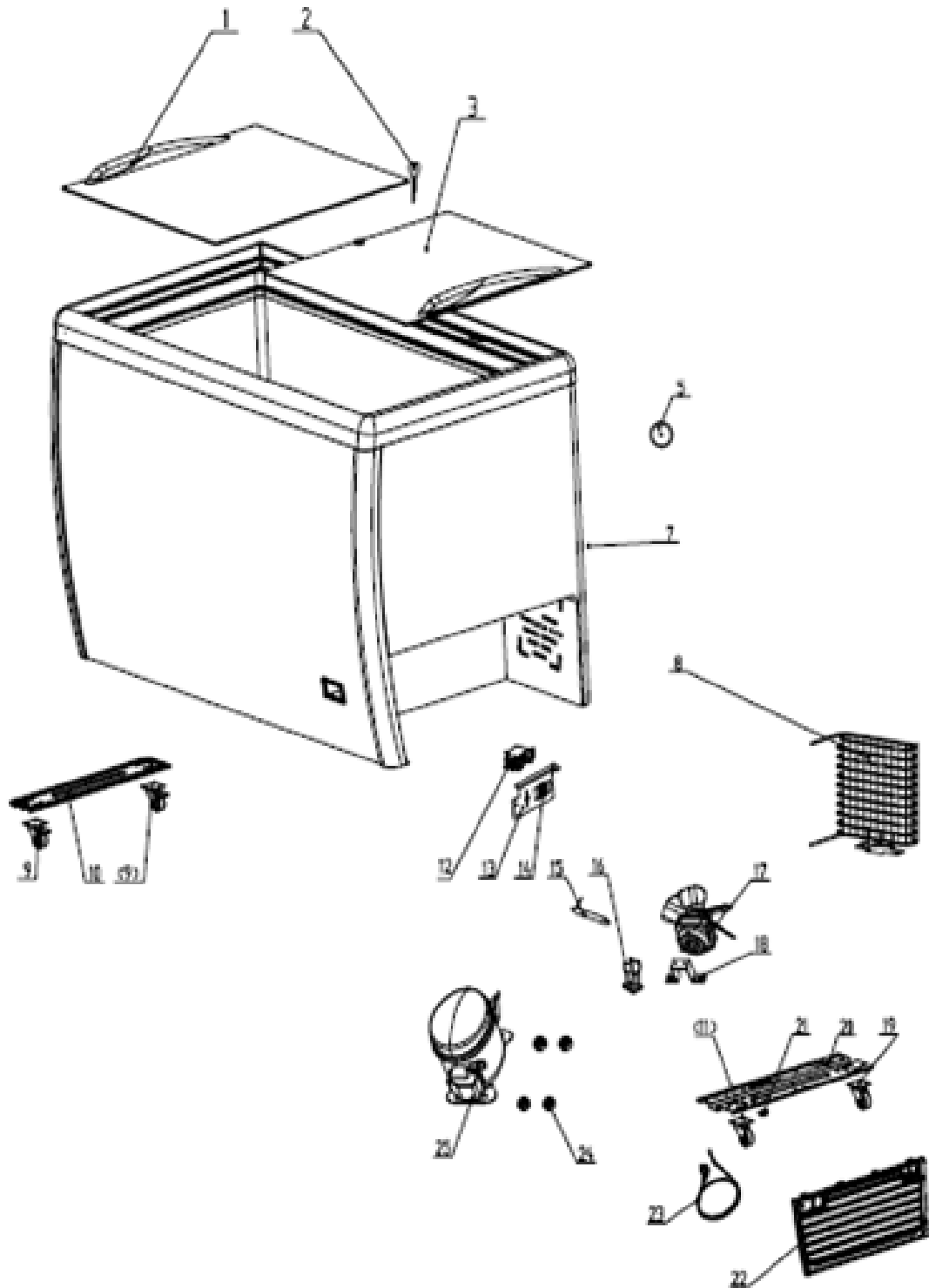

# Parts Breakdown

## Model FR-CN-0360-S 44588

Item No.	Description	Position	Item No.	Description	Position	Item No.	Description	Position
69423	Upper Glass Door for RI-360DC	1	28449	Thermostat for RI-360DC	12	28446	Castor without Lock for RI-360DC	19
41162	Key/Lock for RI-360DC	2	64766	Thermostat Support for RI-360DC	13	78720	Compressor Support for RI-360DC	20
69424	Lower Glass Door for RI-360DC	3	39587	Indicator Lamp for RI-360DC	14	28447	Shutter for RI-360DC	22
64763	Thermostat Cover for RI-360DC	5	39586	Filter for RI-360DC	15	28448	Plug for RI-360DC	23
64772	Cabinet Plastic Frame for RI-360DC	7	64441	Filter Support for RI-360DC	16	63503	Compressor (R290) for RI-360DC	24, 25
37874	Condenser for RI-360DC	8	28454	Cooling Fan Motor for RI-360DC	17			
28445	Caster with Lock for RI-360DC	9	64768	Fan Motor Support for RI-360DC	18			

## Glass Sneeze Guard

Item No.	Description	Position	Item No.	Description	Position	Item No.	Description	Position
AC126	Front Rail for RI-360DC		AC120	Screws and Metal Washers for Rails for RI-360DC		AC128	Front Glass for RI-360DC	
AC117	Side Rail for RI-360DC		AC121	Fasteners for Glass Panels for RI-360DC		AC129	Top Glass for RI-360DC	
AC118	Metal Plate for Side Rails for RI-360DC		AC127	Gasket of Glass for RI-360DC				
AC119	L-Shaped Bracket for RI-360DC		AC123	Side Glass for RI-360DC				

# Parts Breakdown

Model FR-CN-0460-S 44589

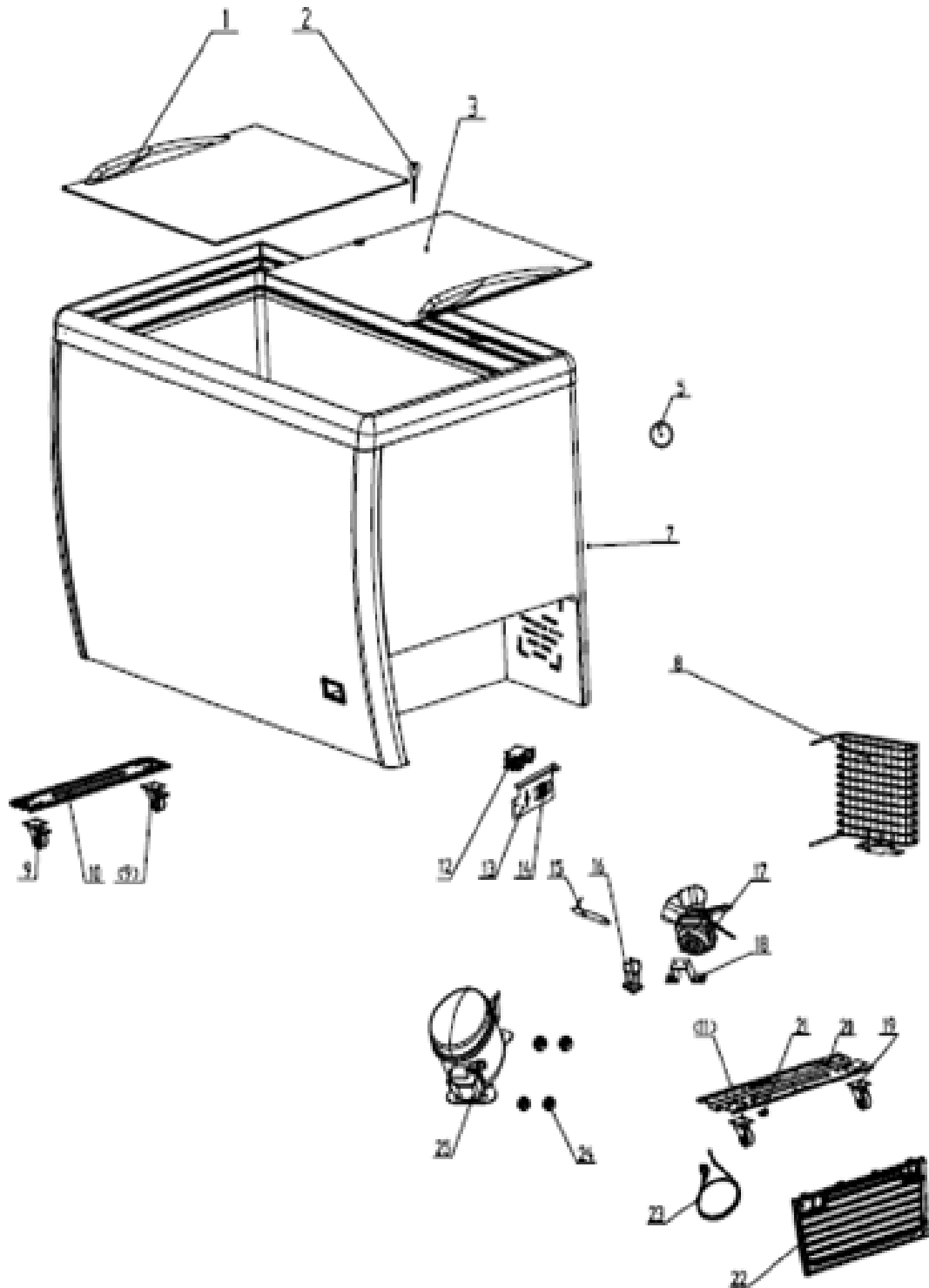

# Parts Breakdown

## Model FR-CN-0460-S 44589

Item No.	Description	Position	Item No.	Description	Position	Item No.	Description	Position
69425	Upper Glass Door for RI-460DC	1	69432	Thermostat for RI-460DC	12	69439	Casters without Brakes for RI-460DC	19
69426	Key for RI-460DC	2	69433	Thermostat Support for RI-460DC	13	69440	Compressor Panel for RI-460DC	20
69427	Lower Glass Door for RI-460DC	3	69434	Indicator Lamp for RI-460DC	14	69441	Side Panel for RI-460DC	22
69428	Thermostat Cover for RI-460DC	5	69435	Filter for RI-460DC	15	69442	Power Cord for RI-460DC	23
69429	Cabinet for RI-460DC	7	69436	Filter Support for RI-460DC	16	69443	Compressor R290 for RI-460DC	24, 25
69430	Condenser for RI-460DC	8	69437	Fan Motor for RI-460DC	17			
69431	Casters with Brakes for RI-460DC	9	69438	Fan Motor Support for RI-460DC	18			

## Glass Sneeze Guard

Item No.	Description	Position	Item No.	Description	Position	Item No.	Description	Position
AC130	Front Rail for RI-460DC		AC120	Screws and Metal Washers for Rails for RI-460DC		AC132	Front Glass for RI-460DC	
AC117	Side Rail for RI-460DC		AC121	Fasteners for Glass Panels for RI-460DC		AC133	Top Glass for RI-460DC	
AC118	Metal Plate for Side Rails for RI-460DC		AC131	Gasket of Glass for RI-460DC				
AC119	L-Shaped Bracket for RI-460DC		AC123	Side Glass for RI-460DC				

# Electrical Schematics

**Model FR-CN-0160-S** 44590

**Model FR-CN-0360-S** 44588

**Model FR-CN-0460-S** 44589

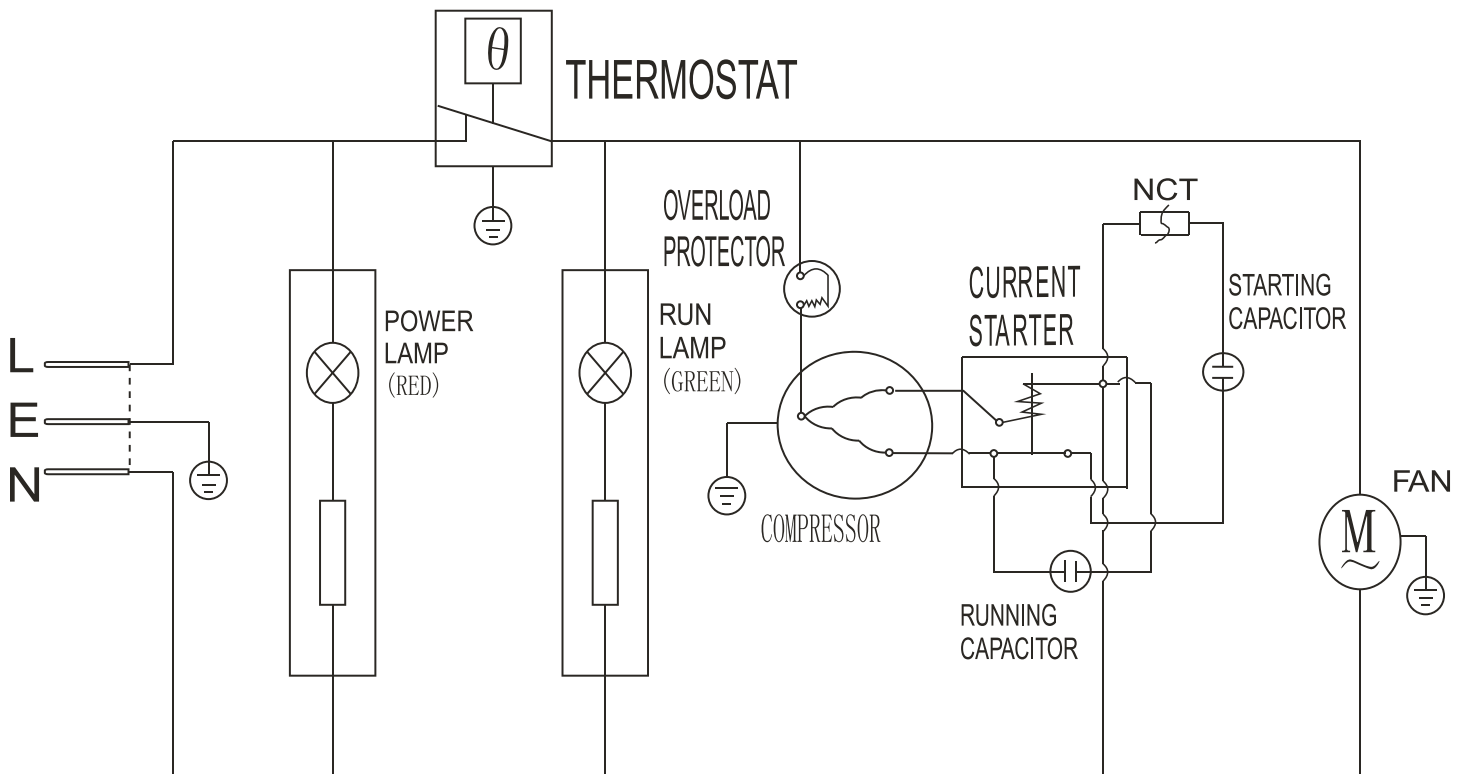







# Warranty Registration

Thank you for purchasing an Omcan product. To register your warranty for this product, complete the information below, tear off the card at the perforation and then send to the address specified below. You can also register online by visiting:

Merci d'avoir acheté un produit Omcan. Pour enregistrer votre garantie pour ce produit, complétez les informations ci-dessous, détachez la carte au niveau de la perforation, puis l'envoyer à l'adresse spécifiée ci-dessous. Vous pouvez également vous inscrire en ligne en visitant:

Gracias por comprar un producto Omcan usted. Para registrar su garantía para este producto, complete la información a continuación, cortar la tarjeta en la perforación y luego enviarlo a la dirección indicada a continuación. También puede registrarse en línea en:

<https://omcan.com/warranty-registration/>

For mailing in Canada

Pour postale au Canada

Por correo en Canadá

**OMCAN**

PRODUCT WARRANTY REGISTRATION

3115 Pepper Mill Court,

Mississauga, Ontario

Canada, L5L 4X5

For mailing in the US

Pour diffusion aux États-Unis

Por correo en los EE.UU.

**OMCAN**

PRODUCT WARRANTY REGISTRATION

4450 Witmer Industrial Estates, Unit 4,

Niagara Falls, New York

USA, 14305

*or email to: [service@omcan.com](mailto:service@omcan.com)*



Purchaser's Information

Name: \_\_\_\_\_

Address: \_\_\_\_\_

City: \_\_\_\_\_ Province or State: \_\_\_\_\_ Postal or Zip: \_\_\_\_\_

Country: \_\_\_\_\_

Dealer from which Purchased: \_\_\_\_\_

Dealer City: \_\_\_\_\_ Dealer Province or State: \_\_\_\_\_

Invoice: \_\_\_\_\_

Model Name: \_\_\_\_\_ Model Number: \_\_\_\_\_

Machine Description: \_\_\_\_\_

Date of Purchase (MM/DD/YYYY): \_\_\_\_\_

Would you like to extend the warranty?  Yes  No

Company Name: \_\_\_\_\_

Telephone: \_\_\_\_\_

Email Address: \_\_\_\_\_

Type of Company:

Restaurant  Bakery  Deli

Butcher  Supermarket  Caterer

Institution (specify): \_\_\_\_\_

Other (specify): \_\_\_\_\_

Serial Number: \_\_\_\_\_

Date of Installation (MM/DD/YYYY): \_\_\_\_\_

**Thank you for choosing Omcan | Merci d'avoir choisi Omcan | Gracias por elegir Omcan**



Since 1951 Omcan has grown to become a leading distributor of equipment and supplies to the North American food service industry. Our success over these many years can be attributed to our commitment to strengthen and develop new and existing relationships with our valued customers and manufacturers. Today with partners in North America, Europe, Asia and South America, we continually work to improve and grow the company. We strive to offer customers exceptional value through our qualified local sales and service representatives who provide convenient access to over 5,000 globally sourced products.

---

Depuis 1951 Omcan a grandi pour devenir un des “leaders” de la distribution des équipements et matériel pour l’industrie des services alimentaires en Amérique du Nord. Notre succès au cours de ces nombreuses années peut être attribué à notre engagement à renforcer et à développer de nouvelles et existantes relations avec nos clients et les fabricants de valeur. Aujourd’hui avec des partenaires en Amérique du Nord, Europe, Asie et Amérique du Sud, nous travaillons continuellement à améliorer et développer l’entreprise. Nous nous efforçons d’offrir à nos clients une valeur exceptionnelle grâce à nos ventes locales qualifiées et des représentants de service qui offrent un accès facile à plus de 5000 produits provenant du monde entier.

---

Desde 1951 Omcan ha crecido hasta convertirse en un líder en la distribución de equipos y suministros de alimentos en América del Norte industria de servicios. Nuestro éxito en estos años se puede atribuir a nuestro compromiso de fortalecer y desarrollar nuevas relaciones existentes con nuestros valiosos clientes y fabricantes. Hoy con socios de América del Norte, Europa, Asia y América del Sur, que trabajan continuamente para mejorar y crecer la empresa. Nos esforzamos por ofrecer a nuestros clientes valor excepcional a través de nuestro local de ventas y representantes de los servicios que proporcionan un fácil acceso a más de 5,000 productos con origen a nivel mundial.

