



## ***Cheese Cutters and Graters***

*Models GR-IT-0373, 0373-M, 0746, 1119, 0746-M, 1119-M, 1119-B  
Items 11401, 21719, 11402, 11403, 11404, 11405, 39884*

## ***Instruction Manual***



*Revised - 01/29/2019*



Toll Free: 1-800-465-0234  
Fax: 905-607-0234  
Email: [service@omcan.com](mailto:service@omcan.com)  
[www.omcan.com](http://www.omcan.com)

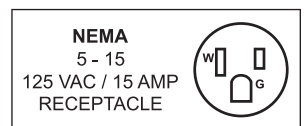

# ***Table of Contents***

Model GR-IT-0373 / Model GR-IT-0373-M / Model GR-IT-0746 / Model GR-IT-1119  
Model GR-IT-0746-M / Model GR-IT-1119-M / Model GR-IT-1119-B

---

<b>Section</b>	<b>Page</b>
General Information -----	3 - 4
Safety and Warranty -----	4 - 7
Technical Specifications -----	8
Installation and Operation -----	8 - 12
Maintenance -----	12 - 14
Troubleshooting -----	14 - 15
Parts Breakdown -----	16 - 27
Electrical Schematics -----	28 - 32
Notes -----	33 - 34
Warranty Registration -----	35



# General Information

---

Omcan Manufacturing and Distributing Company Inc., Food Machinery of America, Inc. dba Omcan and Omcan Inc. are not responsible for any harm or injury caused due to any person's improper or negligent use of this equipment. The product shall only be operated by someone over the age of 18, of sound mind, and not under the influence of any drugs or alcohol, who has been trained in the correct operation of this machine, and is wearing authorized, proper safety clothing. Any modification to the machine voids any warranty, and may cause harm to individuals using the machine or in the vicinity of the machine while in operation.

## CHECK PACKAGE UPON ARRIVAL

Upon receipt of an Omcan shipment please inspect for external damage. If no damage is evident on the external packaging, open carton to ensure all ordered items are within the box, and there is no concealed damage to the machine. If the package has suffered rough handling, bumps or damage (visible or concealed), please note it on the bill of lading before accepting the delivery and contact Omcan within 24 hours, so we may initiate a claim with the carrier. A detailed report on the extent of the damage caused to the machine must be filled out within three days, from the delivery date shown in the shipping documents. Omcan has no recourse for damaged products that were shipped collect or third party.

**Before operating any equipment, always read and familiarize yourself with all operation and safety instructions.**

Omcan would like to thank you for purchasing this machine. It's of the utmost importance to save these instructions for future reference. Also save the original box and packaging for shipping the equipment if servicing or returning of the machine is required.

---

Omcan Fabrication et distribution Compañie Limité et Food Machinery d'Amérique, dba Omcan et Omcan Inc. ne sont pas responsables de tout dommage ou blessure causé du fait que toute personne ait utilisé cet équipement de façon irrégulière. Le produit ne doit être exploité que par quelqu'un de plus de 18 ans, saine d'esprit, et pas sous l'influence d'une drogue ou d'alcool, qui a été formé pour utiliser cette machine correctement, et est vêtu de vêtements de sécurité approprié. Toute modification de la machine annule toute garantie, et peut causer un préjudice à des personnes utilisant la machine ou des personnes à proximité de la machine pendant son fonctionnement.

## VÉRIFIEZ LE COLIS DÈS RÉCEPTION

Dès réception d'une expédition d'Omcan veuillez inspecter pour dommages externes. Si aucun dommage n'est visible sur l'emballage externe, ouvrez le carton afin de s'assurer que tous les éléments commandés sont dans la boîte, et il n'y a aucun dommage dissimulé à la machine. Si le colis n'a subi aucune mauvaises manipulations, de bosses ou de dommages (visible ou cachée), notez-le sur le bond de livraison avant d'accepter la livraison et contactez Omcan dans les 24 heures qui suivent, pour que nous puissions engager une réclamation auprès du transporteur. Un rapport détaillé sur l'étendue des dommages causés à la machine doit être rempli dans un délai de trois jours, à compter de la date de livraison indiquée dans les documents d'expédition. Omcan n'a aucun droit de recours pour les produits endommagés qui ont été expédiés ou cueilli par un tiers transporteur.

# General Information

---

Avant d'utiliser n'importe quel équipement, toujours lire et vous familiariser avec toutes les opérations et les consignes de sécurité.

Omcan voudrais vous remercier d'avoir choisi cette machine. Il est primordial de conserver ces instructions pour une référence ultérieure. Également conservez la boîte originale et l'emballage pour l'expédition de l'équipement si l'entretien ou le retour de la machine est nécessaire.

Omcan Empresa De Fabricacion Y Distribucion Inc. Y Maquinaria De Alimentos De America, Inc. dba Omcan y Omcan Inc. no son responsables de ningun daño o perjuicio causado por cualquier persona inadecuada o el uso descuidado de este equipo. El producto solo podra ser operado por una persona mayor de 18 años, en su sano juicio y no bajo alguna influencia de droga o alcohol, y que este ha sido entrenado en el correcto funcionamiento de esta máquina, y ésta usando ropa apropiada y autorizada. Cualquier modificación a la máquina anula la garantía y puede causar daños a las personas usando la máquina mientras esta en el funcionamiento.

## REVISE EL PAQUETE A SU LLEGADA

Tras la recepcion de un envio Omcan favor inspeccionar daños externos. Si no hay daños evidentes en el empaque exterior, Habra el carton para asegurarse que todos los articulos solicitados estén dentro de la caja y no encuentre daños ocultos en la máquina. Si el paquete ha sufrido un manejo de poco cuidado, golpes o daños (visible o oculto) por favor anote en la factura antes de aceptar la entrega y contacte Omcan dentro de las 24 horas, de modo que podamos iniciar una reclamación con la compañía. Un informe detallado sobre los daños causados a la máquina debe ser llenado en el plazo de tres días, desde la fecha de entrega que se muestra en los documentos de envío. Omcan no tiene ningun recurso por productos dañados que se enviaron a recoger por terceros.

Antes de utilizar cualquier equipo, siempre lea y familiarizarse con todas las instrucciones de funcionamiento y seguridad.

Omcan le gustaría darle las gracias por la compra de esta máquina. Es de la mayor importancia para salvar estas instrucciones para futuras consultas. Además, guarda la caja original y el embalaje para el envío del equipo si servicio técnico o devolución de la máquina que se requiere.

# Safety and Warranty

---

## NORMAL USE, IMPROPER USE, OR NOT CORRECT USE

The machine describe in the present instructions manual for the use is foreseen to be drive from an only operator skilled and prepared on residual risks with competency and in a safe manner.



In its NORMAL USE; the machine can be used only to:  
1. Grate tough cheese, bread and biscuits.

# Safety and Warranty

---

The machine must not be used IN AN IMPROPER WAY; IN PARTICULAR:

1. It must not be used for domestic uses.
2. It must not be functioned with parameters different from those shown in the technical characteristics table.
3. When used with modalities different from those shown in the manual, the manufacturer declines every responsibility.
4. The user is responsible for the damages resulting from the lack of observance of the conditions described in the manual.
5. Not to tamper or damage intentionally nor remove or hide the labels.

The machine must not be used INCORRECTLY because some damages or injuries could be caused for the operator, in particular:

1. It is dangerous to move the machine when it is connected to the electric feeding.
2. It is dangerous to pull the power cable or the machine to disconnect the feeding plug.
3. It is dangerous to put weights on the machine or on the power cable.
4. It is dangerous to put the power cable on sharp or flammable objects.
5. It is dangerous to use the machine with a damaged power cable or with the control devices.
6. It is dangerous to leave the machine off with the power cable still connected.
7. It is dangerous to leave the loaded machine unsupervised.
8. It is dangerous to insert any type of object inside the motor ventilation cap.
9. It is dangerous to use flammable substances, corrosive or harmful cleaning agents.
10. It is dangerous to put the machine on top of objects.
11. It is dangerous to insert any type of object under the machine base or place clothes or other things between the machine feet and the working ground.
12. It is dangerous to plunge the machine in water or in other liquids.
13. It is dangerous that non-authorized personnel use the machine and with clothes different from that showed for the use.
14. It is dangerous to introduce the grinding neck and the grater mouth with products or objects having characteristics different from those showed in normal use, such as bones, frozen meat, non-food products and clothing.
15. It is dangerous to introduce in the grated product exit zone any object such as knives, blades, etc.
16. It is dangerous to function with the protection shelters and fixes not blocked or correctly removed.
17. It is dangerous to partially remove the protection pieces and danger signals.
18. It is dangerous to function without all the precautions about the residual risks adopted on behalf of the user.
19. It is dangerous to smoke or use free flame devices and manipulate incandescent materials, unless some suitable safety measures are adopted.



However, **the user is responsible** for damages resulting from not observing the specified normal use and conditions. For possible doubts you can enquire at the Authorized Assistance Center. Failure to follow proper safety instructions can be dangerous and can cause damage or injury.



Except where differently specified, the personnel who performs the installation interventions, connection, maintenance, reassembly and reuse, damages or breakdowns, demolition and dismantling must be a skilled personnel qualified in safety matter and educated on the residual risks. The personnel must be competent and perform in a safe matter with all other maintenance employees.

# Safety and Warranty

---

## ENVIRONMENTS, WORKING AND PASSING PLACES

The work environment must answer to the directive 89/654/CEE requirements. In the working area no foreign objects can be present. The employer, in the directive of 89/391/CEE, must follow the measures promoting the safety and health of the workers during the work. They must eliminate or reduce the residual risks as foreseen in the manual.

## WARNINGS ON THE RESIDUAL RISKS

### RESIDUAL RISK DUE TO THE FIXED PROTECTIONS REMOVAL, INTERVENTIONS ON BROKEN/WORN PARTS

The operator must not try to open or remove a protection measure or tamper a safety device.



In the phase of maintenance and cleaning, and during all further manual operations that happens to introduce the hands or other body parts in the machine's dangerous areas, a residual risk remains due above all to:

1. Hitting with machine manufacturing parts.
2. Grazing and/or abrasion with machine rough parts.
3. Injury from the sharpened parts.
4. Lacerations from a tool having sharpened parts.

The operator and maintenance personnel must be skilled for the intervention connected to the manual operations with open protections, must be trained on joined consequent risks and must be authorized from a responsible person.



### PROTECTION DEVICES ON THE MACHINE

The machine protections and safety devices must not be removed. If they must be removed for extraordinary maintenance requirements, some measures will have to be immediately adopted.

To put in evidence and to reduce amount of danger. The reassembling aspect of the protection or safety devices must happen as soon as the extraordinary circumstance has completed.

The machine transmission parts are completely isolated by means of fixed protections which do not allow access improper objects. For all safety functions including the control and check systems, well-tested components and safety principles have been used.

Grater group:

1. Taking into account the machine's modality and use, the moving elements are not isolated from the protections and safety devices.
2. On the handle and pressure group, a micro switch is placed, which stops the grater roll rotation so it is possible to access the grater mouth.
3. Fingers are prevented from accessing the grater roll as there is a fixed protection piece to stop this.

# Safety and Warranty

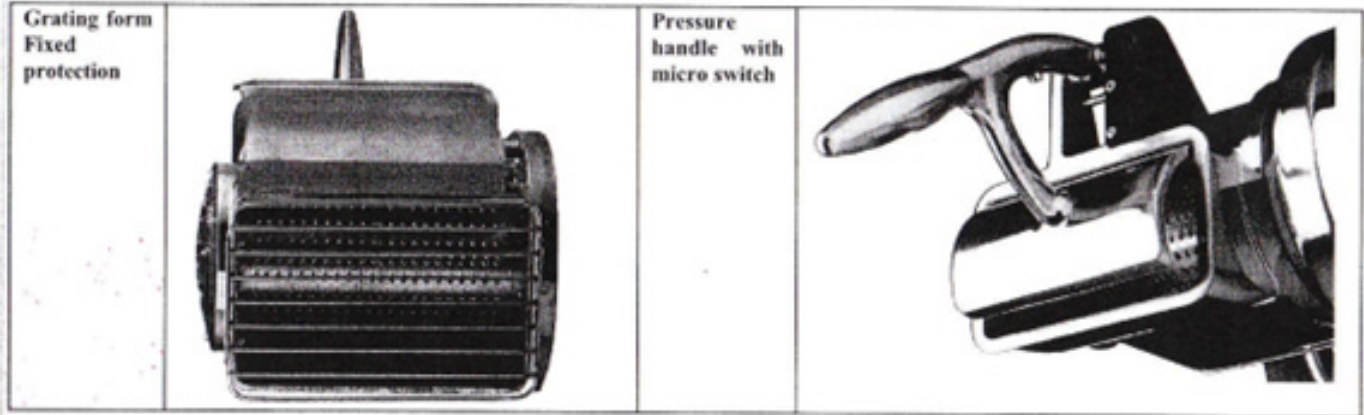

## 1 YEAR PARTS AND LABOUR BENCH WARRANTY

Within the warranty period, contact Omcan Inc. at 1-800-465-0234 to schedule a drop off to either an Omcan authorized service depot in the area, or to an Omcan Service warehouse to repair the equipment.

Unauthorized maintenance will void the warranty. Warranty covers electrical and part failures, not improper use.

Please see <https://omcan.com/disclaimer> for complete info.

### WARNING:

The packaging components are classified as normal solid urban waste and can therefore be disposed of without difficulty.

In any case, for suitable recycling, we suggest disposing of the products separately (differentiated waste) according to the current norms.

**DO NOT DISCARD ANY PACKAGING MATERIALS IN THE ENVIRONMENT!**

# Technical Specifications

Model	GR-IT-0373	GR-IT-0373-M	GR-IT-0746	GR-IT-1119	GR-IT-0746-M	GR-IT-1119-M	GR-IT-1119-B
HP	0.5		1	1.5	1	1.5	
Electrical	110V/60/1						
Microswitch	No	Yes	No		Yes		
Weight	16 lbs. / 7.3 kgs.		36 lbs. / 16 kgs.	42 lbs. / 19 kgs.	36 lbs. / 16 kgs.	44 lbs. / 20 kgs.	
Dimensions	10.35" x 11.4" x 11.75" 260 x 290 x 300mm		10.75" x 15.4" x 14.8" 270 x 390 x 276mm				
Item #	11401	21719	11402	11403	11404	11405	*39884

\*Brake motor included.

# Installation and Operation



The machine management is allowed only by authorized personnel and those of a sufficient technical experience.

Before switching on the machine perform the following operations:

- Read with attention the technical documentation.
- Know what protections and emergency devices are available on the machine, their location and functioning.

The non-authorized use of commercial parts and accessories altering the protections and safety devices can cause some malfunctions and danger for the operators. The operator must have received adequate training.

## WORKING POSITIONS AND OPERATORS TASKS

As described in the instructions manual, the machine is designed to be drive by an operator skilled and informed on the residual risks with competency and in a safe manner.

The normal working zone of the operator is:

1. The machine's frontal zone near the grater mouth (defined loading zone) in normal conditions of functioning is the loading operations of the food product, with the fixed covers closed and blocked.
2. The machine's front, the product dispenser in normal conditions of functioning is the location for withdrawal operations of the food product stored in the collect container, with the fixed covers in closed and blocked position.

## TRANSPORTATION, HANDLING AND STORING

All transportation and handling operations must be performed by informed and trained personnel and must have read and understood the safety instructions shown in this manual.

# Installation and Operation



1. Perform the machine handling and transportation always when it is off.
2. Verify that lifting means are use, it is able to support the loading weight and overall dimensions in safety conditions and that are approved and subjected to a regular maintenance.
3. Adopt all necessary measures to assure the maximum stability in relation to their mass.
4. Avoid making the machine suffer shaking or accidental collisions during the moving and the loading.
5. Perform the handling with continual movements, without pulls or repeated impulses.

## PACKING REMOVAL – OPENING MODALITY

### PACKING DESCRIPTION – HOW TO GET RID OF THE PACKING MATERIAL

The machines are package so that the liquids inside and organic matters are not present. There is a polyethylene cover around the machine which is then inserted in a cardboard box of adequate size. The empty spaces within the box are occupied with fill material.

Do not waste the packaging, but store it for possible transportation or locate a recycling agency for disposal.

It is an employer's obligation to be acquainted of the laws in its own country and observe these legislations. It is forbidden and liable to fines to leave the machine and electric equipment in the environment.

## PREPARATION PRELIMINARY OPERATIONS

### STABILITY

The machine stability is designed so that in normal functioning conditions, taking into account the climatic conditions, the machine can be used without reversal risk, fall or inopportune movement. Taking into account the conformation and the position of the machine, it will function without fastening it to the working ground.

### GRATER ROLL ROTATION



The operations indicated must be performed by the maintenance person (skilled personnel in the electric maintenance field of industrial machinery). For machines fed with three phase voltage (3 PE AC 400V 50Hz), slacken lightly the blockage wheel to not have a strong pressure on the drilled plate for the cutting knife. When turning on, verify the Archimedean screw / grater roll rotates counterclockwise. If there is clockwise rotation, switch off the machine, disconnect the plug, disassemble it, disconnects the two phase conductions and invert their position.

### FUNCTIONING DESCRIPTION

The control devices are designed and manufactured to handle normal service stresses and strains. The control devices are clearly visible, locatable and marked distinctly. The main control devices are shown:

# Installation and Operation

---

TYPE / COLOUR	REFERENCE / DESCRIPTION
Button / Black	"0" / button for the machine stop control
Button / White	"1" / button for the machine start control

## **STARTING**

The machine only starts with a voluntary action on the control device: white button "1" for the starting control.

## **STOP**

For the stop control push the black button "0". In case of momentary or extended stop, all food products must be removed to get the machine to function again.

## **FUNCTIONING SAFETY**

If the machine is under stress or is exposed to long functioning times or overload, the thermal protection function will stop the machine. In this case, wait until it is completely cooled before proceeding to the starting function.

## **VOLTAGE LACKING**

In the case of the electric feeding breaking off of the machine and being disconnected, the machine will only restarted after the electric feeding is back or there is re-connection to the power source.

## **STARTING**

The machine only starts with a voluntary action on the control device: white button "1" for the starting control.

## **STOP**

For the stop control push the black button "0". In case of momentary or extended stop, all food products must be removed to get the machine to function again.

## **FUNCTIONING SAFETY**

If the machine is under stress or is exposed to long functioning times or overload, the thermal protection function will stop the machine. In this case, wait until it is completely cooled before proceeding to the starting function.

## **VOLTAGE LACKING**

In the case of the electric feeding breaking of if the machine is disconnected, the machine will only be restarted after the electric feeding is back or there is re-connection to the power source.

## **PRESSURE OPENING - ONLY FOR UNITS WITH MICRO SWITCH**

Lifting the handle of the grater mouth stops the machine immediately because of the safety micro switch function. The machine can be restarted by lowering the handle and closing the mouth of the machine and pressing the on switch again.

# Installation and Operation

## CONTROLS AND VERIFICATIONS BEFORE STARTING

VERIFICATION / CONTROL	MODALITY AND CHECKS
Check that: <ul style="list-style-type: none"> <li>• Extraneous objects aren't on the machine, inside the grater mouth and in dispensing zone of the grated product.</li> </ul>	Visually check the indicated parts, check if objects or extraneous objects around the machine. Make sure there is not food product left over. In case of its presence, remove them.
Check the cleaning: <ul style="list-style-type: none"> <li>• Of the grater mouth, of the pressure and grater roll.</li> <li>• The external surface of the machine.</li> </ul>	Visually check all parts and surfaces to verify their cleaning. Disassemble to check internal parts. In case of mold or other types of dirtiness, follow the cleaning procedures indicated in chapter 5.
Check the integrity: <ul style="list-style-type: none"> <li>• Of the fixed protections.</li> <li>• Of the machine body, grater mouth, pressure and the grater roll.</li> </ul>	All fixed protections must perform their function. Verify the integrity of the external surface. The parts must be replaced at first sight of erosion or breaking.
Check the functionality: <ul style="list-style-type: none"> <li>• Of control system parts / control about the safety.</li> <li>• Of the control devices.</li> </ul>	All devices must perform desired function. The actuators and all parts must be changed at first sight of erosion or breaking.
Check the presence: <ul style="list-style-type: none"> <li>• Of strange noises.</li> <li>• Of oil trails on the ground and on the Archimedean screw.</li> </ul>	If there are strange noises, for example a seizing of mechanical break, stop immediately and contact maintenance personnel. Check during work and at the end of every use. Check if there are oil trails present. If there are any fluid drops, stop immediately and contact maintenance personnel.

Possible changes in parts must happen with manufacturer original parts or at least of quality, safety and equivalent characteristics. For analysis, contact the Authorized Assistance Center.

## PUT IN FUNCTION

The machine operator can put in function the machine if:

1. Positive check of preliminary operations.
2. Positive check of electric feeding.
3. Connection in power socket.
4. For the functioning of the GRATER GROUP.
  - a. Positive check of the direction of grater roll rotation.
  - b. Positive check result and verifications.
  - c. Concluded all checks and verified all safety instruments.
  - d. Place a gathering at the basin of the machine in correspondence of the food exit zone.
  - e. Activate the machine using the control device, turn to "1".
  - f. Introduce manually the food product within the grater mouth and drive it towards the grater roll by lowering the pressure roll.
  - g. At the end of the food product introduction, or when there is no room left in the basin, stop the machine

# Installation and Operation

---

using the control device, turn to “0”.



It is recommended to not use the machine without food product.

## **SWITCHING OFF**

Switching off the machine is completed as follows:

1. Before switching off, wait until all food has exited the machine.
2. Stop the machine by using the control device and switching it to “0”.
3. Disconnect the machine plug from the feeding socket.
4. Perform the cleaning interventions.

## **UNBLOCK IN CASE OF OBSTACLE**

During the normal function of the machine, introduction of hard and dry products could block the machine. The same result can occur if the electric feeding is broken. To be able to resume normal function, the blocked food product must be removed manually or the power cable is restored.

# Maintenance

---

## **MAINTENANCE PERSONNEL REQUIREMENTS**

The term “maintenance” is not only periodic checks but also the analysis of all problems that put the machine out of service. It is essential that for the maintenance, cleaning, parts change and breaks research, these actions are to be entrusted to a skilled personnel authorized by the employer. All operations of maintenance, cleaning and parts change, must be performed with the machine completely stopped and free of external feeding sources.

## **MAINTENANCE PRESCRIPTIONS**

### **PROTECTIONS REMOVAL AND/OR PROTECTION DEVICES**

For any interventions described in present chapter, it is necessary to remove the fixed protections. The removal can only happen by a trained maintenance personnel. At the end of the intervention, these protections must be replaced to their original position and fastened correctly. The maintenance must disconnect the machine completely before proceeding with the removal of the fixed protection.

### **BREAKS OR DAMAGES RESEARCH AND MOVING ELEMENTS UNBLOCKING**

The following indicates the interventions for the breaks or damages search and moving elements unblocking which can be performed by maintenance personnel.

## EXTRAORDINARY MAINTENANCE

In the event of breaks, revisions, mechanical and electrical damages, it is necessary to directly contact Omcan. The instructions for extraordinary maintenance does not appear in the instruction manual and must be explicitly requested to the manufacturer.

### CLEANING

#### PLEASE UNPLUG THE UNIT BEFORE CLEANING

**Warning:** It is forbidden to clean the machine while the grater or any grating part is working. Please make sure to empty and unplug the grater before starting the cleansing procedure.

**Cleansing frequency:** Please clean the grater at the end of each food processing cycle or on a daily basis.

**Cleansing procedure:** Please make sure you follow the below-mentioned cleansing procedure when cleaning all those parts that come in contact with food (i.e. pressure handle, cheese grater mouth and grating roll) and the grater case.

- Use a hard-bristled brush to remove any cheese residual from the roll teeth.
- Peel off all the cheese leftovers with scrapers.
- Dip a clean cloth in hot water mixed with neutral soap, and wring it out. Clean with this damp cloth the grater case and the grating parts (i.e. cheese grater mouth and grating roll). You can also use some dish-washing soap. To take off greasy use denatured alcohol. When using specific products for stainless steel cleansing, please make sure they are liquids. **DO NOT USE** creamy or abrasive products. **DO NOT USE** products that contain **CHLORINE**. **DO NOT USE** any type of water jet to clean this unit.

The machine, electrical equipment and machine board components must never be washed using water or with any kind of jets. Do not ever put the machine directly in the sink or under water. The machine hygiene level and the associated equipment is in conformance with applicable international standards requirements, but requires disassembly for the cleaning.

# Maintenance

FREQUENCY	PERSONNEL	MODALITY
At the end of every shift of work and before the daily use	Operator	PERIODS OF LONG INACTIVITY During long inactive periods pass over all steel surfaces (especially if stainless) with clothes soaked in Vaseline oil to spread a protective veil.
		PRODUCTS NOT TO USE <ul style="list-style-type: none"> <li>• Compressed air with jets towards the zones where food comes in contact and in the general direction of the machine.</li> <li>• Vapor equipment, detergent that contains CLORO (also if diluted) or its compounds such as: bleach, muriatic acid, marble cleaning, general decalcifying, products to clear the drain, etc. They can attack steel, staining and oxidizing is unavoidable. The described products can oxidize and corrode steel.</li> <li>• Steel wool, brushes or abrasive discs produced with other metals or alloys or tools that have previously cleaned other metals or alloys.</li> <li>• Detergents in abrasive dust.</li> <li>• Fuel, solvents or flammable and/or corrosive fluids.</li> <li>• Substances used to clean silver.</li> </ul>

# Troubleshooting

TYPE	POTENTIAL CAUSES	MODALITY AND COMPARISONS
Net voltage lacking	General black out.	Contact the electric distributor.
	Fuses or magneto thermals intervention place upstream of the machine feeding line.	After having eliminated the causes that have caused intervention in the protection device, restore it. If the problem persists, contact an electrician.
Functioning intervention	Protection device intervention inside the machine.	Contact an electrician. After having eliminated the causes of the intervention, restore it. In case of fuses intervention, change them with types of the same model, calibration and intervention curve.
	Grater handle lifted.	The machine can be restarted by lowering the handle and closing the mouth of the machine.
	Cause(s) not identifiable.	Direction contact Omcan.

# Troubleshooting

<b>The machine doesn't function: the Archimedean screw or grater roll does not rotate</b>	Feeding voltage lacking.	Check and restore the electric energy.
	Sectioning devices set on "OFF".	Turn the sectioning device to the "ON" position.
	Intervened fuses or non-functioning magento thermals.	Change the intervened fuses, check the magneto thermal switches state.
	Start button is not responding.	Check the START button efficiently and if problem persists contact Omcan.
	Thermal intervention due to overheating.	Wait until completely cooled before restarting the machine.
	Damaged micro switch.	Directly contact Omcan.

## REFERENCE

Item Number	Model Number	Description	Manufacturer Model Number
11401	GR-IT-0373	Cheese Grater 0.5 HP/373 W 110V/60/1 cQPSus	FGM-111
21719	GR-IT-0373-M	Cheese Grater 0.5 HP/373 W with Microswitch 110V/60/1 cQPSus	FGM-111M
11402	GR-IT-0746	Cheese Grater 1 HP/746 W 110V/60/1 cQPSus	FGS-101
11403	GR-IT-1119	Cheese Grater 1.5 HP/1119 W 110V/60/1 cQPSus	FGS-121
11404	GR-IT-0746-M	Cheese Grater 1 HP/746 W with Microswitch 110V/60/1 cQPSus	FGSM10
11405	GR-IT-1119-M	Cheese Grater 1.5 HP/1119 W with Microswitch 110V/60/1	FGSM15
39884	GR-IT-1119-B	Cheese Grater 1.5 HP/1119 W with Brake Motor 110V/60/1 cQPSus	FGSM15

# Parts Breakdown

Model GR-IT-0373 11401

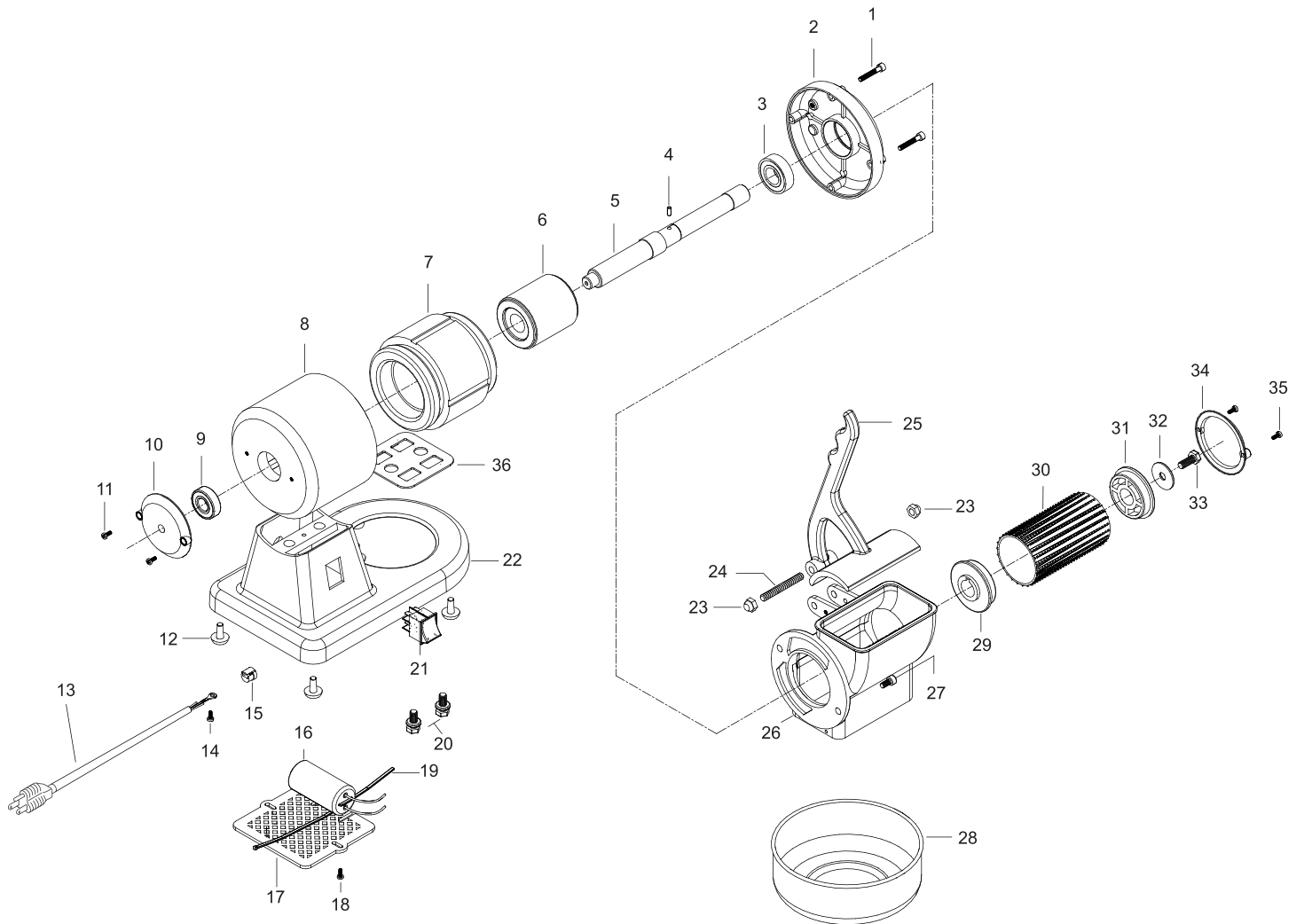

# Parts Breakdown

## Model GR-IT-0373 11401

Item No.	Description	Position	Item No.	Description	Position	Item No.	Description	Position
15372	Screw 5x25 (4 pcs.) for FGM-111	1	78001	Screw 3,5 x9, 5 for FGM-111	14	15369	Mouth Grattugia Mignon for FGM-111	26
15373	Cap Motor Low for FGM-111	2	15361	Cable from 12 for FGM-111	15	15367	Screw 6x12 (2 pcs.) for FGM-111	27
15354	Bearing 6004 ZZ for FGM-111	3	15358	Condenser 12.5 uF for FGM-111	16	15371	Cheese Box for FGM-111	28
15374	Spinetta DA 4x10 for FGM-111	4	15376	Closure of Protection for FGM-111	17	15366	Roller Flange Burglary for FGM-111	29
15378	Crankshaft for FGM-111	5	78003	Screw 3,5 x9, 5 (2 pcs.) for FGM-111	18	19377	Roller Grattugia Mignon for FGM-111	30
15375	Rotor for FGM-111	6	15359	Clamp for Condenser for FGM-111	19	19377	Roller Grattugia Miniature Steel for FGM-111	30
77999	Stator for FGM-111	7	15363	Screw 8x20 (2 pcs.) for FGM-111	20	15365	Roller Flat Flange for FGM-111	31
15355	Motor Housing for FGM-111	8	15461	Switch for FGM-111	21	15364	Washer, 8x32x2, 5 for FGM-111	32
15379	Bearing 6202 ZZ for FGM-111	9	15377	Aluminum Base for FGM-111	22	15363	Screw 8x20 for FGM-111	33
15352	Disc Locking ABS DA 80 mm. for FGM-111	10	78004	Nut DA 8x15 (2 pcs.) for FGM-111	23	15352	Disc Locking ABS DA 80 mm. for FGM-111	34
78001	Screw 3,5 x9, 5 (2 pcs.) for FGM-111	11	78005	Stud Threaded 8x55 for FGM-111	24	78006	Screw 3,5 x9, 5 (2 pcs.) for FGM-111	35
78002	Rubber Feet (4 pcs.) for FGM-111	12	15368	Miniature Aluminum Lever Grattugia for FGM-111	25	78007	Gasket Base for FGM-111	36
78000	Cable with Plug for FGM-111	13	15368	Lever Grattugia Mignon with Insert for FGM-111	25			

# Parts Breakdown

Model GR-IT-0373-M 21719

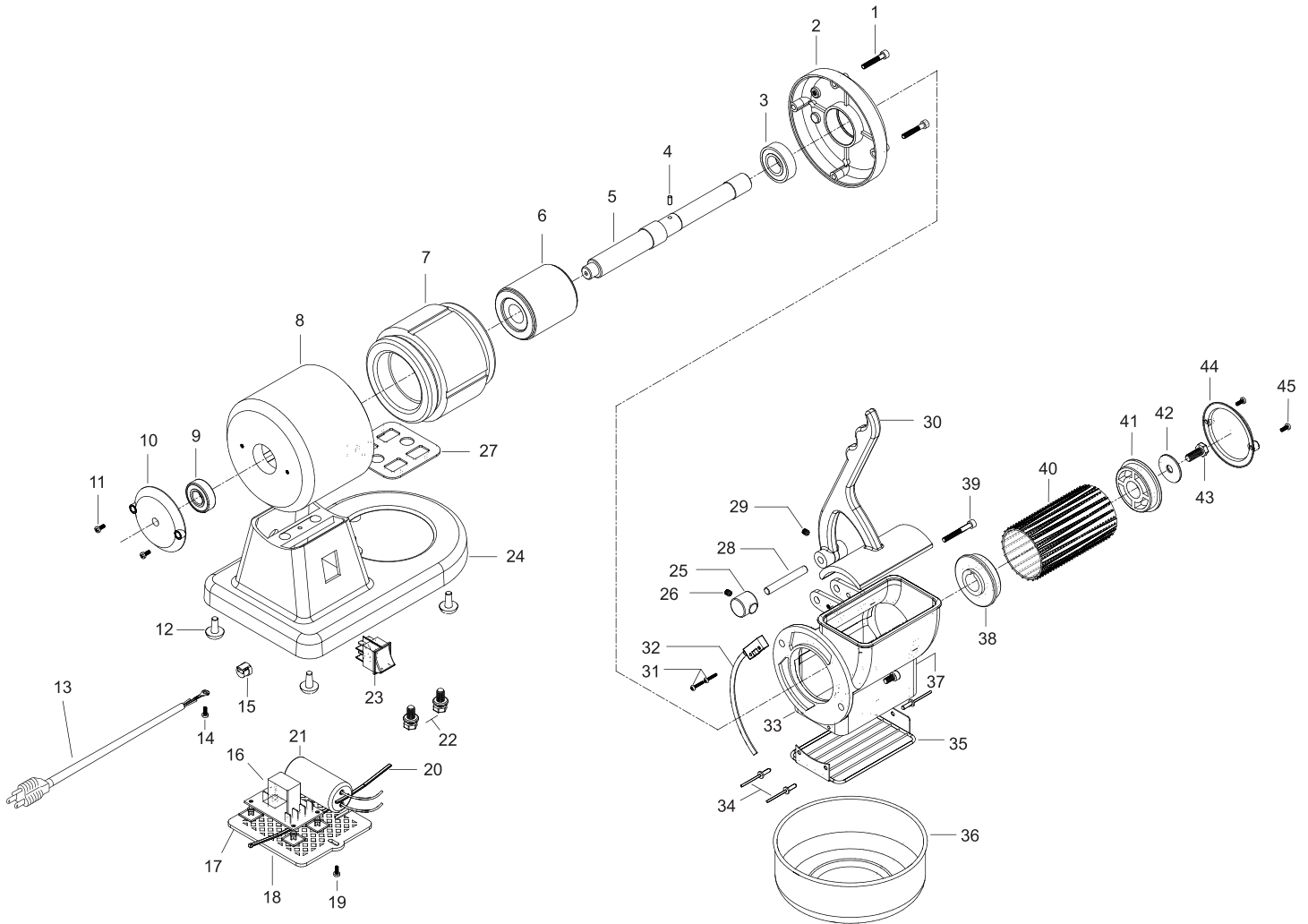

# Parts Breakdown

## Model GR-IT-0373-M 21719

Item No.	Description	Position	Item No.	Description	Position	Item No.	Description	Position
15372	Screw 5x25 (4 pcs.) for FGM-111M	1	78016	Sheet for FGM-111M	16	72910	Screw 3x12 (2 pcs.) for FGM-111M	31
15373	Cap Motor Low for FGM-111M	2	71428	Feet Adhesive Sheet (4 pcs.) for FGM-111M	17	17241	Micro Switch Magnetic for FGM-111M	32
15354	Bearing 6004 ZZ for FGM-111M	3	15376	Closure of Protection for FGM-111M	18	15369	Mouth Grattugia Mignon for FGM-111M	33
15374	Spinetta DA 4x10 for FGM-111M	4	78001	Screw 3,5 x9, 5 (2 pcs.) for FGM-111M	19	15370	Rivets (3 pcs.) for FGM-111M	34
15378	Crankshaft for FGM-111M	5	15359	Clamp for Condenser for FGM-111M	20	15431	Grille for FGM-111M	35
15375	Rotor for FGM-111M	6	15358	Condenser 12,5 uF for FGM-111M	21	15371	Cheese Box for FGM-111M	36
77999	Stator for FGM-111M	7	15363	Screw 8x20 (2 pcs.) for FGM-111M	22	15367	Screw 6x12 (2 pcs.) for FGM-111M	37
72884	Stator with Thermal for FGM-111M	7	15461	Switch for FGM-111M	23	15366	Roller Flange Burglary for FGM-111M	38
15355	Motor Housing for FGM-111M	8	15377	Aluminum Base for FGM-111M	24	72918	Screw 5x40 for FGM-111M	39
15379	Bearing 6202 ZZ for FGM-111M	9	15377	Base ABS for FGM-111M	24	19377	Roller Grattugia Mignon for FGM-111M	40
15352	Disc Locking ABS DA 80 mm. for FGM-111M	10	72904	Magnet Holder for FGM-111M	25	19377	Roller Grattugia Miniature Steel for FGM-111M	40
78001	Screw 3,5 x9, 5 (2 pcs.) for FGM-111M	11	72905	Wheat 5x6 for FGM-111M	26	15365	Flangia Rullo Piatta for FGM-111M	41
78002	Rubber Feet (4 pcs.) for FGM-111M	12	78007	Gasket Base for FGM-111M	27	15364	Washer, 8x32x2, 5 for FGM-111M	42
78000	Cable with Plug for FGM-111M	13	72906	Pin from 8x60 for FGM-111M	28	15363	Screw 8x20 for FGM-111M	43
78013	Cable with Plug Mod. Schuko for FGM-111M	13	15356	Wheat 6x6 for FGM-111M	29	15352	Disc Locking ABS DA 80 mm. for FGM-111M	44
78001	Screw 3,5 x9, 5 for FGM-111M	14	15368	Miniature Aluminum Lever Grattugia for FGM-111M	30	78001	Screw 3,5 x9, 5 (2 pcs.) for FGM-111M	45
15361	Cable from 12 for FGM-111M	15	15368	Lever Grattugia Mignon with Insert for FGM-111M	30			

# Parts Breakdown

Model GR-IT-0746 11402

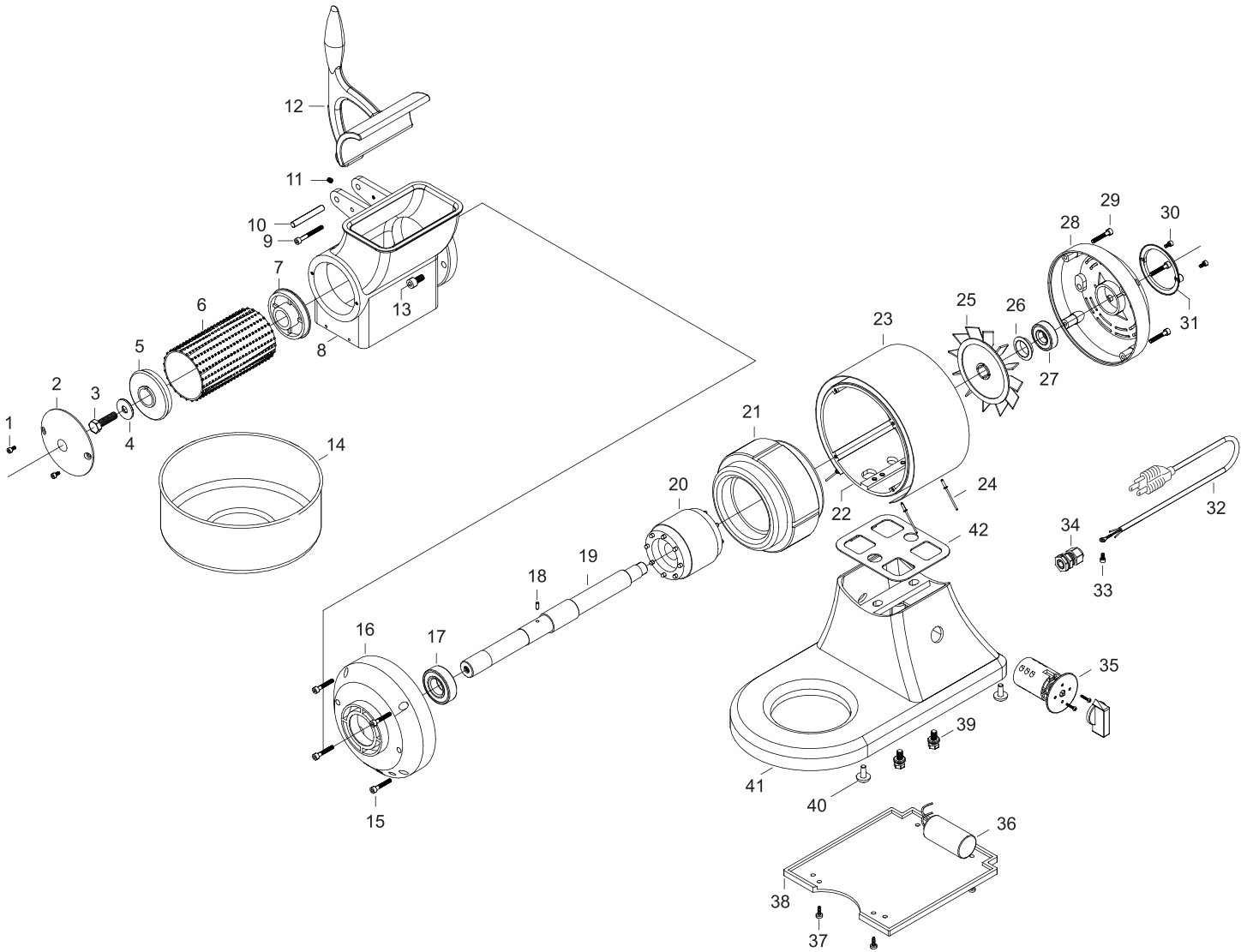

# Parts Breakdown

## Model GR-IT-0746 11402

Item No.	Description	Position	Item No.	Description	Position	Item No.	Description	Position
15351	Screw 4x8 (2 pcs.) for FGS-101	1	15353	Screw 5x30 (4 pcs.) for FGS-101	15	15351	Screw 4x8 (2 pcs.) for FGS-101	30
15418	Closing Disc ABS 100 mm. for FGS-101	2	15433	Shell with Hub for FGS-101	16	15352	Disc Locking ABS DA 80 mm. for FGS-101	31
15419	Screw Fixing Roller 10x35 for FGS-101	3	15434	Bearing 6205 2RS for FGS-101	17	78009	Cable with Plug Mod.Schuko for FGS-101	32
15420	Washer 10x30x2 for FGS-101	4	17244	Spinetta Stainless Steel 4x10 for FGS-101	18	15351	Screw 4x8 for FGS-101	33
17885	X Flange Standard Roller for FGS-101	5	15436	Crankshaft for FGS-101	19	15437	Gland PG9/11 for FGS-101	34
17823	Drum for FGS-101	6	15383	Rotor for FGS-101	20	17701	Bipolar Switch for FGS-101	35
17885	X Flange Standard Roller for FGS-101	7	78008	Stator 4 Poles for FGS-101	21	17701	Switch Pole for FGS-101	35
15430	Mouth Grattugia for FGS-101	8	15438	Motor Housing Open for FGS-101	22	15413	Condenser 16 uF for FGS-101	36
15423	Screw 5x45 for FGS-101	9	15385	Steel Band Short for FGS-101	23	15412	Screw 4.8 x12 (4 pcs.) for FGS-101	37
15424	Pin from 8x57 for FGS-101	10	15370	Rivets (4 pcs.) for FGS-101	24	15411	ABS Seat for FGS-101	38
15356	Wheat 6x6 for FGS-101	11	15415	Fan for FGS-101	25	15440	Screw 8x25 (2 pcs.) for FGS-101	39
15425	Lever Aluminum Grating for FGS-101	12	15414	Fixing Ring Fan for FGS-101	26	78024	Rubber Feet (4 pcs.) for FGS-101	40
15425	Grattugia Lever with Insert for FGS-101	12	15381	Bearing 6203 ZZ for FGS-101	27	15439	Base for FGS-101	41
15410	Screw 8x22 (2 pcs.) for FGS-101	13	15380	Cap Fan for FGS-101	28	78010	Gasket Base for FGS-101	42
17243	Cheese Pan for FGS-101	14	15353	Screw 5x30 (4 pcs.) for FGS-101	29			

# Parts Breakdown

Model GR-IT-1119 11403

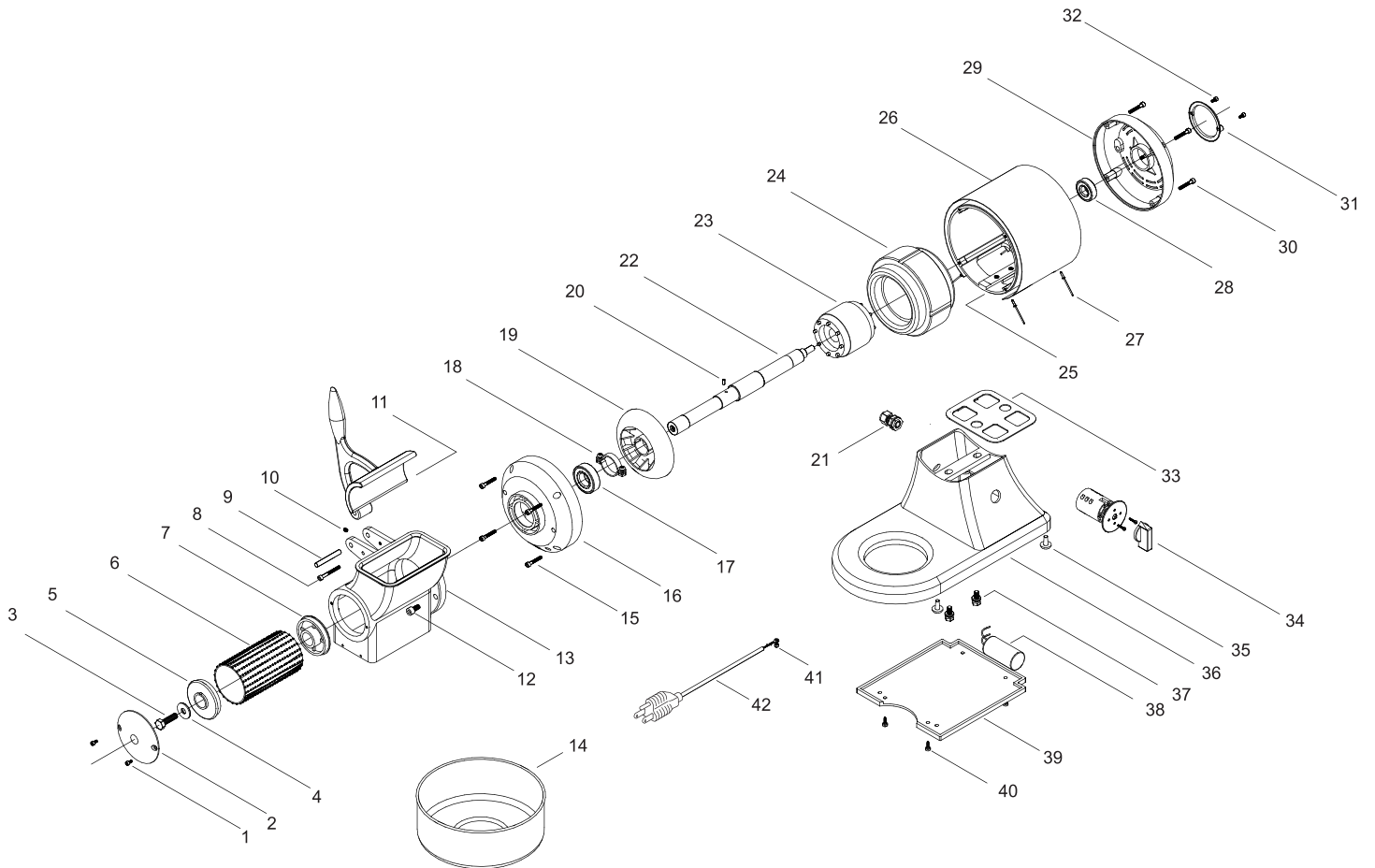

# Parts Breakdown

## Model GR-IT-1119 11403

Item No.	Description	Position	Item No.	Description	Position	Item No.	Description	Position
15351	Screw 4x8 (2 pcs.) for FGS-121	1	15433	Shell with Hub for FGS-121	16	15352	Disc Locking ABS DA 80 mm. for FGS-121	31
15418	Closing Disc ABS 100 mm. for FGS-121	2	15434	Bearing 6205 2RS for FGS-121	17	15351	Screw 4x8 (2 pcs.) for FGS-121	32
15419	Screw Fixing Roller 10x35 for FGS-121	3	15414	Fixing Ring Fan for FGS-121	18	78025	Gasket Base for FGS-121	33
15420	Washer 10x30x2 for FGS-121	4	15415	Fan for FGS-121	19	15463	Bipolar Switch for FGS-121	34
17885	X Flange Standard Roller for FGS-121	5	17244	Spinetta Stainless Steel 4x10 for FGS-121	20	15463	Switch Pole for FGS-121	34
17823	Drum for FGS-121	6	15437	Gland PG9/11 for FGS-121	21	78012	Rubber Feet (4 pcs.) for FGS-121	35
17885	X Flange Standard Roller for FGS-121	7	15436	Crankshaft for FGS-121	22	15439	Base for FGS-121	36
15423	Screw 5x45 for FGS-121	8	15446	Rotor for FGS-121	23	15440	Screw 8x25 (2 pcs.) for FGS-121	37
15424	Pin from 8x57 for FGS-121	9	78011	6 Pole Stator for FGS-121	24	19379	Condenser 25 uF for FGS-121	38
15356	Wheat 6x6 for FGS-121	10	15417	Long Fan Housing for FGS-121	25	15411	ABS Seat for FGS-121	39
15425	Grattugia Lever with Insert for FGS-121	11	15386	Steel Band Fan for FGS-121	26	15412	Screw 4.8 x12 (4 pcs.) for FGS-121	40
15410	Screw 8x22 (2 pcs.) for FGS-121	12	15370	Rivets (4 pcs.) for FGS-121	27	15351	Screw 4x8 for FGS-121	41
15430	Mouth Grattugia for FGS-121	13	15381	Bearing 6203 ZZ for FGS-121	28	78013	Cable with Plug Mod.Schuko for FGS-121	42
17243	Cheese Pan for FGS-121	14	15380	Cap Fan for FGS-121	29			
15353	Screw 5x30 (4 pcs.) for FGS-121	15	15353	Screw 5x30 (4 pcs.) for FGS-121	30			

# Parts Breakdown

Model GR-IT-0746-M 11404

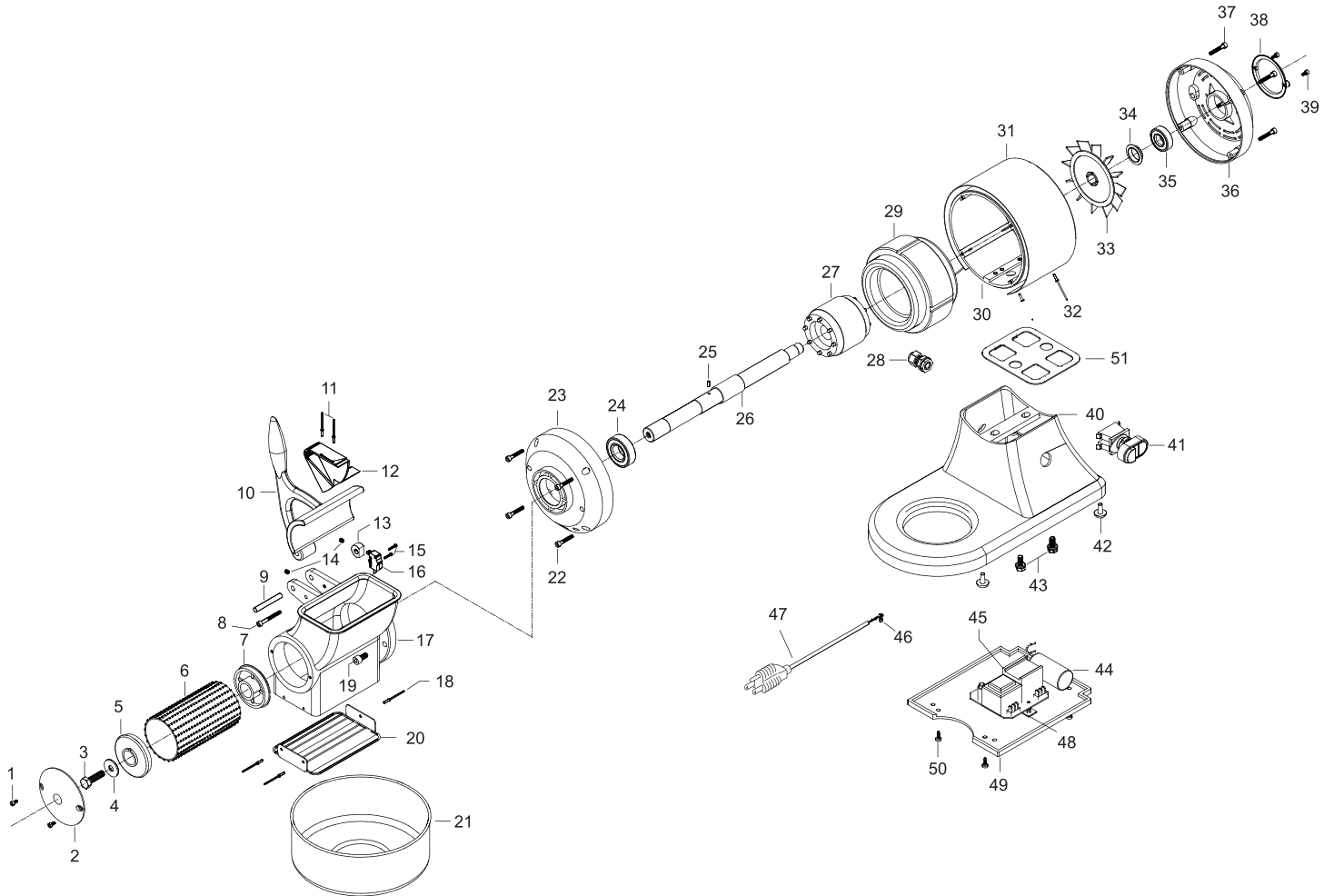

# Parts Breakdown

## Model GR-IT-0746-M 11404

Item No.	Description	Position	Item No.	Description	Position	Item No.	Description	Position
15351	Screw 4x8 (2 pcs.) for FGSM10	1	71395	Screw 2.8 x15 (2 pcs.) for FGSM10	15	15414	Fixing Ring Fan for FGSM10	34
15418	Closing Disc ABS 100 mm. for FGSM10	2	17241	Micro Switch Mechanical for FGSM10	16	15381	Bearing 6203 ZZ for FGSM10	35
15419	Screw Fixing Roller 10x35 for FGSM10	3	15430	Mouth Grattugia for FGSM10	17	15380	Cap Fan for FGSM10	36
15420	Washer 10x30x2 for FGSM10	4	15370	Rivets (3 pcs.) for FGSM10	18	15353	Screw 5x30 (4 pcs.) for FGSM10	37
17885	X Flange Standard Roller for FGSM10	5	15410	Screw 8x22 (2 pcs.) for FGSM10	19	15352	Disc Locking ABS DA 80 mm. for FGSM10	38
17885	X Flange Steel Roller for FGSM10	5	15431	Grille for FGSM10	20	15351	Screw 4x8 (2 pcs.) for FGSM10	39
17823	Drum for FGSM10	6	17243	Cheese Pan for FGSM10	21	15439	Base for FGSM10	40
17823	Roller Grattugia Milled for FGSM10	6	15353	Screw 5x30 (4 pcs.) for FGSM10	22	71422	Keyboard 24V for FGSM10	41
17823	Roller Scratched Steel with Flange for FGSM10	6	15433	Shell with Hub for FGSM10	23	78024	Rubber Feet (4 pcs.) for FGSM10	42
17885	X Flange Standard Roller for FGSM10	7	15434	Bearing 6205 2RS for FGSM10	24	15440	Screw 8x25 (2 pcs.) for FGSM10	43
17885	X Flange Steel Roller for FGSM10	7	17244	Spinetta Stainless Steel 4x10 for FGSM10	25	15413	Condenser 16 uF for FGSM10	44
15423	Screw 5x45 for FGSM10	8	15436	Crankshaft for FGSM10	26	78016	Sheet Low Voltage 24V for FGSM10	45
15423	Pin from 8x57 for FGSM10	9	15383	Rotor for FGSM10	27	15351	Screw 4x8 for FGSM10	46
15425	Lever Aluminum Grating for FGSM10	10	15437	Gland PG9/11 for FGSM10	28	78013	Cable with Plug Mod.Schuko for FGSM10	47
15425	Lever Grater with Insert for FGSM10	10	78008	Stator 4 Poles for FGSM10	29	71428	Feet Adhesive Sheet (4 pcs.) for FGSM10	48
15370	Rivets (2 pcs.) for FGSM10	11	15438	Motor Housing Open for FGSM10	30	15411	ABS Seat for FGSM10	49
17700	Micro Switch Cover for FGSM10	12	15383	Steel Band Short for FGSM10	31	15412	Screw 4.8 x12 (4 pcs.) for FGSM10	50
71394	Nottolino for FGSM10	13	15370	Rivets (4 pcs.) for FGSM10	32	78010	Gasket Base for FGSM10	51
15356	Wheat 6x6 (2 pcs.) for FGSM10	14	15415	Fan for FGSM10	33			

# Parts Breakdown

**Model GR-IT-1119-M** 11405

**Model GR-IT-1119-B** 39884

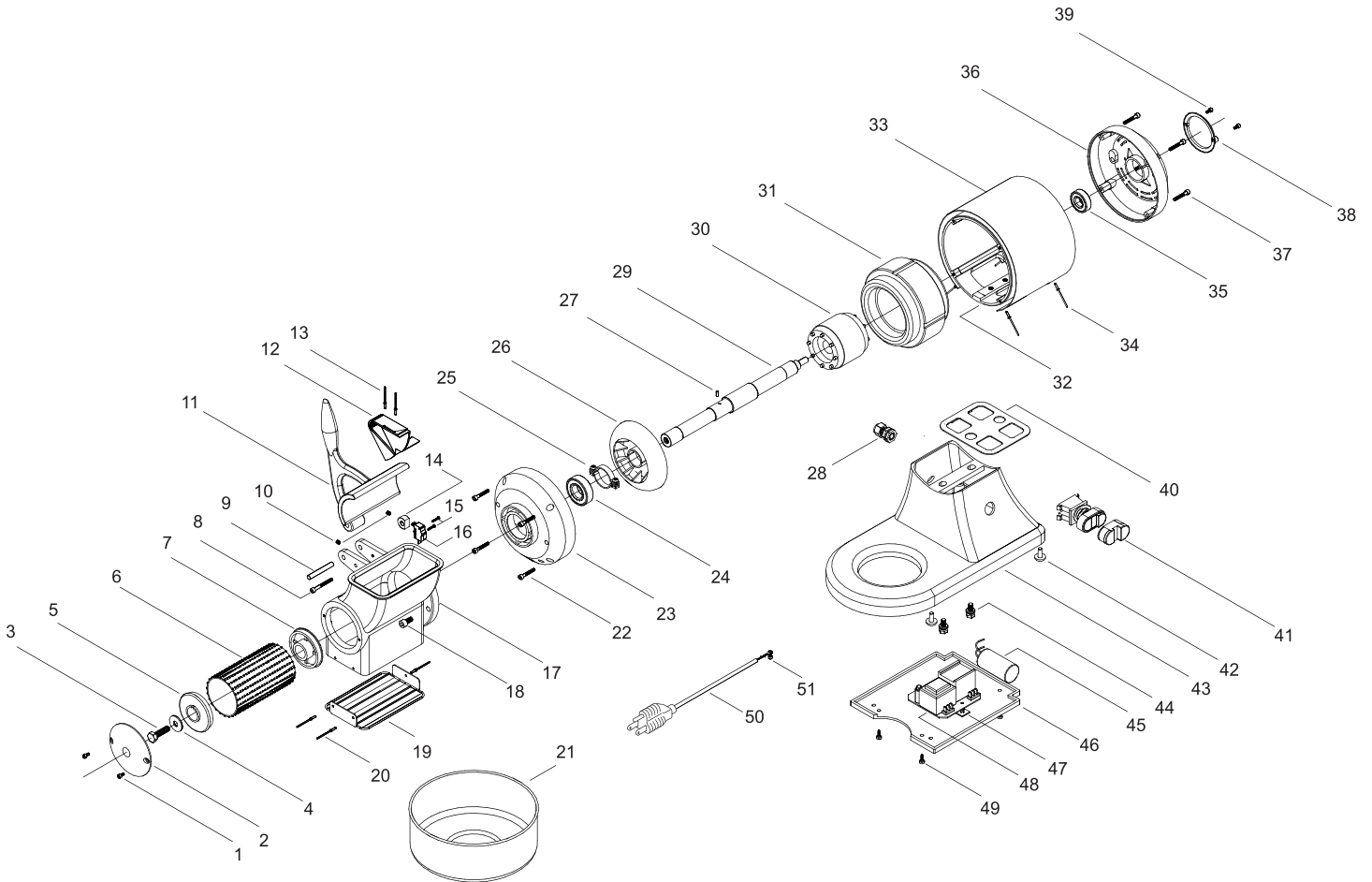

# Parts Breakdown

**Model GR-IT-1119-M** 11405

**Model GR-IT-1119-B** 39884

Item No.	Description	Position	Item No.	Description	Position	Item No.	Description	Position
15351	Screw 4x8 (2 pcs.) for FGSM15	1	15430	Mouth Grattugia for FGSM15	17	15381	Bearing 6203 ZZ for FGSM15	35
15418	Closing Disc ABS 100 mm. for FGSM15	2	15410	Screw 8x22 (2 pcs.) for FGSM15	18	15380	Cap Fan for FGSM15	36
15419	Screw Fixing Roller 10x35 for FGSM15	3	15431	Grille for FGSM15	19	15353	Screw 5x30 (4 pcs.) for FGSM15	37
15420	Washer 10x30x2 for FGSM15	4	15370	Rivets (3 pcs.) for FGSM15	20	15352	Disc Locking Abs DA 80 mm. for FGSM15	38
17885	X Flange Standard Roller for FGSM15	5	17243	Cheese Pan for FGSM15	21	15351	Screw 4x8 (2 pcs.) for FGSM15	39
17885	X Flange Steel Roller for FGSM15	5	15353	Screw 5x30 (4 pcs.) for FGSM15	22	78025	Gasket Base for FGSM15	40
17823	Drum for FGSM15	6	15433	Shell with Hub for FGSM15	23	71422	Keyboard 24V for FGSM15	41
17885	X Flange Standard Roller for FGSM15	7	15434	Bearing 6205 2RS for FGSM15	24	78012	Rubber Feet (4 pcs.) for FGSM15	42
15423	Screw 5x45 for FGSM15	8	15414	Fixing Ring Fan for FGSM15	25	15439	Base for FGSM15	43
15424	Pin from 8x57 for FGSM15	9	15415	Fan for FGSM15	26	15440	Screw 8x25 (2 pcs.) for FGSM15	44
15356	Wheat 6x6 (2 pcs.) for FGSM15	10	17244	Spinetta Stainless Steel 4x10 for FGSM15	27	19379	Condenser 25 uF for FGSM15	45
15425	Lever Aluminum Grating for FGSM15	11	15437	Gland PG9/11 for FGSM15	28	15411	ABS Seat for FGSM15	46
71391	Lever Grater with Insert for FGSM15	11	15436	Crankshaft for FGSM15	29	71428	Feet Adhesive Sheet (4 pcs.) for FGSM15	47
71392	Micro Switch Cover for FGSM15	12	15446	Rotor for FGSM15	30	44762	Sheet Low Voltage 24V for FGSM15	48
15370	Rivets (2 pcs.) for FGSM15	13	78011	6 Pole Stator for FGSM15	31	15412	Screw 4.8 x12 (4 pcs.) for FGSM15	49
71394	Nottolino for FGSM15	14	15417	Long Fan Housing for FGSM15	32	78013	Cable with Plug Mod.Schuko for FGSM15	50
71395	Screw 2.8 x15 (2 pcs.) for FGSM15	15	15386	Steel Band Fan for FGSM15	33	15351	Screw 4x8 for FGSM15	51
71396	Micro Switch Mechanical for FGSM15	16	15378	Rivets (4 pcs.) for FGSM15	34			

# Electrical Schematics

**Model GR-IT-0373** 11401

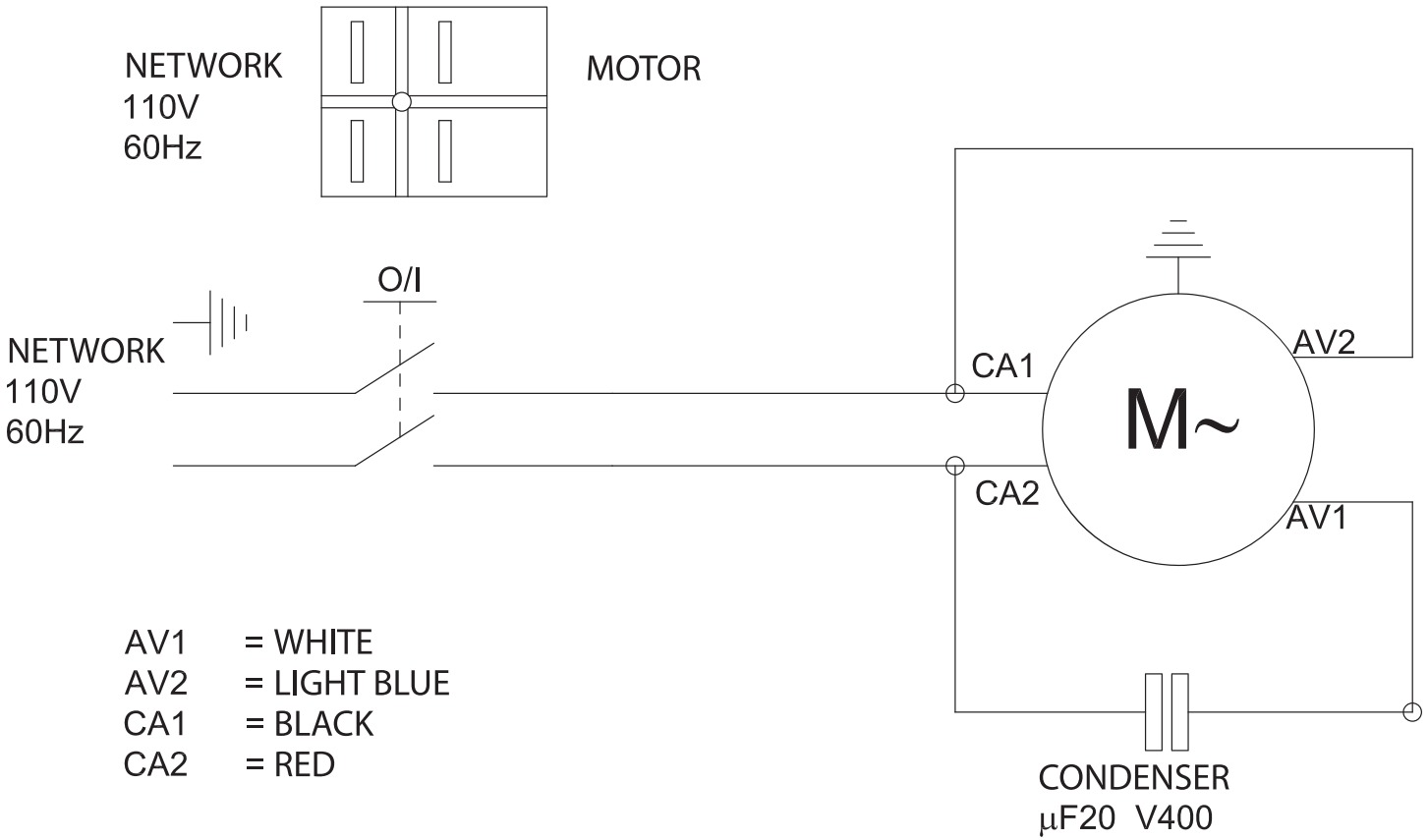

# Electrical Schematics

**Model GR-IT-0373-M** 21719

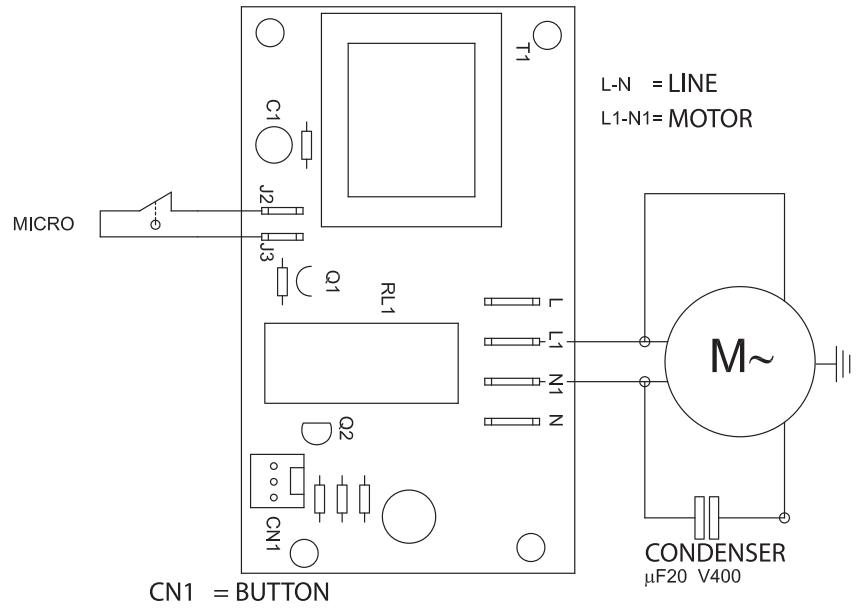
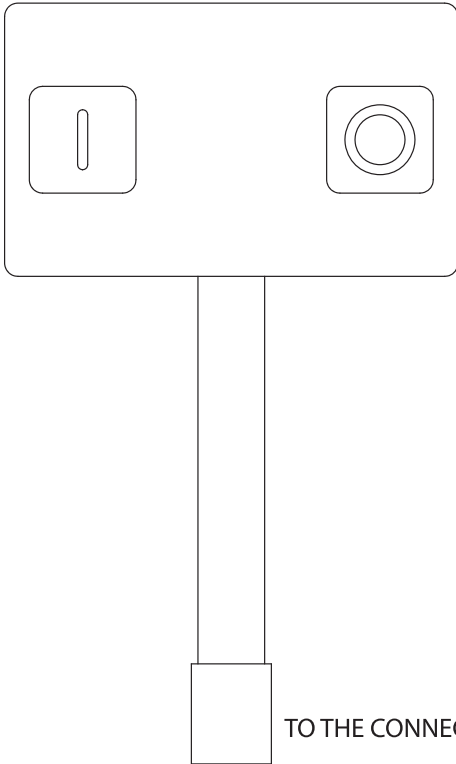

# Electrical Schematics

**Model GR-IT-0746** 11402

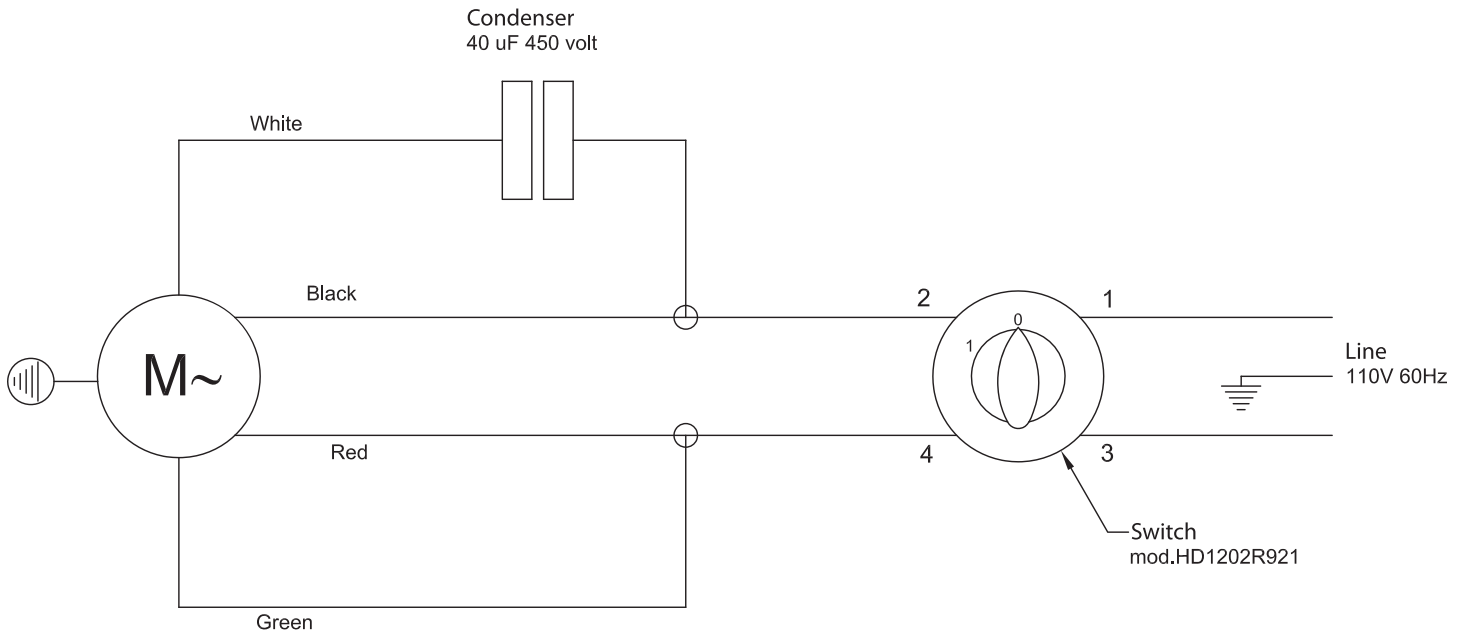

# Electrical Schematics

**Model GR-IT-1119** 11403

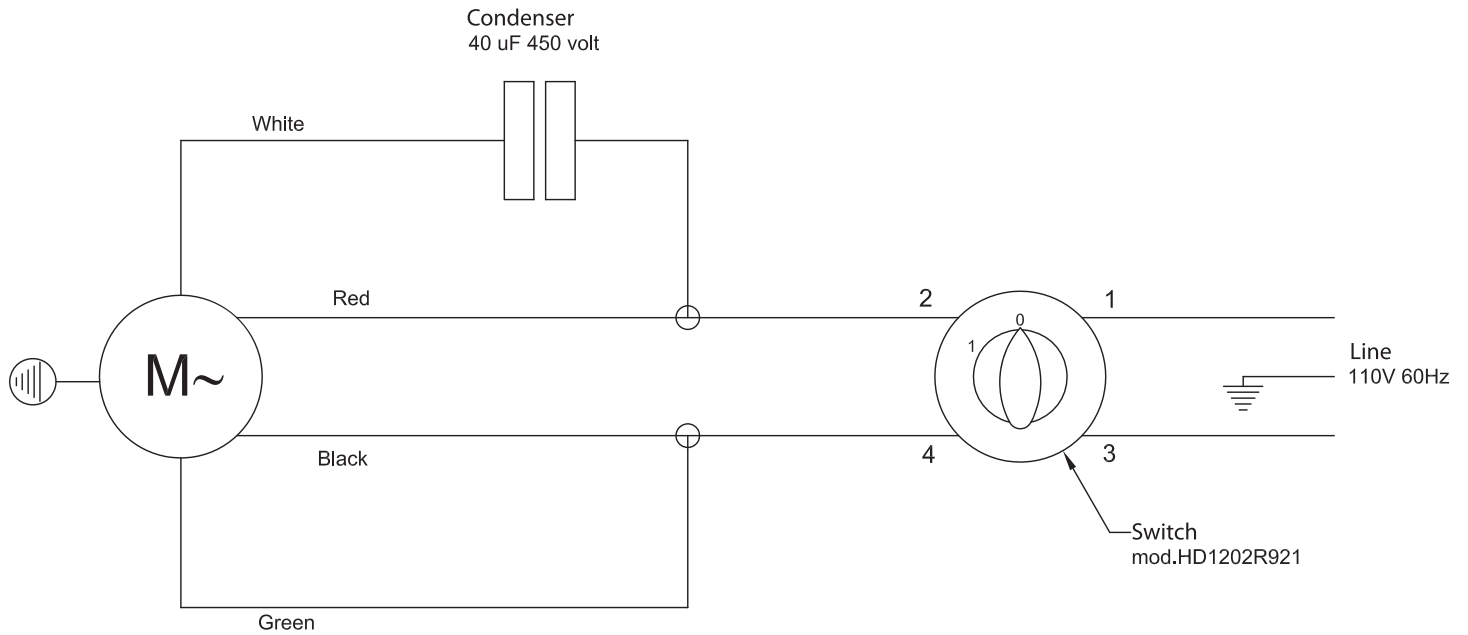









# Warranty Registration

Thank you for purchasing an Omcan product. To register your warranty for this product, complete the information below, tear off the card at the perforation and then send to the address specified below. You can also register online by visiting:

Merci d'avoir acheté un produit Omcan. Pour enregistrer votre garantie pour ce produit, complétez les informations ci-dessous, détachez la carte au niveau de la perforation, puis l'envoyer à l'adresse spécifiée ci-dessous. Vous pouvez également vous inscrire en ligne en visitant:

Gracias por comprar un producto Omcan usted. Para registrar su garantía para este producto, complete la información a continuación, cortar la tarjeta en la perforación y luego enviarlo a la dirección indicada a continuación. También puede registrarse en línea en:

<https://omcan.com/warranty-registration/>

For mailing in Canada

Pour postale au Canada

Por correo en Canadá

**OMCAN**

PRODUCT WARRANTY REGISTRATION

3115 Pepper Mill Court,

Mississauga, Ontario

Canada, L5L 4X5

For mailing in the US

Pour diffusion aux États-Unis

Por correo en los EE.UU.

**OMCAN**

PRODUCT WARRANTY REGISTRATION

4450 Witmer Industrial Estates, Unit 4,

Niagara Falls, New York

USA, 14305

*or email to: [service@omcan.com](mailto:service@omcan.com)*



Purchaser's Information

Name: \_\_\_\_\_

Address: \_\_\_\_\_

City: \_\_\_\_\_ Province or State: \_\_\_\_\_ Postal or Zip: \_\_\_\_\_

Country: \_\_\_\_\_

Dealer from which Purchased: \_\_\_\_\_

Dealer City: \_\_\_\_\_ Dealer Province or State: \_\_\_\_\_

Invoice: \_\_\_\_\_

Model Name: \_\_\_\_\_ Model Number: \_\_\_\_\_

Machine Description: \_\_\_\_\_

Date of Purchase (MM/DD/YYYY): \_\_\_\_\_

Would you like to extend the warranty?  Yes  No

Company Name: \_\_\_\_\_

Telephone: \_\_\_\_\_

Email Address: \_\_\_\_\_

Type of Company:

Restaurant  Bakery  Deli

Butcher  Supermarket  Caterer

Institution (*specify*): \_\_\_\_\_

Other (*specify*): \_\_\_\_\_

Serial Number: \_\_\_\_\_

Date of Installation (MM/DD/YYYY): \_\_\_\_\_

**Thank you for choosing Omcan | Merci d'avoir choisi Omcan | Gracias por elegir Omcan**



Since 1951 Omcan has grown to become a leading distributor of equipment and supplies to the North American food service industry. Our success over these many years can be attributed to our commitment to strengthen and develop new and existing relationships with our valued customers and manufacturers. Today with partners in North America, Europe, Asia and South America, we continually work to improve and grow the company. We strive to offer customers exceptional value through our qualified local sales and service representatives who provide convenient access to over 5,000 globally sourced products.

---

Depuis 1951 Omcan a grandi pour devenir un des “leaders” de la distribution des équipements et matériel pour l’industrie des services alimentaires en Amérique du Nord. Notre succès au cours de ces nombreuses années peut être attribué à notre engagement à renforcer et à développer de nouvelles et existantes relations avec nos clients et les fabricants de valeur. Aujourd’hui avec des partenaires en Amérique du Nord, Europe, Asie et Amérique du Sud, nous travaillons continuellement à améliorer et développer l’entreprise. Nous nous efforçons d’offrir à nos clients une valeur exceptionnelle grâce à nos ventes locales qualifiées et des représentants de service qui offrent un accès facile à plus de 5000 produits provenant du monde entier.

---

Desde 1951 Omcan ha crecido hasta convertirse en un líder en la distribución de equipos y suministros de alimentos en América del Norte industria de servicios. Nuestro éxito en estos años se puede atribuir a nuestro compromiso de fortalecer y desarrollar nuevas relaciones existentes con nuestros valiosos clientes y fabricantes. Hoy con socios de América del Norte, Europa, Asia y América del Sur, que trabajan continuamente para mejorar y crecer la empresa. Nos esforzamos por ofrecer a nuestros clientes valor excepcional a través de nuestro local de ventas y representantes de los servicios que proporcionan un fácil acceso a más de 5,000 productos con origen a nivel mundial.

