



Cheese Grater
Model GR-IT-1491-B
Item 19921
Instruction Manual



Revised - 09/25/2018

Toll Free: 1-800-465-0234
Fax: 905-607-0234
Email: service@omcan.com
www.omcan.com

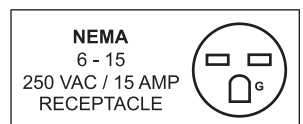

Table of Contents

Model GR-IT-1491-B

Section	Page
General Information -----	3 - 4
Safety and Warranty -----	4 - 6
Technical Specifications -----	6
Installation -----	6 - 7
Operation -----	7 - 9
Maintenance -----	9
Troubleshooting -----	9 - 10
Parts Breakdown -----	10 - 12
Electrical Schematics -----	13
Notes -----	14
Warranty Registration -----	15



General Information

Omcan Manufacturing and Distributing Company Inc., Food Machinery of America, Inc. dba Omcan and Omcan Inc. are not responsible for any harm or injury caused due to any person's improper or negligent use of this equipment. The product shall only be operated by someone over the age of 18, of sound mind, and not under the influence of any drugs or alcohol, who has been trained in the correct operation of this machine, and is wearing authorized, proper safety clothing. Any modification to the machine voids any warranty, and may cause harm to individuals using the machine or in the vicinity of the machine while in operation.

CHECK PACKAGE UPON ARRIVAL

Upon receipt of an Omcan shipment please inspect for external damage. If no damage is evident on the external packaging, open carton to ensure all ordered items are within the box, and there is no concealed damage to the machine. If the package has suffered rough handling, bumps or damage (visible or concealed), please note it on the bill of lading before accepting the delivery and contact Omcan within 24 hours, so we may initiate a claim with the carrier. A detailed report on the extent of the damage caused to the machine must be filled out within three days, from the delivery date shown in the shipping documents. Omcan has no recourse for damaged products that were shipped collect or third party.

Before operating any equipment, always read and familiarize yourself with all operation and safety instructions.

Omcan would like to thank you for purchasing this machine. It's of the utmost importance to save these instructions for future reference. Also save the original box and packaging for shipping the equipment if servicing or returning of the machine is required.

Omcan Fabrication et distribution Compañie Limité et Food Machinery d'Amérique, dba Omcan et Omcan Inc. ne sont pas responsables de tout dommage ou blessure causé du fait que toute personne ait utilisé cet équipement de façon irrégulière. Le produit ne doit être exploité que par quelqu'un de plus de 18 ans, saine d'esprit, et pas sous l'influence d'une drogue ou d'alcool, qui a été formé pour utiliser cette machine correctement, et est vêtu de vêtements de sécurité approprié. Toute modification de la machine annule toute garantie, et peut causer un préjudice à des personnes utilisant la machine ou des personnes à proximité de la machine pendant son fonctionnement.

VÉRIFIEZ LE COLIS DÈS RÉCEPTION

Dès réception d'une expédition d'Omcan veuillez inspecter pour dommages externes. Si aucun dommage n'est visible sur l'emballage externe, ouvrez le carton afin de s'assurer que tous les éléments commandés sont dans la boîte, et il n'y a aucun dommage dissimulé à la machine. Si le colis n'a subi aucune mauvaises manipulations, de bosses ou de dommages (visible ou cachée), notez-le sur le bond de livraison avant d'accepter la livraison et contactez Omcan dans les 24 heures qui suivent, pour que nous puissions engager une réclamation auprès du transporteur. Un rapport détaillé sur l'étendue des dommages causés à la machine doit être rempli dans un délai de trois jours, à compter de la date de livraison indiquée dans les documents d'expédition. Omcan n'a aucun droit de recours pour les produits endommagés qui ont été expédiés ou cueilli par un tiers transporteur.

General Information

Avant d'utiliser n'importe quel équipement, toujours lire et vous familiariser avec toutes les opérations et les consignes de sécurité.

Omcan voudrais vous remercier d'avoir choisi cette machine. Il est primordial de conserver ces instructions pour une référence ultérieure. Également conservez la boîte originale et l'emballage pour l'expédition de l'équipement si l'entretien ou le retour de la machine est nécessaire.

Omcan Empresa De Fabricacion Y Distribucion Inc. Y Maquinaria De Alimentos De America, Inc. dba Omcan y Omcan Inc. no son responsables de ningun daño o perjuicio causado por cualquier persona inadecuada o el uso descuidado de este equipo. El producto solo podra ser operado por una persona mayor de 18 años, en su sano juicio y no bajo alguna influencia de droga o alcohol, y que este ha sido entrenado en el correcto funcionamiento de esta máquina, y ésta usando ropa apropiada y autorizada. Cualquier modificación a la máquina anula la garantía y puede causar daños a las personas usando la máquina mientras esta en el funcionamiento.

REVISE EL PAQUETE A SU LLEGADA

Tras la recepcion de un envio Omcan favor inspeccionar daños externos. Si no hay daños evidentes en el empaque exterior, Habra el carton para asegurarse que todos los articulos solicitados estén dentro de la caja y no encuentre daños ocultos en la máquina. Si el paquete ha sufrido un manejo de poco cuidado, golpes o daños (visible o oculto) por favor anote en la factura antes de aceptar la entrega y contacte Omcan dentro de las 24 horas, de modo que podamos iniciar una reclamación con la compañía. Un informe detallado sobre los daños causados a la máquina debe ser llenado en el plazo de tres días, desde la fecha de entrega que se muestra en los documentos de envío. Omcan no tiene ningun recurso por productos dañados que se enviaron a recoger por terceros.

Antes de utilizar cualquier equipo, siempre lea y familiarizarse con todas las instrucciones de funcionamiento y seguridad.

Omcan le gustaría darle las gracias por la compra de esta máquina. Es de la mayor importancia para salvar estas instrucciones para futuras consultas. Además, guarda la caja original y el embalaje para el envío del equipo si servicio técnico o devolución de la máquina que se requiere.

Safety and Warranty

FORBIDDEN USES

The machine must only be used for the purposes expressly intended by the manufacturer. In particular:

- Do not use the machine to grate food products other than cheese, bread and the like.
- Do not use the machine if it has not been correctly installed with all the protections intact and correctly assembled to avoid the risk of severe injury.
- Do not access electrical components without having previously disconnected the machine: risk of

Safety and Warranty

electrocution.

- Do not work products that are bigger than what can be totally contained in the feeding inlet.
- Do not wear clothes that do not comply with safety regulations. Consult your employer for safety regulations and the safety devices required.
- Do not use the machine if it is not working correctly.

Before starting the machine make sure that any dangerous condition has been appropriately eliminated. If a fault occurs, stop the machine and notify persons in charge of maintenance.

- Do not allow unauthorized personnel to carry out work on the machine.

In the event of emergency treatment due to an accident caused by electrical shock, first remove the victim from the conductor (as he will be unconscious).

This operation is dangerous as the victim is a conductor in this case and touching him could cause electrocution.

Therefore disconnect the contact directly from the power supply valve or, if this is not possible, distance the victim using insulating material (wooden or pvc sticks, fabric, leather, etc.).

A doctor should be promptly called and the patient should be taken to the hospital.

ATTENTION!

Do not intervene on electrical parts while the machine is connected to the power supply.

Observe the warnings on the plates. Failure to observe them can cause serious injury.

Make sure the plates are always fitted and readable. If not, fit or replace them.

ATTENTION!

Before using the machine make sure that the devices are correctly positioned and in perfect working order.

At the beginning of each work shift check that they are fitted and working properly; if not, notify the head of maintenance.

MICROSWITCH ON THE LEVER

The machine is outfitted with a microswitch on the lever of the inlet. This works by blocking the machine when the lever remains lifted or the inlet is completely disassembled.

MICROSWITCH ON THE CONTAINER

The machine is outfitted with a microswitch on the plexiglass container. When the container is extracted the machine stops.

ATTENTION!

Do not tamper with the safety devices in any way.

1 YEAR PARTS AND LABOUR BENCH WARRANTY

Within the warranty period, contact Omcan Inc. at 1-800-465-0234 to schedule a drop off to either an Omcan authorized service depot in the area, or to an Omcan Service warehouse to repair the equipment.

Unauthorized maintenance will void the warranty. Warranty covers electrical and part failures, not

Safety and Warranty

improper use.

Please see www.omcan.com/warranty.html for complete info.

WARNING:

The packaging components are classified as normal solid urban waste and can therefore be disposed of without difficulty.

In any case, for suitable recycling, we suggest disposing of the products separately (differentiated waste) according to the current norms.

DO NOT DISCARD ANY PACKAGING MATERIALS IN THE ENVIRONMENT!

Technical Specifications

Model	GR-IT-1491-B
Power	2 HP / 1.5 kW
Grater Revolution	1400 RPM
Brake Motor	Yes
Mouth Dimensions	3.75" x 7.5 / 95 x 191mm
Electrical	220V / 60Hz / 1Ph
Weight	74 lbs. / 33.6 kg
Dimensions	20.8" x 13" x 20.5" / 528 x 330 x 518mm
Item Number	19921

Installation

ATTENTION!

The area where you intend to install the machine must be flat and solid. Furthermore, the machine must be positioned with ample space around it. This enables greater maneuverability during working phases and guarantees access for periodic maintenance. Ensure sufficient lighting around the machine to guarantee correct visibility for the machine operator.

Installation

MOVING THE MACHINE

ATTENTION!

Lift the machine with a forklift of suitable capacity. Check the stability and positioning of the weight on the forks, especially along uneven, slippery or inclined paths. When moving the machine keep the load as low as possible to guarantee greater stability and visibility. Stabilize the grip by widening the forks of the forklift.

CONNECTION TO THE ELECTRICAL SYSTEM

ATTENTION!

Make sure the electrical source corresponds to the value reported on the identification plate of the machine. Each operation should be carried out only by specialized personnel authorized by the appropriate supervisor. Connect the machine to a network with an efficient floor plug.

Connect the cable to the 230 V/50 Hz single-phase electrical supply network, inserting a 16-Amp magnetothermic differential switch. For machines with voltages different from those mentioned consult the manufacturer. If the feeding cable needs to be extended, use a cable with the same section as the one supplied by the manufacturer.

Operation

LIST OF COMMANDS

1. Stop pushbutton.
 - Stop pushbutton: black color.
 - Press to stop the machine.
 - The led on the pushbutton lights up only when the stop pushbutton is pressed (4).
2. Start pushbutton.
 - Start pushbutton: gray color.
 - Press to start the machine.
3. Lit indicator of connection to the mains.
 - White color.
 - It indicates the connection of the machine to the network.

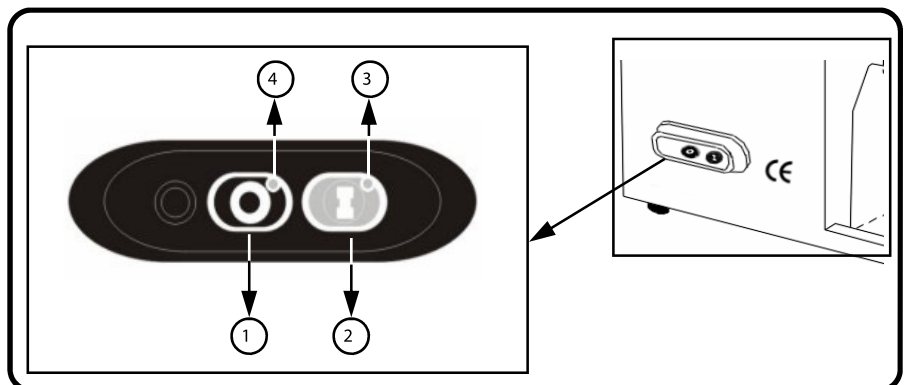

START UP AND STOP

ATTENTION!

Check that the feeding line corresponds to the value reported on the identification plate of the machine and

Operation

that it is outfitted with an efficient floor plug.

1. Put the plug into the electrical outlet.
2. Set the differential switch in position "I". The lit indicator, indicating that the machine is powered, must be illuminated.
3. Press the pushbutton to start and immediately afterwards press the stop one, checking the rotation direction of the roller.

NOTE

The presser must be in a low position.

The roller rotation direction must be the same as the one indicated by the arrow.

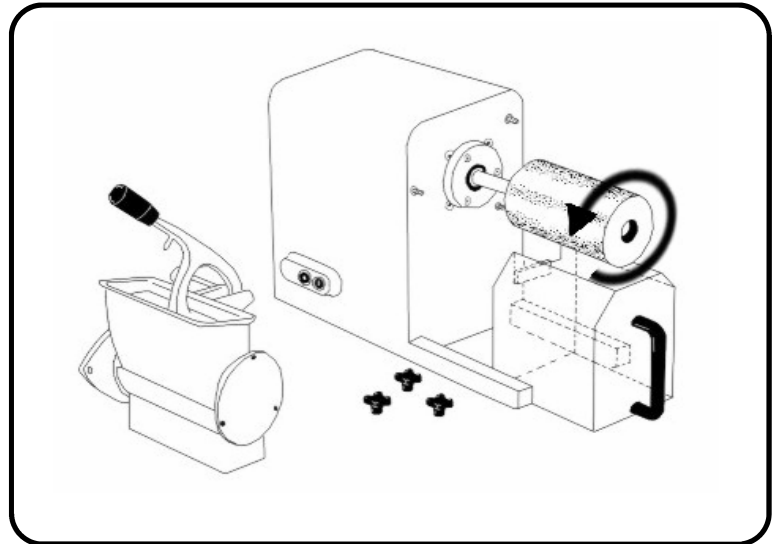

CHECKING THE PRESENCE AND EFFICIENCY OF PROTECTIONS AND SAFETIES

1. Microswitch on the lever.
While the machine is running lift the presser until the microswitch intervenes and stops the machine. Keep the presser still in the point in which the microswitch intervenes and check that the space between the loading inlet and the presser is such to block fingers from entering. If this is not the case contact an authorized reseller or the manufacturer.
2. Microswitch on the lever.
While the machine is running extract the plexiglass container and make sure that the machine stops.

CHECKING THE EFFICIENCY OF THE STOP PUSHBUTTON

While the machine is connected to the power supply and the utensil is moving press the pushbutton.

START UP

- Set the differential switch fitted upstream at "I". The light indicator will light up, indicating that the machine is powered.
- Press the start pushbutton to start the machine.

Note

If the presser is in an "open" position the machine will not run, therefore it will have to be lowered.

STOP

- Press the stop pushbutton to stop the running of the machine; the light indicator will remain on to indicate that the machine is powered.
- Then set the differential switch installed upstream at "0", in this way disconnecting the machine.

Note

Each time a work shift finishes or the machine is left to rest, the differential switch must be left set at

Operation

“0”.

USING THE SIEVE

The extractable sieve “1” in stainless steel enables obtaining a uniformly grated product, avoiding sieving. It must be requested upon ordering the machine.

Maintenance

ATTENTION!

Every maintenance and cleaning operation on the grater must only be done with the machine at a standstill, disconnected from the power supply. The area where maintenance operations are carried out must always be kept clean and dry. Do not allow unauthorized personnel to work on the machine. Any replacement of parts must be made with original spare parts at authorized work shops or directly by the manufacturer.

ATTENTION!

Disconnect the machine from the electrical supply before cleaning it. Do not clean the machine with jets of water. Only use non-toxic detergents, designated for cleaning components for use with food products.

PUTTING OUT OF ORDER

The machine is made of materials such as aluminum, steel and copper; therefore they do not require particular operations for scrapping. Therefore use companies specialized in trash disposal, separating the components according to material.

Troubleshooting

Problems	Causes	Solutions
The machine does not start.	The differential switch is not set at “0”.	Put the switch at “I”.
	The presser is in a high position.	Lower the presser.
	The microswitch installed on the grater inlet does not work.	Call technical assistance.
	The start pushbutton does not work.	
	The electrical motor or the electronic card are faulty.	

Troubleshooting

REFERENCE

Item Number	Model Number	Description	Manufacturer Model Number
19921	GR-IT-1491-B	Cheese Grater 2 HP / 1491 W with Motor Brake 220V/60/1	GFHP2/MB

Parts Breakdown

Model GR-IT-1491-B 19921

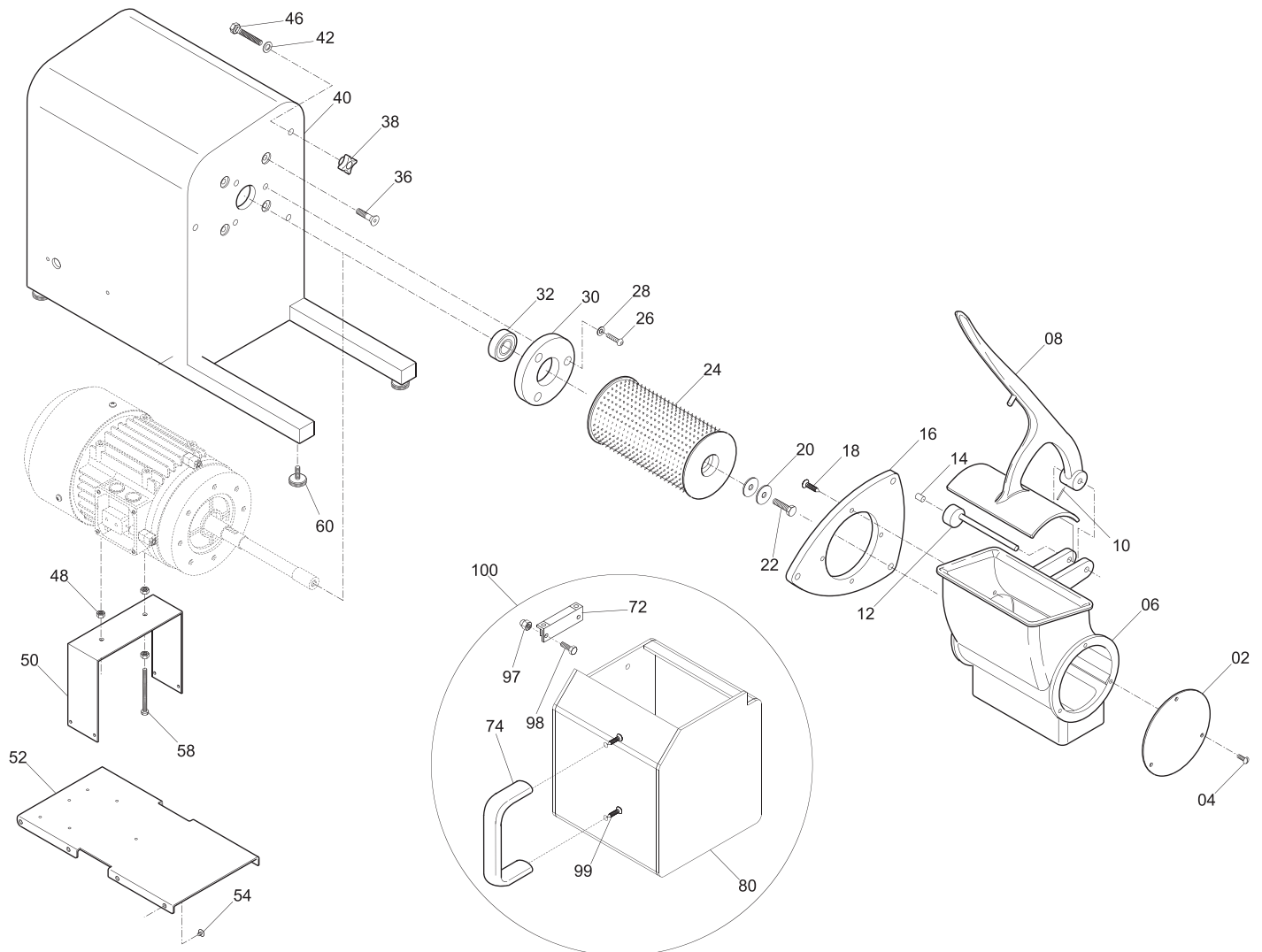

Parts Breakdown

Model GR-IT-1491-B 19921

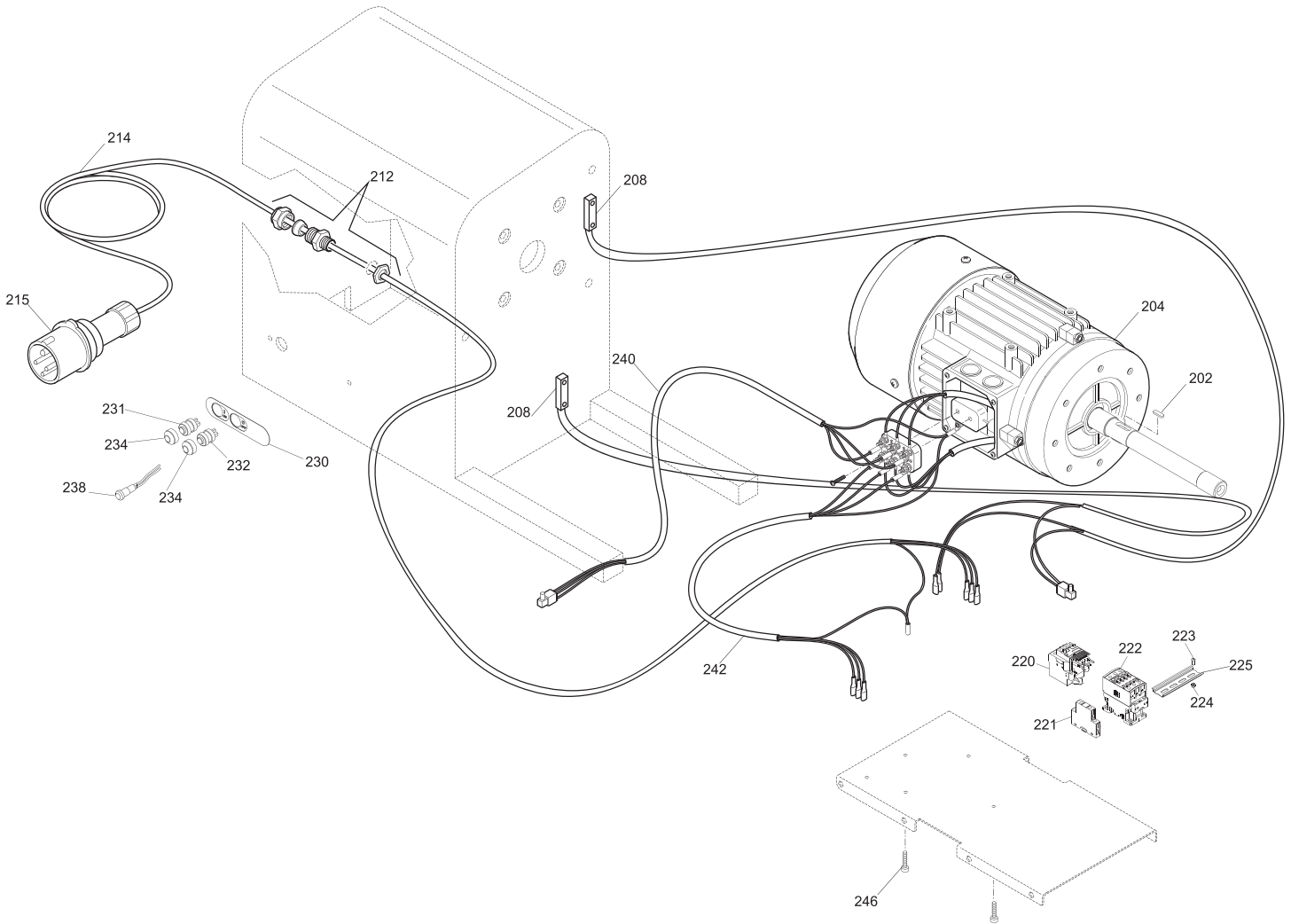

Parts Breakdown

Model GR-IT-1491-B 19921

Item No.	Description	Position	Item No.	Description	Position	Item No.	Description	Position
66622	Cover of Cheese Grater for GFHP2/MB	02	66628	Rubber Foot of Cheese Grater for GFHP2/MB	60	66632	Terminal Protection 13-16A ABB TF 42-16 for GFHP2/MB	220
66623	Grater Mouth Inox for GFHP2/MB	06	65421	Magnetic Switch for GFHP2/MB	72	39668	Contactora with Brake AUS LAT x AF 26-30-00-13 ABB for GFHP2/MB	221
44917	Handle for GFHP2/MB	08	66642	Handle for GFHP2/MB	74	39667	Remote Control Board with Brake AF 26-30-00-13 110/230 60Hz for GFHP2/MB	222
41688	Pin for GFHP2/MB	12	18959	Plexi Glass Collecting Tray for GFHP2/MB	80	66633	Screw Poeliers M4x12 for GFHP2/MB	223
18960	Magnet for SO Anodized/GF/FR for GFHP2/MB	14	60079	Self-Locking Nut ES DIN 982 M 5 High for GFHP2/MB	97	66634	Self-Locking Nut ES DIN 982 M 4 High for GFHP2/MB	224
60076	Flange Upper Mouth Grater GT HP 2 Inox for GFHP2/MB	16	60080	Screw Poeliers M5x12 for GFHP2/MB	98	66635	Guide DIN Omega H.7mm L= 50mm for GFHP2/MB	225
41907	Drum of Cheese Grater (Oct2014 - Current) for GFHP2/MB	24	60081	Screw Poeliers M6x10 for GFHP2/MB	99	66636	Label Push Button Panel Opera/IT for GFHP2/MB	230
66624	Flange of Cheese Grater for GFHP2/MB	30	60082	Receiving Tray Assembly for GFHP2/MB	100	41165	On Button Black for GFHP2/MB	231
66625	Bearing for GFHP2/MB	32	66629	Motor GTHP2 IX 110-60 ALB. Long S/ CARC for GFHP2/MB	204	41164	Off Button Red for GFHP2/MB	232
60077	Fixing Knob for GFHP2/MB	38	66630	Microswitch E531 TA 250VAC 3A for GFHP2/MB	208	66637	Gasket of Control Panel for GFHP2/MB	234
66626	Upper Motor Grater GT HP 2 Inox for GFHP2/MB	50	66631	Strain Relief OBO PG 11 for GFHP2/MB	212	37255	Pilot Lamp 220V for GFHP2/MB	238
66627	Grater Bottom Inox for GFHP2/MB	52	60087	Cee Plug 2P+T for GFHP2/MB	214 - 215			

Electrical Schematics

Model GR-IT-1491-B 19921

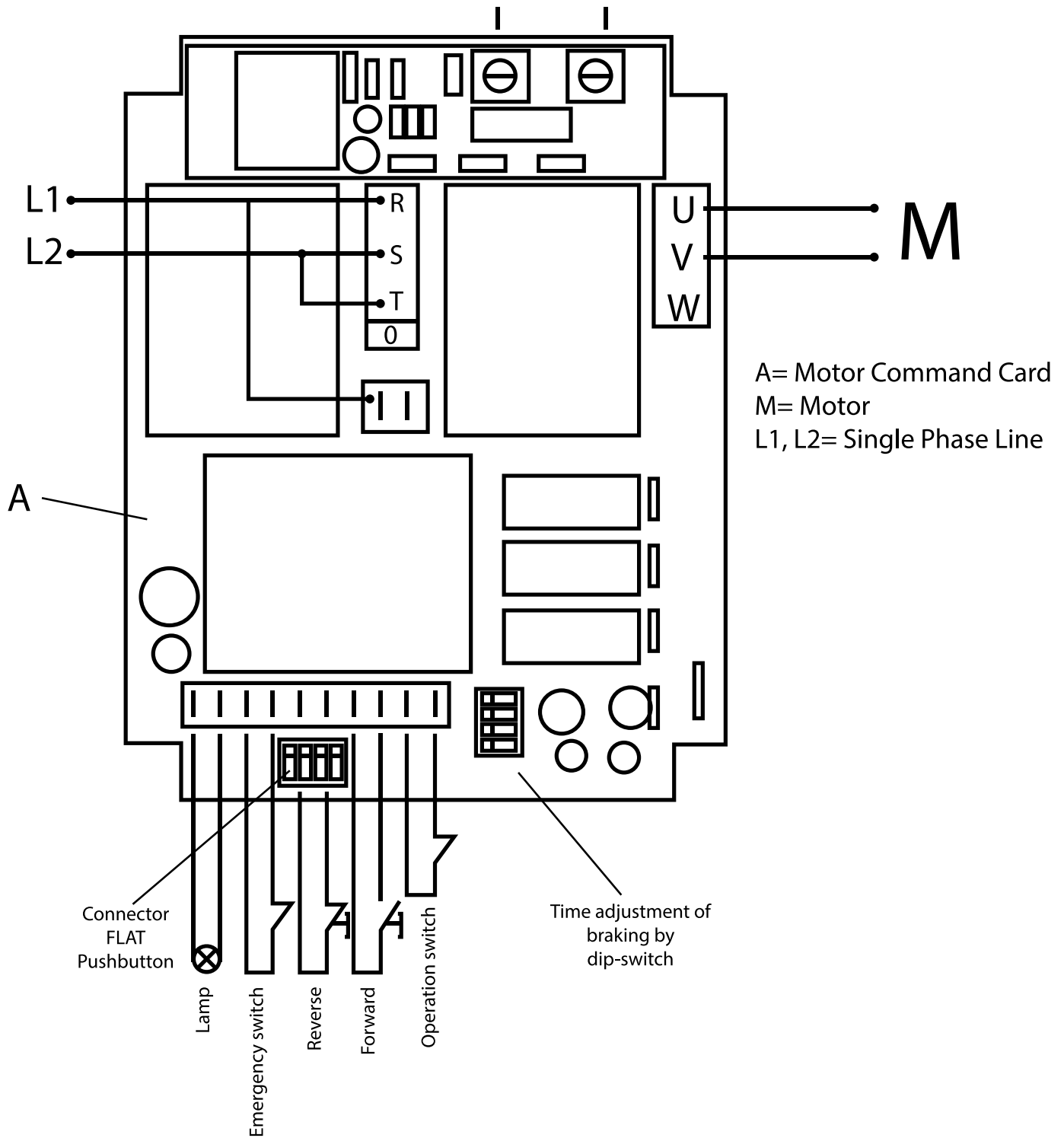



Warranty Registration

Thank you for purchasing an Omcan product. To register your warranty for this product, complete the information below, tear off the card at the perforation and then send to the address specified below. You can also register online by visiting:

Merci d'avoir acheté un produit Omcan. Pour enregistrer votre garantie pour ce produit, complétez les informations ci-dessous, détachez la carte au niveau de la perforation, puis l'envoyer à l'adresse spécifiée ci-dessous. Vous pouvez également vous inscrire en ligne en visitant:

Gracias por comprar un producto Omcan usted. Para registrar su garantía para este producto, complete la información a continuación, cortar la tarjeta en la perforación y luego enviarlo a la dirección indicada a continuación. También puede registrarse en línea en:

www.omcan.com/warrantyregistration.html

For mailing in Canada

Pour postale au Canada

Por correo en Canadá

OMCAN

PRODUCT WARRANTY REGISTRATION

3115 Pepper Mill Court,

Mississauga, Ontario

Canada, L5L 4X5

For mailing in the US

Pour diffusion aux États-Unis

Por correo en los EE.UU.

OMCAN

PRODUCT WARRANTY REGISTRATION

4450 Witmer Industrial Estates, Unit 4,

Niagara Falls, New York

USA, 14305

or email to: service@omcan.com



Purchaser's Information

Name: _____

Company Name: _____

Address: _____

Telephone: _____

City: _____ Province or State: _____ Postal or Zip: _____

Email Address: _____

Country: _____

Type of Company:

Restaurant Bakery Deli

Butcher Supermarket Caterer

Institution (*specify*): _____

Other (*specify*): _____

Dealer from which Purchased: _____

Dealer City: _____ Dealer Province or State: _____

Invoice: _____

Model Name: _____ Model Number: _____

Serial Number: _____

Machine Description: _____

Date of Purchase (MM/DD/YYYY): _____

Date of Installation (MM/DD/YYYY): _____

Would you like to extend the warranty? Yes No

Thank you for choosing Omcan | Merci d'avoir choisi Omcan | Gracias por elegir Omcan



Since 1951 Omcan has grown to become a leading distributor of equipment and supplies to the North American food service industry. Our success over these many years can be attributed to our commitment to strengthen and develop new and existing relationships with our valued customers and manufacturers. Today with partners in North America, Europe, Asia and South America, we continually work to improve and grow the company. We strive to offer customers exceptional value through our qualified local sales and service representatives who provide convenient access to over 5,000 globally sourced products.

Depuis 1951 Omcan a grandi pour devenir un des “leaders” de la distribution des équipements et matériel pour l’industrie des services alimentaires en Amérique du Nord. Notre succès au cours de ces nombreuses années peut être attribué à notre engagement à renforcer et à développer de nouvelles et existantes relations avec nos clients et les fabricants de valeur. Aujourd’hui avec des partenaires en Amérique du Nord, Europe, Asie et Amérique du Sud, nous travaillons continuellement à améliorer et développer l’entreprise. Nous nous efforçons d’offrir à nos clients une valeur exceptionnelle grâce à nos ventes locales qualifiées et des représentants de service qui offrent un accès facile à plus de 5000 produits provenant du monde entier.

Desde 1951 Omcan ha crecido hasta convertirse en un líder en la distribución de equipos y suministros de alimentos en América del Norte industria de servicios. Nuestro éxito en estos años se puede atribuir a nuestro compromiso de fortalecer y desarrollar nuevas relaciones existentes con nuestros valiosos clientes y fabricantes. Hoy con socios de América del Norte, Europa, Asia y América del Sur, que trabajan continuamente para mejorar y crecer la empresa. Nos esforzamos por ofrecer a nuestros clientes valor excepcional a través de nuestro local de ventas y representantes de los servicios que proporcionan un fácil acceso a más de 5,000 productos con origen a nivel mundial.

