



Orange Juicer
Model JE-CN-0020
Item 44228
Instruction Manual



Revised - 09/21/2018



Toll Free: 1-800-465-0234
Fax: 905-607-0234
Email: service@omcan.com
www.omcan.com

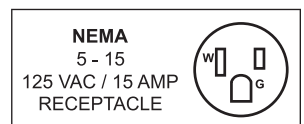

Table of Contents

Model JE-CN-0020

Section	Page
General Information -----	3 - 4
Safety and Warranty -----	4 - 5
Technical Specifications -----	5
Operation -----	5 - 7
Maintenance -----	7 - 10
Troubleshooting -----	10 - 11
Parts Breakdown -----	12 - 13
Electrical Schematics -----	14
Warranty Registration -----	15



General Information

Omcan Manufacturing and Distributing Company Inc., Food Machinery of America, Inc. dba Omcan and Omcan Inc. are not responsible for any harm or injury caused due to any person's improper or negligent use of this equipment. The product shall only be operated by someone over the age of 18, of sound mind, and not under the influence of any drugs or alcohol, who has been trained in the correct operation of this machine, and is wearing authorized, proper safety clothing. Any modification to the machine voids any warranty, and may cause harm to individuals using the machine or in the vicinity of the machine while in operation.

CHECK PACKAGE UPON ARRIVAL

Upon receipt of an Omcan shipment please inspect for external damage. If no damage is evident on the external packaging, open carton to ensure all ordered items are within the box, and there is no concealed damage to the machine. If the package has suffered rough handling, bumps or damage (visible or concealed), please note it on the bill of lading before accepting the delivery and contact Omcan within 24 hours, so we may initiate a claim with the carrier. A detailed report on the extent of the damage caused to the machine must be filled out within three days, from the delivery date shown in the shipping documents. Omcan has no recourse for damaged products that were shipped collect or third party.

Before operating any equipment, always read and familiarize yourself with all operation and safety instructions.

Omcan would like to thank you for purchasing this machine. It's of the utmost importance to save these instructions for future reference. Also save the original box and packaging for shipping the equipment if servicing or returning of the machine is required.

Omcan Fabrication et distribution Compañie Limité et Food Machinery d'Amérique, dba Omcan et Omcan Inc. ne sont pas responsables de tout dommage ou blessure causé du fait que toute personne ait utilisé cet équipement de façon irrégulière. Le produit ne doit être exploité que par quelqu'un de plus de 18 ans, saine d'esprit, et pas sous l'influence d'une drogue ou d'alcool, qui a été formé pour utiliser cette machine correctement, et est vêtu de vêtements de sécurité approprié. Toute modification de la machine annule toute garantie, et peut causer un préjudice à des personnes utilisant la machine ou des personnes à proximité de la machine pendant son fonctionnement.

VÉRIFIEZ LE COLIS DÈS RÉCEPTION

Dès réception d'une expédition d'Omcan veuillez inspecter pour dommages externes. Si aucun dommage n'est visible sur l'emballage externe, ouvrez le carton afin de s'assurer que tous les éléments commandés sont dans la boîte, et il n'y a aucun dommage dissimulé à la machine. Si le colis n'a subi aucune mauvaises manipulations, de bosses ou de dommages (visible ou cachée), notez-le sur le bond de livraison avant d'accepter la livraison et contactez Omcan dans les 24 heures qui suivent, pour que nous puissions engager une réclamation auprès du transporteur. Un rapport détaillé sur l'étendue des dommages causés à la machine doit être rempli dans un délai de trois jours, à compter de la date de livraison indiquée dans les documents d'expédition. Omcan n'a aucun droit de recours pour les produits endommagés qui ont été expédiés ou cueilli par un tiers transporteur.

General Information

Avant d'utiliser n'importe quel équipement, toujours lire et vous familiariser avec toutes les opérations et les consignes de sécurité.

Omcan voudrais vous remercier d'avoir choisi cette machine. Il est primordial de conserver ces instructions pour une référence ultérieure. Également conservez la boîte originale et l'emballage pour l'expédition de l'équipement si l'entretien ou le retour de la machine est nécessaire.

Omcan Empresa De Fabricacion Y Distribucion Inc. Y Maquinaria De Alimentos De America, Inc. dba Omcan y Omcan Inc. no son responsables de ningun daño o perjuicio causado por cualquier persona inadecuada o el uso descuidado de este equipo. El producto solo podra ser operado por una persona mayor de 18 años, en su sano juicio y no bajo alguna influencia de droga o alcohol, y que este ha sido entrenado en el correcto funcionamiento de esta máquina, y ésta usando ropa apropiada y autorizada. Cualquier modificación a la máquina anula la garantía y puede causar daños a las personas usando la máquina mientras esta en el funcionamiento.

REVISE EL PAQUETE A SU LLEGADA

Tras la recepcion de un envio Omcan favor inspeccionar daños externos. Si no hay daños evidentes en el empaque exterior, Habra el carton para asegurarse que todos los articulos solicitados estén dentro de la caja y no encuentre daños ocultos en la máquina. Si el paquete ha sufrido un manejo de poco cuidado, golpes o daños (visible o oculto) por favor anote en la factura antes de aceptar la entrega y contacte Omcan dentro de las 24 horas, de modo que podamos iniciar una reclamación con la compañía. Un informe detallado sobre los daños causados a la máquina debe ser llenado en el plazo de tres días, desde la fecha de entrega que se muestra en los documentos de envío. Omcan no tiene ningun recurso por productos dañados que se enviaron a recoger por terceros.

Antes de utilizar cualquier equipo, siempre lea y familiarizarse con todas las instrucciones de funcionamiento y seguridad.

Omcan le gustaría darle las gracias por la compra de esta máquina. Es de la mayor importancia para salvar estas instrucciones para futuras consultas. Además, guarda la caja original y el embalaje para el envío del equipo si servicio técnico o devolución de la máquina que se requiere.

Safety and Warranty

1 YEAR PARTS AND LABOUR BENCH WARRANTY

Within the warranty period, contact Omcan Inc. at 1-800-465-0234 to schedule a drop off to either an Omcan authorized service depot in the area, or to an Omcan Service warehouse to repair the equipment.

Unauthorized maintenance will void the warranty. Warranty covers electrical and part failures, not



Safety and Warranty

improper use.

Please see www.omcan.com/warranty.html for complete info.

WARNING:

The packaging components are classified as normal solid urban waste and can therefore be disposed of without difficulty.

In any case, for suitable recycling, we suggest disposing of the products separately (differentiated waste) according to the current norms.

DO NOT DISCARD ANY PACKAGING MATERIALS IN THE ENVIRONMENT!

Technical Specifications

Model	JE-CN-0020
Electrical	120V / 60Hz / 1Ph
Motor Power	120W
Power Consumption	300W
Size of Oranges	1.57" - 3.15" / 40mm - 80mm
Output	20 Oranges Per Minute
Dimensions	15.75" x 13" x 30.7" / 400 x 330 x 780mm
Packaging Dimensions	19.7" x 19.7" x 37.4" / 500 x 500 x 950mm
Weight	99.2 lbs. / 45 kgs.
Packaging Weight	110.2 lbs. / 50 kgs.
Item Number	44228

Operation

BEFORE OPERATION

1. The power supply must be safely grounded, and the machine connection parts shall only be changed by qualified individuals.
2. Check whether all parts are installed properly. This product is equipped with a safety system, only after the machine cover is correctly installed, it can work, the machine will not start otherwise.

Operation

3. Before using for the first time, please clean the unit thoroughly, taking extra care when cleaning the parts that come into contact with food.

OPERATION PROCESS

1. Put a glass or a desired container on the tray below the dispenser.

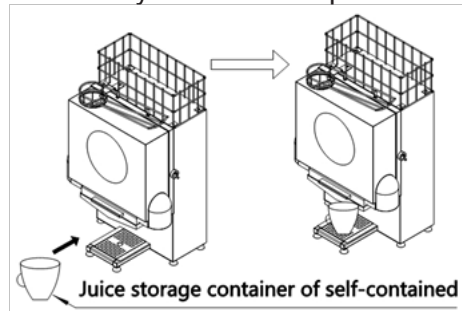

2. Put the fruit peel buckets under the two ejector slots on the sides of the unit.

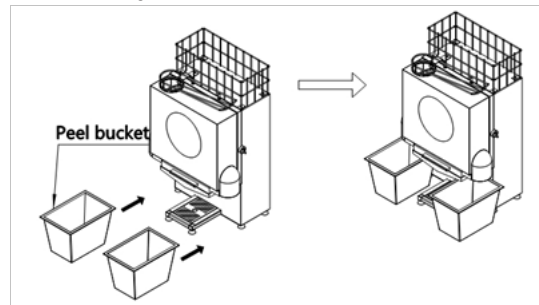

3. Fill the top basket with the desired amount of cleaned oranges.

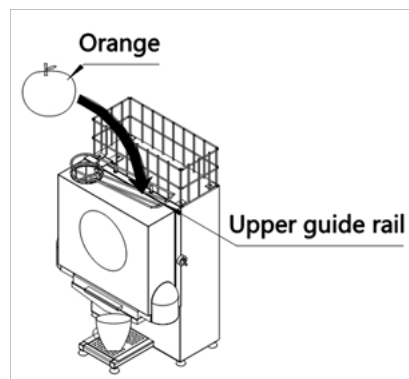

4. Plug in the machine and it will be ready to work.

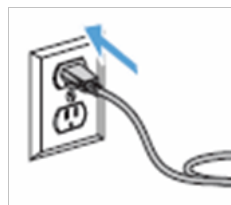

Operation

5. Pressing the start switch can feed the oranges continuously into the feeding port, once one orange has been squeezed the skin will be discarded into each peel basket automatically.

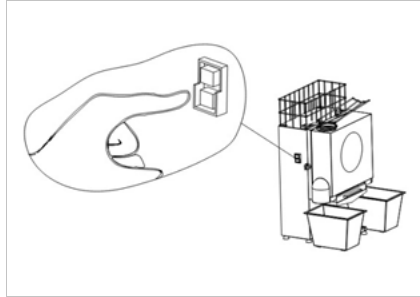

6. When the machine is operating, it is important to note that you must never insert your hands and fingers into the feeding port. If the juice storage container or the fruit peel bucket is filled up, switch off the power supply and then clean it.



7. After the operation of this machine is completed, turn off the unit and disconnect from the power supply.

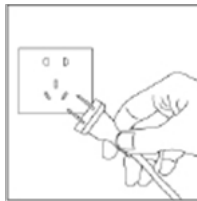

Maintenance

MAINTENANCE AND CLEANING

1. Before cleaning the product, the unit must be switched off, ensure to unplug the machine from the power source, always wait until the machine stops completely.
2. Clean the unit immediately after use.
3. The outer main body can be wiped with a damp cloth, do not wash the machine with water directly, remove

Maintenance

the parts that come into contact with the oranges and wash thoroughly.

4. Refer to the following steps on how to disassemble the parts to clean:
 - Unscrew the cover screw, remove the cover.

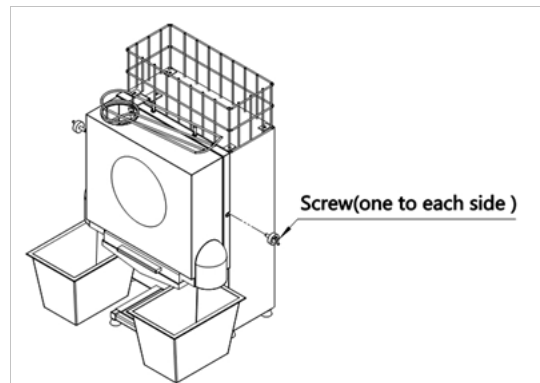

- Pull out the knife combination (being extra careful around the blade).

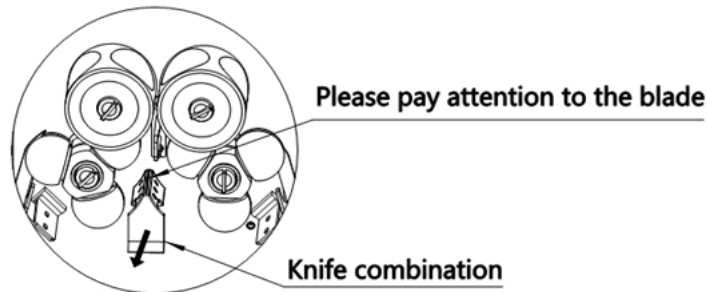

- Remove the two groups of scraper combinations by unscrewing the four screws and sliding them out as shown below.

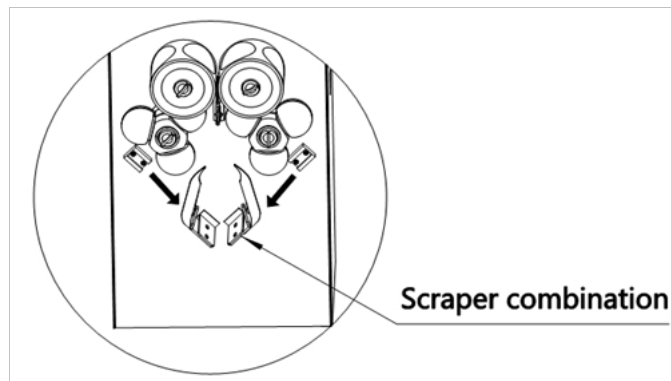

Maintenance

- Remove the two groups of concave and convex balls (each group of the concave and convex balls need to be removed at the same time).

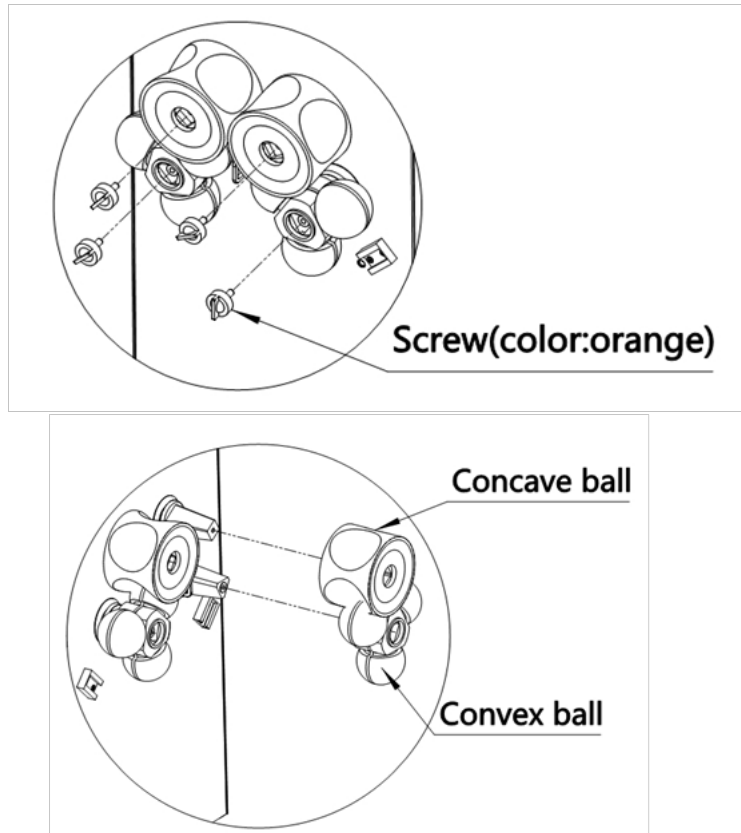

- After the cleaning of the unit is completed, re-install each part by following the previous instructions in the reverse order.

REPLACING THE GEARS

1. Remove the damaged cylindrical gear and the connected parts according to the assembly sequence.
2. Use two square hole templates to lock the upper two of four corner angle shaft parallels, and then install two big cylindrical gears.

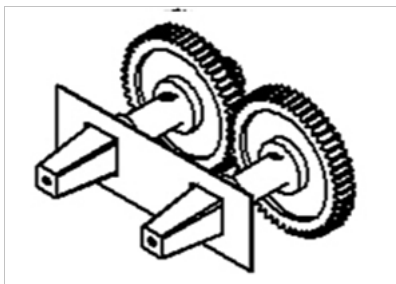

3. Remove the two square hole templates.

Maintenance

4. Use one square and a triangle template to lock the left (or right) upper four corner angle shaft and lower triangular shaft under the ridge axis, and then install the small cylindrical gear.



5. The installation method of the other side of the small cylindrical gear is the same as part 4.

Troubleshooting

Type of Fault	Problem	Check
Electrical fault.	The safety switch does not work.	Check whether the safety switch is in good condition.
		Check whether the safety switch is in the closed state.
	The starting switch does not work.	Check whether the starting switch is in good condition.
		Check whether the starting switch socket end is plugged.
	Motor does not work.	Check whether the socket at the two sides of the power line is tightened.
		Check whether the fuse is in good condition.
		Check whether the terminal in the motor switch box is solid connection.

Troubleshooting

Mechanical failure.	The motor output shaft end bevel gear wheel transmission mesh.	Check whether the size of bevel gear wheel is damaged.
		Check whether the meshing positions of the big and small bevel gears wheel are correct, the adjustable small bevel gears wheel is rising to the correct meshing position and tighten the hex screws on the gear(when the small bevel gear wheel on the motor shaft position is moved down).
	The damage of transmission cylindrical gear.	The size of transmission cylindrical gear is divided into a pair of large cylindrical gear (Z = 52), a pair of small cylindrical gear (Z = 39).
		Iron gear is generally is tooth form damage. If the cylindrical gear transmission has abnormal sound, it can be judged that the cylindrical gear is damaged, in the initial stage of the gear damaged, the machine work must be stopped immediately, the damaged gear must be replaced, otherwise it will affect the relative position of the working parts of machine, thus aggravates the damage of the gear, and until damage the electrical machine and the working surface of the and concave and convex balls.

REFERENCE

Item Number	Model Number	Description	Manufacturer Model Number
44228	JE-CN-0020	Juice Extractor 20 Orange per Min 120W 115V/60/1 cETLus	2000E-2

Parts Breakdown

Model JE-CN-0020 44228

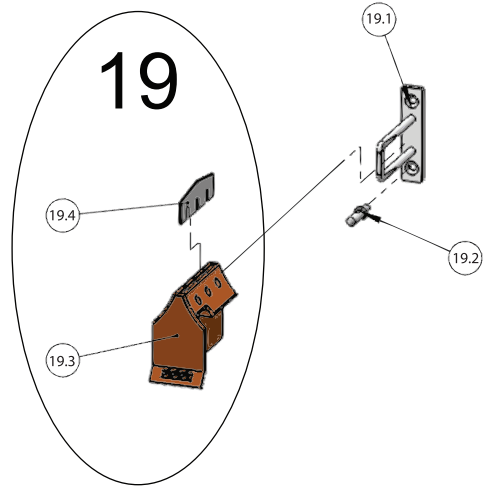
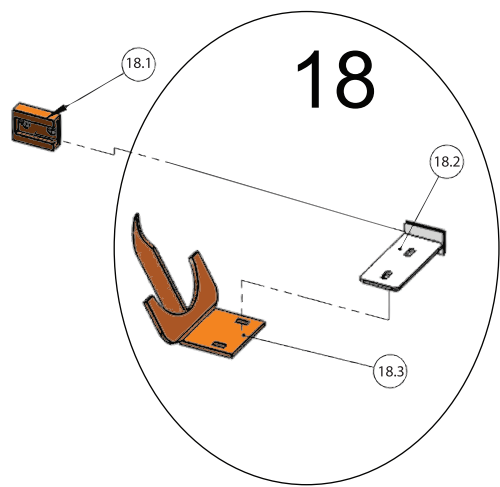
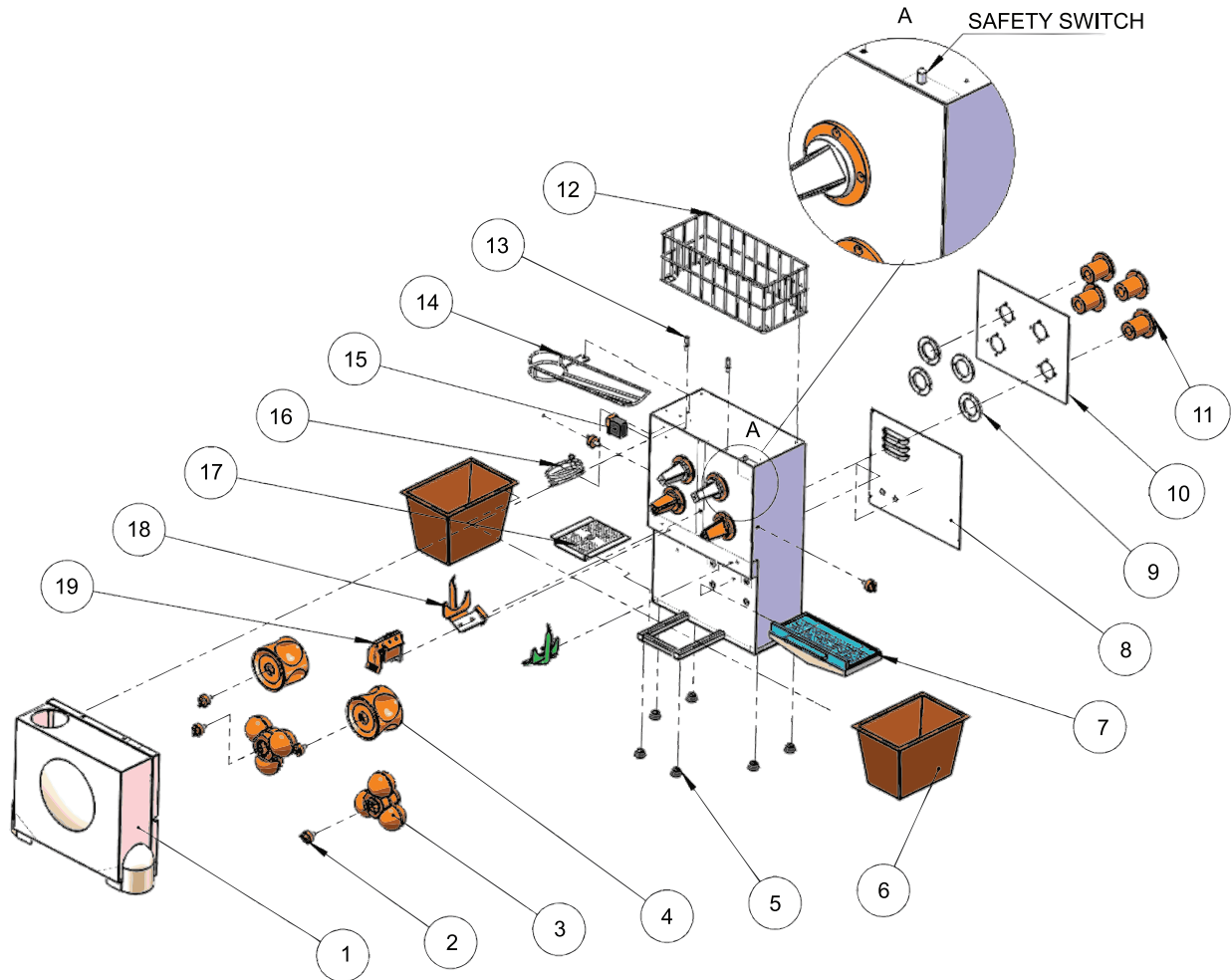

Parts Breakdown

Model JE-CN-0020 44228

Item No.	Description	Position	Item No.	Description	Position	Item No.	Description	Position
65914	Cover for 2000E-2	1	65918	Panel in Back for 2000E-2	10	65907	Peeler Stand for 2000E-2	18.1
65909	Screw for 2000E-2	2	65929	Back Axle Protection for 2000E-2	11	65906	Peeler Shelf for 2000E-2	18.2
65910	Convex Ball for 2000E-2	3	65900	Basket for 2000E-2	12	65905	Peeler for 2000E-2	18.3
65908	Concave Ball for 2000E-2	4	66055	Fix Lock for 2000E-2	13	66057	Complete Blade Set for 2000E-2	19
65917	Feet Screw for 2000E-2	5	65901	Slide Way for 2000E-2	14	65913	Blade Shelf (Stainless) for 2000E-2	19.1
65932	Plastic Bucket (Two) for 2000E-2	6	65916	Starting Switch for 2000E-2	15	66058	Screw for Blade Shelf for 2000E-2	19.2
65898	Leaking Drawer for 2000E-2	7	65904	Slide Way for 2000E-2	16	65911	Blade Stand for 2000E-2	19.3
65899	Juicer Holder for 2000E-2	7	65902	Tray for 2000E-2	17	65912	Blade (Stainless) for 2000E-2	19.4
65896	Back Over Plank for 2000E-2	8	65903	Tray Bottom for 2000E-2	17	65925	Safety Switch for 2000E-2	A
65923	Gear Protection for 2000E-2	9	66056	Complete Peeler Set for 2000E-2	18			

Electrical Schematics

Model JE-CN-0020 44228

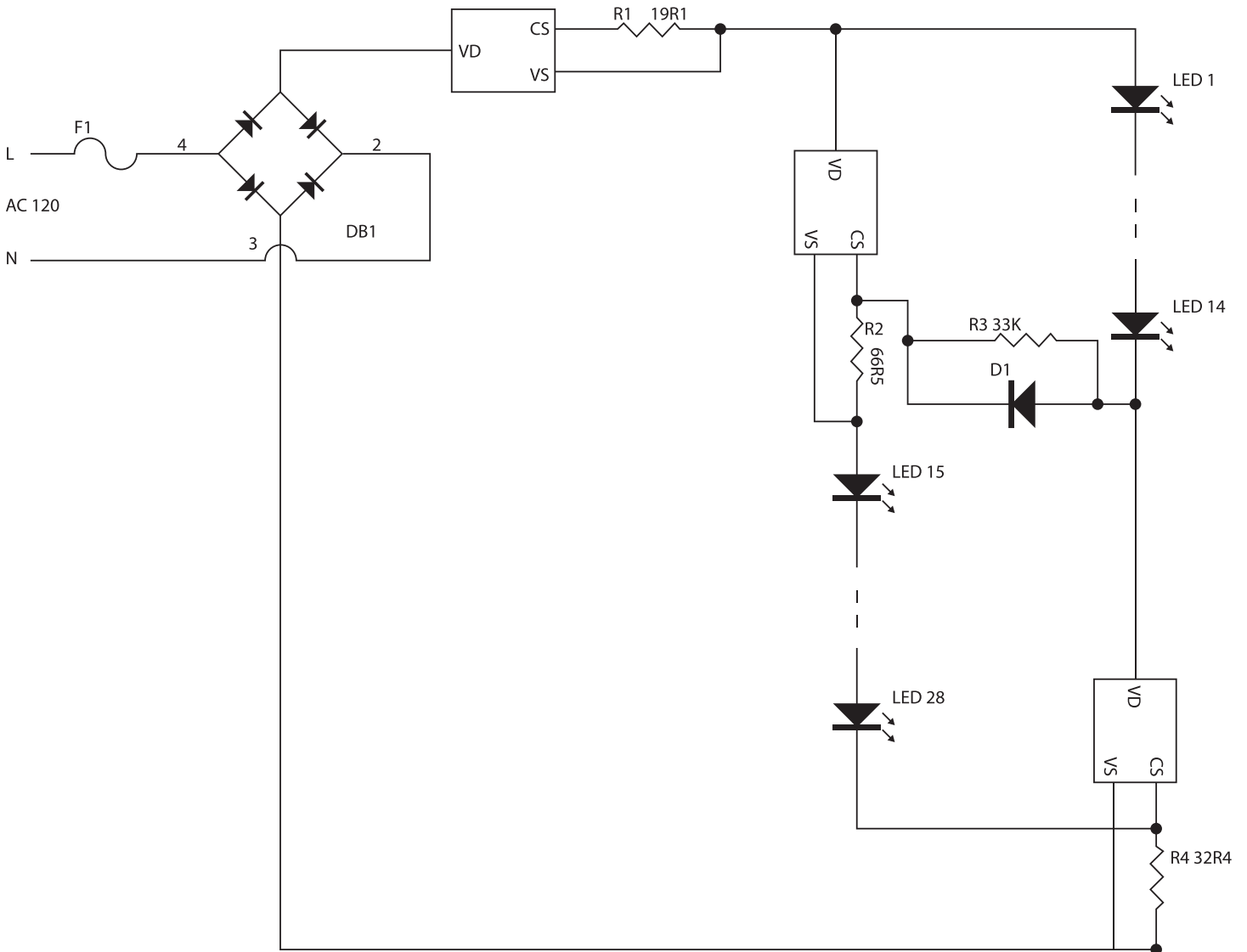



Warranty Registration

Thank you for purchasing an Omcan product. To register your warranty for this product, complete the information below, tear off the card at the perforation and then send to the address specified below. You can also register online by visiting:

Merci d'avoir acheté un produit Omcan. Pour enregistrer votre garantie pour ce produit, complétez les informations ci-dessous, détachez la carte au niveau de la perforation, puis l'envoyer à l'adresse spécifiée ci-dessous. Vous pouvez également vous inscrire en ligne en visitant:

Gracias por comprar un producto Omcan usted. Para registrar su garantía para este producto, complete la información a continuación, cortar la tarjeta en la perforación y luego enviarlo a la dirección indicada a continuación. También puede registrarse en línea en:

www.omcan.com/warrantyregistration.html

For mailing in Canada

Pour postale au Canada

Por correo en Canadá

OMCAN

PRODUCT WARRANTY REGISTRATION

3115 Pepper Mill Court,

Mississauga, Ontario

Canada, L5L 4X5

For mailing in the US

Pour diffusion aux États-Unis

Por correo en los EE.UU.

OMCAN

PRODUCT WARRANTY REGISTRATION

4450 Witmer Industrial Estates, Unit 4,

Niagara Falls, New York

USA, 14305

or email to: service@omcan.com



Purchaser's Information

Name: _____

Address: _____

City: _____ Province or State: _____ Postal or Zip: _____

Country: _____

Dealer from which Purchased: _____

Dealer City: _____ Dealer Province or State: _____

Invoice: _____

Model Name: _____ Model Number: _____

Machine Description: _____

Date of Purchase (MM/DD/YYYY): _____

Would you like to extend the warranty? Yes No

Company Name: _____

Telephone: _____

Email Address: _____

Type of Company:

Restaurant Bakery Deli

Butcher Supermarket Caterer

Institution (*specify*): _____

Other (*specify*): _____

Serial Number: _____

Date of Installation (MM/DD/YYYY): _____

Thank you for choosing Omcan | Merci d'avoir choisi Omcan | Gracias por elegir Omcan



Since 1951 Omcan has grown to become a leading distributor of equipment and supplies to the North American food service industry. Our success over these many years can be attributed to our commitment to strengthen and develop new and existing relationships with our valued customers and manufacturers. Today with partners in North America, Europe, Asia and South America, we continually work to improve and grow the company. We strive to offer customers exceptional value through our qualified local sales and service representatives who provide convenient access to over 5,000 globally sourced products.

Depuis 1951 Omcan a grandi pour devenir un des “leaders” de la distribution des équipements et matériel pour l’industrie des services alimentaires en Amérique du Nord. Notre succès au cours de ces nombreuses années peut être attribué à notre engagement à renforcer et à développer de nouvelles et existantes relations avec nos clients et les fabricants de valeur. Aujourd’hui avec des partenaires en Amérique du Nord, Europe, Asie et Amérique du Sud, nous travaillons continuellement à améliorer et développer l’entreprise. Nous nous efforçons d’offrir à nos clients une valeur exceptionnelle grâce à nos ventes locales qualifiées et des représentants de service qui offrent un accès facile à plus de 5000 produits provenant du monde entier.

Desde 1951 Omcan ha crecido hasta convertirse en un líder en la distribución de equipos y suministros de alimentos en América del Norte industria de servicios. Nuestro éxito en estos años se puede atribuir a nuestro compromiso de fortalecer y desarrollar nuevas relaciones existentes con nuestros valiosos clientes y fabricantes. Hoy con socios de América del Norte, Europa, Asia y América del Sur, que trabajan continuamente para mejorar y crecer la empresa. Nos esforzamos por ofrecer a nuestros clientes valor excepcional a través de nuestro local de ventas y representantes de los servicios que proporcionan un fácil acceso a más de 5,000 productos con origen a nivel mundial.

