



Meat Grinders
Models MG-CN-0012-S, 0022-S
Items 23580, 23626
Instruction Manual



STOP
DO NOT RETURN
THIS PRODUCT TO THE STORE

For questions or assistance with this product call OMCAN Toll Free:
1 800 465 0234
Customer Service
or
visit the Support section of
www.omcan.com

Revised - 04/16/2019



Toll Free: 1-800-465-0234
Fax: 905-607-0234
Email: service@omcan.com
www.omcan.com

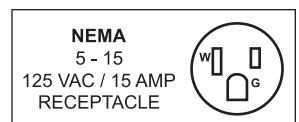

Table of Contents

Model MG-CN-0012-S / Model MG-CN-0022-S

Section	Page
General Information -----	3 - 4
Safety and Warranty -----	4 - 6
Technical Specifications -----	6
Assembly and Operation -----	6 - 7
Maintenance and Cleaning -----	7 - 8
Parts Breakdown -----	9 - 11
Electrical Schematics -----	12
Notes -----	13 - 14
Warranty Registration -----	15



General Information

Omcan Manufacturing and Distributing Company Inc., Food Machinery of America, Inc. dba Omcan and Omcan Inc. are not responsible for any harm or injury caused due to any person's improper or negligent use of this equipment. The product shall only be operated by someone over the age of 18, of sound mind, and not under the influence of any drugs or alcohol, who has been trained in the correct operation of this machine, and is wearing authorized, proper safety clothing. Any modification to the machine voids any warranty, and may cause harm to individuals using the machine or in the vicinity of the machine while in operation.

CHECK PACKAGE UPON ARRIVAL

Upon receipt of an Omcan shipment please inspect for external damage. If no damage is evident on the external packaging, open carton to ensure all ordered items are within the box, and there is no concealed damage to the machine. If the package has suffered rough handling, bumps or damage (visible or concealed), please note it on the bill of lading before accepting the delivery and contact Omcan within 24 hours, so we may initiate a claim with the carrier. A detailed report on the extent of the damage caused to the machine must be filled out within three days, from the delivery date shown in the shipping documents. Omcan has no recourse for damaged products that were shipped collect or third party.

Before operating any equipment, always read and familiarize yourself with all operation and safety instructions.

Omcan would like to thank you for purchasing this machine. It's of the utmost importance to save these instructions for future reference. Also save the original box and packaging for shipping the equipment if servicing or returning of the machine is required.

Omcan Fabrication et distribution Compañie Limité et Food Machinery d'Amerique, dba Omcan et Omcan Inc. ne sont pas responsables de tout dommage ou blessure causé du fait que toute personne ait utilisé cet équipement de façon irrégulière. Le produit ne doit être exploité que par quelqu'un de plus de 18 ans, saine d'esprit, et pas sous l'influence d'une drogue ou d'acohol, qui a été formé pour utiliser cette machine correctement, et est vêtu de vêtements de sécurité approprié. Toute modification de la machine annule toute garantie, et peut causer un préjudice à des personnes utilisant la machine ou des personnes à proximité de la machine pendant son fonctionnement.

VÉRIFIEZ LE COLIS DÈS RÉCEPTION

Dès réception d'une expédition d'Omcan veuillez inspecter pour dommages externes. Si aucun dommage n'est visible sur l'emballage externe, ouvrez le carton afin de s'assurer que tous les éléments commandés sont dans la boîte, et il n'y a aucun dommage dissimulé à la machine. Si le colis n'a subi aucune mauvaises manipulations, de bosses ou de dommages (visible ou cachée), notez-le sur le bond de livraison avant d'accepter la livraison et contactez Omcan dans les 24 heures qui suivent, pour que nous puissions engager une réclamation auprès du transporteur. Un rapport détaillé sur l'étendue des dommages causés à la machine doit être rempli dans un délai de trois jours, à compter de la date de livraison indiquée dans les documents d'expédition. Omcan n'a aucun droit de recours pour les produits endommagés qui ont été expédiées ou cueilli par un tiers transporteur.

General Information

Avant d'utiliser n'importe quel équipement, toujours lire et vous familiariser avec toutes les opérations et les consignes de sécurité.

Omcan voudrais vous remercier d'avoir choisi cette machine. Il est primordial de conserver ces instructions pour une référence ultérieure. Également conservez la boîte originale et l'emballage pour l'expédition de l'équipement si l'entretien ou le retour de la machine est nécessaire.

Omcan Empresa De Fabricacion Y Distribucion Inc. Y Maquinaria De Alimentos De America, Inc. dba Omcan y Omcan Inc. no son responsables de ningun daño o perjuicio causado por cualquier persona inadecuada o el uso descuidado de este equipo. El producto solo podra ser operado por una persona mayor de 18 años, en su sano juicio y no bajo alguna influencia de droga o alcohol, y que este ha sido entrenado en el correcto funcionamiento de esta máquina, y ésta usando ropa apropiada y autorizada. Cualquier modificación a la máquina anula la garantía y puede causar daños a las personas usando la máquina mientras esta en el funcionamiento.

REVISE EL PAQUETE A SU LLEGADA

Tras la recepcion de un envio Omcan favor inspeccionar daños externos. Si no hay daños evidentes en el empaque exterior, Habra el carton para asegurarse que todos los articulos solicitados estén dentro de la caja y no encuentre daños ocultos en la máquina. Si el paquete ha sufrido un manejo de poco cuidado, golpes o daños (visible o oculto) por favor anote en la factura antes de aceptar la entrega y contacte Omcan dentro de las 24 horas, de modo que podamos iniciar una reclamación con la compañía. Un informe detallado sobre los daños causados a la máquina debe ser llenado en el plazo de tres días, desde la fecha de entrega que se muestra en los documentos de envío. Omcan no tiene ningun recurso por productos dañados que se enviaron a recoger por terceros.

Antes de utilizar cualquier equipo, siempre leer y familiarizarse con todas las instrucciones de operación y seguridad.

Omcan quisiera darles las gracias por la compra de esta máquina. Es de la máxima importancia para guardar estas instrucciones para referencias en el futuro. También guarde la caja original y el embalaje para envío del equipo si el mantenimiento o la devolución de la máquina es necesaria.

Safety and Warranty

IMPORTANT SAFEGUARDS

When using any electrical appliances, basic safety precautions should always be followed including the following:

- Read all instructions.
- To protect against risk of electrical shock do not put meat grinder in water or other liquid.

Safety and Warranty

- Close supervision is necessary when any appliance is used near children.
- Unplug from outlet when not in use, before putting on or taking off parts, and before cleaning.
- Avoid contacting moving parts. Never feed meat by hand. Always use the pusher.
- Do not operate any appliance with a damaged cord or plug or after the appliance malfunctions, or is dropped or damaged in any manner. Return appliance to the Omcan service facility for examination, repair or electrical or mechanical adjustment.
- The use of attachments not recommended or sold by Omcan may cause fire, electric shock or injury.
- Do not use outdoors.
- Do not let cord hang over edge of table or counter.
- Do not let cord contact hot surface, including the stove.
- Do not use fingers to scrape food away from discharge disc while appliance is operating.
- Do not use hands to push product into the machine throat while machine is in operation.
- SAVE THESE INSTRUCTIONS.

CAUTION

- When carrying the unit, be sure to hold Motor Housing with both hands, do not hold only Hopper Plate. Be careful to carry the unit, as it is very heavy.
- Do not grind hard foods such as bones, frozen meat, nuts, or vegetables.
- Do not grind ginger and other materials with hard fiber.
- To avoid jamming, do not force to operate the unit with excessive pressure.
- If the unit jams, switch off immediately and clean the unit. (See “Jamming”)
- Always connect your device to a grounded electrical outlet.
- Do not unplug the appliance by pulling on cord. To unplug, grasp the plug not the cord.
- The appliance should be used strictly in accordance with these instructions as no liability can be accepted for any damage caused by non-compliance with these instructions, or any other improper or handling.

DISCLAIMER

PLEASE RUN THE UNIT WITH A LIGHT, DISPOSABLE LOAD TO REMOVE ANY METAL SHAVINGS FROM THE MACHINE BEFORE FIRST USE!

1 YEAR PARTS AND LABOUR BENCH WARRANTY

Within the warranty period, contact Omcan Inc. at 1-800-465-0234 to schedule a drop off to either an Omcan authorized service depot in the area, or to an Omcan Service warehouse to repair the equipment.

Unauthorized maintenance will void the warranty. Warranty covers electrical and part failures, not improper use.

Please see <https://omcan.com/disclaimer> for complete info.

Safety and Warranty

WARNING:

The packaging components are classified as normal solid urban waste and can therefore be disposed of without difficulty.

In any case, for suitable recycling, we suggest disposing of the products separately (differentiated waste) according to the current norms.

DO NOT DISCARD ANY PACKAGING MATERIALS IN THE ENVIRONMENT!

Technical Specifications

Model	MG-CN-0012-S	MG-CN-0022-S
Peak Power	650 Watts / 0.87 HP	1100 Watts / 1.5 HP
Throat Opening	2.25" / 57mm	
Capacity	260 lbs. /hr.	485 lbs. /hr.
RPM	150	175
Electrical	110V/60/1	
Weight	59 lbs. / 26.8 kgs.	80 lbs. / 36.3 kgs.
Packaging Weight	64 lbs. / 29 kgs.	96 lbs. / 43.5 kgs.
Dimensions	17.6" x 7.6" x 13.4" 448 x 194 x 340mm	22.5" x 9" x 16.3" 572 x 229 x 413mm
Packaging Dimensions	19" x 13" x 17" 483 x 330 x 432mm	24" x 14" x 19" 610 x 356 x 483mm
Item Number	23580	23626

BEFORE USE

Make sure that the voltage and frequency indicated on the rated plate are the same as your local supply, and that the mains are properly ground. Wash all the parts (except those that do not touch meat) in warm soapy water. Before plugging in, ensure switch is off and unit is thoroughly dry.

Assembly and Operation

TO MINCE / GRIND MEAT

Assembling

1. Place auger tube tightly onto opening of motor housing.

Assembly and Operation

2. Holding tube with one hand, tighten locking knob clockwise.
3. Place auger into the tube, long end first, by turning auger slightly until it is set into motor housing and cover the transmission shaft.
4. Place cutting blade onto auger with the blade facing the front as illustrated.
 - If it is not fitted properly, meat will not be ground.
5. Place the desired cutting plate next to cutting blade, and align the pin with the plate.
6. Screw the locking ring onto the auger tube.
7. Do not over tighten. Place hopper plate on head and fix into position.
8. Position the unit on a firm surface.
 - The air passage at the bottom and the side of motor housing should be kept free and not blocked, maintain a minimum of 4"/10cm free space around the grinder.

Mincing / Grinding meat

Cut all boneless meat into pieces so that they fit easily into hopper opening. Plug in, then switch the machine on.

1. Use the pusher to feed the meat into the grinder.
 - After use, switch off and unplug.

TROUBLE SHOOTING:

If the minced meat is not discharged smoothly or in the form of paste, the causes and remedies could be:

- Screw cap is tightened too much thus, the cutting blade does not contact properly with the cutting plate. Readjust it.
- The cutting plate is blocked. Clean it.
- Cutting blade edges is dull. Sharpen or replace it.

JAMMING

When the circuit breaker automatically stops the motor, or when the motor continues to function but no meat comes out of cutting plate, due to jamming, switch off.

- Do not switch on. Press CIRCUIT BREAKER to reset. Turn switch to REVERSE to clear the jam.
- Reverse operation will continue for as long as REVERSE is held. Clean the unit.

Maintenance and Cleaning

ALWAYS UNPLUG THE MACHINE FROM THE ELECTRICAL SOCKET BEFORE PERFORMING ANY MAINTENANCE OR CLEANING!

TO CLEAN

Disassembling

Make sure that the motor has stopped completely. Disconnect the plug from the power outlet.

Maintenance and Cleaning

Locking ring has 3 flat sides, convenient for unscrewing. If locking ring is too tight, please knock at the flat sides with a soft-handle, then locking ring will be unscrewed easily.

Unscrew the locking knob, and take out the auger tube (with cutting plate, cutting blade and feed screw), then point the auger tube mouth downward in order to take out cutting plate, cutting blade and feed screw.

Cleaning

Remove meat, etc. wash each part in warm soapy water.

- A bleaching solution containing chlorine will discolor aluminum surfaces.
- Do not immerse motor housing in water, but only wipe it with a damp cloth.

A little salad oil on the plate & knife after washing and drying will keep them lubricated.

REFERENCE

Item Number	Model Number	Description	Manufacturer Model Number
23580	MG-CN-0012-S	Meat Grinder #12 Stainless Steel 0.9 HP / 649 W 110V/60/1 cETLus	BSM12
23626	MG-CN-0022-S	Meat Grinder #22 Stainless Steel 1.5 HP / 1119 W 110V/60/1 cETLus	BSM22

Parts Breakdown

Model MG-CN-0012-S 23580

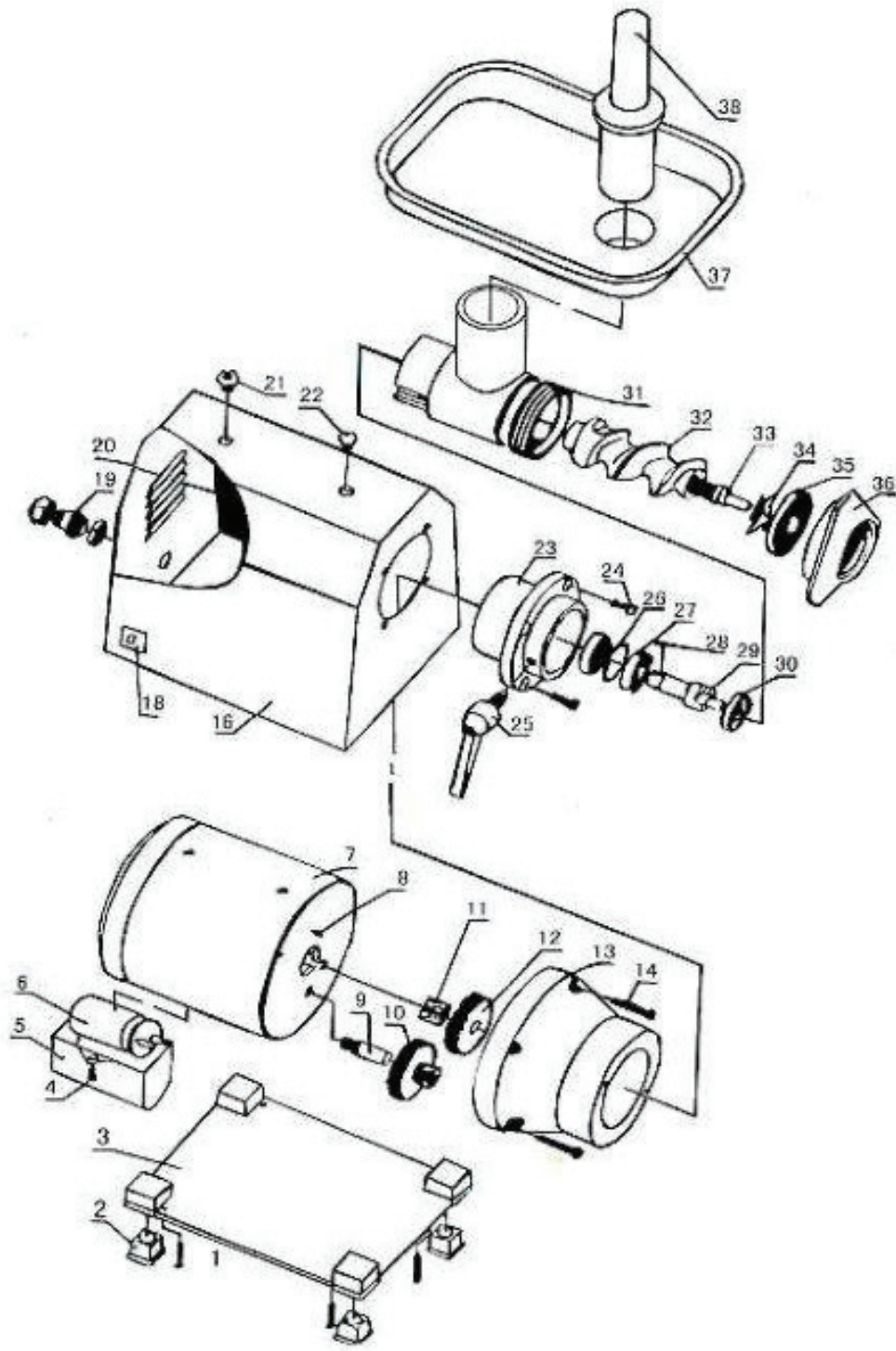

Parts Breakdown

Model MG-CN-0022-S 23626

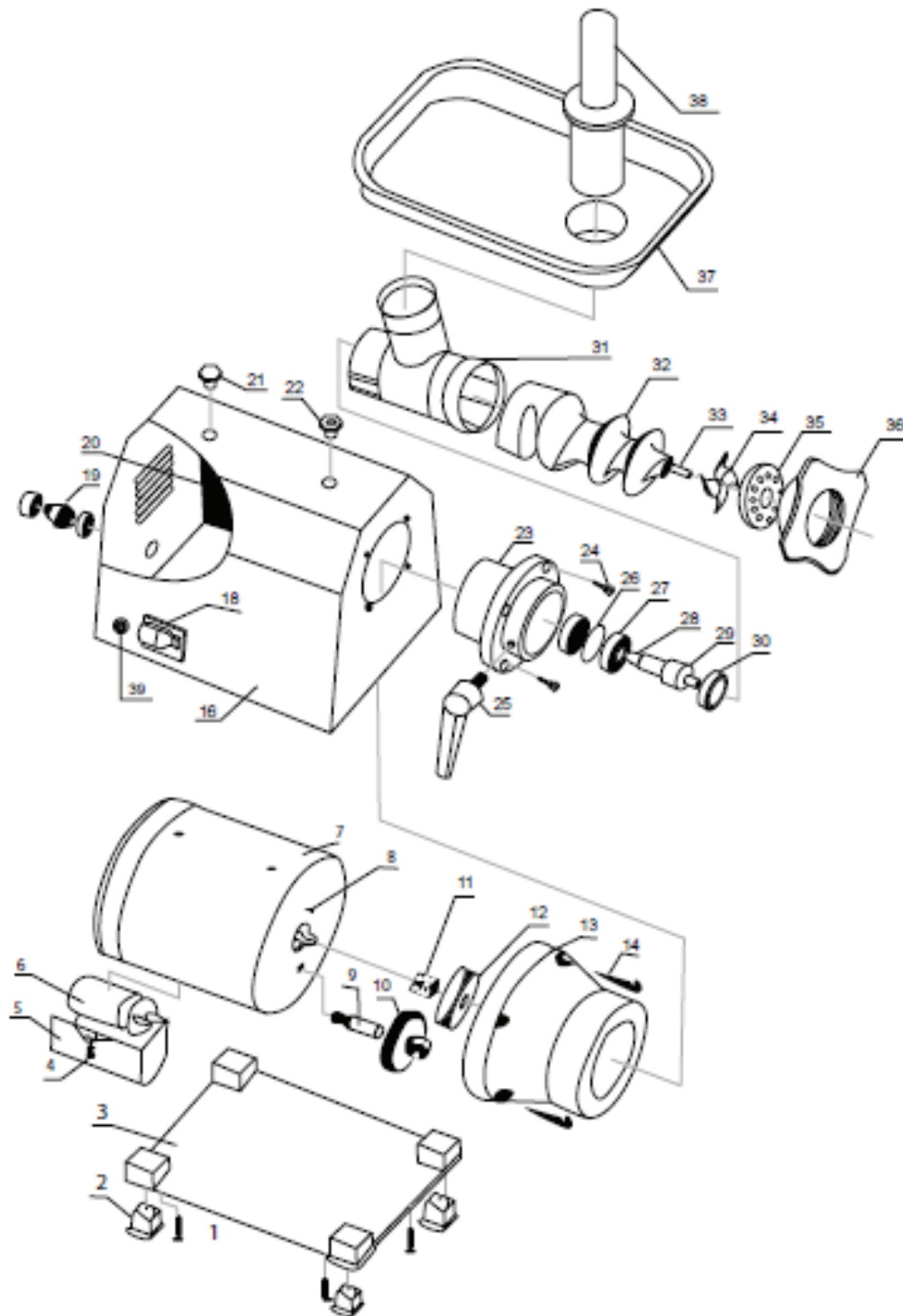

Parts Breakdown

Model MG-CN-0012-S 23580

Item No.	Description	Position	Item No.	Description	Position	Item No.	Description	Position
30953	Screw M5x32 for BSM12	1	30966	Screw M5x40 for BSM12	14	30978	Shaft for BSM12	29
30954	Foot for BSM12	2	30967	Case for BSM12	16	30979	Seal Oil for BSM12	30
30955	Bottom Plate for BSM12	3	30968	Switch for BSM12	18	31251	Head for BSM12	31
30956	Screw M4x8 for BSM12	4	30969	Cable Clips for BSM12	19	31252	Feed Screw for BSM12	32
30957	Capacitor Support for BSM12	5	30970	Sponge Pad for BSM12	20	30980	Arbor for BSM12	33
30958	Capacitor for BSM12	6	30971	Motor Locking Screw for BSM12	21	11077	#12 Machine Knife Stainless Steel for BSM12	34
30959	Motor for BSM12	7	30972	Oil Stopper for BSM12	22	11192	#12 Machine Plate with Hub 1/8 3.2mm One Notch Round for BSM12	35
30960	Key 4x12 for BSM12	8	31250	Grinder Mount for BSM12	23	30983	Retaining Nut for BSM12	36
30961	Shaft for BSM12	9	30973	Screw M6x20 for BSM12	24	30984	Feed Pan for BSM12	37
30962	Dual Gear for BSM12	10	30974	Lock Handle for BSM12	25	30985	Food Pusher for BSM12	38
30963	Gear I (13T) for BSM12	11	30975	Retainer Ring for BSM12	26	30986	Circuit Breaker for BSM12	39
30964	Gear IV (40T) for BSM12	12	30976	Ball Bearing for BSM12	27			
30965	Gearbox Case for BSM12	13	30977	Key 5x10 for BSM12	28			

Model MG-CN-0022-S 23626

Item No.	Description	Position	Item No.	Description	Position	Item No.	Description	Position
30987	Screw M5x32 for BSM22	1	31000	Screw M5x40 for BSM22	14	31012	Shaft for BSM22	29
30988	Foot for BSM22	2	31001	Case for BSM22	16	31013	Seal Oil for BSM22	30
30989	Bottom Plate for BSM22	3	31002	Switch for BSM22	18	30440	Head for BSM22	31
30990	Screw M4x8 for BSM22	4	31003	Cable Clips for BSM22	19	30441	Feed Screw for BSM22	32
30991	Capacitor Support for BSM22	5	31004	Sponge Pad for BSM22	20	31014	Arbor for BSM22	33
30992	Capacitor for BSM22	6	31005	Motor Locking Screw for BSM22	21	11078	#22 Machine Knife Stainless Steel for BSM22	34
30993	Motor for BSM22	7	31006	Oil Stopper for BSM22	22	11199	#22 Machine Plate with Hub 1/8 3.2mm One Notch Round for BSM22	35
30994	Key 4x12 for BSM22	8	30443	Grinder Mount for BSM22	23	31017	Retaining Nut for BSM22	36
30995	Shaft for BSM22	9	31007	Screw M6x20 for BSM22	24	31018	Feed Pan for BSM22	37
30996	Dual Gear for BSM22	10	31008	Lock Handle for BSM22	25	31019	Food Pusher for BSM22	38
30997	Gear I (13T) for BSM22	11	31009	Retainer Ring for BSM22	26	31020	Circuit Breaker for BSM22	39
30998	Gear IV (40T) for BSM22	12	31010	Ball Bearing for BSM22	27			
30999	Gearbox Case for BSM22	13	31011	Key 5x10 for BSM22	28			

Electrical Schematics

Model MG-CN-0012-S 23580

Model MG-CN-0022-S 23626

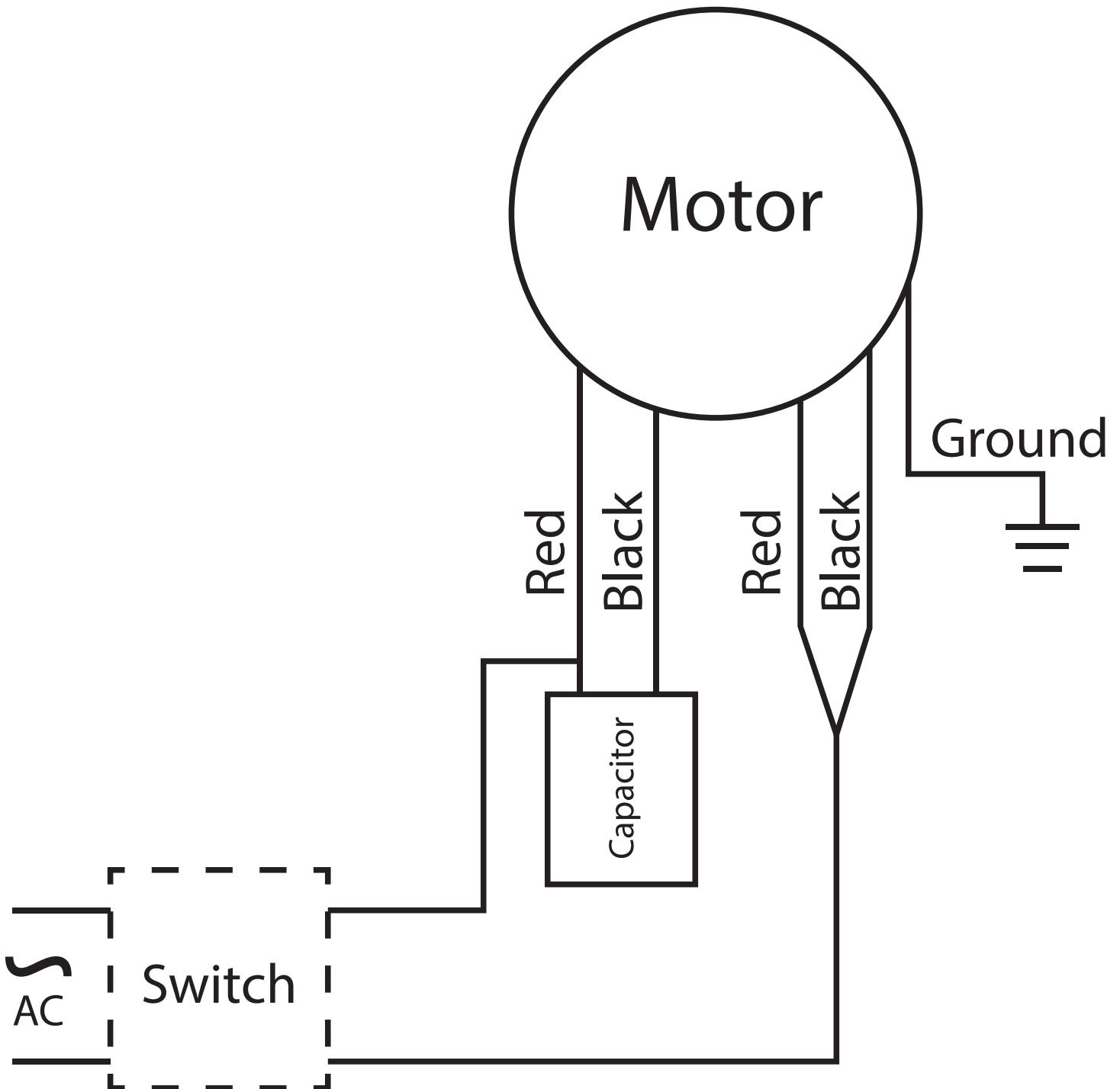



Warranty Registration

Thank you for purchasing an Omcan product. To register your warranty for this product, complete the information below, tear off the card at the perforation and then send to the address specified below. You can also register online by visiting:

Merci d'avoir acheté un produit Omcan. Pour enregistrer votre garantie pour ce produit, complétez les informations ci-dessous, détachez la carte au niveau de la perforation, puis l'envoyer à l'adresse spécifiée ci-dessous. Vous pouvez également vous inscrire en ligne en visitant:

Gracias por comprar un producto Omcan usted. Para registrar su garantía para este producto, complete la información a continuación, cortar la tarjeta en la perforación y luego enviarlo a la dirección indicada a continuación. También puede registrarse en línea en:

<https://omcan.com/warranty-registration/>

For mailing in Canada

Pour postale au Canada

Por correo en Canadá

OMCAN

PRODUCT WARRANTY REGISTRATION

3115 Pepper Mill Court,

Mississauga, Ontario

Canada, L5L 4X5

For mailing in the US

Pour diffusion aux États-Unis

Por correo en los EE.UU.

OMCAN

PRODUCT WARRANTY REGISTRATION

4450 Witmer Industrial Estates, Unit 4,

Niagara Falls, New York

USA, 14305

or email to: service@omcan.com



Purchaser's Information

Name: _____

Address: _____

City: _____ Province or State: _____ Postal or Zip: _____

Country: _____

Dealer from which Purchased: _____

Dealer City: _____ Dealer Province or State: _____

Invoice: _____

Model Name: _____ Model Number: _____

Machine Description: _____

Date of Purchase (MM/DD/YYYY): _____

Would you like to extend the warranty? Yes No

Company Name: _____

Telephone: _____

Email Address: _____

Type of Company:

Restaurant Bakery Deli

Butcher Supermarket Caterer

Institution (*specify*): _____

Other (*specify*): _____

Serial Number: _____

Date of Installation (MM/DD/YYYY): _____

Thank you for choosing Omcan | Merci d'avoir choisi Omcan | Gracias por elegir Omcan



Since 1951 Omcan has grown to become a leading distributor of equipment and supplies to the North American food service industry. Our success over these many years can be attributed to our commitment to strengthen and develop new and existing relationships with our valued customers and manufacturers. Today with partners in North America, Europe, Asia and South America, we continually work to improve and grow the company. We strive to offer customers exceptional value through our qualified local sales and service representatives who provide convenient access to over 5,000 globally sourced products.

Depuis 1951 Omcan a grandi pour devenir un des “leaders” de la distribution des équipements et matériel pour l’industrie des services alimentaires en Amérique du Nord. Notre succès au cours de ces nombreuses années peut être attribué à notre engagement à renforcer et à développer de nouvelles et existantes relations avec nos clients et les fabricants de valeur. Aujourd’hui avec des partenaires en Amérique du Nord, Europe, Asie et Amérique du Sud, nous travaillons continuellement à améliorer et développer l’entreprise. Nous nous efforçons d’offrir à nos clients une valeur exceptionnelle grâce à nos ventes locales qualifiées et des représentants de service qui offrent un accès facile à plus de 5000 produits provenant du monde entier.

Desde 1951 Omcan ha crecido hasta convertirse en un líder en la distribución de equipos y suministros de alimentos en América del Norte industria de servicios. Nuestro éxito en estos años se puede atribuir a nuestro compromiso de fortalecer y desarrollar nuevas relaciones existentes con nuestros valiosos clientes y fabricantes. Hoy con socios de América del Norte, Europa, Asia y América del Sur, que trabajan continuamente para mejorar y crecer la empresa. Nos esforzamos por ofrecer a nuestros clientes valor excepcional a través de nuestro local de ventas y representantes de los servicios que proporcionan un fácil acceso a más de 5,000 productos con origen a nivel mundial.

