



Horizontal Gear-Driven Slicers
Model MS-IT-0300-H, 0330-H, 0350-PM
Items 13655, 13656, 13657
Instruction Manual



STOP
DO NOT RETURN
THIS PRODUCT TO THE STORE

For questions or assistance with this product call OMCAN Toll Free:
1 800 465 0234
Customer Service
or
visit the Support section of
www.omcan.com

Revised - 11/10/2016



Toll Free: 1-800-465-0234
Fax: 905-607-0234
Email: service@omcan.com
www.omcan.com

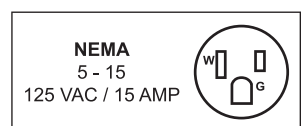

Table of Contents

Model MS-IT-0300-H / Model MS-IT-0330-H / Model MS-IT-0350-PM

Section	Page
General Information -----	3 - 4
Safety and Warranty -----	4 - 5
Technical Specifications -----	6
Installation -----	6 - 7
Operation -----	7
Maintenance -----	7 - 9
Illustrated Drawings -----	10
Parts Breakdown -----	11 - 19
Electrical Schematics -----	20
Notes -----	21 - 22
Warranty Registration -----	23



General Information

Omcan Manufacturing and Distributing Company Inc., Food Machinery of America, Inc. dba Omcan and Omcan Inc. are not responsible for any harm or injury caused due to any person's improper or negligent use of this equipment. The product shall only be operated by someone over the age of 18, of sound mind, and not under the influence of any drugs or alcohol, who has been trained in the correct operation of this machine, and is wearing authorized, proper safety clothing. Any modification to the machine voids any warranty, and may cause harm to individuals using the machine or in the vicinity of the machine while in operation.

CHECK PACKAGE UPON ARRIVAL

Upon receipt of an Omcan shipment please inspect for external damage. If no damage is evident on the external packaging, open carton to ensure all ordered items are within the box, and there is no concealed damage to the machine. If the package has suffered rough handling, bumps or damage (visible or concealed), please note it on the bill of lading before accepting the delivery and contact Omcan within 24 hours, so we may initiate a claim with the carrier. A detailed report on the extent of the damage caused to the machine must be filled out within three days, from the delivery date shown in the shipping documents. Omcan has no recourse for damaged products that were shipped collect or third party.

Before operating any equipment, always read and familiarize yourself with all operation and safety instructions.

Omcan would like to thank you for purchasing this machine. It's of the utmost importance to save these instructions for future reference. Also save the original box and packaging for shipping the equipment if servicing or returning of the machine is required.

Omcan Fabrication et distribution Compañie Limité et Food Machinery d'Amerique, dba Omcan et Omcan Inc. ne sont pas responsables de tout dommage ou blessure causé du fait que toute personne ait utilisé cet équipement de façon irrégulière. Le produit ne doit être exploité que par quelqu'un de plus de 18 ans, saine d'esprit, et pas sous l'influence d'une drogue ou d'acohol, qui a été formé pour utiliser cette machine correctement, et est vêtu de vêtements de sécurité approprié. Toute modification de la machine annule toute garantie, et peut causer un préjudice à des personnes utilisant la machine ou des personnes à proximité de la machine pendant son fonctionnement.

VÉRIFIEZ LE COLIS DÈS RÉCEPTION

Dès réception d'une expédition d'Omcan veuillez inspecter pour dommages externes. Si aucun dommage n'est visible sur l'emballage externe, ouvrez le carton afin de s'assurer que tous les éléments commandés sont dans la boîte, et il n'y a aucun dommage dissimulé à la machine. Si le colis n'a subi aucune mauvaises manipulations, de bosses ou de dommages (visible ou cachée), notez-le sur le bond de livraison avant d'accepter la livraison et contactez Omcan dans les 24 heures qui suivent, pour que nous puissions engager une réclamation auprès du transporteur. Un rapport détaillé sur l'étendue des dommages causés à la machine doit être rempli dans un délai de trois jours, à compter de la date de livraison indiquée dans les documents d'expédition. Omcan n'a aucun droit de recours pour les produits endommagés qui ont été expédiées ou cueilli par un tiers transporteur.

General Information

Avant d'utiliser n'importe quel équipement, toujours lire et vous familiariser avec toutes les opérations et les consignes de sécurité.

Omcan voudrais vous remercier d'avoir choisi cette machine. Il est primordial de conserver ces instructions pour une référence ultérieure. Également conservez la boîte originale et l'emballage pour l'expédition de l'équipement si l'entretien ou le retour de la machine est nécessaire.

Omcan Empresa De Fabricacion Y Distribucion Inc. Y Maquinaria De Alimentos De America, Inc. dba Omcan y Omcan Inc. no son responsables de ningun daño o perjuicio causado por cualquier persona inadecuada o el uso descuidado de este equipo. El producto solo podra ser operado por una persona mayor de 18 años, en su sano juicio y no bajo alguna influencia de droga o alcohol, y que este ha sido entrenado en el correcto funcionamiento de esta máquina, y ésta usando ropa apropiada y autorizada. Cualquier modificación a la máquina anula la garantía y puede causar daños a las personas usando la máquina mientras esta en el funcionamiento.

REVISE EL PAQUETE A SU LLEGADA

Tras la recepcion de un envio Omcan favor inspeccionar daños externos. Si no hay daños evidentes en el empaque exterior, Habra el carton para asegurarse que todos los articulos solicitados estén dentro de la caja y no encuentre daños ocultos en la máquina. Si el paquete ha sufrido un manejo de poco cuidado, golpes o daños (visible o oculto) por favor anote en la factura antes de aceptar la entrega y contacte Omcan dentro de las 24 horas, de modo que podamos iniciar una reclamación con la compañía. Un informe detallado sobre los daños causados a la máquina debe ser llenado en el plazo de tres días, desde la fecha de entrega que se muestra en los documentos de envío. Omcan no tiene ningun recurso por productos dañados que se enviaron a recoger por terceros.

Antes de utilizar cualquier equipo, siempre leer y familiarizarse con todas las instrucciones de operación y seguridad.

Omcan quisiera darles las gracias por la compra de esta máquina. Es de la máxima importancia para guardar estas instrucciones para referencias en el futuro. También guarde la caja original y el embalaje para envío del equipo si el mantenimiento o la devolución de la máquina es necesaria.

Safety and Warranty

GENERAL SAFETY REGULATIONS

The slicer must be used only by suitably trained personnel. Furthermore, this personnel must have read this manual carefully. In particular, please comply to the following instructions:

- Install the machine according to the instructions contained in the "Installation" section.
- Do not remove the transparent protections, and do not modify nor exclude the mechanical and electrical

Safety and Warranty

safety devices.

- Do not use the machine with improvised connections, or provisional or non insulated cables.
- Check the power cable and gland plate on the machine body regularly and, when necessary, have them replaced by qualified personnel.
- In case of anomalies, defective operation, incorrect movement, and/or unusual noise, stop the machine immediately.
- Before cleaning or servicing, disconnect the machine from the mains.
- Always use protection gloves during cleaning or maintenance.
- Lay or remove the goods to be sliced on the sliding plate only when the latter is completely pushed back and the thickness control knob positioned to 0.
- To move the carriage tray when slicing, use the handle or the product grip handle.
- For extraordinary maintenance (to replace the sharpener wheels, the blade, etc), please contact the manufacturer or qualified and duly authorized personnel.
- Avoid running the slicers with no product on it.
- The slicers are equipped with a ventilated motor. Extended continual use is not recommended. Let the motor cool down after 30 minutes of use.

1 YEAR PARTS AND BENCH WARRANTY

Within the warranty period, contact Omcan Inc. at 1-800-465-0234 to schedule a drop off to either an Omcan authorized service depot in the area, or to an Omcan Service warehouse to repair the equipment.

Unauthorized maintenance will void the warranty. Warranty covers electrical and part failures, not improper use.

Please see www.omcan.com/warranty.html for complete info.



WARNING:

The packaging components are classified as normal solid urban waste and can therefore be disposed of without difficulty.

In any case, for suitable recycling, we suggest disposing of the products separately (differentiated waste) according to the current norms.

DO NOT DISCARD ANY PACKAGING MATERIALS IN THE ENVIRONMENT!

Technical Specifications

Model	MS-IT-0300-H	MS-IT-0330-H	MS-IT-0350-PM
Blade Size	12" / 300 mm	13" / 330 mm	14" / 350 mm
Power	0.35 HP / 0.26 kW	0.35 HP / 0.26 kW	0.35 HP / 0.26 kW
Cheese Slicing*			
Slicing Volume*	8 hours or more	8 hours or more	8 hours or more
RPM	250	250	250
Cutting Size	11" x 9" 279 x 229 mm	11.81" x 9.84" 300 x 250 mm	12.20" x 10.63" 310 x 270 mm
Cut Thickness	0-25mm	0-25mm	0-15mm
Electrical	110V / 60 Hz / 1 Ph	110V / 60 Hz / 1 Ph	110V / 60 Hz / 1 Ph
Weight	95 lbs. / 43 kg.	99 lbs. / 45 kg.	110 lbs. / 50 kg.
Dimensions (WDH)	30" x 25.6" 18.5" 762 x 650 x 470 mm	30" x 25.6" x 19" 762 x 650 x 483 mm	32.25" x 27" x 20.25" 819 x 686 x 514 mm
Item Number	13655	13656	13657

*Results may vary due to product consistency and temperature

Installation

UNPACKING

Immediately after unpacking the slicer, check it for possible shipping damage. If this machine is found to be damaged after unpacking, save the packing material and contact the carrier within 15 days of delivery.

Prior to installation, test the electrical service to assure that it agrees with the specifications on the machine data plate.

ELECTRICAL

WARNING: It must be connected to properly grounding plug, grounded outlet. If the receptacle is not the proper grounding type, contact an electrician.

CLEANING

This machine must be thoroughly cleaned and sanitized after installation and before being put into service.

SAFETY

Safety devices incorporated in this slicer must be in their correct operating positions anytime the slicer is in

Installation

- use.
- The blade cover (6) must be in position over the knife and secured by tightening the hand knob (7).
 - The last slice device (4) must be used when slicing it keep your hands away from the knife. When the slicer is not running, the slicer thickness control (2) must be set to zero (fully clockwise) to prevent the blade edge from being exposed.
 - Always UNPLUG the power cord before cleaning or moving the slicer.

Operation

- Pull the product holder (3) towards you until it stops and place the product to be sliced on the product holder tray.
- Set the last slice device against the product and switch on the slicer by pressing the on-off switch (9).
- Adjust the slice thickness by turning the slice thickness control.
- The numbers on the slice thickness control do not indicate actual measurements but may be used for reference to duplicate slice thickness.
- Using the last slice device (4), push the product holder (3) back and forth to slice.
- Always switch-off the slicer and turn the slice thickness control clockwise to zero when not slicing.

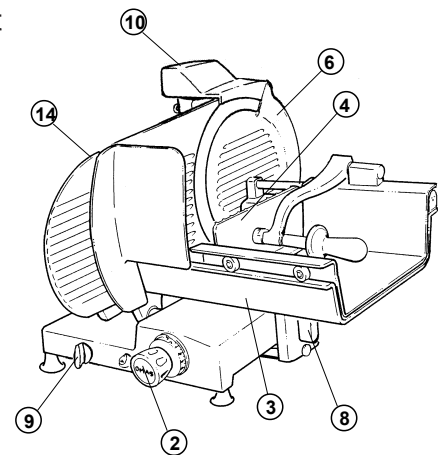

Maintenance

CLEANING

This machine must be thoroughly cleaned after each day's operation or anytime it will not be used for an extended period of time.

WARNING: Unplug machine power cord and turn the index knob fully clockwise before cleaning the slicer.

- Turn the slice deflector (12) for easy cleaning back of the blade.
- The product holder can be removed for an easy cleaning by rotating its handle counterclockwise (8).
- Using a mild soap, hot water solution, and a clean cloth, wipe all surfaces of the slicer.
- Thoroughly rinse it with another clean cloth and fresh water.
- Remove the blade cover by removing the hand knob (7).

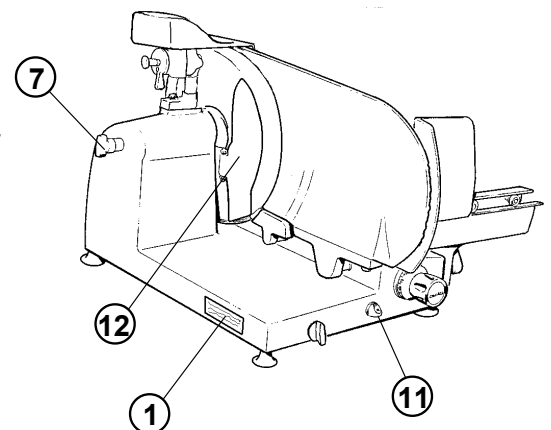

Maintenance

- With the hand knob removed, grasp the edge of the blade cover and carefully lift it straight off the knife.

WARNING: The slicer blade is very sharp. Use extreme caution when working near the blade.

- CAREFULLY wash both sides of the blade with the slice thickness control turned fully clockwise.
- Wash the blade by wiping outward from the center.
- ALWAYS rinse the blade thoroughly using fresh water and a clean cloth. Never use steel pads to clean the blade. Wash and thoroughly rinse the removed components prior to reassembling them.
- DO NOT wash any slicer components in a dishwasher.

BLADE SHARPENING

Attention: Use protection gloves

Your slicer blade will provide long service in normal deli, food store, or commercial kitchen use. However, in high volume applications where it is a practice to sharpen the blade frequently or even daily, the blade will be expended in a shorter time.

- Before using the sharpener, make sure that the front and back side of the knife edge is clean and free of grease.
- To sharpen knife:
 - a) Be sure that the slicer has been switched off.
 - b) Rotate the slice thickness control (4) into "O" position, so that the thickness plate (5) protects the knife. (Fig. 2)
- Lift up the sharpener cover (1). (Fig. 2)
- Disengage the pin (7) and rotate the sharpener (3). (Fig. 3)
- The sharpener, then, goes into its sharpening position. (Fig. 4)
- To sharpen, turn the switch first in the ON position, so that the knife turns. Then, slowly rotate the lever which lets both stones go in contact with the knife; sharpening and trimming are made at the same time. (Fig. 5)
- Replace the sharpener to normal horizontal position by lifting the pin (7) and close the cover. (Fig. 6)
- The grinding stone (6), fitted on its pin, can be easily removed by just drawing it. (Fig. 7) To get a nice sharpening, the grinding stone must be clean and free of grease.
- The sharpening time depends on the wear of the knife. To get a good result, the time needed is 10 to 15 seconds. A longer sharpening reduce the duration of the knife and gives no advantage.
- Wipe the slicer with a clean damp cloth to remove any grinding particles.

LUBRICATION

- The rod on which the product holder slides, which is underneath the slicer, should be lubricated weekly with several drops of oil. Stop the carriage at the end of the stroke nearest the operator and pour the lubricant into the special oiler. DO NOT use vegetable oil.
- Occasionally, the slice thickness plate slide rod should be coated lightly with lubricant.
- Turn the slice thickness control fully counterclockwise when lubricating this slide rod and then turn it fully clockwise when finished. DO NOT lubricate the rod on which the last slice device slides. It must be kept clean but not lubricated. The motor has sealed bearings and requires no lubrication maintenance.

WEAR ADJUSTMENT

After several, years of operation and many sharpening of the blade it may become necessary to have the slice thickness plate (14) adjusted closer to the blade.

REFERENCE

Item Number	Model Number	Description	Manufacturer Model Number
13655	MS-IT-0300-H	Meat Slicer Gear Driven Horizontal 12" / 300mm Blade 0.35 HP / 261 W 110V/60/1 NSF cETL cULus	H300
13656	MS-IT-0330-H	Meat Slicer Gear Driven Horizontal 13" / 330mm Blade 0.35 HP / 261 W 110V/60/1 NSF cETL cULus	H330
13657	MS-IT-0350-PM	Meat Slicer Gear Driven Horizontal 14" / 350mm Blade 0.35 HP / 261 W 110V/60/1 NSF cETL cULus	H350

Illustrated Drawings

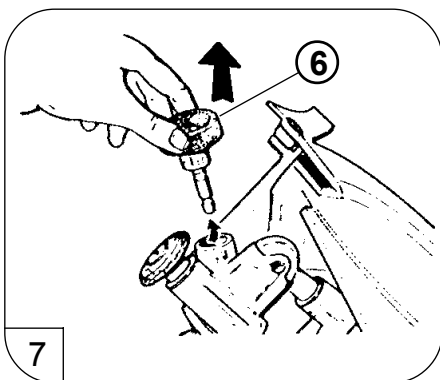
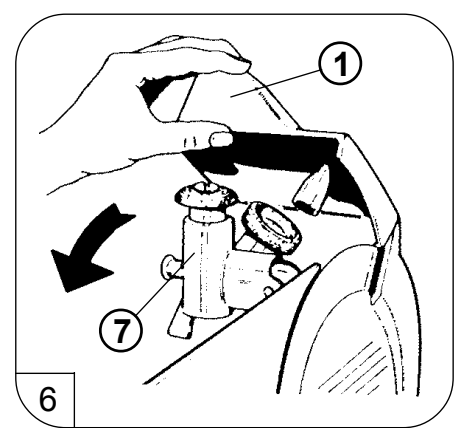
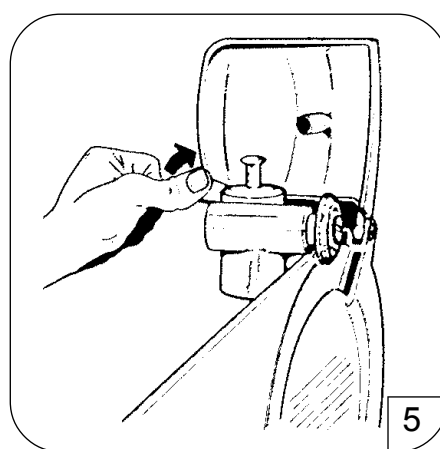
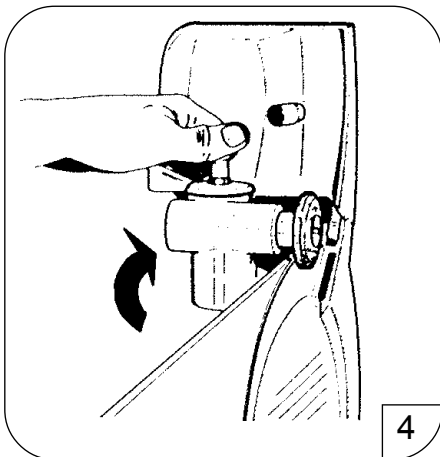
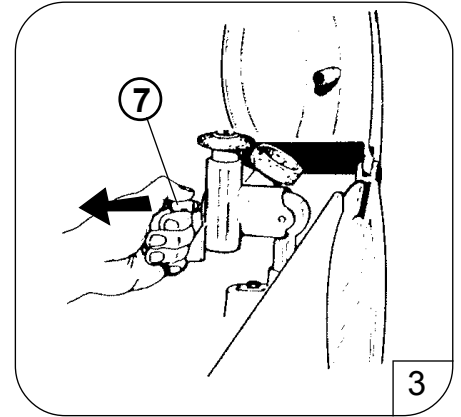
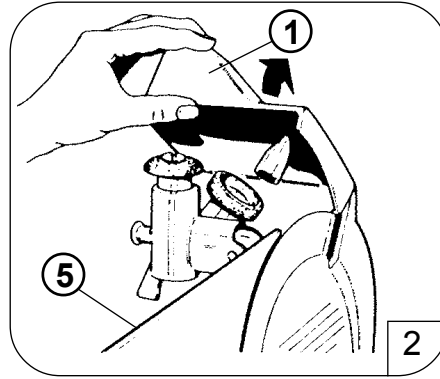
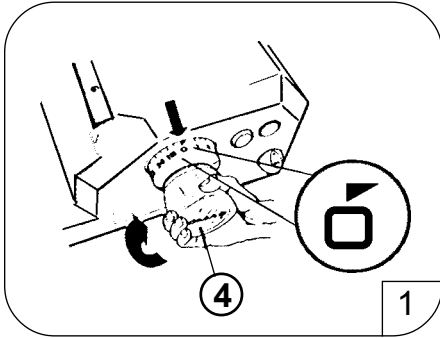

Parts Breakdown

Model MS-IT-0300-H 13655

Model MS-IT-0330-H 13656

Model MS-IT-0350-PM 13657

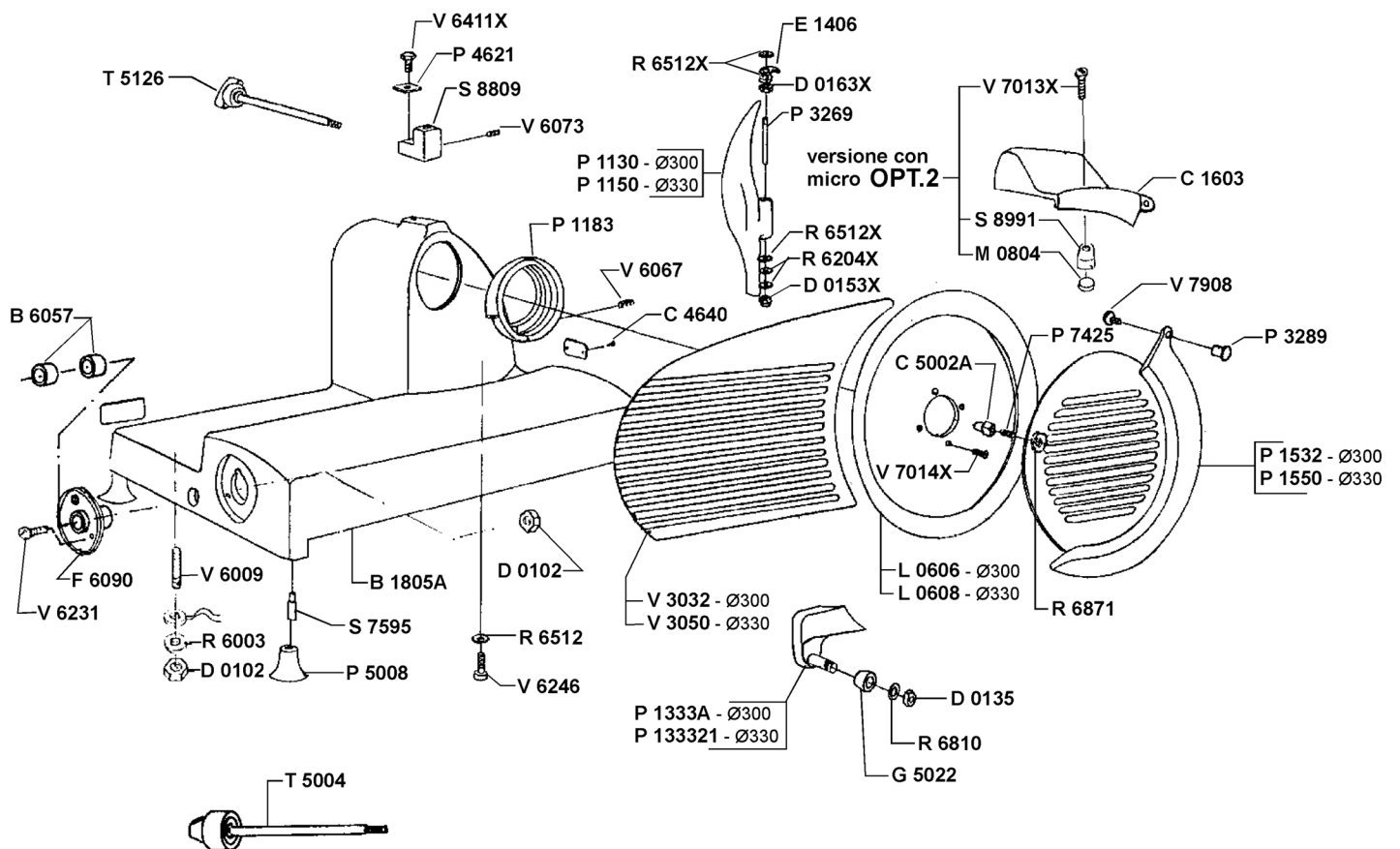

Parts Breakdown

Model MS-IT-0300-H 13655

Model MS-IT-0330-H 13656

Model MS-IT-0350-PM 13657

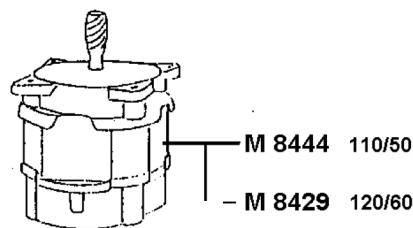
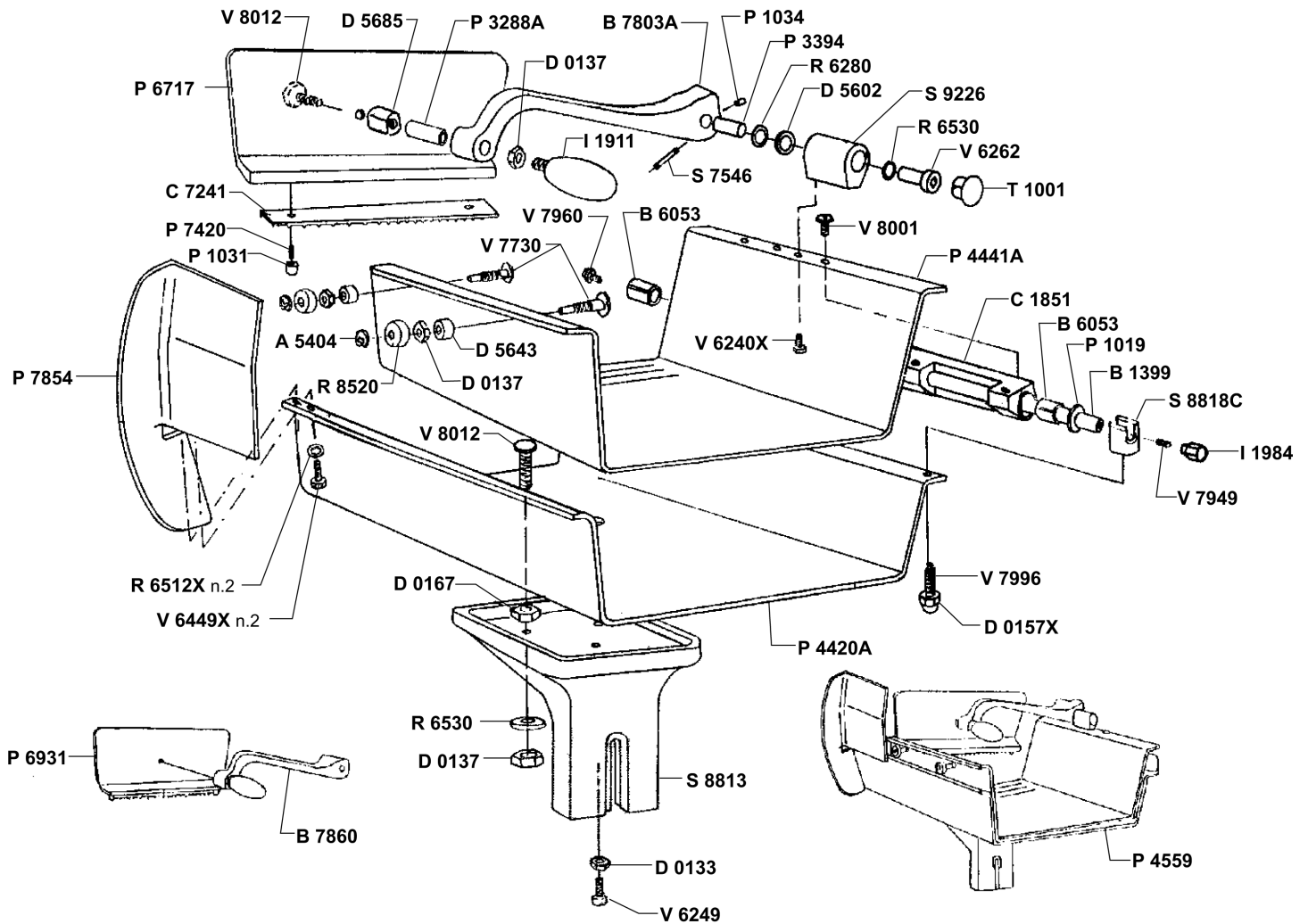

Parts Breakdown

Model MS-IT-0300-H 13655

Model MS-IT-0330-H 13656

Model MS-IT-0350-PM 13657

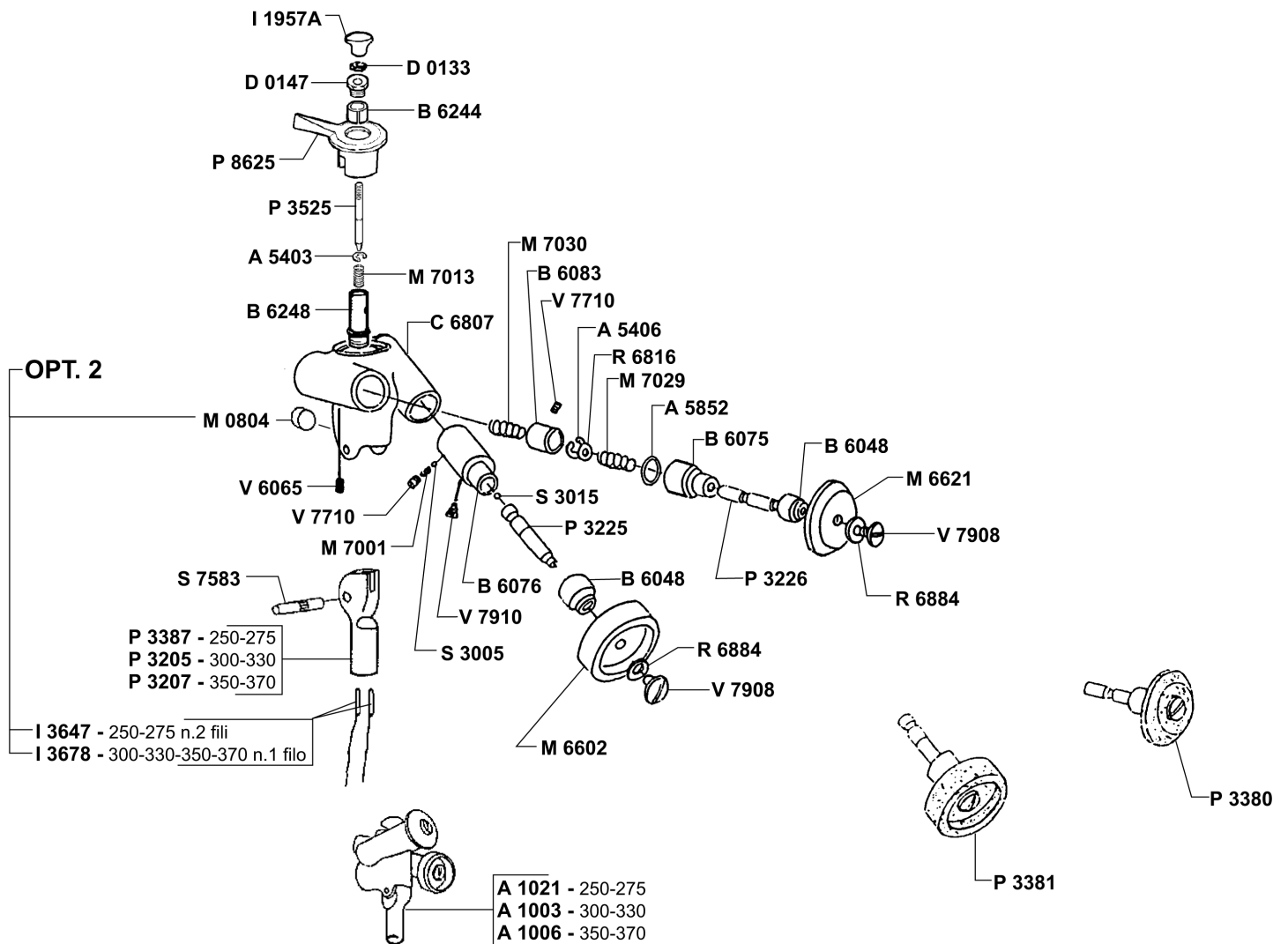

Parts Breakdown

Model MS-IT-0300-H 13655

Model MS-IT-0330-H 13656

Model MS-IT-0350-PM 13657

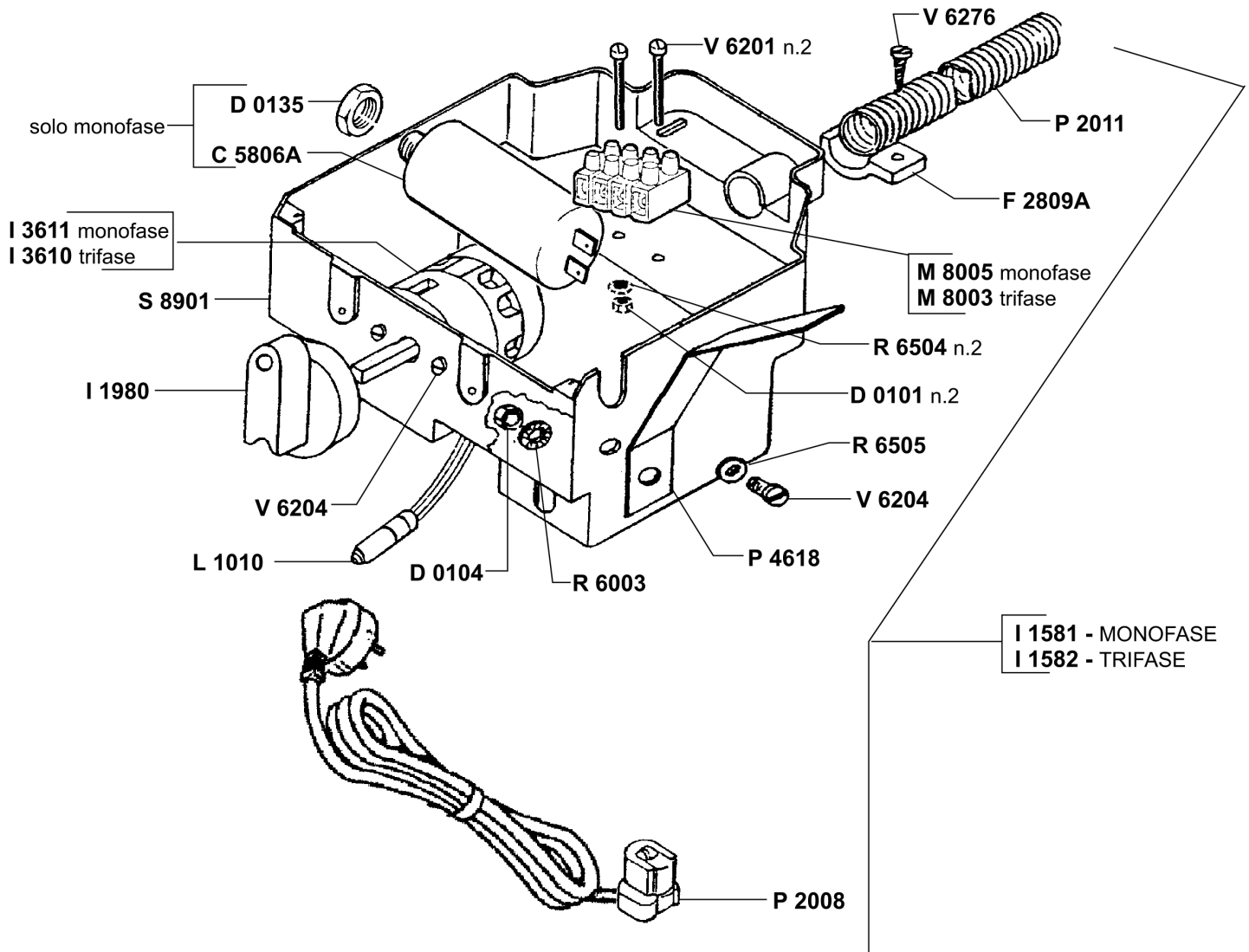

Parts Breakdown

Model MS-IT-0300-H 13655

Model MS-IT-0330-H 13656

Model MS-IT-0350-PM 13657

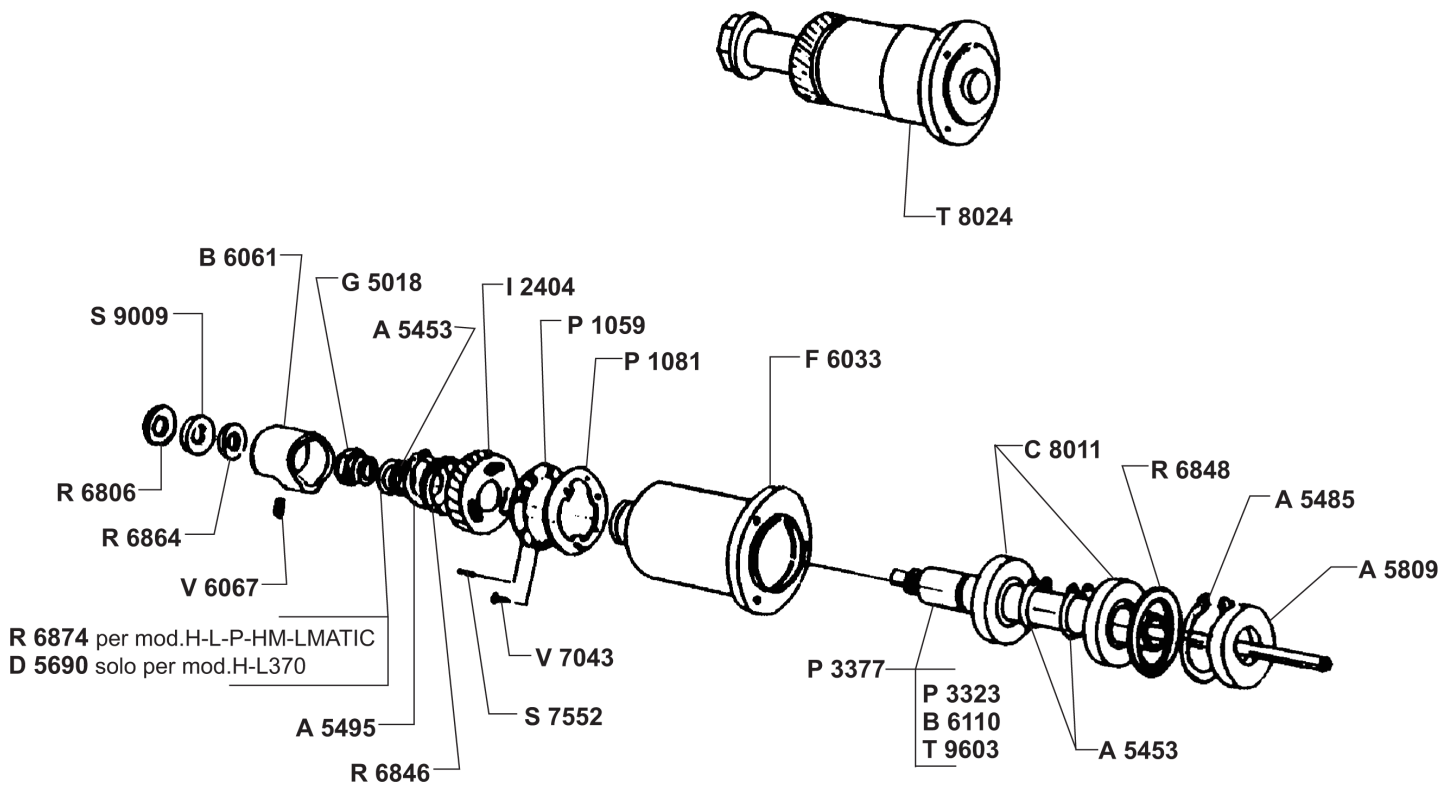

Parts Breakdown

Model MS-IT-0300-H 13655

Model MS-IT-0330-H 13656

Model MS-IT-0350-PM 13657

Item No.	Description	Position	Item No.	Description	Position	Item No.	Description	Position
17272	Sharpening Assembly (Support & Stones) for H300, H330, H350	A1003	78265	Bushing, Funnel H-L-C (OMAS) for H300, H330, H350	B6110	19645	Nut M10 for H300, H330, H350	D0167
16899	Sharpening Assembly for H300, H330, H350	A1006	17312	Bushing 22 x 25 x 20 for H300, H330, H350	B6211	19547	Nut for H300, H330, H350	D0190
78234	Sharpening Assembly (Support & Stones) (OMAS) for H300, H330, H350	A1021	36566	Bushing to hold Carriage Springs for H300, H330, H350	B6221	19648	Knife Spacer for H300, H330, H350	D5602
17279	Ring EL.Benzing 5 for H300, H330, H350	A5403	17313	Bushing DU 14 x 15 x 16 for H300, H330, H350	B6244	17341	Spacer D.10.5 x 14 H.9 for H300, H330, H350	D5643
17280	Ring EL.Benzing 5 for H300, H330, H350	A5404	36571	Bushing Pivot Affil. H-L-P-M-C (CE) for H300, H330, H350	B6248	19553	Meat Grip Spacer H for H300, H330, H350	D5685
16902	Ring EL.Benzing 8 for H300, H330, H350	A5406	36577	Meat Grip Arm H250 for H300, H330, H350	B7803A	39410	Space Aluminum for H370 for H300, H330, H350	D5690
17281	Ring EL.Seeger Ext.25 for H300, H330, H350	A5453	16909	Sharpener Cover H-L-C for H300, H330, H350	C1603	36661	Carriage Shock Absorber Spacer for H300, H330, H350	D5762
19484	Ring 52 for H300, H330, H350	A5485	36590	AG35-C-H Carriage for H300, H330, H350	C1854	30459	E1406 Stop Cam for H350 for H300, H330, H350	E1406
19612	Ring 33 for H300, H330, H350	A5495	20423	Pin for H300, H330, H350	C4620	17342	CAM 15 mm for H300, H330, H350	E1420
17283	Oil Seal 25 x 52 x 10 for H300, H330, H350	A5809	36601	Rivet 1.9 x 5 for H300, H330, H350	C4640	19559	CAM 25 mm for H300, H330, H350	E1422
17287	O-Ring 123 17.86 x 2.62 for H300, H330, H350	A5852	17325	Capacitor VS for H300, H330, H350	C5806	17345	CAM Bearing H300 for H300, H330, H350	E1458
36544	Carriage Rod H-L-C300/330/350 for H300, H330, H350	B1010A	19534	Housing Sharpener H for H300, H330, H350	C6807	36680	Carriage Felt C Matic for H300, H330, H350	F1606
19496	Carriage Rod C-H for H300, H330, H350	B1095	19535	Rack H300/330 for H300, H330, H350	C7241	36681	Cord Holder H-L-C for H300, H330, H350	F2809A
36548	Shock Absorber Bar 12 x 170 for H300, H330, H350	B1251	24607	Bearing 2Z-6205 25 x 252 x 15 for C300 for H300, H330, H350	C8011	17347	Knife Support Flange H-L for H300, H330, H350	F6033
19507	Carriage Rod A310 for H300, H330, H350	B1372A	19637	Nut M3 for H300, H330, H350	D0101	17349	Handle Flange for H300, H330, H350	F6090
17296	Tray Rod H300/330 for H300, H330, H350	B1399	36634	Nut U5587 M3.5 for H300, H330, H350	D0104	17351	Locknut H-L-C for H300, H330, H350	G5018
16904	Bushing Sharpener H-L-C for H300, H330, H350	B6048	16928	Nut U5589 M6 for H300, H330, H350	D0133	36688	Locknut H-L300/330 for H300, H330, H350	G5022
16905	Bushing DU 16 x 18 x 15 for H300, H330, H350	B6053	19639	Nut M8 for H300, H330, H350	D0135	17355	Handle for H300, H330, H350	I1911
17304	Bushing for H300, H330, H350	B6056	17337	Nut U5589 M10 6S for H300, H330, H350	D0137	19587	Sharpener Knob for H300, H330, H350	I1957A
17305	Bushing DU 18 x 20 x 15 for H300, H330, H350	B6057	36640	Stainless Steel Domed Nut U5721 M6 for H300, H330, H350	D0153X	36707	Switch Handle for H300, H330, H350	I1980
19514	Bushing Guard A310 for H300, H330, H350	B6061	19643	Nut M10 for H300, H330, H350	D0157X	18222	Rod Meat Grip Handle H for H300, H330, H350	I1984
16906	Bush Sharpening H-L-C for H300, H330, H350	B6075	19644	Nut M6 for H300, H330, H350	D0163	17364	Nylon Gear H300/H330 DP 56, 80, Z29 for H300, H330, H350	I2404
16907	Bush Sharpening H-L-C for H300, H330, H350	B6076	36646	Stainless Steel Nut U5588 M6 for H300, H330, H350	D0163X	78585	Switch 380/50/3 for H300, H330, H350	I3610
17307	Bushing Sharpener H-L-C for H300, H330, H350	B6083	36647	Nut U5588 M8 for H300, H330, H350	D0165	16938	Switch and Knob HL C GF 310 for H300, H330, H350	I3611

Parts Breakdown

Model MS-IT-0300-H 13655

Model MS-IT-0330-H 13656

Model MS-IT-0350-PM 13657

Item No.	Description	Position	Item No.	Description	Position	Item No.	Description	Position
17369	Switch 4 x 20 for H300, H330, H350	I3647	17402	Deflector HM-HP for H300, H330, H350	P1130	19831	Gauge Plate Flat Bar VS for H300, H330, H350	P4621
36723	Switch 4 x 25 for H300, H330, H350	I3678	19805	Deflector HLC 330 for H300, H330, H350	P1150	19832	Flat Bar H-L for H300, H330, H350	P4651
78577	Knife 300 mm; Hole 57 mm for H300, H330, H350	L0606	17406	Ring Deflector for H300, H330, H350	P1183	18221	Slide Rail Flat 20 x 400 for H300, H330, H350	P4815
13568	Knife 330 mm for H300, H330, H350	L0608	36764	Slice Deflector H-L-P 330 for H300, H330, H350	P133321	16961	Foot H/C/L VS/GL/GF for H300, H330, H350	P5008
36731	Lamp 220V. for H300, H330, H350	L1010	17410	Blade Guard Cover C300 for H300, H330, H350	P1532	36844	End Grip Assembly H300/330 for H300, H330, H350	P6717
36733	Magnet 8 x 10 for H300, H330, H350	M0803	17412	Knife Guard H-L-C330 for H300, H330, H350	P1550	19655	Meat Grip Stud H for H300, H330, H350	P7420
36734	Magnet 12 x 6 for H300, H330, H350	M0804	17415	Strain Relief for H300, H330, H350	P2008	16964	Stud Guard Knife C for H300, H330, H350	P7425
14787	Grinding Stone C (OMAS) for H300, H330, H350	M6602	74413	Cable Sheath Cavoflex CM 60 for BG80E for H300, H330, H350	P2011	17444	Stud Carriage H-L-C for H300, H330, H350	P7431
36741	Stainless Steel Spring 2.9 x 4 x 12 for H300, H330, H350	M7001	19811	Pin Sharpener HLC 300/330 for H300, H330, H350	P3205	36854	Thumb Protection H300 for H300, H330, H350	P7854
17377	Stainless Steel Spring 8.5 x 1.0 x 25 for H300, H330, H350	M7013	17416	Pin Sharpener C350/370 for H300, H330, H350	P3207	24030	HLC Sharpener Operating Handle for H300, H330, H350	P8625
17379	Stainless Steel Spring 11.9 x0.7 x 27 for H300, H330, H350	M7029	16959	Pin Grinding H-L-C for H300, H330, H350	P3225	19657	Washer 4 for H300, H330, H350	R6003
17380	Stainless Steel Spring 13.4 x 1.3 x 30 for H300, H330, H350	M7030	17419	Pin Truing H-L-C for H300, H330, H350	P322601	19661	Washer 8 for H300, H330, H350	R6030
19776	Spring 14 x 1.5 x 60 for H300, H330, H350	M7032	17422	Pin Deflector H-L-C for H300, H330, H350	P3269	36876	Stainless Steel Washer 6.2 x 12.5 x 0.7 for H300, H330, H350	R6204X
17381	Spring 22 5x1 8x18 for H300, H330, H350	M7052	19822	Pin Handle Meat Grip for H300, H330, H350	P3288A	19666	Washer for H300, H330, H350	R6280
19248	Spring 15.6*20*2.2 for H300, H330, H350	M7120	19824	Pin Guard Knife HL for H300, H330, H350	P3377	36880	Washer U6592 3 for H300, H330, H350	R6504
20459	Terminal Strip for H300, H330, H350	M8005	78584	Assembly Honing Stone Pin H-L-C for H300, H330, H350	P3380	16967	Washer U65926 for H300, H330, H350	R6512
17385	Motor 120//60 H for H300, H330, H350	M8429	17427	Assembly Grinding Stone Pin H-L-C for H300, H330, H350	P3381	17457	Stainless Steel Washer U6592 6 for H300, H330, H350	R6512X
19791	Oiler H-L-C for H300, H330, H350	O4040	78233	Pin Sharpener HLC 250/275 (OMAS) for H300, H330, H350	P3387	19668	Washer 10 for H300, H330, H350	R6530
17390	Rubber Shock Abs. 16 x 22 x 2.5 for H300, H330, H350	P1019	19825	Pin Support Meat Grip for H300, H330, H350	P3394	17458	Contact Washer for H300, H330, H350	R6806
19796	Plastic Shock for H300, H330, H350	P1031	36801	Pivot Sgancio Sharpener H/L-C for H300, H330, H350	P3525	36889	Washer 10.5 x 16 x 1 for H300, H330, H350	R6816
17392	Pl.Shock Absorb. 8.5 x 20 for H300, H330, H350	P1034	36808	Tray H300/330 for H300, H330, H350	P4420A	16969	Washer 18.2 x 25 x 0.5 for H300, H330, H350	R6840
36761	Shock Absorber for H300, H330, H350	P103401	36811	Tray H300/330 for H300, H330, H350	P4441A	17460	Washer 34.2 x 46 x 0.5 for H300, H330, H350	R6846
16955	Shock Absorber H-L-C for H300, H330, H350	P1059	36823	Tray Assembly H300/330 for H300, H330, H350	P4559	77595	Washer 44.5 x 51.5 x 0.2 (OMAS) for H300, H330, H350	R6848
17395	Shock Absorber H-L-C for H300, H330, H350	P1081	36824	EL. Box Flat Bar for H300, H330, H350	P4618	77596	Switch Washer A310 (OMAS) for H300, H330, H350	R6864

Parts Breakdown

Model MS-IT-0300-H 13655

Model MS-IT-0330-H 13656

Model MS-IT-0350-PM 13657

Item No.	Description	Position	Item No.	Description	Position	Item No.	Description	Position
36892	Washer 17 x 30 x 4 for H300, H330, H350	R6874	19877	Rubber Cap for H300, H330, H350	T1001	37047	Screw TC AUT.D7971 2.9 x 13 for H300, H330, H350	V6276
16972	Washer 5.5 x 19 x 2.5 for H300, H330, H350	R6884	20265	Tierod H-L for H300, H330, H350	T5004	19913	Screw M8x45 for H300, H330, H350	V6331
78576	Washer for H300, H330, H350	R6931	17491	Knife Shaft Assembly H370 for H300, H330, H350	T8024	37061	Screw TE U5739 M8x35 Inox for H300, H330, H350	V6411X
16973	Plate Wheel D. 25 x 9.5 for H300, H330, H350	R8520	24033	Bracket for H300/330 for H300, H330, H350	T8510	37070	Stainless Steel Screw TE U5739 M6x20 for H300, H330, H350	V6449X
19680	Ball 3 17 for H300, H330, H350	S3005	78586	Plastic Bar lg.200 for H300, H330, H350	T9603	37076	Screw TE TRIL.D7976 M6x15 for H300, H330, H350	V6496
17465	Ball 4.76 for H300, H330, H350	S3015	37004	Gauge Plate H-L300 for H300, H330, H350	V3032	37078	S/S Screw TSP U6109 M5x12 for H300, H330, H350	V7013X
36924	Pin M.E. U6875 6 x 30 for H300, H330, H350	S7546	37006	Gauge Plate H/L330 for H300, H330, H350	V3050	17498	Screw TSPEI U5933 M4x10 for H300, H330, H350	V7043
19688	Pin 2*12 for H300, H330, H350	S7552	37017	Screw STTC U6113 M4x30 for H300, H330, H350	V6009	19713	Screw Sharpener for H300, H330, H350	V7710
17475	Pin 8 x 42 for H300, H330, H350	S7583	37023	Screw STEI U5929 M5x5 for H300, H330, H350	V6065	37091	Screw H for H300, H330, H350	V7730
17476	Foot Support Pin D.10 M8 L.37 for H300, H330, H350	S7595	19691	Grub Screw M6*6 for H300, H330, H350	V6066	17503	Screw M5x13 for H300, H330, H350	V7908
19871	Bracket Sharpener HLC for H300, H330, H350	S8809	19692	Screw M6*8 for H300, H330, H350	V6067	19715	Screw Sharpener for H300, H330, H350	V7910
36936	Bracket Tray H/L30-33-35 for H300, H330, H350	S8813	23648	Screw For H350 for H300, H330, H350	V6073	17504	Screw H/L-C for H300, H330, H350	V7915
36937	Bracket for H Series Plate Rod for H300, H330, H350	S8818C	37032	Screw TC 6107 M3x20 for H300, H330, H350	V6201	19717	Screw M6*50 for H300, H330, H350	V7917
19873	EL Box Bracket for H300, H330, H350	S8901	19696	Screw M3.5*12 for H300, H330, H350	V6204	19720	Screw M6 for H300, H330, H350	V7934
36952	Magnet Support for H300, H330, H350	S8991	19699	Screw M4*25 for H300, H330, H350	V6231	19917	Screw BS for H300, H330, H350	V7960
77597	Washer Bracket A310 (OMAS) for H300, H330, H350	S9009	37037	Screw TCEI U5931 M6x16 for H300, H330, H350	V6240X	19724	Screw H for H300, H330, H350	V8001
36955	Discontinued - Switch Support for H300, H330, H350	S9056	19702	Screw M6*25 for H300, H330, H350	V6246	37098	Screw M10x40 for H300, H330, H350	V8012
24158	Pusher Rod Support for H330 for H300, H330, H350	S9226	19704	Screw M10*16 for H300, H330, H350	V6262	19920	Screw M8x30 for H300, H330, H350	V8036

Electrical Schematics

Model MS-IT-0300-H 13655

Model MS-IT-0330-H 13656

Model MS-IT-0350-PM 13657

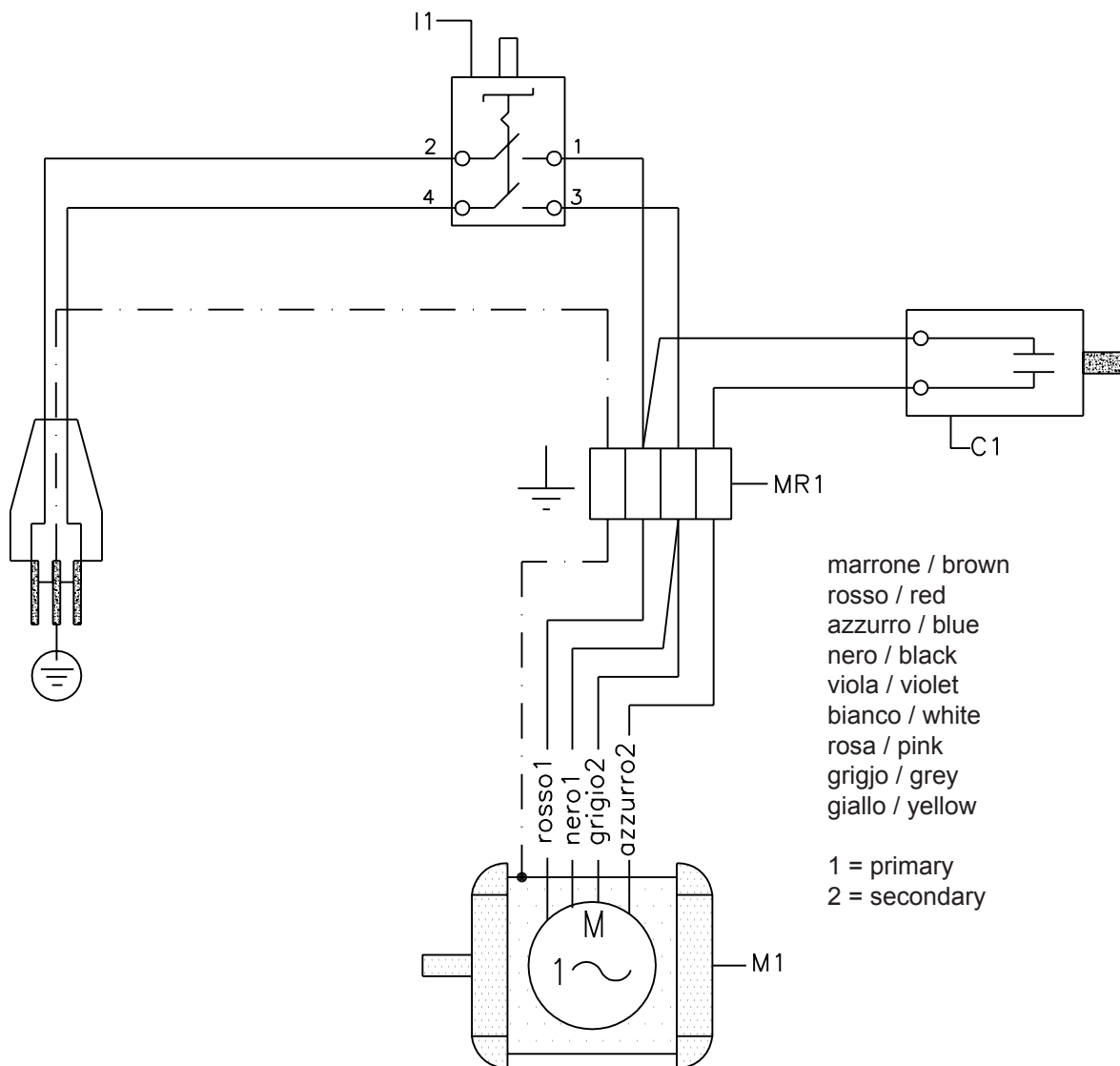

Position	Description
C1	Capacitor 14 μ F 450V
C1	Capacitor 20 μ F 450V (C-120V/60Hz)
I1	Switch
MR1	Terminal Board
M1	Motor



Warranty Registration

Thank you for purchasing an Omcan product. To register your warranty for this product, complete the information below, tear off the card at the perforation and then send to the address specified below. You can also register online by visiting:

Merci d'avoir acheté un produit Omcan. Pour enregistrer votre garantie pour ce produit, complétez les informations ci-dessous, détachez la carte au niveau de la perforation, puis l'envoyer à l'adresse spécifiée ci-dessous. Vous pouvez également vous inscrire en ligne en visitant:

Gracias por comprar un producto Omcan usted. Para registrar su garantía para este producto, complete la información a continuación, cortar la tarjeta en la perforación y luego enviarlo a la dirección indicada a continuación. También puede registrarse en línea en:

www.omcan.com/warrantyregistration.html

For mailing in Canada

Pour postale au Canada

Por correo en Canadá

OMCAN

PRODUCT WARRANTY REGISTRATION

3115 Pepper Mill Court,

Mississauga, Ontario

Canada, L5L 4X5

For mailing in the US

Pour diffusion aux États-Unis

Por correo en los EE.UU.

OMCAN

PRODUCT WARRANTY REGISTRATION

4450 Witmer Industrial Estates, Unit 4,

Niagara Falls, New York

USA, 14305

or email to: service@omcan.com



Purchaser's Information

Name: _____

Address: _____

City: _____ Province or State: _____ Postal or Zip: _____

Country: _____

Dealer from which Purchased: _____

Dealer City: _____ Dealer Province or State: _____

Invoice: _____

Model Name: _____ Model Number: _____

Machine Description: _____

Date of Purchase (MM/DD/YYYY): _____

Would you like to extend the warranty? Yes No

Company Name: _____

Telephone: _____

Email Address: _____

Type of Company:

Restaurant Bakery Deli

Butcher Supermarket Caterer

Institution (*specify*): _____

Other (*specify*): _____

Serial Number: _____

Date of Installation (MM/DD/YYYY): _____

Thank you for choosing Omcan | Merci d'avoir choisi Omcan | Gracias por elegir Omcan



Since 1951 Omcan has grown to become a leading distributor of equipment and supplies to the North American food service industry. Our success over these many years can be attributed to our commitment to strengthen and develop new and existing relationships with our valued customers and manufacturers. Today with partners in North America, Europe, Asia and South America, we continually work to improve and grow the company. We strive to offer customers exceptional value through our qualified local sales and service representatives who provide convenient access to over 3,500 globally sourced products.

Depuis 1951 Omcan a grandi pour devenir un des “leaders” de la distribution des équipements et matériel pour l’industrie des services alimentaires en Amérique du Nord. Notre succès au cours de ces nombreuses années peut être attribué à notre engagement à renforcer et à développer de nouvelles et existantes relations avec nos clients et les fabricants de valeur. Aujourd’hui avec des partenaires en Amérique du Nord, Europe, Asie et Amérique du Sud, nous travaillons continuellement à améliorer et développer l’entreprise. Nous nous efforçons d’offrir à nos clients une valeur exceptionnelle grâce à nos ventes locales qualifiées et des représentants de service qui offrent un accès facile à plus de 3500 produits provenant du monde entier.

Desde 1951 Omcan ha crecido hasta convertirse en un líder en la distribución de equipos y suministros de alimentos en América del Norte industria de servicios. Nuestro éxito en estos años se puede atribuir a nuestro compromiso de fortalecer y desarrollar nuevas relaciones existentes con nuestros valiosos clientes y fabricantes. Hoy con socios de América del Norte, Europa, Asia y América del Sur, que trabajan continuamente para mejorar y crecer la empresa. Nos esforzamos por ofrecer a nuestros clientes valor excepcional a través de nuestro local de ventas y representantes de los servicios que proporcionan un fácil acceso a más de 3,500 productos con origen a nivel mundial.

