



Meat Slicers

*Models MS-IT-0300-G, 0330-G, 0350-G
Items 13641, 13642, 13643
Instruction Manual*



Revised - 11/08/2016



Toll Free: 1-800-465-0234
Fax: 905-607-0234
Email: service@omcan.com
www.omcan.com

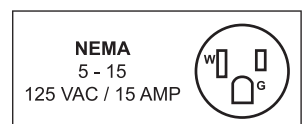

Table of Contents

Model MS-IT-0300-G / Model MS-IT0330-G / Model MS-IT-0350-G

Section	Page
General Information -----	3 - 4
Safety and Warranty -----	4 - 6
Technical Specifications -----	6
Installation -----	7
Operation -----	7
Maintenance -----	7 - 9
Parts Breakdown -----	10 - 17
Notes -----	18
Warranty Registration -----	19



General Information

Omcan Manufacturing and Distributing Company Inc., Food Machinery of America, Inc. dba Omcan and Omcan Inc. are not responsible for any harm or injury caused due to any person's improper or negligent use of this equipment. The product shall only be operated by someone over the age of 18, of sound mind, and not under the influence of any drugs or alcohol, who has been trained in the correct operation of this machine, and is wearing authorized, proper safety clothing. Any modification to the machine voids any warranty, and may cause harm to individuals using the machine or in the vicinity of the machine while in operation.

CHECK PACKAGE UPON ARRIVAL

Upon receipt of an Omcan shipment please inspect for external damage. If no damage is evident on the external packaging, open carton to ensure all ordered items are within the box, and there is no concealed damage to the machine. If the package has suffered rough handling, bumps or damage (visible or concealed), please note it on the bill of lading before accepting the delivery and contact Omcan within 24 hours, so we may initiate a claim with the carrier. A detailed report on the extent of the damage caused to the machine must be filled out within three days, from the delivery date shown in the shipping documents. Omcan has no recourse for damaged products that were shipped collect or third party.

Before operating any equipment, always read and familiarize yourself with all operation and safety instructions.

Omcan would like to thank you for purchasing this machine. It's of the utmost importance to save these instructions for future reference. Also save the original box and packaging for shipping the equipment if servicing or returning of the machine is required.

Omcan Fabrication et distribution Compañie Limité et Food Machinery d'Amérique, dba Omcan et Omcan Inc. ne sont pas responsables de tout dommage ou blessure causé du fait que toute personne ait utilisé cet équipement de façon irrégulière. Le produit ne doit être exploité que par quelqu'un de plus de 18 ans, saine d'esprit, et pas sous l'influence d'une drogue ou d'alcool, qui a été formé pour utiliser cette machine correctement, et est vêtu de vêtements de sécurité approprié. Toute modification de la machine annule toute garantie, et peut causer un préjudice à des personnes utilisant la machine ou des personnes à proximité de la machine pendant son fonctionnement.

VÉRIFIEZ LE COLIS DÈS RÉCEPTION

Dès réception d'une expédition d'Omcan veuillez inspecter pour dommages externes. Si aucun dommage n'est visible sur l'emballage externe, ouvrez le carton afin de s'assurer que tous les éléments commandés sont dans la boîte, et il n'y a aucun dommage dissimulé à la machine. Si le colis n'a subi aucune mauvaises manipulations, de bosses ou de dommages (visible ou cachée), notez-le sur le bond de livraison avant d'accepter la livraison et contactez Omcan dans les 24 heures qui suivent, pour que nous puissions engager une réclamation auprès du transporteur. Un rapport détaillé sur l'étendue des dommages causés à la machine doit être rempli dans un délai de trois jours, à compter de la date de livraison indiquée dans les documents d'expédition. Omcan n'a aucun droit de recours pour les produits endommagés qui ont été expédiés ou cueilli par un tiers transporteur.

General Information

Avant d'utiliser n'importe quel équipement, toujours lire et vous familiariser avec toutes les opérations et les consignes de sécurité.

Omcan voudrais vous remercier d'avoir choisi cette machine. Il est primordial de conserver ces instructions pour une référence ultérieure. Également conservez la boîte originale et l'emballage pour l'expédition de l'équipement si l'entretien ou le retour de la machine est nécessaire.

Omcan Empresa De Fabricacion Y Distribucion Inc. Y Maquinaria De Alimentos De America, Inc. dba Omcan y Omcan Inc. no son responsables de ningun daño o perjuicio causado por cualquier persona inadecuada o el uso descuidado de este equipo. El producto solo podra ser operado por una persona mayor de 18 años, en su sano juicio y no bajo alguna influencia de droga o alcohol, y que este ha sido entrenado en el correcto funcionamiento de esta máquina, y ésta usando ropa apropiada y autorizada. Cualquier modificación a la máquina anula la garantía y puede causar daños a las personas usando la máquina mientras esta en el funcionamiento.

REVISE EL PAQUETE A SU LLEGADA

Tras la recepcion de un envio Omcan favor inspeccionar daños externos. Si no hay daños evidentes en el empaque exterior, Habra el carton para asegurarse que todos los articulos solicitados estén dentro de la caja y no encuentre daños ocultos en la máquina. Si el paquete ha sufrido un manejo de poco cuidado, golpes o daños (visible o oculto) por favor anote en la factura antes de aceptar la entrega y contacte Omcan dentro de las 24 horas, de modo que podamos iniciar una reclamación con la compañía. Un informe detallado sobre los daños causados a la máquina debe ser llenado en el plazo de tres días, desde la fecha de entrega que se muestra en los documentos de envío. Omcan no tiene ningun recurso por productos dañados que se enviaron a recoger por terceros.

Antes de utilizar cualquier equipo, siempre lea y familiarizarse con todas las instrucciones de funcionamiento y seguridad.

Omcan le gustaría darle las gracias por la compra de esta máquina. Es de la mayor importancia para salvar estas instrucciones para futuras consultas. Además, guarda la caja original y el embalaje para el envío del equipo si servicio técnico o devolución de la máquina que se requiere.

Safety and Warranty

SAFETY DEVICES INCORPORATED IN THIS SLICER MUST BE IN THEIR CORRECT OPERATING POSITIONS ANYTIME THE SLICER IS IN USE.

The blade cover ⑥ must be in position over the knife and secured by tightening the screw ⑦. The meat pusher ④ must be used when slicing. To protect your hands from the blade.

When the slicer is not running, the slicer thickness control ② must be set on zero (by turning clockwise) to

Safety and Warranty

prevent the edge of the blade from being exposed. Always **UNPLUG** the power cord before cleaning or moving the slicer.

SLICING

Pull the **product holder** (3) toward you until it stops and place the product to be sliced on the product holder tray. Set the meat pusher against the product and switch on the slicer by pressing the **on-off switch** (9). Adjust the slice thickness by turning the slice thickness control. The numbers on the slice thickness control do not indicate actual measurements but may be used for reference to duplicate slice thickness. Using either the **carriage handle** (13) or the **meat pusher** (4) push the **product holder** (3) back and forth to slice. Always switch-off the slicer and turn the slice thickness control clockwise to zero when not slicing.

CLEANING

This machine must be thoroughly cleaned after each day's operation or anytime it will not be used for an extended period of time. **WARNING: UNPLUG MACHINE POWER CORD AND TURN THE INDEX KNOB FULLY CLOCKWISE BEFORE CLEANING THE SLICER.** Turn the slice deflector (12) for easy cleaning back of the blade. The product holder can be removed for an easy cleaning by rotating its handle counterclockwise (8) Using a mild soap and hot water solution and a clean cloth, wipe all surfaces of the slicer. Thoroughly rinse it with another clean cloth and fresh water. Remove the blade cover by removing the hand knob (7).

WARNING: THE SLICER BLADE IS VERY SHARP USE EXTREME CAUTION WHEN WORKING NEAR THE BLADE. CAREFULLY wash both sides of the blade with the slice thickness control turned fully clockwise. Wash the blade by wiping outward from the center. **ALWAYS** rinse the blade thoroughly using fresh water and a clean cloth. Never use steel pads to clean the blade. Wash and thoroughly rinse the removed components prior to reassembling them. **DO NOT** wash any slicer components in a dishwasher.

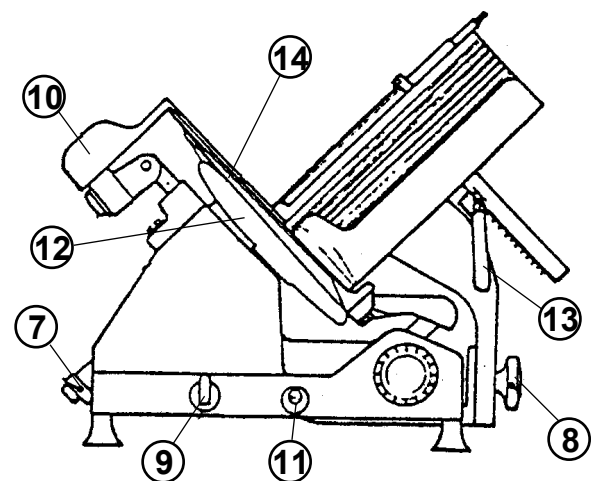
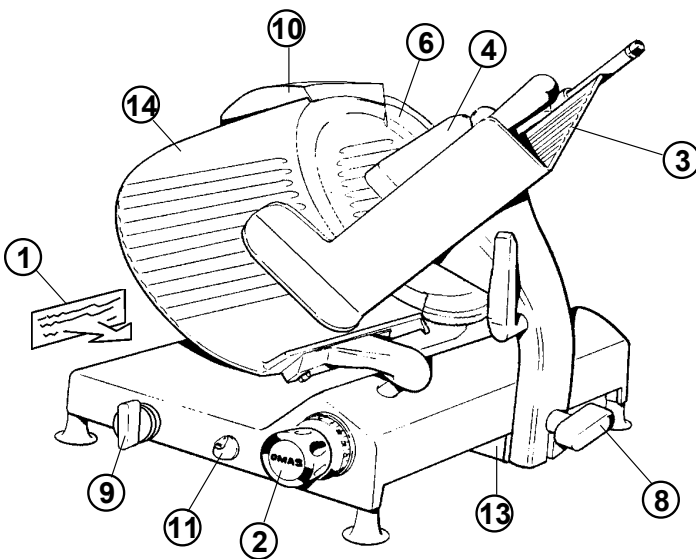

Safety and Warranty

1 YEAR PARTS AND LABOUR BENCH WARRANTY

Within the warranty period, contact Omcan Inc. at 1-800-465-0234 to schedule an Omcan authorized service technician to repair the equipment locally.

Unauthorized maintenance will void the warranty. Warranty covers electrical and part failures, not improper use.

Please see www.omcan.com/warranty.html for complete info.

WARNING:

The packaging components are classified as normal solid urban waste and can therefore be disposed of without difficulty.

In any case, for suitable recycling, we suggest disposing of the products separately (differentiated waste) according to the current norms.

DO NOT DISCARD ANY PACKAGING MATERIALS IN THE ENVIRONMENT!

Technical Specifications

Model	MS-IT-0300-G	MS-IT-0330-G	MS-IT-0350-G
Blade Size	12" / 300mm	13" / 330mm	14" / 350mm
Power	0.35 HP		
RPM	250		
Cutting Size	5.9" x 9.8" / 150 x 249mm	6.5" x 10.6" / 165 x 270mm	7.3" x 11.4" / 185 x 290mm
Cut Thickness	0-0.55" / 0-14mm		
Slicing Volume	8 Hours or more		
Electrical	110V/60Hz/1		
Weight	95 lbs. / 43.1 kgs.	99 lbs. / 44.9 kgs.	100 lbs. / 45.4 kgs.
Dimensions	28.3" x 22.4" x 20" 720 x 570 x 508mm	28.8" x 24" x 20" 730 x 610 x 508mm	30" x 24.8" x 20" 762 x 630 x 508mm
Item Number	13641	13642	13643

Installation

UNPACKING

Immediately after unpacking the slicer, check it for possible shipping damage. If this machine is found to be damaged after unpacking, save the packing material and contact the carrier within 15 days of delivery.

Prior to installation, test the electrical service to assure that it agrees with the specifications on the machine data plate ①.

Operation

ELECTRICAL

Warning: THIS MACHINE IS PROVIDED WITH A PLUG CONNECTED TO PROPERLY GROUNDING PLUG, GROUNDED OUTLET. IF THE RECEPTACLE IS NOT THE PROPER GROUNDING TYPE, CONTACT AN ELECTRICIAN.

Maintenance

CLEANING

This machine must be thoroughly cleaned and sanitized after installation and before being put into service.

ATTENTION: Use protection gloves

BLADE SHARPENING

Your slicer blade will provide long service in normal deli, food store, or commercial kitchen use. However, in high volume applications where it is a practice to sharpen the blade frequently or even daily, the blade will be expended in a shorter time.

Before using sharpener, be sure the front and back side of the knife edge is clean and free of grease. The sharpen knife:

a) be sure that the slicer has been switched off

b) rotate the slice thickness control (item ④) into "O" position, so that the thickness plate (item ⑤) protects the knife fig. 2

Lift up the sharpener cover (item ①) fig. 2

Maintenance

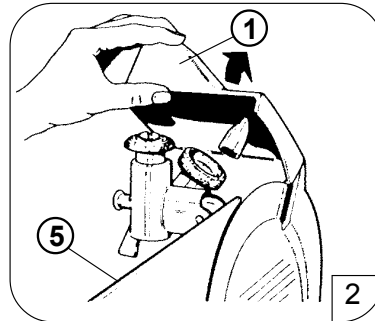
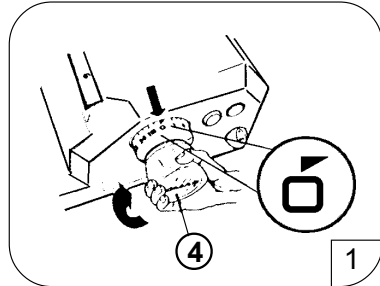

Disengage the pin (item 7) and rotate the sharpener (item 3) fig. 3. So that the sharpener goes into its sharpening position fig. 4.

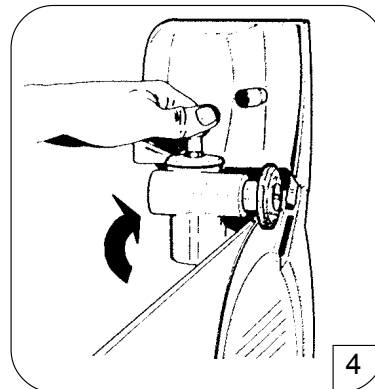
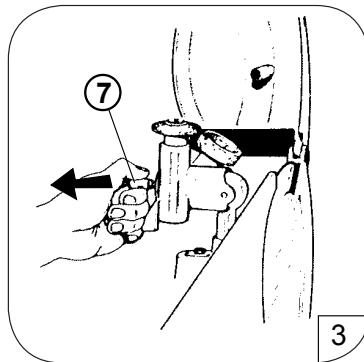

To sharpen, first turning the switch in on position, so that the knife turns, the slowly rotate the lever which lets both stones go in contact with the knife; sharpening and trimming are made in same time fig. 5

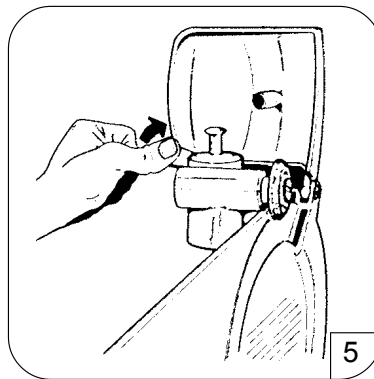

Replace the sharpener to normal horizontal position, by lifting the pin (item 7) and close the cover fig. 6. The grinding stone (item 6), fitted on its pin, can be easily removed, by just drawing it fig. 7. To get a nice sharpening, the grinding stone must be clean and free of grease. The sharpening time depends on the wear of the knife. To get a good result the time needed is 10 to 15 seconds. A longer sharpening reduce the duration of the knife and gives no advantage. Wipe the slicer with a clean damp cloth to remove any grinding particles.

Maintenance

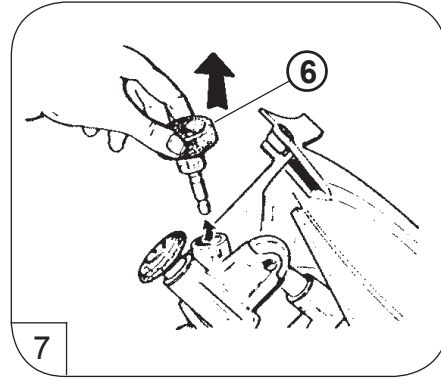
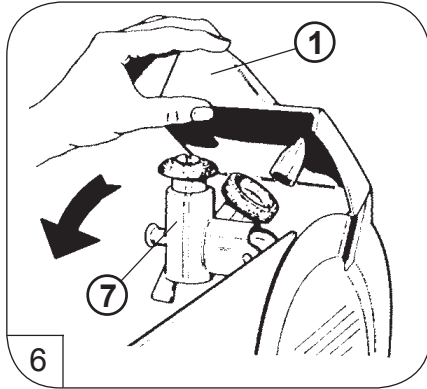

LUBRICATION

The rod on which the product holder slides, which is underneath the slicer, should be lubricated weekly with several drops of oil. Stop the carriage at the end of the stroke nearest the operator and pour the lubricant into the special oiler. **DO NOT** use vegetable oil. Occasionally, the slice thickness plate slide rod should be coated lightly with lubricant. Turn the slice thickness control fully counterclockwise when lubricating this slide rod and then turn it fully clockwise when finished. **DO NOT** lubricate the rod on which the last slice device slides. It must be kept clean but not lubricated. The motor has sealed bearings and requires no lubrication maintenance.

WEAR ADJUSTMENT

After several years of operation and many sharpening of the blade it may become necessary to have the slice thickness plate (14) adjusted closer to the blade.

REFERENCE

Item Number	Model Number	Description	Manufacturer Model Number
13641	MS-IT-0300-G	Meat Slicer Gear Driven 12" / 300mm Blade 0.35 HP / 261 W 110V/60/1 NSF cETL	C300
13642	MS-IT-0330-G	Meat Slicer Gear Driven 13" / 330mm Blade 0.35 HP / 261 W 110V/60/1 NSF cETL	C330
13643	MS-IT-0350-G	Meat Slicer Gear Driven 14" / 350mm Blade 0.35 HP / 261 W 110V/60/1 NSF cETL	C350

Parts Breakdown

Model MS-IT-0300-G 13641

Model MS-IT-0330-G 13642

Model MS-IT-0350-G 13643

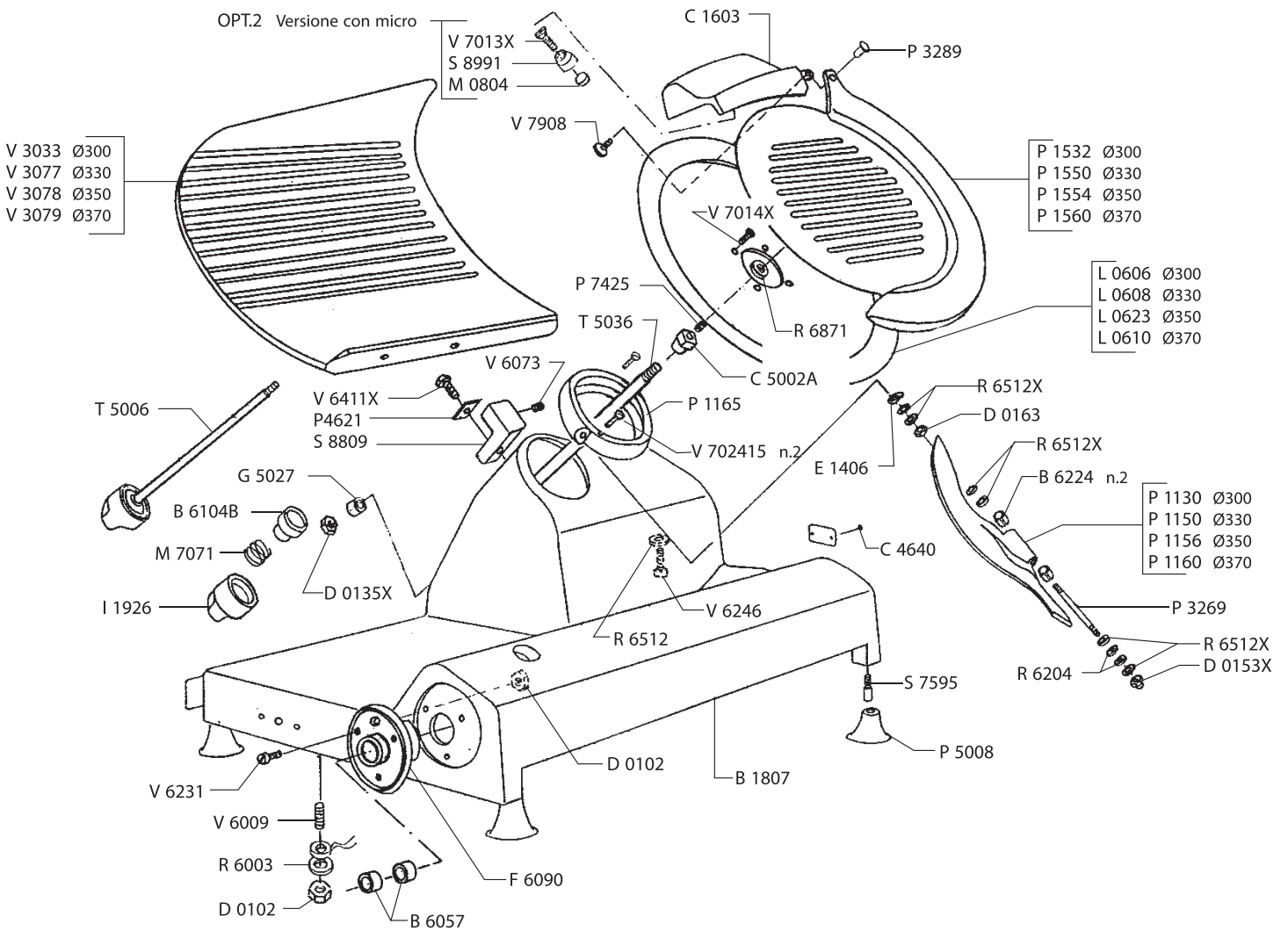

Parts Breakdown

Model MS-IT-0300-G 13641

Model MS-IT-0330-G 13642

Model MS-IT-0350-G 13643

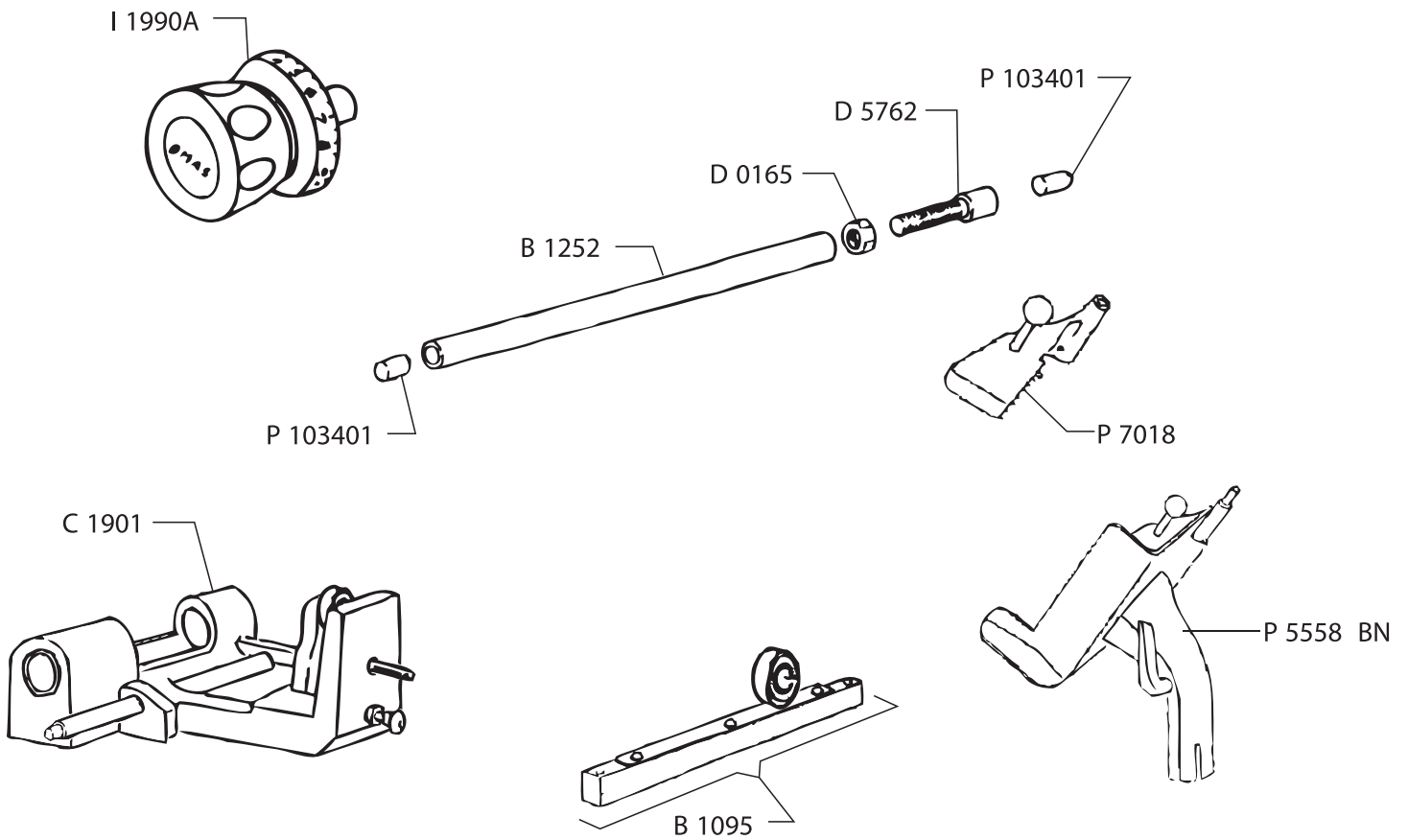

Parts Breakdown

Model MS-IT-0300-G 13641

Model MS-IT-0330-G 13642

Model MS-IT-0350-G 13643



M 8246 - 120V/60Hz-1

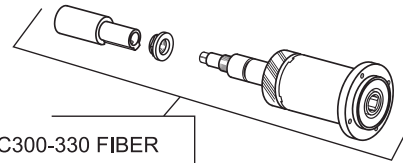

T 8026 C300-330 FIBER
T 8027 C350-370 BRONZE

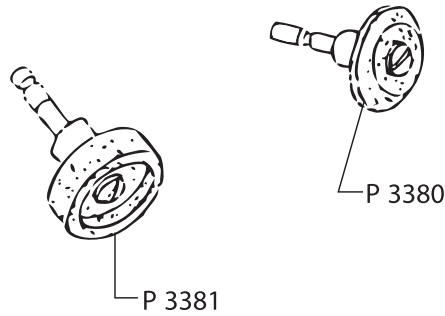

P 3381

P 3380

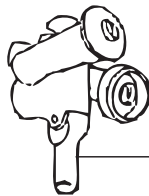

A 1003 - 300-330
A 1006 - 350-370

Parts Breakdown

Model MS-IT-0300-G 13641

Model MS-IT-0330-G 13642

Model MS-IT-0350-G 13643

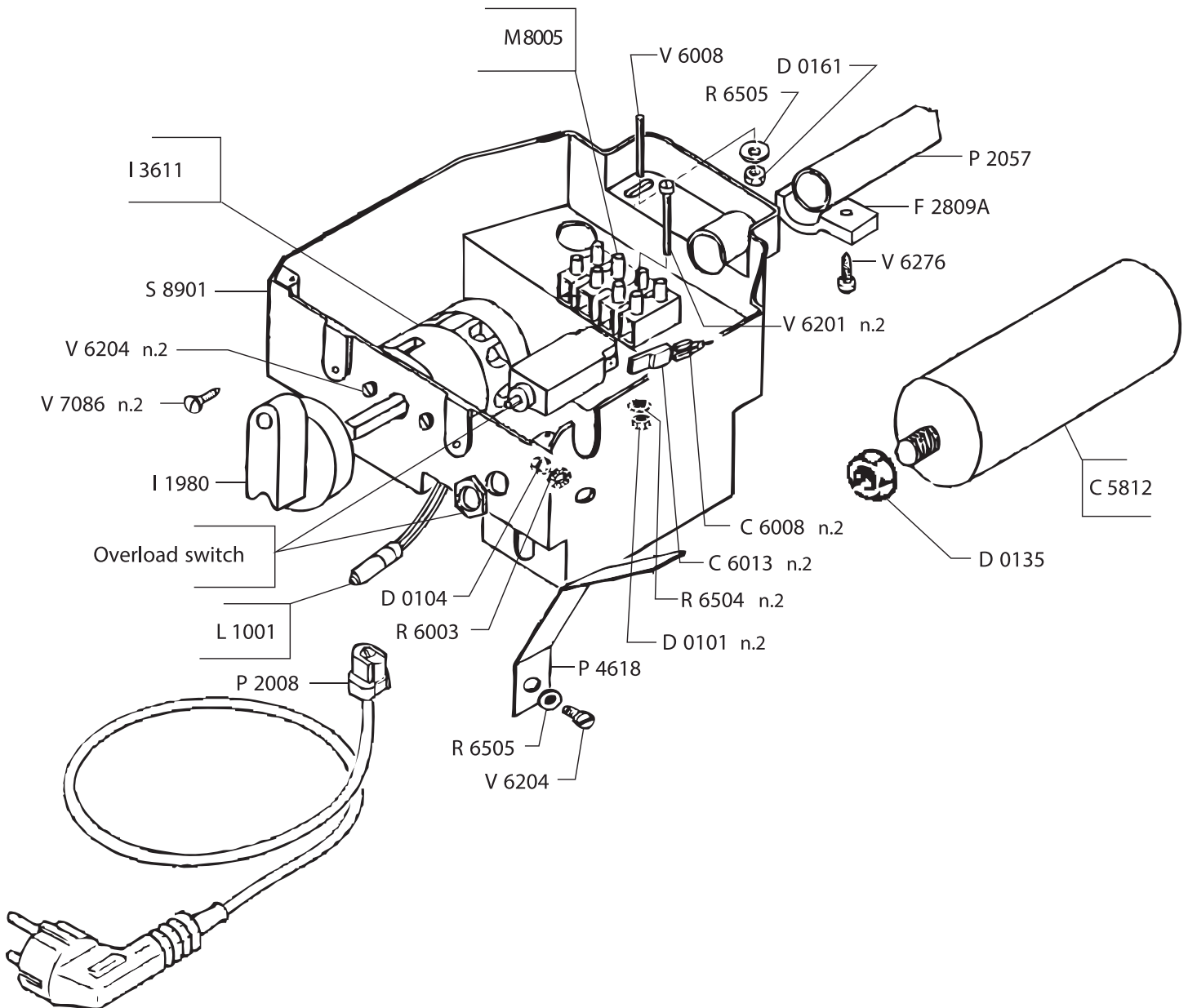

Parts Breakdown

Model MS-IT-0300-G 13641

Model MS-IT-0330-G 13642

Model MS-IT-0350-G 13643



S 3201 - 120V/60Hz-1

Parts Breakdown

Model MS-IT-0300-G 13641

Item No.	Description	Position	Item No.	Description	Position	Item No.	Description	Position
17272	Sharpening Assembly for C300	A1003	36707	Switch Handle for C300	I1980	17455	Washer U6592 4 for C300	R6505
19496	Carriage Rod C-H for C300	B1095	36708	Index Knob Assembly for C300	I1990A	16967	Washer U65926 for C300	R6512
36549	Shock Absorber Rod 12x185 for C300	B1252	16938	Switch and Knob HL C GF 310 for C300	I3611	17457	Washer U6592 6 Stainless Steel for C300	R6512X
78270	Body for C300	B1807	13593	Knife 300mm for C300	L0606	36891	Washer 10.5x26x0.5 Stainless Steel for C300	R6871
17305	Bushing DU 18x20x15 for C300	B6057	19775	Lamp 6.3V.15A for C300	L1001	20457	Circuit Board C for C300	S3201
19630	Bushing Fastener HBC for C300	B6104B	36734	Magnet 12x6 for C300	M0804	17476	Foot Support Pin D.10 M8 L.37 for C300	S7595
36568	DU Bushing 6x8x6 for C300	B6224	19250	Spring 24.8x1.8x15 for C300	M7071	19871	Bracket Sharpener HLC for C300	S8809
16909	Sharpener Cover H-L-C for C300	C1603	20459	Terminal Strip for C300	M8005	19873	EL Box Bracket for C300	S8901
19527	Carriage Assembly C for C300	C1901	20263	Motor 120V/60Hz for C300	M8246	36952	Magnet Support for C300	S8991
36601	Rivet 1.9x5 for C300	C4640	17402	Deflector HM-HP for C300	P1130	16978	Blade Cover Fastener Assembly C for C300	T5006
36606	Bolt H-L-C for C300	C5002A	27888	Pulley Ring for C300	P1165	19887	Blade Cover Fastener C for C300	T5036
16913	Capacitor 14 MF 400V for C300	C5812	36766	Knife Guard for C300	P1532	16981	Knife Shaft Assembly for C300	T8026
36611	Connector L=19 for C300	C6008	17415	Strain Relief for C300	P2008	37005	Gauge Plate for C300	V3033
36612	Connector L=23 for C300	C6013	79238	Cable Sheath Cavoflex cm 60 for C300	P2057	37016	Screw STTC U6113 M4x25 for C300	V6008
19637	Nut M3 for C300	D0101	17422	Pin Deflector H-L-C for C300	P3269	37017	Screw STTC U6113 M4x30 for C300	V6009
19638	Nut M4 for C300	D0102	17423	Pivot Hinged Suport O10x22 for C300	P3289	37032	Screw TC 6107 M3x20 for C300	V6201
36634	Nut U5587 M3.5 for C300	D0104	78584	Assembly Honing Stone Pin H-L-C for C300	P3380	19696	Screw M3.5x12 for C300	V6204
19639	Nut M8 for C300	D0135	17427	Assembly Grinding Stone Pin H-L-C for C300	P3381	19699	Screw M4x25 for C300	V6231
36637	Nut U5589 M8 Stainless Steel for C300	D0135X	36824	EL. Box Flat Bar for C300	P4618	19702	Screw M6x25 for C300	V6246
36640	Domed Nut U5721 M6 Stainless Steel for C300	D0153X	19831	Gauge Plate Flat Bar VS for C300	P4621	37047	Screw TC AUT.D7971 2.9x13 for C300	V6276
36645	Normal Nut U5588 M4 for C300	D0161	16961	Foot H/C/L VS/GL/GF for C300	P5008	37061	Screw TE U5739 M8x35 INOX for C300	V6411X
19644	Nut M6 for C300	D0163	36843	Carriage Plate Assembly for C300	P5558	37078	Stainless Steel Screw TSP U6109 M5x12 for C300	V7013X
36647	Nut U5588 M8 for C300	D0165	17443	End Grip for P4425A and S7702 for C300	P7018	17497	Screw TSP U6109 M5x15 Stainless Steel for C300	V7014X
36661	Carriage Shock Absorber Spacer for C300	D5762	16964	Stud Guard Knife C for C300	P7425	37090	Screw TSP AUT.U6952 4.2x16 for C300	V7086
36681	Cord Holder H-L-C for C300	F2809A	36761	Shock Absorber for C300	P103401	17503	Screw M5x13 for C300	V7908
17349	Handle Flange for C300	F6090	19657	Washer 4 for C300	R6003	37080	Stainless Steel Screw M4x40 U6109 for C300	V702415
36689	Stainless Steel Locknut M8 for C300	G5027	17454	Washer for C300	R6204			
17356	Fastener Handle H-L-C for C300	I1926	36880	Washer U6592 3 for C300	R6504			

Parts Breakdown

Model MS-IT-0330-G 13642

Item No.	Description	Position	Item No.	Description	Position	Item No.	Description	Position
17272	Sharpening Assembly for C330	A1003	17356	Fastener Handle H-L-C for C330	I1926	36880	Washer U6592 3 for C330	R6504
19496	Carriage Rod C-H for C330	B1095	36707	Switch Handle for C330	I1980	17455	Washer U6592 4 for C330	R6505
36549	Shock Absorber Rod 12x185 for C330	B1252	36708	Index Knob Assembly for C330	I1990A	16967	Washer U65926 for C330	R6512
78270	Body for C330	B1807	16938	Switch and Knob HL C GF 310 for C330	I3611	17457	Washer U6592 6 Stainless Steel for C330	R6512X
17305	Bushing DU 18x20x15 for C330	B6057	13598	Knife 330mm for C330	L0608	36891	Washer 10.5x26x0.5 Stainless Steel for C330	R6871
19630	Bushing Fastener HBC for C330	B6104B	19775	Lamp 6.3V.15A for C330	L1001	20457	Circuit Board C for C330	S3201
36568	DU Bushing 6x8x6 for C330	B6224	36734	Magnet 12x6 for C330	M0804	17476	Foot Support Pin D.10 M8 L.37 for C330	S7595
16909	Sharpener Cover H-L-C for C330	C1603	19250	Spring 24.8x1.8x15 for C330	M7071	19871	Bracket Sharpener HLC for C330	S8809
19527	Carriage Assembly C for C330	C1901	20459	Terminal Strip for C330	M8005	19873	EL Box Bracket for C330	S8901
36601	Rivet 1.9x5 for C330	C4640	20263	Motor 120V/60Hz for C330	M8246	36952	Magnet Support for C330	S8991
36606	Bolt H-L-C for C330	C5002A	19805	Deflector HLC for C330	P1150	16978	Blade Cover Fastener Assembly C for C330	T5006
16913	Capacitor 14 MF 400V for C330	C5812	17412	Knife Guard for C330	P1550	19887	Blade Cover Fastener C for C330	T5036
36611	Connector L=19 for C330	C6008	17415	Strain Relief for C330	P2008	16981	Knife Shaft Assembly for C330	T8026
36612	Connector L=23 for C330	C6013	79238	Cable Sheath Cavoflex cm 60 for C330	P2057	78268	Gauge Plate for C330	V3077
19637	Nut M3 for C330	D0101	17422	Pin Deflector H-L-C for C330	P3269	37016	Screw STTC U6113 M4x25 for C330	V6008
19638	Nut M4 for C330	D0102	17423	Pivot Hinged Support O10x22 for C330	P3289	37017	Screw STTC U6113 M4x30 for C330	V6009
36634	Nut U5587 M3.5 for C330	D0104	78584	Assembly Honing Stone Pin H-L-C for C330	P3380	37032	Screw TC 6107 M3x20 for C330	V6201
19639	Nut M8 for C330	D0135	17427	Assembly Grinding Stone Pin H-L-C for C330	P3381	19696	Screw M3.5x12 for C330	V6204
36637	Nut U5589 M8 Stainless Steel for C330	D0135X	36824	EL. Box Flat Bar for C330	P4618	19699	Screw M4x25 for C330	V6231
36640	Domed Nut U5721 M6 Stainless Steel for C330	D0153X	19831	Gauge Plate Flat Bar VS for C330	P4621	19702	Screw M6x25 for C330	V6246
36645	Normal Nut U5588 M4 for C330	D0161	16961	Foot H/C/L VS/GL/GF for C330	P5008	37047	Screw TC AUT.D7971 2.9x13 for C330	V6276
19644	Nut M6 for C330	D0163	36843	Carriage Plate Assembly for C330	P5558	37061	Screw TE U5739 M8x35 INOX for C330	V6411X
36647	Nut U5588 M8 for C330	D0165	17443	End Grip for P4425A and S7702 for C330	P7018	37078	Stainless Steel Screw TSP U6109 M5x12 for C330	V7013X
36661	Carriage Shock Absorber Spacer for C330	D5762	16964	Stud Guard Knife C for C330	P7425	17497	Screw TSP U6109 M5x15 Stainless Steel for C330	V7014X
36681	Cord Holder H-L-C for C330	F2809A	36761	Shock Absorber for C330	P103401	37090	Screw TSP AUT.U6952 4.2x16 for C330	V7086
17349	Handle Flange for C330	F6090	19657	Washer 4 for C330	R6003	17503	Screw M5x13 for C330	V7908
36689	Stainless Steel Locknut M8 for C330	G5027	17454	Washer for C330	R6204	37080	Stainless Steel Screw M4x40 U6109 for C330	V702415

Parts Breakdown

Model MS-IT-0350-G 13643

Item No.	Description	Position	Item No.	Description	Position	Item No.	Description	Position
16899	Sharpening Assembly for C350	A1006	17356	Fastener Handle H-L-C for C350	I1926	16967	Washer U65926 for C350	R6512
19496	Carriage Rod C-H for C350	B1095	36707	Switch Handle for C350	I1980	17457	Washer U6592 6 Stainless Steel for C350	R6512X
36549	Shock Absorber Rod 12x185 for C350	B1252	36708	Index Knob Assembly for C350	I1990A	36891	Washer 10.5x26x0.5 Stainless Steel for C350	R6871
78270	Body for C350	B1807	16938	Switch and Knob HL C GF 310 for C350	I3611	20457	Circuit Board C for C350	S3201
17305	Bushing DU 18x20x15 for C350	B6057	13599	Knife 350mm for C350	L0623	17476	Foot Support Pin D.10 M8 L.37 for C350	S7595
19630	Bushing Fastener HBC for C350	B6104B	19775	Lamp 6.3V.15A for C350	L1001	19871	Bracket Sharpener HLC for C350	S8809
36568	DU Bushing 6x8x6 for C350	B6224	36734	Magnet 12x6 for C350	M0804	19873	EL Box Bracket for C350	S8901
16909	Sharpener Cover H-L-C for C350	C1603	19250	Spring 24.8x1.8x15 for C350	M7071	36952	Magnet Support for C350	S8991
19527	Carriage Assembly C for C350	C1901	20459	Terminal Strip for C350	M8005	16978	Blade Cover Fastener Assembly C for C350	T5006
36601	Rivet 1.9x5 for C350	C4640	20263	Motor 120V/60Hz for C350	M8246	19887	Blade Cover Fastener C for C350	T5036
36606	Bolt H-L-C for C350	C5002A	17404	Deflector for C350	P1156	16983	Knife Shaft Assembly for C350	T8027
16913	Capacitor 14 MF 400V for C350	C5812	17413	Knife Guard for C350	P1554	37010	Gauge Plate for C350	V3078
36611	Connector L=19 for C350	C6008	17415	Strain Relief for C350	P2008	37016	Screw STTC U6113 M4x25 for C350	V6008
36612	Connector L=23 for C350	C6013	79238	Cable Sheath Cavoflex cm 60 for C350	P2057	37017	Screw STTC U6113 M4x30 for C350	V6009
19637	Nut M3 for C350	D0101	17422	Pin Deflector H-L-C for C350	P3269	23648	Screw for C350	V6073
19638	Nut M4 for C350	D0102	17423	Pivot Hinged Support O10x22 for C350	P3289	37032	Screw TC 6107 M3x20 for C350	V6201
36634	Nut U5587 M3.5 for C350	D0104	17427	Assembly Grinding Stone Pin H-L-C for C350	P3381	19696	Screw M3.5x12 for C350	V6204
19639	Nut M8 for C350	D0135	36824	EL. Box Flat Bar for C350	P4618	19699	Screw M4x25 for C350	V6231
36637	Nut U5589 M8 Stainless Steel for C350	D0135X	19831	Gauge Plate Flat Bar VS for C350	P4621	19702	Screw M6x25 for C350	V6246
36640	Domed Nut U5721 M6 Stainless Steel for C350	D0153X	16961	Foot H/C/L VS/GL/GF for C350	P5008	37047	Screw TC AUT.D7971 2.9x13 for C350	V6276
36645	Normal Nut U5588 M4 for C350	D0161	36843	Carriage Plate Assembly for C350	P5558	37061	Screw TE U5739 M8x35 INOX for C350	V6411X
19644	Nut M6 for C350	D0163	17443	End Grip for P4425A and S7702 for C350	P7018	37078	Stainless Steel Screw TSP U6109 M5x12 for C350	V7013X
36647	Nut U5588 M8 for C350	D0165	16964	Stud Guard Knife C for C350	P7425	17497	Screw TSP U6109 M5x15 Stainless Steel for C350	V7014X
36661	Carriage Shock Absorber Spacer for C350	D5762	36761	Shock Absorber for C350	P103401	37090	Screw TSP AUT.U6952 4.2x16 for C350	V7086
30459	Stop Cam for C350	E1406	19657	Washer 4 for C350	R6003	17503	Screw M5x13 for C350	V7908
36681	Cord Holder H-L-C for C350	F2809A	17454	Washer for C350	R6204	37080	Stainless Steel Screw M4x40 U6109 for C350	V702415
17349	Handle Flange for C350	F6090	36880	Washer U6592 3 for C350	R6504			
36689	Stainless Steel Locknut M8 for C350	G5027	17455	Washer U6592 4 for C350	R6505			



Warranty Registration

Thank you for purchasing an Omcan product. To register your warranty for this product, complete the information below, tear off the card at the perforation and then send to the address specified below. You can also register online by visiting:

Merci d'avoir acheté un produit Omcan. Pour enregistrer votre garantie pour ce produit, complétez les informations ci-dessous, détachez la carte au niveau de la perforation, puis l'envoyer à l'adresse spécifiée ci-dessous. Vous pouvez également vous inscrire en ligne en visitant:

Gracias por comprar un producto Omcan usted. Para registrar su garantía para este producto, complete la información a continuación, cortar la tarjeta en la perforación y luego enviarlo a la dirección indicada a continuación. También puede registrarse en línea en:

www.omcan.com/warrantyregistration.html

For mailing in Canada

Pour postale au Canada

Por correo en Canadá

For mailing in the US

Pour diffusion aux États-Unis

Por correo en los EE.UU.

OMCAN

PRODUCT WARRANTY REGISTRATION

3115 Pepper Mill Court,

Mississauga, Ontario

Canada, L5L 4X5

OMCAN

PRODUCT WARRANTY REGISTRATION

4450 Witmer Industrial Estates, Unit 4,

Niagara Falls, New York

USA, 14305

or email to: service@omcan.com



Purchaser's Information

Name: _____

Company Name: _____

Address: _____

Telephone: _____

City: _____ Province or State: _____ Postal or Zip: _____

Email Address: _____

Country: _____

Type of Company:

Restaurant Bakery Deli

Butcher Supermarket Caterer

Institution (*specify*): _____

Other (*specify*): _____

Dealer from which Purchased: _____

Dealer City: _____ Dealer Province or State: _____

Invoice: _____

Model Name: _____ Model Number: _____

Serial Number: _____

Machine Description: _____

Date of Purchase (MM/DD/YYYY): _____

Date of Installation (MM/DD/YYYY): _____

Would you like to extend the warranty? Yes No

Thank you for choosing Omcan | Merci d'avoir choisi Omcan | Gracias por elegir Omcan



Since 1951 Omcan has grown to become a leading distributor of equipment and supplies to the North American food service industry. Our success over these many years can be attributed to our commitment to strengthen and develop new and existing relationships with our valued customers and manufacturers. Today with partners in North America, Europe, Asia and South America, we continually work to improve and grow the company. We strive to offer customers exceptional value through our qualified local sales and service representatives who provide convenient access to over 3,500 globally sourced products.

Depuis 1951 Omcan a grandi pour devenir un des “leaders” de la distribution des équipements et matériel pour l’industrie des services alimentaires en Amérique du Nord. Notre succès au cours de ces nombreuses années peut être attribué à notre engagement à renforcer et à développer de nouvelles et existantes relations avec nos clients et les fabricants de valeur. Aujourd’hui avec des partenaires en Amérique du Nord, Europe, Asie et Amérique du Sud, nous travaillons continuellement à améliorer et développer l’entreprise. Nous nous efforçons d’offrir à nos clients une valeur exceptionnelle grâce à nos ventes locales qualifiées et des représentants de service qui offrent un accès facile à plus de 3500 produits provenant du monde entier.

Desde 1951 Omcan ha crecido hasta convertirse en un líder en la distribución de equipos y suministros de alimentos en América del Norte industria de servicios. Nuestro éxito en estos años se puede atribuir a nuestro compromiso de fortalecer y desarrollar nuevas relaciones existentes con nuestros valiosos clientes y fabricantes. Hoy con socios de América del Norte, Europa, Asia y América del Sur, que trabajan continuamente para mejorar y crecer la empresa. Nos esforzamos por ofrecer a nuestros clientes valor excepcional a través de nuestro local de ventas y representantes de los servicios que proporcionan un fácil acceso a más de 3,500 productos con origen a nivel mundial.

