

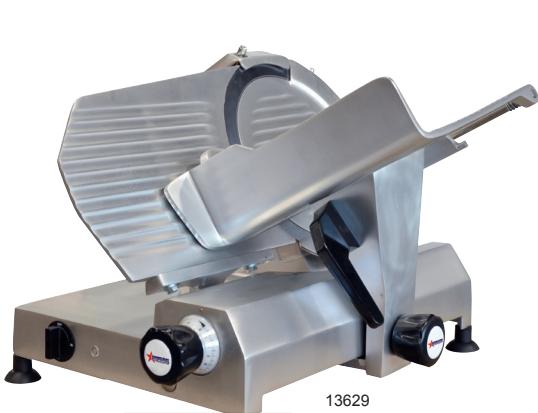

Gravity Meat Slicers

Models MS-IT-0300-IP, 0330-L, 0350-L
Items 13629, 13635, 13637
Instruction Manual



13629



13635

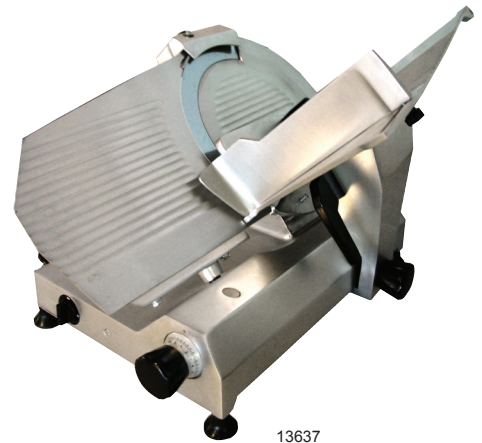

13637



Revised - 09/27/2016



Toll Free: 1-800-465-0234
Fax: 905-607-0234
Email: service@omcan.com
www.omcan.com

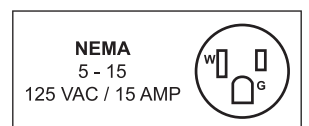

Table of Contents

Models MS-IT-0300-IP / MS-IT-0330-L / MS-IT-0350-L

Section	Page
General Information -----	3 - 4
Safety and Warranty -----	4 - 6
Technical Specifications -----	6 - 8
Installation -----	9 - 10
Maintenance -----	10 - 13
Troubleshooting -----	14 - 15
Parts Breakdown -----	16 - 21
Electrical Schematics -----	22
Warranty Registration -----	23



General Information

Omcan Manufacturing and Distributing Company Inc., Food Machinery of America, Inc. dba Omcan and Omcan Inc. are not responsible for any harm or injury caused due to any person's improper or negligent use of this equipment. The product shall only be operated by someone over the age of 18, of sound mind, and not under the influence of any drugs or alcohol, who has been trained in the correct operation of this machine, and is wearing authorized, proper safety clothing. Any modification to the machine voids any warranty, and may cause harm to individuals using the machine or in the vicinity of the machine while in operation.

CHECK PACKAGE UPON ARRIVAL

Upon receipt of an Omcan shipment please inspect for external damage. If no damage is evident on the external packaging, open carton to ensure all ordered items are within the box, and there is no concealed damage to the machine. If the package has suffered rough handling, bumps or damage (visible or concealed), please note it on the bill of lading before accepting the delivery and contact Omcan within 24 hours, so we may initiate a claim with the carrier. A detailed report on the extent of the damage caused to the machine must be filled out within three days, from the delivery date shown in the shipping documents. Omcan has no recourse for damaged products that were shipped collect or third party.

Before operating any equipment, always read and familiarize yourself with all operation and safety instructions.

Omcan would like to thank you for purchasing this machine. It's of the utmost importance to save these instructions for future reference. Also save the original box and packaging for shipping the equipment if servicing or returning of the machine is required.

Omcan Fabrication et distribution Compañie Limité et Food Machinery d'Amérique, dba Omcan et Omcan Inc. ne sont pas responsables de tout dommage ou blessure causé du fait que toute personne ait utilisé cet équipement de façon irrégulière. Le produit ne doit être exploité que par quelqu'un de plus de 18 ans, saine d'esprit, et pas sous l'influence d'une drogue ou d'alcool, qui a été formé pour utiliser cette machine correctement, et est vêtu de vêtements de sécurité approprié. Toute modification de la machine annule toute garantie, et peut causer un préjudice à des personnes utilisant la machine ou des personnes à proximité de la machine pendant son fonctionnement.

VÉRIFIEZ LE COLIS DÈS RÉCEPTION

Dès réception d'une expédition d'Omcan veuillez inspecter pour dommages externes. Si aucun dommage n'est visible sur l'emballage externe, ouvrez le carton afin de s'assurer que tous les éléments commandés sont dans la boîte, et il n'y a aucun dommage dissimulé à la machine. Si le colis n'a subi aucune mauvaises manipulations, de bosses ou de dommages (visible ou cachée), notez-le sur le bond de livraison avant d'accepter la livraison et contactez Omcan dans les 24 heures qui suivent, pour que nous puissions engager une réclamation auprès du transporteur. Un rapport détaillé sur l'étendue des dommages causés à la machine doit être rempli dans un délai de trois jours, à compter de la date de livraison indiquée dans les documents d'expédition. Omcan n'a aucun droit de recours pour les produits endommagés qui ont été expédiés ou cueilli par un tiers transporteur.

General Information

Avant d'utiliser n'importe quel équipement, toujours lire et vous familiariser avec toutes les opérations et les consignes de sécurité.

Omcan voudrais vous remercier d'avoir choisi cette machine. Il est primordial de conserver ces instructions pour une référence ultérieure. Également conservez la boîte originale et l'emballage pour l'expédition de l'équipement si l'entretien ou le retour de la machine est nécessaire.

Omcan Empresa De Fabricacion Y Distribucion Inc. Y Maquinaria De Alimentos De America, Inc. dba Omcan y Omcan Inc. no son responsables de ningun daño o perjuicio causado por cualquier persona inadecuada o el uso descuidado de este equipo. El producto solo podra ser operado por una persona mayor de 18 años, en su sano juicio y no bajo alguna influencia de droga o alcohol, y que este ha sido entrenado en el correcto funcionamiento de esta máquina, y ésta usando ropa apropiada y autorizada. Cualquier modificación a la máquina anula la garantía y puede causar daños a las personas usando la máquina mientras esta en el funcionamiento.

REVISE EL PAQUETE A SU LLEGADA

Tras la recepcion de un envio Omcan favor inspeccionar daños externos. Si no hay daños evidentes en el empaque exterior, Habra el carton para asegurarse que todos los articulos solicitados estén dentro de la caja y no encuentre daños ocultos en la máquina. Si el paquete ha sufrido un manejo de poco cuidado, golpes o daños (visible o oculto) por favor anote en la factura antes de aceptar la entrega y contacte Omcan dentro de las 24 horas, de modo que podamos iniciar una reclamación con la compañía. Un informe detallado sobre los daños causados a la máquina debe ser llenado en el plazo de tres días, desde la fecha de entrega que se muestra en los documentos de envío. Omcan no tiene ningun recurso por productos dañados que se enviaron a recoger por terceros.

Antes de utilizar cualquier equipo, siempre lea y familiarizarse con todas las instrucciones de funcionamiento y seguridad.

Omcan le gustaría darle las gracias por la compra de esta máquina. Es de la mayor importancia para salvar estas instrucciones para futuras consultas. Además, guarda la caja original y el embalaje para el envío del equipo si servicio técnico o devolución de la máquina que se requiere.

Safety and Warranty

LIMITS OF USE – SAFETY NORMS

These machine were designed and built to slice foodstuff in compliance to the norms of the CE 2006/95/EEC, 93/68/EEC, 2006/42/EEC, 2002/72/EEC, 2004/108 CE, REG 1935/2004/EEC, 2002/95/CE (RoHS) and to the following regulations EN1974, EN ISO12100-1, EN ISO12100-2, EN 294, EN60204-1, EN60335-1, EN60335-2-64.

Safety and Warranty

GENERAL SAFETY REGULATIONS

The slicers must be used only by suitably trained personnel. Furthermore, this personnel must have read this manual carefully. In particular, please comply to the following instructions:

- Install the machine according to the instructions contained in the “Installation” section;
- Do not modify nor exclude the mechanical and electrical safety devices;
- Do not use the machine with improvised connections, or provisional or non insulated cables;
- Check the power cable and gland plate on the machine body regularly and when necessary have them replaced by qualified personnel;
- In case of anomalies, defective operation, incorrect movement, unusual noise, etc stop the machine immediately;
- Before cleaning or servicing, disconnect the machine from the mains;
- Always use scratch-proof and non-slip gloves during cleaning or maintenance;
- Lay or remove the goods to be sliced on the sliding plate only when the latter is completely pushed back and the thickness control knob positioned to 0;
- To move the carriage tray when slicing, use the handle or the product grip handle;
- For extraordinary maintenance (to replace the sharpener wheels, the blade, or others) please contact the manufacturer or qualified and duly authorized personnel;
- Avoid running the slicers with no product on it;
- The slicers are equipped with a ventilated motor. Extended continual use is not recommended. Let the motor cool down after 30 minutes of use.

1 YEAR PARTS AND LABOR BENCH WARRANTY

Within the warranty period, contact Omcan Inc. at 1-800-465-0234 to schedule a drop off to either an Omcan authorized service depot in the area, or to an Omcan Service warehouse to repair the equipment.

Unauthorized maintenance will void the warranty. Warranty covers electrical and part failures, not improper use.

Please see www.omcan.com/warranty.html for complete info.

MANUFACTURER’S WARRANTY AND LIABILITY

The manufacturer’s warranty covering the good functioning of the machines and their compliance to the service for which they have been designed depends on the correct application of the instructions contained in this manual. The Manufacturer assumes no liability either direct or indirect deriving from:

- Failure to comply with the instructions contained in this manual;
- Use of the machine by personnel who has not read or fully understood the content of this manual;
- Use not complying to the specific norms currently applicable in the country of installation;
- Unauthorized modifications and/or repairs;
- Use of non original accessories or spare parts;
- Exceptional events.

Safety and Warranty

ENVIRONMENTAL CONDITIONS OF USE

Temperature: from -5 °C a + 40 °C
 Relative humidity: max 95%

OPENING THE BOX

On reception check packaging integrity, otherwise inform the forwarding agent or the area agent immediately.

To unpack the machine, proceed as follows:

- Open the box and remove your copy of the manual of use and maintenance, then proceed according to the instructions found on that manual;
- Lift the machine still wrapped in a transparent polyethylene sheet and extract it from the box;
- Now check the box content and make sure it corresponds to what shown on the external label.

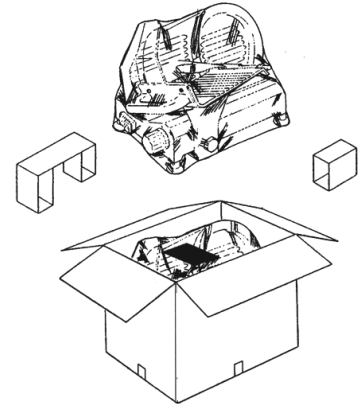

WARNING:

The packaging components (cardboard, polyethylene, and others) are classified as normal solid urban waste and can therefore be disposed of without difficulty.

In any case, for suitable recycling, we suggest disposing of the products separately (differentiated waste) according to the current norms.

DO NOT DISCARD ANY PACKAGING MATERIALS IN THE ENVIRONMENT!

Technical Specifications

Model	MS-IT-0300-IP	MS-IT-0330-L	MS-IT-0350-L
Blade Size	12" / 300mm	13"/330mm	14"/350mm
Cut Thickness	0 - 16mm	0-16mm	0 - 16mm
Cutting Size	11.25" x 9"	11.25" x 9.84"	12.75" x 10.25"
Power	0.50 HP / 0.37 kW	0.50 HP / 0.37 kW	0.50 HP / 0.37 kW
RPM	280	280	286
Electrical	110V / 60Hz / 1	110V/ 60Hz / 1	110V/ 60Hz / 1
Weight	79.3 lbs.	85 lbs.	97 lbs.
Dimension (WDH)	30.31" x 21.25" x 18.30"	30.31" x 21.65" x 18.30"	22.83" x 23" x 19"
Item Numbers	13629	13635	13637

Technical Specifications

The machine is essentially made of a base supporting a circular blade mounted in a tilted position. This blade is driven by an electrical motor to slice foodstuffs. The machine is equipped with a carriage holding a product tray and sliding on a bar mounted under the base top, parallel to the blade. Slice thickness is adjusted by means of a gauge plate mounted in front of the blade. This plate, against which rests the product to be sliced is moved transversely with respect to the blade by a value corresponding to the desired slice thickness. The product is fed to the machine (towards the gauge plate) by gravity. All the machine components are made of polished and anodically oxidized aluminium alloy, of stainless steel and food grade plastic material. The blade is driven by an electrical motor, transmission is by means of a longitudinally grooved belt. The machine is started and stopped by a control button or switch provided with auxiliary circuit preventing accidental restarts after an outage. Some of the machine models have a user-friendly and safe built-in blade sharpener.

ELECTRICAL SAFETY DEVICE

- Optional safety micro-switch preventing the motor from starting when the blade guard is removed.

WARNING: RESIDUAL RISKS

Notwithstanding all the possible cautions taken during the design and the construction of the machine, residual risks (cutting) still exist during use or during cleaning or maintenance. Therefore be careful and PAY THE UTMOST ATTENTION to what you are doing. DO NOT use the machine if you are not in perfect psychological and physical conditions. DO NOT ALLOW anyone near the machine when it is in use. ALWAYS wear gloves that can resist cuts or tears when cleaning, lubricating or sharpening the blade. Slice only the products mentioned as sliceable. NEVER try to slice products that have been mentioned as non sliceable.

ACCESSORIES

If not otherwise defined at the moment of order, the machines are supplied together with the following:

- Instructions manual for installation, use and maintenance.

PRODUCTS THAT CAN BE SLICED

- All types of cold cuts (raw, cooked, smoked);
- Meat without bone (raw or cooked, at a temperature not less than + 3 °C);
- Vegetables (all types).

PRODUCTS THAT MUST NOT BE SLICED:

- Frozen or deep-frozen food;
- Food containing bones (meat or fish);
- Any other non-food product;
- Cheese.

Technical Specifications

MAIN COMPONENTS

MS-IT-0300-IP
 MS-IT-0330-L
 MS-IT-0350-L

- | | |
|---------------------------------|--|
| 1. Switch | 10. Blade |
| 2. N.A. | 11. Product Grip Handle |
| 3. Slice Thickness Control Knob | 12. Manufacturer Identification Plate, Machine Data and UE Marks |
| 4. Adjustable Foot | 13. Pusher Plate Extension |
| 5. Carriage Tray Support | 14. N/A |
| 6. Base | 15. Blade Plate Tie-Rod |
| 7. Product Tray | 16. Supply Cord |
| 8. Blade Plate | 17. Gauge Plate |
| 9. Product Grip | 18. Sharpener |

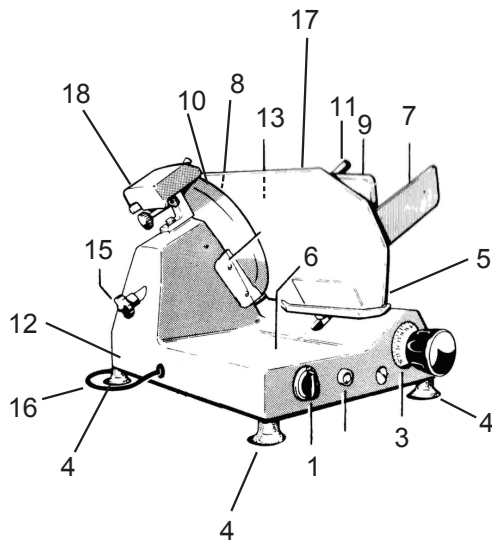

Illustrations may differ from actual machines.

INSTALLING THE MACHINE

Position the machine on a well leveled, smooth and dry top suitably dimensioned to withstand the machine weight.

ELECTRICAL CONNECTION

Install the machine near a compliant outlet derived from a system meeting the local norms.

The user is responsible for ascertaining that the electrical system is suitably dimensioned and functions correctly (supply line, outlet, distribution panel, differential protecting breaker, grounding).

Before carrying out the connection ascertain that the mains characteristics correspondent to those indicated on the machine plate.

COMMANDS

START AND STOP BUTTONS / SWITCHES

- Turn switch or press the white or green button (1) to start running the blade;
- The light turns on to indicate that the machine works correctly;
- Turn switch or press the red or black button to stop the blade.

Slice thickness can be adjusted by turning the graduated knob (4) counterclockwise.

Thickness adjustment range: see paragraph "Technical description and conditions of use".

FUNCTIONING TEST AND BLADE ROTATION DIRECTION

Start the machine and check whether the light is on; make sure that the blade rotates in the direction indicated by the arrow (counterclockwise if you look at the machine from the blade plate side).

- Ascertain that the carriage and the product grip slide correctly;
- Ascertain that the gauge plate works and adjust thickness to desired value.

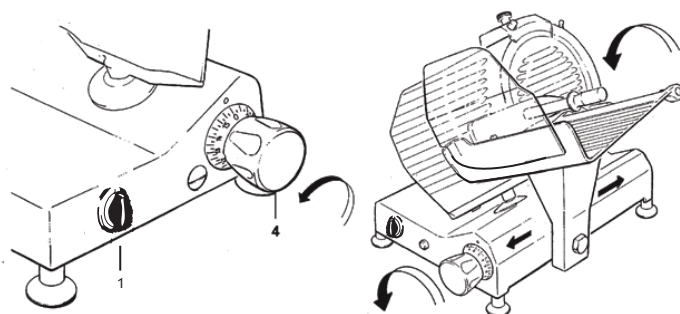

Installation

USING THE MACHINE

LOADING THE PRODUCT ON THE TRAY AND SLICING

- Ascertain that the thickness control knob is correctly positioned to '0';
- Draw back the carriage completely (towards the operator) to loading position;
- Lift the product grip by pulling it away by 10 cm from the blade and put it in rest position;
- Lay the product to be sliced against the guide plate on the operator side;
- Secure by means of the product grip by exerting a slight pressure;
- Adjust the thickness gauge. Start the blade by turning the switch or by pressing on the white or green button;
- Grip the handle affixed onto the plate and start the forward and backward cutting movement. The product travels towards the guide plate by gravity;
- When the product weight or its dimensions do not provide a satisfactory cut by effect of the gravity, use the product grip handle;
- When finished, return the thickness control knob to '0' and draw the carriage back;
- Stop the blade by pressing the black or red button.

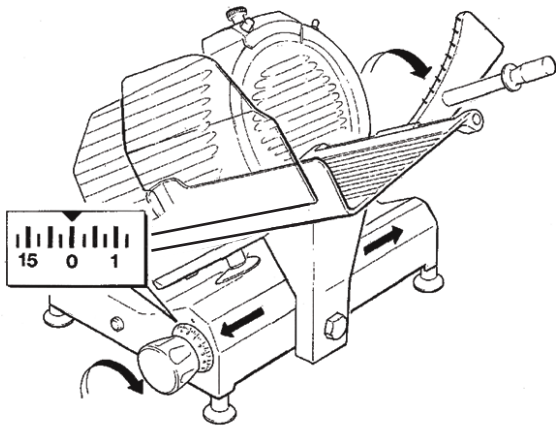

Maintenance

CLEANING THE SLICER

GENERAL

The machine must always be accurately cleaned **at least once a day**, and more often if necessary. **Always use protective gloves.**

DISASSEMBLING THE MACHINE FOR CLEANING

- Disconnect the plug from the mains;
- Turn the gauge plate knob to '0';
- Remove the various components as described in the following paragraphs;
- Unscrew (counterclockwise) the blade guard tie-rod;
- If the blade guard is blocked, press on the rod knob to move it a little;
- Extract the rod and remove the blade guard using for this operation only the side knobs;
- Loosen and remove the two fixing screws with knurled head;
- Remove the slice guard.

To clean the machine body and the blade use only a cloth damped with water and biodegradable lathery detergent having 7-8 pH and at a temperature not below + 30°C. Do not clean the machine by using water or vapor sprays or similar systems.

WARNING:

Use scratch-proof and non-slip gloves to carry out the following operations. Proceed carefully and pay attention to what you are doing. **DANGER OF CUTTING!**

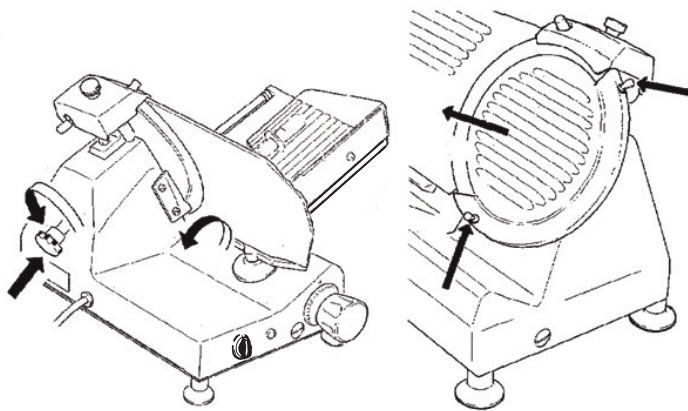

REASSEMBLING THE MACHINE

Proceed as indicated for the previous operations but in reverse order.

GENERAL MAINTENANCE

The operator is allowed to perform the following maintenance operations:

- **Blade sharpening:** regularly (intervals and duration obviously depend on the use of the machine, time of use and type of product sliced).
- **Lubrication of carriage sliding guides:** once a week.
- **Lubrication of product grip sliding bar:** once a week.
- **Adjustment of motor belt tension:** as required.
- **Checking the power supply cord conditions and of the gland plate:** from time to time.

Maintenance

WARNING

Maintenance must always be carried out when the **machine is disconnected from the mains** and if no other position is specifically required, with the thickness control knob on '0'.

The following maintenance operations are to be entrusted only to **personnel authorized by the manufacturer**:

- Replacing the blade;
- Replacing the sharpener stones;
- Replacing the motor transmission belt;
- Replacing electrical system components under the machine base;
- Repairing structural parts, repairing the components under the base.

BLADE SHARPENING

Before proceeding, clean the machine accurately as explained in the previous paragraphs.

WARNING

Sharpening can be done only up to 12 mm of the blade diameter value. **Beyond this value, the BLADE MUST BE REPLACED ONLY by personnel AUTHORIZED BY THE MANUFACTURER.**

SHARPENING VERSIONS WITH BUILT-IN SHARPENER

To sharpen the blade periodically as soon as the cutting capacity decreases. Please proceed as per the following instructions:

1. After disconnecting from the mains, clean the blade accurately using denaturized alcohol to degrease it;
2. Loosen the knob (1) and turn the sharpener (2) by 180° and insert the wheels on the slicer blade. Re lock the knob (1);
3. Operate the switch (3) and press the button (4);
4. Allow the blade to rotate for about 30 to 40 seconds then use the switch (3) to stop it. Brush a pencil lightly on the external side of the blade to check for a slight spud;

We advise performing this operation with the utmost care as the blade is extremely sharp.

5. If some spud is found, operate the switch (3) again for 3 to 4 seconds by pressing the buttons 4 and 5 at the same time;

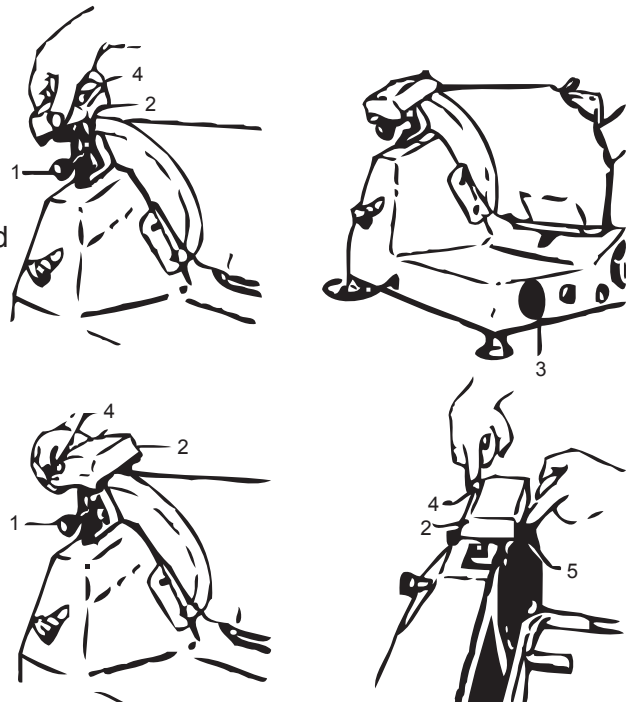

Maintenance

DO NOT PROLONG THIS OPERATION BEYOND THE FEW SECONDS MENTIONED OTHERWISE THE BLADE EDGE WILL WARP.

6. After completing sharpening, we advise cleaning the wheels using a small brush and alcohol;
7. Now return the sharpener to its original position.

LUBRICATION

Carriage sliding guides product grip (once a week)

Use the Omcan oil #27336, otherwise use white Vaseline oil. DO NOT USE VEGETABLE OILS.

- Spread a small quantity of oil on the bar and move the assembly 3 or 4 times;
Clean as required to remove excess of oil.

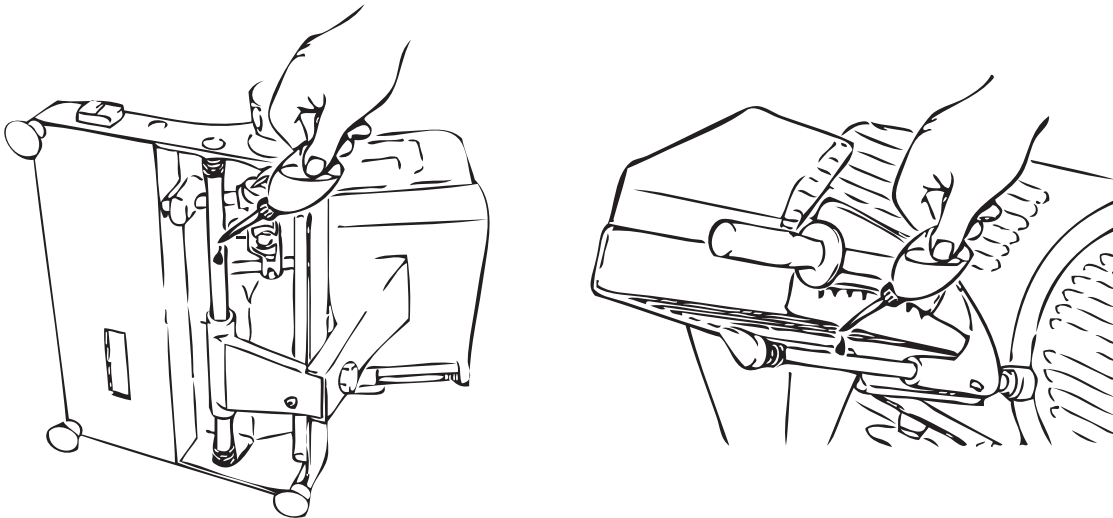

ADJUSTING THE MOTOR BELT TENSION

After a given period of service an unusual noise may occur because of the belt bedding. In this case, tighten the belt-stretcher on the side of the motor under the machine base.

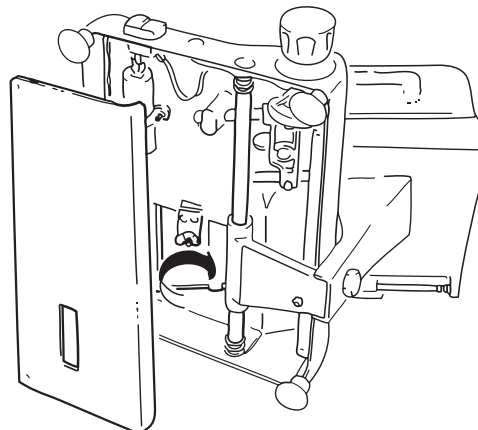

Troubleshooting

The table below indicates the most common problems that may arise during slicing and the necessary remedies.

PROBLEM	POSSIBLE CAUSE	REMEDY
The machine does not start when the white or green button is pressed	No power supply	Ascertain that the plug is correctly inserted
	The blade guard is not correctly positioned	Check
	Defective electrical control circuit	Call technical assistance
When the switch is turned or when the white or green button is pressed, the machine starts, but the white functioning light is not on	Defective indicator	Do not use the machine when the pilot lamp is not on; Call technical assistance
The machine starts, but there are vibrations. The motor is very hot and there is a bad smell	Defective motor or transmission	Do not use the machine, call technical assistance
Under strain, the machine slows down or comes to a stop	Defective transmission	Call technical assistance
Excessive resistance to product slicing	The blade is blunt	Sharpen the blade
The slices are ragged and/or shaped irregularly	The blade is blunt	Sharpen the blade
	The blade is excessively worn out	Call technical assistance
Unsatisfactory blade sharpening	Worn wheels	Replace the wheels; call technical assistance
The product tray does not slide	Guides are insufficiently lubricated	Lubricate
When the switch is turned or when the black or red button is pressed, the machine does not stop	Defective electrical control circuit	Stop the machine, unplug from mains and call technical assistance

DISMANTLING THE SLICER

These machines are made of the following elements:

- Aluminium frame;
- Stainless steel fittings and others;
- Electrical parts and cords;
- Electrical motor;
- Plastic materials, etc.

Whether dismantling is entrusted to third parties or done in-house (in that last case you will have to separate the various materials) please note that disposal of the materials can only be carried out by duly authorized businesses. In any case, please comply to the current norms of your country.

Troubleshooting

WARNING

In any case, to remove the blade and dispose of it, you must contact the manufacturer or personnel duly authorized by the manufacturer. **NEVER DISPOSE OF WASTE IN AREAS WHERE ACCESS IS NOT DELIMITED BY BARRIERS AND FORBIDDEN BY WARNING SIGNS AS THIS WASTE REPRESENTS A SERIOUS DANGER, ESPECIALLY FOR CHILDREN AND ANIMALS. ANY RESPONSIBILITY ARISING OUT OF INCORRECT DISPOSAL FALLS ON THE OWNER.**

Guide to the treatment of waste equipment

This product complied with Directive 2002/96 /EC.



The crossed out wheeled bin symbol on equipment or its packaging indicates that at the end of its working life the equipment should not be treated as general household waste but taken to one of the recycling centres for electrical and electronic equipment run by local authorities. Alternatively, it may be handed over to the reseller when purchasing new equipment of the same type. The user is responsible for consigning the equipment to appropriate collection facilities at the end of its working life or face the penalties provided for by current waste management legislation. Separate collection for subsequent delivery of waste equipment to environmentally-compatible recycling, treatment and disposal facilities to prevent possible negative impacts on the environment and human health whilst encouraging recycling of the product's components. For further information regarding the available collection facilities, please contact your local refuse collection service or the dealer from whom the purchase was made. The manufacturer and/or importer fulfil their obligations concerning environmentally-compatible recycling, treatment and disposal either individually or by joining a collective scheme.

For parts or service call 1-800-465-0234.

REFERENCE

Item Number	Model Number	Description	Manufacturer Model Number
13629	MS-IT-0300-IP	Meat Slicer Belt Driven 12" / 300mm Blade 0.5 HP / 373 W 110V/60/1	300F
13635	MS-IT-0330-L	Meat Slicer Belt Driven 13" / 330mm Blade 0.5 HP / 373 W 110V/60/1	330F
13637	MS-IT-0350-L	Meat Slicer Belt Driven 14" / 350mm Blade 0.5 HP / 373 W 110V/60/1	350F

Parts Breakdown

Model MS-IT-0300-IP 13629

Sold Complete

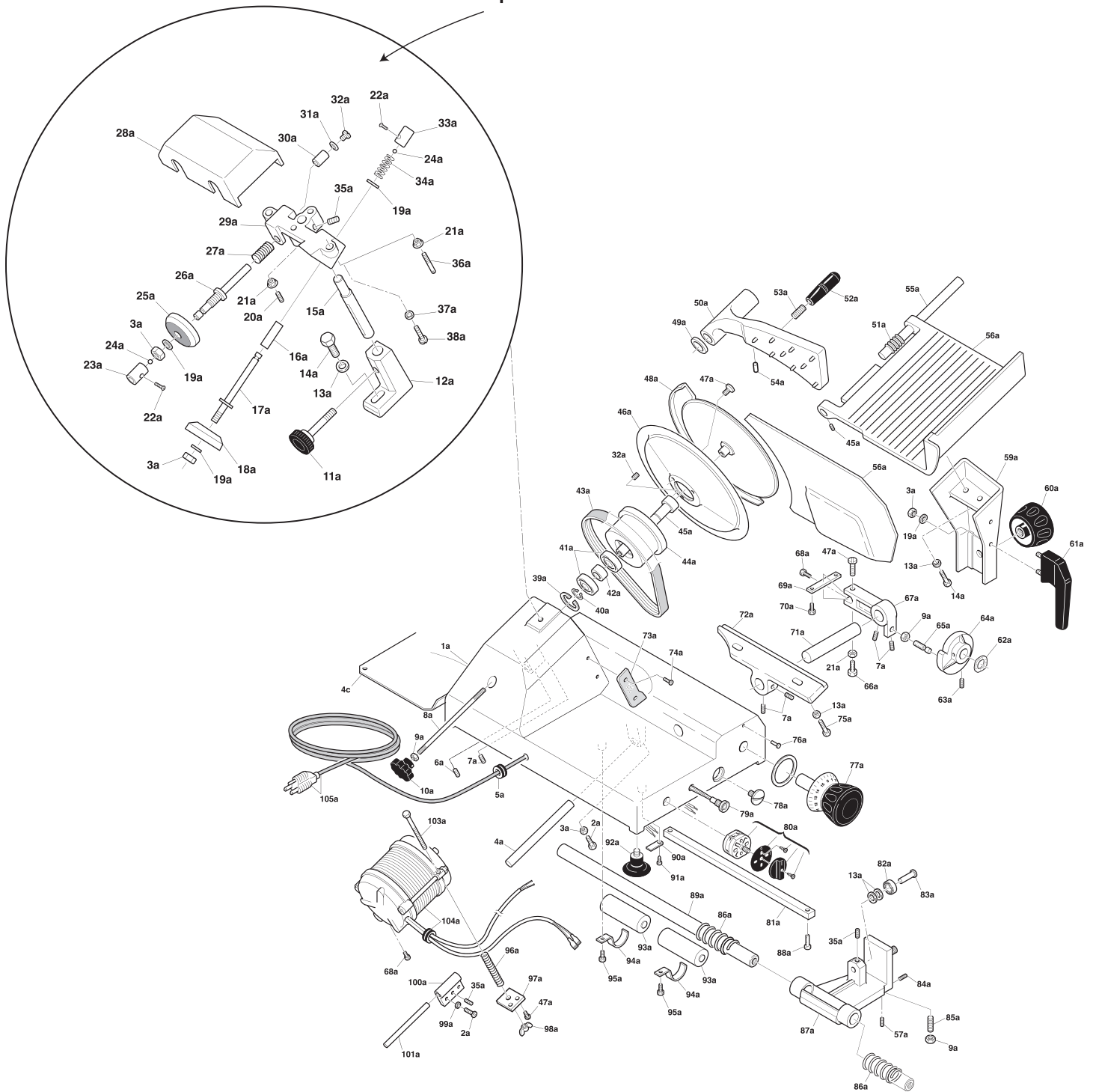



Parts Breakdown

Model MS-IT-0300-IP 13629

Item No.	Description	Position	Item No.	Description	Position	Item No.	Description	Position
34442	Housing for 300F	A1	34477	Washer for 300F	A37	34506	Meat Deflector for 300F	A73
34443	Screw for 300F	A2	34478	Screw TC for 300F	A38	15169	Screw for 300F	A74
34444	Nut for 300F	A3	34479	Clip for 300F	A39	15169	Screw TE for 300F	A75
34445	Guide Plate Pin for 300F	A4	34480	Clip for 300F	A40	34508	Copper Rivet for 300F	A76
34446	Strain Relief for 300F	A5	34481	Bearing for 300F	A41	34028	Index Knob for 300F	A77
34447	Set Screw for 300F	A6	34482	Spacer for 300F	A42	34510	Screw Chrome for 300F	A78
34448	Set Screw for 300F	A7	23741	Belt for 300F	A43	34333	Light for 300F	A79
15163	Tie Rod for 300F	A8	15164	Spindle Pulley for 300F	A44	15195	Switch - On / Off for 300F	A80
34449	Nut for 300F	A9	34483	Bearing and Shaft for 300F	A45	15170	Carriage Rail for 300F	A81
34450	Tie Rod Handle for 300F	A10	13596	Blade for 300F	A46	34513	Bearing for 300F	A82
34451	Sharpener Tie Rod for 300F	A11	34485	Screw TPSV for 300F	A47	34514	Pin for 300F	A83
34452	Sharpener Support Bracket for 300F	A12	15165	Blade Shield for 300F	A48	34515	Set Screw for 300F	A84
34453	Washer for 300F	A13	34486	Rubber Washer for 300F	A49	34516	Set Screw PVC for 300F	A85
34454	Screw TE for 300F	A14	34487	Meat Grip for 300F	A50	19247	Slide Bar Spring for 300F	A86
34455	Sharpener Support Shaft for 300F	A15	34488	Meat Carriage Shaft Spring for 300F	A51	18935	Carriage Support for 300F	A87
34456	Sharpener Pin Spacer for 300F	A16	14893	Meat Grip Handle for 300F	A52	15171	Screw TC for 300F	A88
34457	Sharpener Pin for 300F	A17	14894	Meat Grip Handle Screw for 300F	A53	34517	Carriage Slide Bar for 300F	A89
34458	Sharpening Stone for 300F	A18	34490	Plastic Dowel for 300F	A54	34518	Stop Plate for 300F	A90
34459	Washer for 300F	A19	18936	Meat Carriage Shaft for 300F	A55	15172	Tapping Screw for 300F	A91
34460	Set Screw for 300F	A20	21256	Meat Carriage for 300F	A56	15073	Foot for 300F	A92
34461	Nut for 300F	A21	34491	Set Screw for 300F	A57	34520	Capacitor for 300F	A93
34462	Screw TGS for 300F	A22	34492	Guide Plate for 300F	A58	34521	Capacitor Clamp for 300F	A94
34463	Sharpener Push Button for 300F	A23	34493	Meat Carriage Support for 300F	A59	34522	Screw TC for 300F	A95
34464	Ball Bearing for 300F	A24	15070	Carriage Knob for 300F	A60	34523	Motor Spring for 300F	A96
34465	Sharpening Stone for 300F	A25	15167	Meat Carriage Handle for 300F	A61	34524	Motor Bracket for 300F	A97
34466	Sharpener Pin for 300F	A26	34495	Wavy Washer for 300F	A62	34525	Wing Nut for 300F	A98
34467	Sharpener Pin Spring for 300F	A27	34496	Set Screw for 300F	A63	34526	Washer for 300F	A99
34468	Sharpener Cover for 300F	A28	34497	Cam for 300F	A64	34527	Hinge for 300F	A100
34469	Sharpener Body for 300F	A29	34498	Cam Screw for 300F	A65	34528	Motor Support Shaft for 300F	A101
34470	Sharpener Pin Spacer for 300F	A30	34499	Screw for 300F	A66	34529	Motor Tie Rod for 300F	A103
34471	Washer for 300F	A31	34500	Cam Guide for 300F	A67	15174	Motor for 300F	A104
34472	Screw TC for 300F	A32	34501	Screw TC for 300F	A68	14859	Power Cord for 300F	A105
34473	Sharpener Push Button for 300F	A33	34502	Cam Plate for 300F	A69	37951	Bottom Cover for 300F	C4
34474	Sharpener Pin Spring for 300F	A34	34503	Screw TC for 300F	A70	30445	Cam Assembly for 300F	
34475	Set Screw for 300F	A35	34504	Guide Plate Pin for 300F	A71	76253	Complete Sharpening Assy. for 300F	
34476	Stud Screw for 300F	A36	34505	Guide Plate Support for 300F	A72			

Parts Breakdown

Model MS-IT-0330-L 13635

Sold Complete

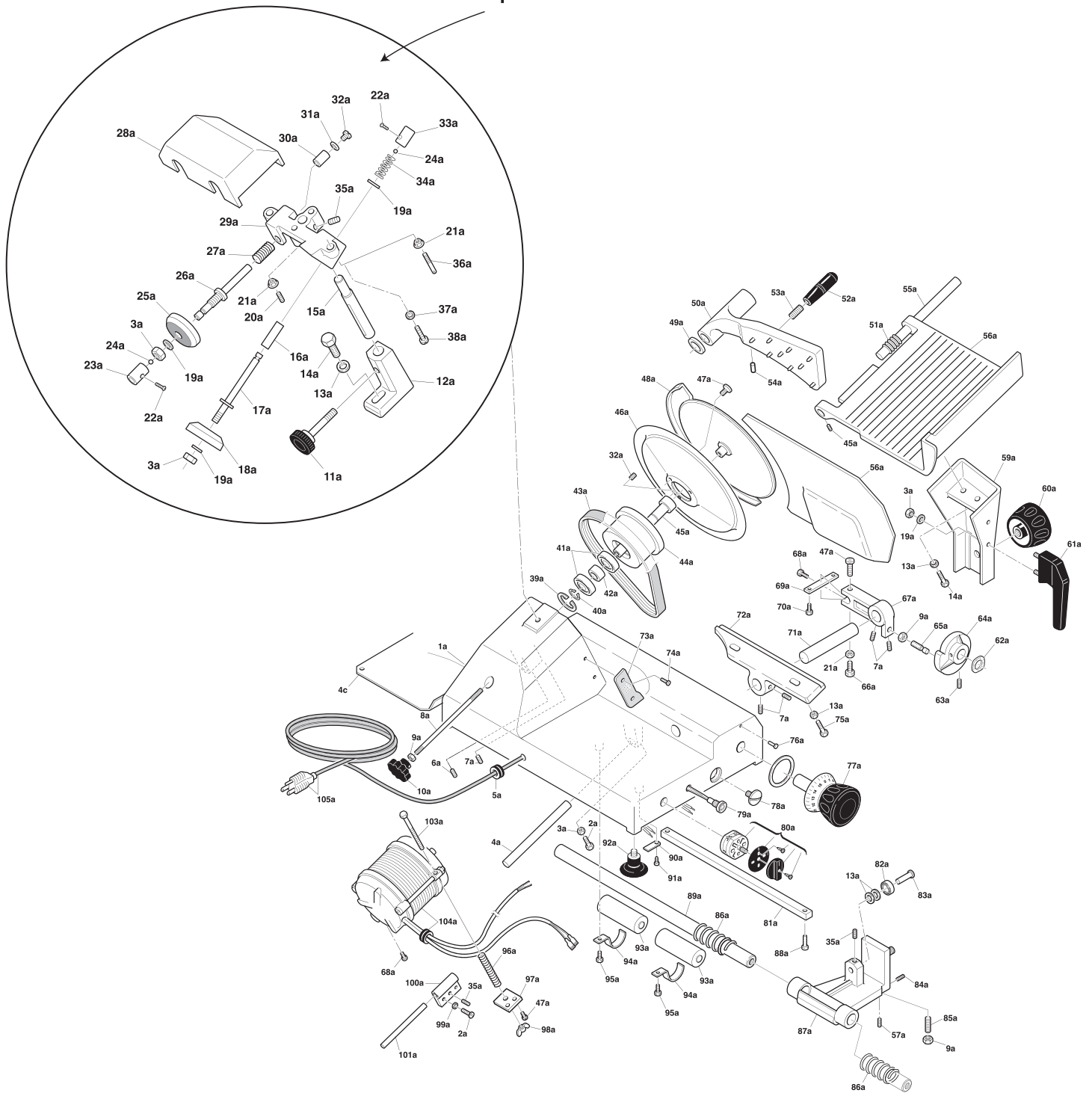

Parts Breakdown

Model MS-IT-0330-L 13635

Item No.	Description	Position	Item No.	Description	Position	Item No.	Description	Position
34636	Housing for 330F	A1	34671	Washer for 330F	A37	34706	Meat Deflector for 330F	A73
34637	Screw for 330F	A2	34672	Screw TC for 330F	A38	34707	Screw for 330F	A74
34638	Nut for 330F	A3	34673	Clip for 330F	A39	34708	Screw TE for 330F	A75
34639	Guide Plate Pin for 330F	A4	34674	Clip for 330F	A40	34709	Copper Rivet for 330F	A76
34640	Strain Relief for 330F	A5	34675	Bearing for 330F	A41	34710	Index Knob for 330F	A77
34641	Set Screw for 330F	A6	34676	Spacer for 330F	A42	34711	Screw Chrome for 330F	A78
34642	Set Screw for 330F	A7	34677	Belt for 330F	A43	34712	Light for 330F	A79
15202	Tie Rod for 330F	A8	34678	Spindle Pulley for 330F	A44	34713	Switch - On / Off for 330F	A80
34643	Nut for 330F	A9	34679	Bearing and Shaft for 330F	A45	34714	Carriage Rail for 330F	A81
34644	Tie Rod Handle for 330F	A10	44857	Blade for 330F	A46	34715	Bearing for 330F	A82
34645	Sharpener Tie Rod for 330F	A11	34681	Screw TPSV for 330F	A47	34716	Pin for 330F	A83
34646	Sharpener Support Bracket for 330F	A12	19284	Blade Shield for 330F	A48	34717	Set Screw for 330F	A84
34647	Washer for 330F	A13	34682	Rubber Washer for 330F	A49	34718	Set Screw PVC for 330F	A85
34648	Screw TE for 330F	A14	34683	Meat Grip for 330F	A50	34719	Slide Bar Spring for 330F	A86
34649	Sharpener Support Shaft for 330F	A15	34684	Meat Carriage Shaft Spring for 330F	A51	34720	Carriage Support for 330F	A87
34650	Sharpener Pin Spacer for 330F	A16	27887	Meat Grip Handle for 330F	A52	34721	Screw TC for 330F	A88
34651	Sharpener Pin for 330F	A17	34685	Meat Grip Handle Screw for 330F	A53	34722	Carriage Slide Bar for 330F	A89
34652	Sharpening Stone for 330F	A18	34686	Plastic Dowel for 330F	A54	34723	Stop Plate for 330F	A90
34653	Washer for 330F	A19	34687	Meat Carriage Shaft for 330F	A55	34724	Tapping Screw for 330F	A91
34654	Set Screw for 330F	A20	34688	Meat Carriage for 330F	A56	34725	Foot for 330F	A92
34655	Nut for 330F	A21	34689	Set Screw for 330F	A57	34726	Capacitor for 330F	A93
34656	Screw TGS for 330F	A22	34690	Guide Plate for 330F	A58	34727	Capacitor Clamp for 330F	A94
34657	Sharpener Push Button for 330F	A23	34691	Meat Carriage Support for 330F	A59	34728	Screw TC for 330F	A95
34658	Ball Bearing for 330F	A24	27886	Carriage Knob for 330F	A60	34729	Motor Spring for 330F	A96
34659	Sharpening Stone for 330F	A25	34693	Meat Carriage Handle for 330F	A61	34730	Motor Bracket for 330F	A97
34660	Sharpener Pin for 330F	A26	34694	Wavy Washer for 330F	A62	34731	Wing Nut for 330F	A98
34661	Sharpener Pin Spring for 330F	A27	34695	Set Screw for 330F	A63	34732	Washer for 330F	A99
34662	Sharpener Cover for 330F	A28	34696	Cam for 330F	A64	34733	Hinge for 330F	A100
34663	Sharpener Body for 330F	A29	34697	Cam Screw for 330F	A65	34734	Motor Support Shaft for 330F	A101
34664	Sharpener Pin Spacer for 330F	A30	34698	Screw for 330F	A66	15203	Motor Tie Rod for 330F	A103
34665	Washer for 330F	A31	34699	Cam Guide for 330F	A67	34735	Motor for 330F	A104
34666	Screw TC for 330F	A32	34701	Screw TC for 330F	A68	14859	Power Cord for 330F	A105
34667	Sharpener Push Button for 330F	A33	34702	Cam Plate for 330F	A69	37449	Bottom Cover for 330F	C4
34668	Sharpener Pin Spring for 330F	A34	34703	Screw TC for 330F	A70	15187	Cam Assembly for 330F	
34669	Set Screw for 330F	A35	34704	Guide Plate Pin for 330F	A71	27539	Complete Sharpening Assy. for 330F	
34670	Stud Screw for 330F	A36	34705	Guide Plate Support for 330F	A72			

Parts Breakdown

Model MS-IT-0350-L 13637

Sold Complete

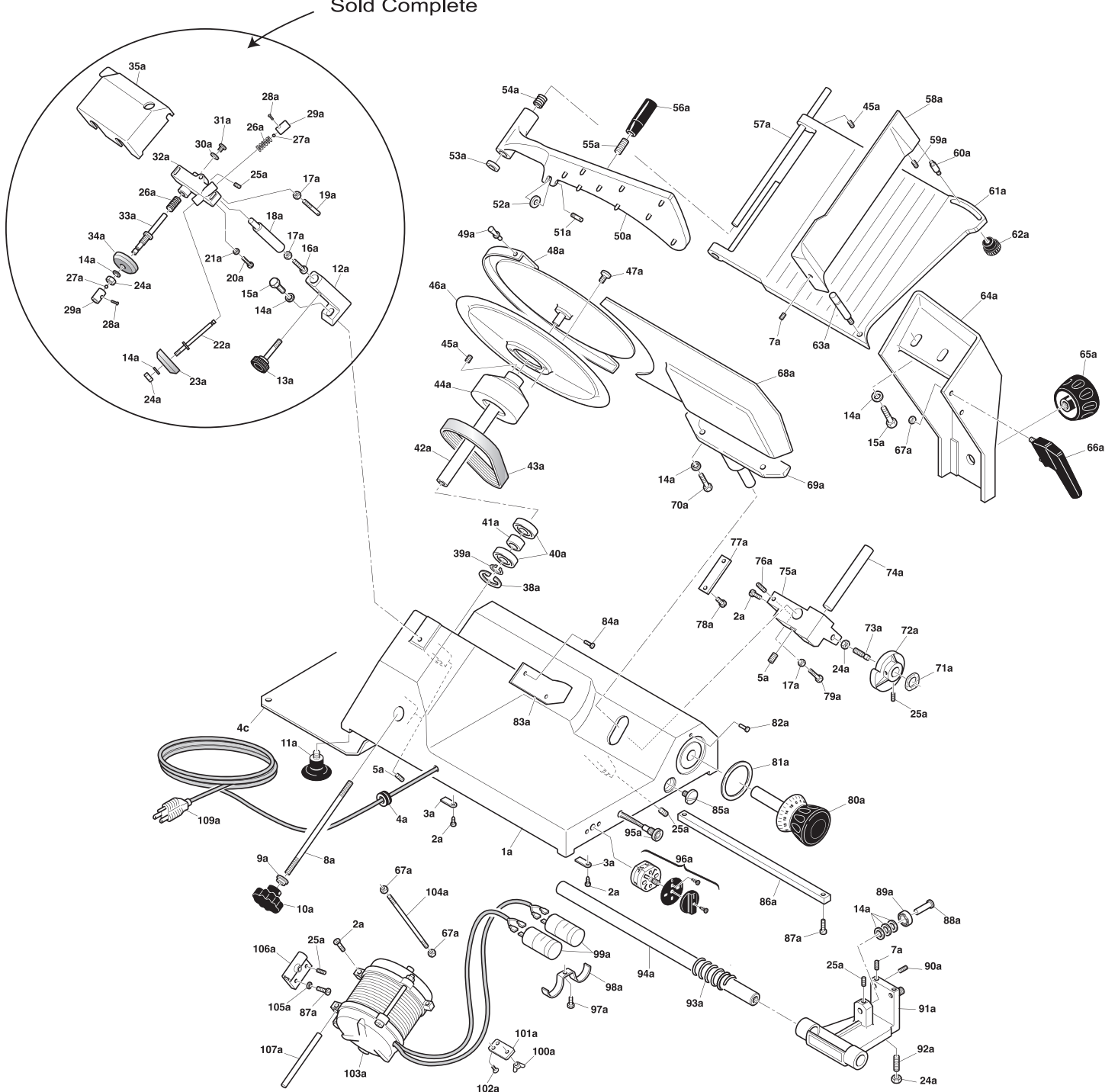



Parts Breakdown

Model MS-IT-0350-L 13637

Item No.	Description	Position	Item No.	Description	Position	Item No.	Description	Position
15204	Housing for 350F	A1	34771	Clip for 350F	A39	34805	Set Screw for 350F	A76
34736	Screw for 350F	A2	34772	Bearing for 350F	A40	34806	Cam Plate for 350F	A77
34737	Stop Plate for 350F	A3	15206	Bearing Spacer for 350F	A41	34807	Screw for 350F	A78
34738	Strain Relief for 350F	A4	34773	Bearing and Shaft for 350F	A42	34808	Screw TC for 350F	A79
34739	Set Screw for 350F	A5	34774	Belt for 350F	A43	34809	Index Knob for 350F	A80
34740	Bushing for 350F	A6	34775	Spindle Pulley for 350F	A44	34810	White Bushing for 350F	A81
34741	Set Screw for 350F	A7	34776	Set Screw for 350F	A45	34811	Copper Rivet for 350F	A82
15205	Tie Rod for 350F	A8	34777	Blade for 350F	A46	34812	Meat Deflector for 350F	A83
34742	Nut for 350F	A9	34778	Screw for 350F	A47	34813	Deflector Screw for 350F	A84
34743	Tie Rod Knob for 350F	A10	34779	Blade Shield for 350F	A48	34814	Screw Chrome for 350F	A85
34744	Foot for 350F	A11	34780	Thumb Screw for 350F	A49	21657	Carriage for 350F	A86
34745	Sharpener Support Bracket for 350F	A12	34781	Meat Grip for 350F	A50	34815	Screw TC for 350F	A87
34746	Sharpener Tie Rod for 350F	A13	34782	Set Screw for 350F	A51	34816	Pin for 350F	A88
34747	Washer for 350F	A14	34783	Washer PVC for 350F	A52	21658	Bearing for 350F	A89
34748	Screw TE for 350F	A15	34784	Rubber Washer for 350F	A53	34817	Set Screw for 350F	A90
34749	Screw TC for 350F	A16	34785	Meat Grip Spring for 350F	A54	15209	Carriage Support for 350F	A91
34750	Washer for 350F	A17	34786	Meat Grip Handle Screw for 350F	A55	34818	Set Screw PVC for 350F	A92
34751	Sharpener Support Pin for 350F	A18	34787	Meat Grip Handle for 350F	A56	34819	Slide Bar Spring for 350F	A93
34752	Sharpener Screw for 350F	A19	34788	Meat Grip Support Shaft for 350F	A57	34820	Carriage Slide Bar for 350F	A94
34753	Screw TC for 350F	A20	34789	Meat Tray Adjustment Plate for 350F	A58	34821	Indicator Light for 350F	A95
34754	Washer for 350F	A21	34790	Set Screw for 350F	A59	34822	Switch - On / Off for 350F	A96
34755	Sharpener Pin for 350F	A22	34791	Set Screw for 350F	A60	34823	Screw TC for 350F	A97
34756	Sharpening Stone for 350F	A23	37448	Meat Tray for 350F	A61	34824	Capacitor Bracket for 350F	A98
34757	Nut for 350F	A24	34792	Sharpener Tie Rod for 350F	A62	15210	Capacitor for 350F	A99
34758	Set Screw for 350F	A25	34793	Pin for 350F	A63	34825	Wing Nut for 350F	A100
34759	Sharpener Spring for 350F	A26	34794	Meat Tray Support Arm for 350F	A64	34826	Motor Bracket for 350F	A101
34760	Ball Bearing for 350F	A27	34795	Carriage Knob for 350F	A65	34827	Screw for 350F	A102
34761	Screw for 350F	A28	15207	Carriage Handle for 350F	A66	34828	Motor for 350F	A103
34762	Sharpener Push Button for 350F	A29	34796	Nut for 350F	A67	31235	Adjustment Rod for 350F	A104
34763	Washer for 350F	A30	34797	Guide Plate for 350F	A68	34829	Washer for 350F	A105
34764	Screw TC for 350F	A31	34798	Guide Plate Support for 350F	A69	34830	Hinge for 350F	A106
34765	Sharpener Body for 350F	A32	34799	Screw TE for 350F	A70	34831	Motor Support Shaft for 350F	A107
34766	Sharpener Pin for 350F	A33	34800	Wavy Washer for 350F	A71	14859	Power Cord 110V for 350F	A109
34767	Sharpening Stone for 350F	A34	34801	Cam for 350F	A72	37449	Bottom Cover for 350F	C4
34768	Sharpener Cover for 350F	A35	34802	Set Screw - Capped for 350F	A73	15211	Complete Pulley Assy. for 350F	
34769	Small Bushing for 350F	A37	15208	Guide Plate Pin for 350F	A74	34804	Complete Cam Assy. for 350F	
34770	Clip for 350F	A38	34803	Cam Guide for 350F	A75	15212	Complete Sharpening Assy. for 350F	

Electrical Schematics

Model MS-IT-0300-IP 13629

Model MS-IT-0330-L 13635

Model MS-IT-0350-L 13637

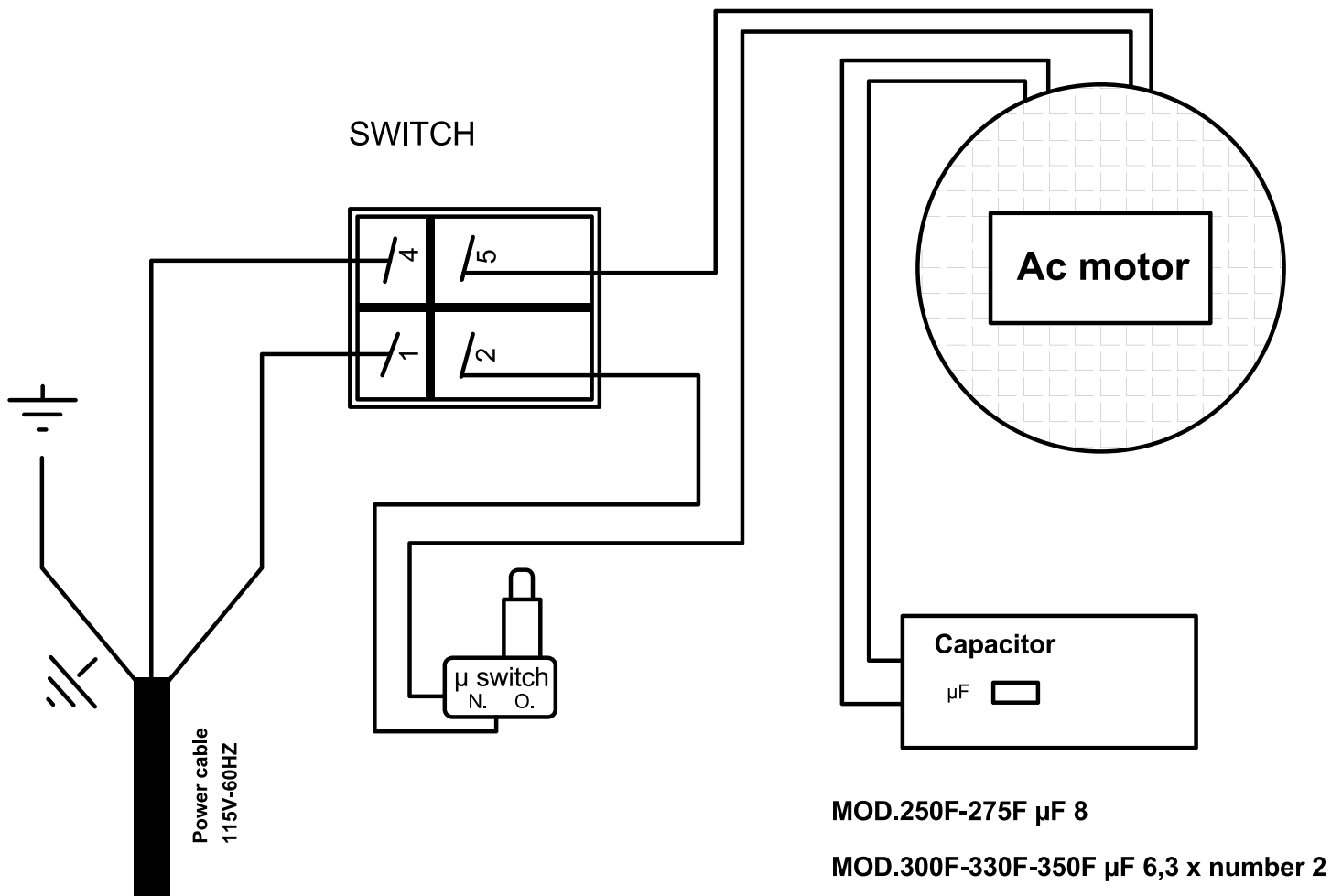



Warranty Registration

Thank you for purchasing an Omcan product. To register your warranty for this product, complete the information below, tear off the card at the perforation and then send to the address specified below. You can also register online by visiting:

Merci d'avoir acheté un produit Omcan. Pour enregistrer votre garantie pour ce produit, complétez les informations ci-dessous, détachez la carte au niveau de la perforation, puis l'envoyer à l'adresse spécifiée ci-dessous. Vous pouvez également vous inscrire en ligne en visitant:

Gracias por comprar un producto Omcan usted. Para registrar su garantía para este producto, complete la información a continuación, cortar la tarjeta en la perforación y luego enviarlo a la dirección indicada a continuación. También puede registrarse en línea en:

www.omcan.com/warrantyregistration.html

For mailing in Canada

Pour postale au Canada

Por correo en Canadá

For mailing in the US

Pour diffusion aux États-Unis

Por correo en los EE.UU.

OMCAN

PRODUCT WARRANTY REGISTRATION

3115 Pepper Mill Court,

Mississauga, Ontario

Canada, L5L 4X5

OMCAN

PRODUCT WARRANTY REGISTRATION

4450 Witmer Industrial Estates, Unit 4,

Niagara Falls, New York

USA, 14305

or email to: service@omcan.com



Purchaser's Information

Name: _____

Address: _____

City: _____ Province or State: _____ Postal or Zip: _____

Country: _____

Dealer from which Purchased: _____

Dealer City: _____ Dealer Province or State: _____

Invoice: _____

Model Name: _____ Model Number: _____

Machine Description: _____

Date of Purchase (MM/DD/YYYY): _____

Would you like to extend the warranty? Yes No

Company Name: _____

Telephone: _____

Email Address: _____

Type of Company:

Restaurant Bakery Deli

Butcher Supermarket Caterer

Institution (specify): _____

Other (specify): _____

Serial Number: _____

Date of Installation (MM/DD/YYYY): _____

Thank you for choosing Omcan | Merci d'avoir choisi Omcan | Gracias por elegir Omcan



Since 1951 Omcan has grown to become a leading distributor of equipment and supplies to the North American food service industry. Our success over these many years can be attributed to our commitment to strengthen and develop new and existing relationships with our valued customers and manufacturers. Today with partners in North America, Europe, Asia and South America, we continually work to improve and grow the company. We strive to offer customers exceptional value through our qualified local sales and service representatives who provide convenient access to over 3,500 globally sourced products.

Depuis 1951 Omcan a grandi pour devenir un des “leaders” de la distribution des équipements et matériel pour l’industrie des services alimentaires en Amérique du Nord. Notre succès au cours de ces nombreuses années peut être attribué à notre engagement à renforcer et à développer de nouvelles et existantes relations avec nos clients et les fabricants de valeur. Aujourd’hui avec des partenaires en Amérique du Nord, Europe, Asie et Amérique du Sud, nous travaillons continuellement à améliorer et développer l’entreprise. Nous nous efforçons d’offrir à nos clients une valeur exceptionnelle grâce à nos ventes locales qualifiées et des représentants de service qui offrent un accès facile à plus de 3500 produits provenant du monde entier.

Desde 1951 Omcan ha crecido hasta convertirse en un líder en la distribución de equipos y suministros de alimentos en América del Norte industria de servicios. Nuestro éxito en estos años se puede atribuir a nuestro compromiso de fortalecer y desarrollar nuevas relaciones existentes con nuestros valiosos clientes y fabricantes. Hoy con socios de América del Norte, Europa, Asia y América del Sur, que trabajan continuamente para mejorar y crecer la empresa. Nos esforzamos por ofrecer a nuestros clientes valor excepcional a través de nuestro local de ventas y representantes de los servicios que proporcionan un fácil acceso a más de 3,500 productos con origen a nivel mundial.

