



Heavy Duty Baking Mixers
Model MX-CN-0020, 0030, 0040, 0060, 0080
Item 43560, 44388, 44389, 44390, 44391
Instruction Manual



Revised - 01/22/2020



Toll Free: 1-800-465-0234
Fax: 905-607-0234
Email: service@omcan.com
www.omcan.com

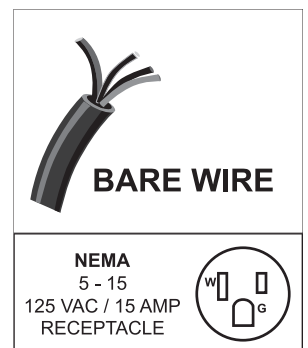

Table of Contents

Model MX-CN-0020 / Model MX-CN-0030 / Model MX-CN-0040
Model MX-CN-0060 / Model MX-CN-0080

Section	Page
General Information -----	3 - 4
Safety and Warranty -----	4 - 5
Technical Specifications -----	6
Operation -----	6 - 8
Maintenance -----	8 - 9
Troubleshooting -----	9 - 10
Parts Breakdown -----	11 - 28
Electrical Schematics -----	29 - 31
Notes -----	32 - 34
Warranty Registration -----	35



General Information

Omcan Manufacturing and Distributing Company Inc., Food Machinery of America, Inc. dba Omcan and Omcan Inc. are not responsible for any harm or injury caused due to any person's improper or negligent use of this equipment. The product shall only be operated by someone over the age of 18, of sound mind, and not under the influence of any drugs or alcohol, who has been trained in the correct operation of this machine, and is wearing authorized, proper safety clothing. Any modification to the machine voids any warranty, and may cause harm to individuals using the machine or in the vicinity of the machine while in operation.

CHECK PACKAGE UPON ARRIVAL

Upon receipt of an Omcan shipment please inspect for external damage. If no damage is evident on the external packaging, open carton to ensure all ordered items are within the box, and there is no concealed damage to the machine. If the package has suffered rough handling, bumps or damage (visible or concealed), please note it on the bill of lading before accepting the delivery and contact Omcan within 24 hours, so we may initiate a claim with the carrier. A detailed report on the extent of the damage caused to the machine must be filled out within three days, from the delivery date shown in the shipping documents. Omcan has no recourse for damaged products that were shipped collect or third party.

Before operating any equipment, always read and familiarize yourself with all operation and safety instructions.

Omcan would like to thank you for purchasing this machine. It's of the utmost importance to save these instructions for future reference. Also save the original box and packaging for shipping the equipment if servicing or returning of the machine is required.

Omcan Fabrication et distribution Compagnie Limitée et Food Machinery d'Amérique, dba Omcan et Omcan Inc. ne sont pas responsables de tout dommage ou blessure causé du fait que toute personne ait utilisé cet équipement de façon irrégulière. Le produit ne doit être exploité que par quelqu'un de plus de 18 ans, sain d'esprit, et pas sous l'influence d'une drogue ou d'alcool, qui a été formé pour utiliser cette machine correctement, et est vêtu de vêtements de sécurité appropriés. Toute modification de la machine annule toute garantie, et peut causer un préjudice à des personnes utilisant la machine ou des personnes à proximité de la machine pendant son fonctionnement.

VÉRIFIEZ LE COLIS DÈS RÉCEPTION

Dès réception d'une expédition d'Omcan veuillez inspecter pour dommages externes. Si aucun dommage n'est visible sur l'emballage externe, ouvrez le carton afin de s'assurer que tous les éléments commandés sont dans la boîte, et il n'y a aucun dommage dissimulé à la machine. Si le colis n'a subi aucune mauvaises manipulations, de bosses ou de dommages (visible ou cachée), notez-le sur le bond de livraison avant d'accepter la livraison et contactez Omcan dans les 24 heures qui suivent, pour que nous puissions engager une réclamation auprès du transporteur. Un rapport détaillé sur l'étendue des dommages causés à la machine doit être rempli dans un délai de trois jours, à compter de la date de livraison indiquée dans les documents d'expédition. Omcan n'a aucun droit de recours pour les produits endommagés qui ont été expédiés ou cueilli par un tiers transporteur.

General Information

Avant d'utiliser n'importe quel équipement, toujours lire et vous familiariser avec toutes les opérations et les consignes de sécurité.

Omcan voudrais vous remercier d'avoir choisi cette machine. Il est primordial de conserver ces instructions pour une référence ultérieure. Également conservez la boîte originale et l'emballage pour l'expédition de l'équipement si l'entretien ou le retour de la machine est nécessaire.

Omcan Empresa De Fabricacion Y Distribucion Inc. Y Maquinaria De Alimentos De America, Inc. dba Omcan y Omcan Inc. no son responsables de ningun daño o perjuicio causado por cualquier persona inadecuada o el uso descuidado de este equipo. El producto solo podra ser operado por una persona mayor de 18 años, en su sano juicio y no bajo alguna influencia de droga o alcohol, y que este ha sido entrenado en el correcto funcionamiento de esta máquina, y ésta usando ropa apropiada y autorizada. Cualquier modificación a la máquina anula la garantía y puede causar daños a las personas usando la máquina mientras esta en el funcionamiento.

REVISE EL PAQUETE A SU LLEGADA

Tras la recepcion de un envio Omcan favor inspeccionar daños externos. Si no hay daños evidentes en el empaque exterior, Habra el carton para asegurarse que todos los articulos solicitados estén dentro de la caja y no encuentre daños ocultos en la máquina. Si el paquete ha sufrido un manejo de poco cuidado, golpes o daños (visible o oculto) por favor anote en la factura antes de aceptar la entrega y contacte Omcan dentro de las 24 horas, de modo que podamos iniciar una reclamación con la compañía. Un informe detallado sobre los daños causados a la máquina debe ser llenado en el plazo de tres días, desde la fecha de entrega que se muestra en los documentos de envío. Omcan no tiene ningun recurso por productos dañados que se enviaron a recoger por terceros.

Antes de utilizar cualquier equipo, siempre lea y familiarizarse con todas las instrucciones de funcionamiento y seguridad.

Omcan le gustaría darle las gracias por la compra de esta máquina. Es de la mayor importancia para salvar estas instrucciones para futuras consultas. Además, guarda la caja original y el embalaje para el envío del equipo si servicio técnico o devolución de la máquina que se requiere.

Safety and Warranty

PRECAUTIONS

- If any item is missing or damaged, please contact the dealer and keep all the packing materials.
- Keep the space on top of the mixer >30cm. Keep the distance between each side/back and the wall >10cm.
- Do not place the machine in a damp place close to heat sources or with direct sunlight.
- Floor or counter must be stable and level.

Safety and Warranty

- Connect or plug the machine power cord to an electrical outlet. Do not share the power socket with other machines.
- Do not use the machine continuously, or its service life may be reduced.
- Do not place the machine in an operating environment where room temperature is a too low (<5°C) or too high (>40°C).

Warning: Do not knead dough at a high speed, do not use sticky ingredients.

CAUTION

- Disconnect or unplug electrical power before cleaning, repairing or moving the machine.
- Keep hands away from moving parts especially the bowl and the safety guard when the mixer is in operation.
- Disconnect or unplug electrical power before changing agitator to avoid personal injury.
- Owners should not permit kids to touch this equipment. Owners should also ensure that no other unauthorized personnel come in contact with this equipment. Unless the operator is adequately trained and supervised there is a possibility of serious injury.
- Do not rinse the entire mixer. Do not use a steel wool or abrasive material to clean the mixer.

1 YEAR PARTS AND LABOUR WARRANTY

Within the warranty period, contact Omcan Inc. at 1-800-465-0234 to schedule an Omcan authorized service technician to repair the equipment locally.

Unauthorized maintenance will void the warranty. Warranty covers electrical and part failures not improper use.

Please see <https://omcan.com/disclaimer> for complete info.

WARNING:

The packaging components are classified as normal solid urban waste and can therefore be disposed of without difficulty.

In any case, for suitable recycling, we suggest disposing of the products separately (differentiated waste) according to the current norms.

DO NOT DISCARD ANY PACKAGING MATERIALS IN THE ENVIRONMENT!

Technical Specifications

Model	MX-CN-0020	MX-CN-0030	MX-CN-0040	MX-CN-0060	MX-CN-0080
Capacity	20 QT / 5 Gal	30 QT / 7.5 Gal	40 QT / 10 Gal	60 QT / 15 Gal	80 QT / 20 Gal
Power	1500W	1800W	2200W	3000W	4000W
Shaft Speed (RPM)	1st - 120 2nd - 272 3rd - 390	1st - 112 2nd - 206 3rd - 351	1st - 120 2nd - 268 3rd - 372	1st - 119 2nd - 275 3rd - 396	
Electrical	110V / 60Hz / 1Ph			220V / 60Hz / 3Ph	
Dimensions	24" x 23.6" x 36.1" 610 x 600 x 918mm	27.1" x 25.2" x 45.1" 688 x 641 x 1145mm	29.3" x 25.2" x 48.2" 744 x 640 x 1225mm	976 x 882 x 1525mm	
Weight	260.1 lbs. / 118 kgs.	385.8 lbs. / 175 kgs.	496 lbs. / 225 kgs.	1040.6 lbs. / 472 kgs.	1080.3 lbs. / 490 kgs.
Item Number	43560	44388	44389	44390	44391

Operation

MACHINE STARTUP



FOR MX-CN-0020, 0030, 0040

Press the (ON button) to start mixing.
 Press the (OFF button) to stop mixing.
 Rotate the (Timer) for timing.
 In case of emergency, press the (OFF button) to stop mixing immediately.
 Replace the beater after shutdown.

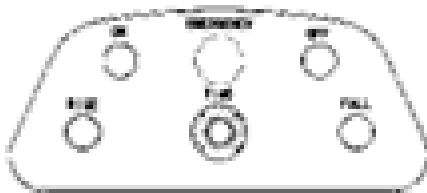

FOR MX-CN-0060, 0080

Press the (ON button) to start mixing.
 Press the (OFF button) to stop mixing.
 Rotate the (Timer) for timing.
 In case of emergency, press the (EMERGENCY button) to stop mixing immediately. Replace the beater after shutdown.
 Press RISE button (or bowl lift button) before you start the machine. Press FALL button (or bowl lower down button) before you stop the machine.

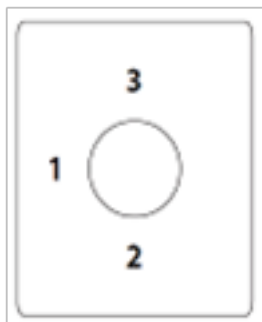

Use the Speed Control handle to adjust speed.

Operation

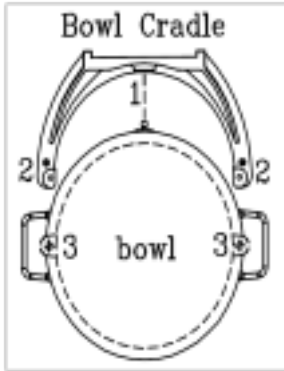

Lift the bowl and slowly position the locking pin into the hole 1 in the cradle, lower the bowl (hole 3 on the bowl) onto the pins located on either of the bowl cradle (hole 2 in the cradle), secure the bowl by pulling each bowl clamp.



To attach the agitator (i.e., beater, hook, whip) to the mixer, slide the agitator slowly upwards onto the mixer shaft fitting the shaft pin through the slot in the agitator, rotate the agitator 45 degree clockwise to secure it onto the mixer shaft, rotate the agitator 45 degree counterclockwise to remove the agitator.

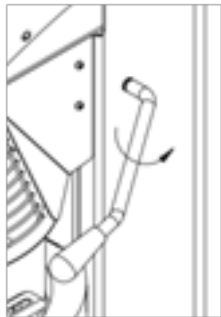

ONLY FOR MX-CN-0020, 0030, 0040

Before starting the mixer, rotate the bowl lift lever up 190 degree counterclockwise. After stopping the mixer, rotate the bowl lift lever down 190 degree clockwise.

INSTRUCTIONS FOR THE AGITATOR

- Flat Beater: for mashing potatoes, mixing cake batter and frostings.
- Wire whip: For fluffy whipped cream, egg whites and frostings.
- Hook: For mixing bread dough and pizza dough.

APPLICABLE SPEEDS OF THE AGITATOR

	1 st SPEED	2 nd SPEED	3 rd SPEED
WIRE WHIP	✓	✓	✓
FLAT BEATER	✓	✓	
HOOK	✓		

Operation

USAGE OF ATTACHMENTS

PRODUCT	WIRE WHIP	FLAT BEATER	HOOK
Raised Donut Dough (65%AR)		✓	
Pizza Dough			✓
Waffle or Hot Cake Batter		✓	
Whipped Cream		✓	
Mashed Potato		✓	
Egg Whites	✓		
Meringue	✓		
Heavy Bread Dough (55%AR)			✓
Bread and Roll Dough (60%AR)			✓
Pizza Dough - Thin (40%AR)			✓
Pizza Dough - Medium (50%AR)			✓
Pizza Dough - Thick (60%AR)			✓
Fondant Icing		✓	
Cake		✓	
Pie Dough		✓	
Pasta, Basic Egg Noodle (5 minutes maximum mix time)			✓

* AR = Absorption Ratio

The above data is for reference only, variances may occur in dough consistency.

Maintenance

CLEANING INSTRUCTIONS

- Clean the mixer prior to using it. Bowl and agitator must be thoroughly cleaned.
- Disconnect or unplug electrical power before cleaning.
- It is important to clean the mixer on a regular basis. Use soft cloth or damp sponge. Do not use a steel wool or abrasive material to clean the mixer. Do not use bleach (sodium hypochlorite) or bleached based cleaner.
- When cleaning the ON/OFF button, power cord or other electrical parts, wipe with dry cloth, do not rinse.
- The factory has applied a generous amount of grease in and on the machine before delivery; generally it can be used for half a year. If you want to add or reapply grease, please open the top cover and inject grease into the grease hole directly.

Maintenance

TRANSPORT AND STORAGE

- Our food mixers are all fixed with bolts in packing cases. During transport, do not place the mixers upside down or horizontal, no squeezing, bumping, rainwater or vibration. During mixer loading and unloading, the angle of inclination cannot exceed 45°.
- The machine should be stored in a ventilated dry warehouse. And must be separated from toxic or corrosive materials.
- When storing and stacking the mixers, read the storage and transport symbols on the packing cases carefully and follow these symbols for stacking.

Troubleshooting

PROBLEM	POSSIBLE CAUSES	ACTION REQUIRED
Mixer will not run.	Power is not connected properly.	Check power connections.
		Test the power socket with another item.
Oil leak.	The sealing ring is damaged.	Replace the sealing ring.
Motor temperature is abnormally high, and rotation speed decreases.	Incorrect or low voltage.	Electrician to check voltage.
	Unit is over loaded.	Reduce the batch size.
	Incorrect mixing speed or incorrect agitator installed.	Follow the instructions to switch the agitator or use the correct speed setting.
Mixer is noisy and runs too hot.	Mixer gear needs more grease.	Reapply grease.
Agitators touching bottom or sides of bowl.	Defective or dented bowl/agitator.	Replace the bowl/agitator.

Note: Omcan reserves the right to modify the product at any time without prior notice. The product pictures are for reference only. Actual product may vary due to product enhancement.

Troubleshooting

REFERENCE

Item Number	Model Number	Description	Manufacturer Model Number
43560	MX-CN-0020	Mixer Heavy Duty 20 QT / 5 Gal with Guard with Timer 2 HP / 1500 W 110V/60/1 cETLus	MC20
44388	MX-CN-0030	Mixer Heavy Duty 30 QT / 7.5 Gal with Guard with Timer 2.7 HP / 2000 W 110V/60/1 cETLus	MC30
44389	MX-CN-0040	Mixer Heavy Duty 40 QT / 10 Gal with Guard with Timer 2.9 HP / 2200 W 220V/60/3 cETLus	MC40
44390	MX-CN-0060	Mixer Heavy Duty 60 QT / 15 Gal with Guard with Timer 4 HP / 3000 W 220V/60/3 cETLus	MC60
44391	MX-CN-0080	Mixer Heavy Duty 80 QT / 20 Gal with Guard with Timer 5 HP / 4000 W 220V/60/3 cETLus	MC80

Parts Breakdown

Model MX-CN-0020 43560

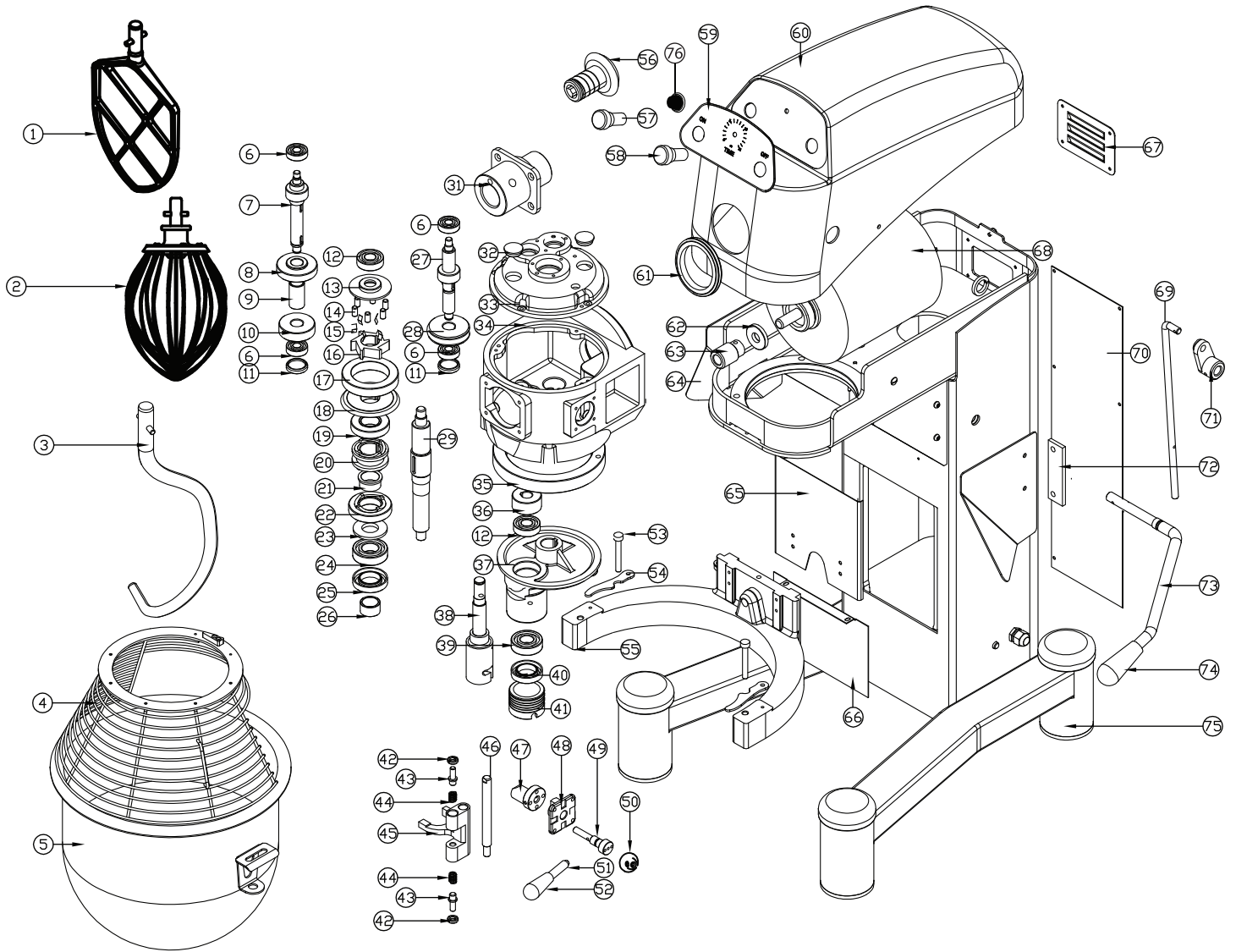

Parts Breakdown

Model MX-CN-0020 43560

Item No.	Description	Position	Item No.	Description	Position	Item No.	Description	Position
64973	Flat Beater for MC20	1	24929	Shaft Worm Gear for MC20	27	64982	Clamp Screw for MC20	53
64974	Wire Whipper for MC20	2	24930	Gear for MC20	28	24908	Press Board for MC20	54
43523	Hook Stainless Steel 304 for MC20	3	64976	Main Shaft for MC20	29	25781	Support for MC20	55
25726	Safety Guard for MC20	4	64977	Thumb Screw for MC20	30	24872	Tapered Gear Wheel for MC20	56
25157	Bowl for MC20	5	24869	Attachment Hub for MC20	31	25773	Red Button for MC20	57
24912	Bearing 6201 for MC20	6	24985	Plug Cover (Steel) for MC20	32	24922	Green Button Round for MC20	58
24913	Mid-Gear Wheel for MC20	7	24895	Transmission Shaft Support for MC20	33	64983	Front Plate for MC20	59
24916	Gear for MC20	8	64978	Gearbox for MC20	34	64984	Top Cover for MC20	60
24917	Bushing for MC20	9	24886	Internal Gear for MC20	35	64985	Hub Ring for MC20	61
24918	Gear for MC20	10	24887	Gear for MC20	36	24921	Oil Seal for MC20	62
24919	Plug Cover for MC20	11	64810	Shaft Holder for MC20	37	25013	Worm Wheel-New for MC20	63
25088	Bearing 6203 for MC20	12	64811	Planetary Shaft for MC20	38	25771	Side Plate for MC20	64
24897	Spacer-Lower for MC20	13	25070	Bearing 6204 for MC20	39	25770	Cover Board for MC20	65
24879	Roller 8x15 for MC20	14	24890	Oil Seal for MC20	40	25785	Cover Board for MC20	66
64975	Spring for MC20	15	64979	Agitator Joint Shaft for MC20	41	25775	Leak Board for MC20	67
24878	Gear for MC20	16	24957	Screw for MC20	42	64986	Motor for MC20	68
24877	Big Gear for MC20	17	24959	Pin Shaft for MC20	43	25799	Connecting Rod for MC20	69
25814	Taper Gear Wheel for MC20	18	24958	Spring for MC20	44	25779	Back Cover Plate for MC20	70
24900	Gear for MC20	19	64980	Fork for MC20	45	64987	Crank Lever for MC20	71
24902	Sleeve for MC20	20	24881	Declutch Shift Shaft for MC20	46	64988	Guide Plate for MC20	72
24901	Bushing for MC20	21	64981	Shaft Bias for MC20	47	64989	Bowl Lift Arm for MC20	73
24903	Claw Type Gear Wheel for MC20	22	24864	Plate-Shifter Index for MC20	48	64990	Rubber Grip for MC20	74
24904	Gasket for MC20	23	25790	Handle-Shifter for MC20	49	64991	Mixer Base for MC20	75
24905	Bearing 6205 for MC20	24	25793	Link Rod for MC20	50	65253	Timer for MC20	76
24907	Oil Seal for MC20	25	25797	Speed Handle for MC20	51			
24906	Bushing for MC20	26	25796	Handle Sleeve M8x58 for MC20	52			

Parts Breakdown

Model MX-CN-0030 44388

Head

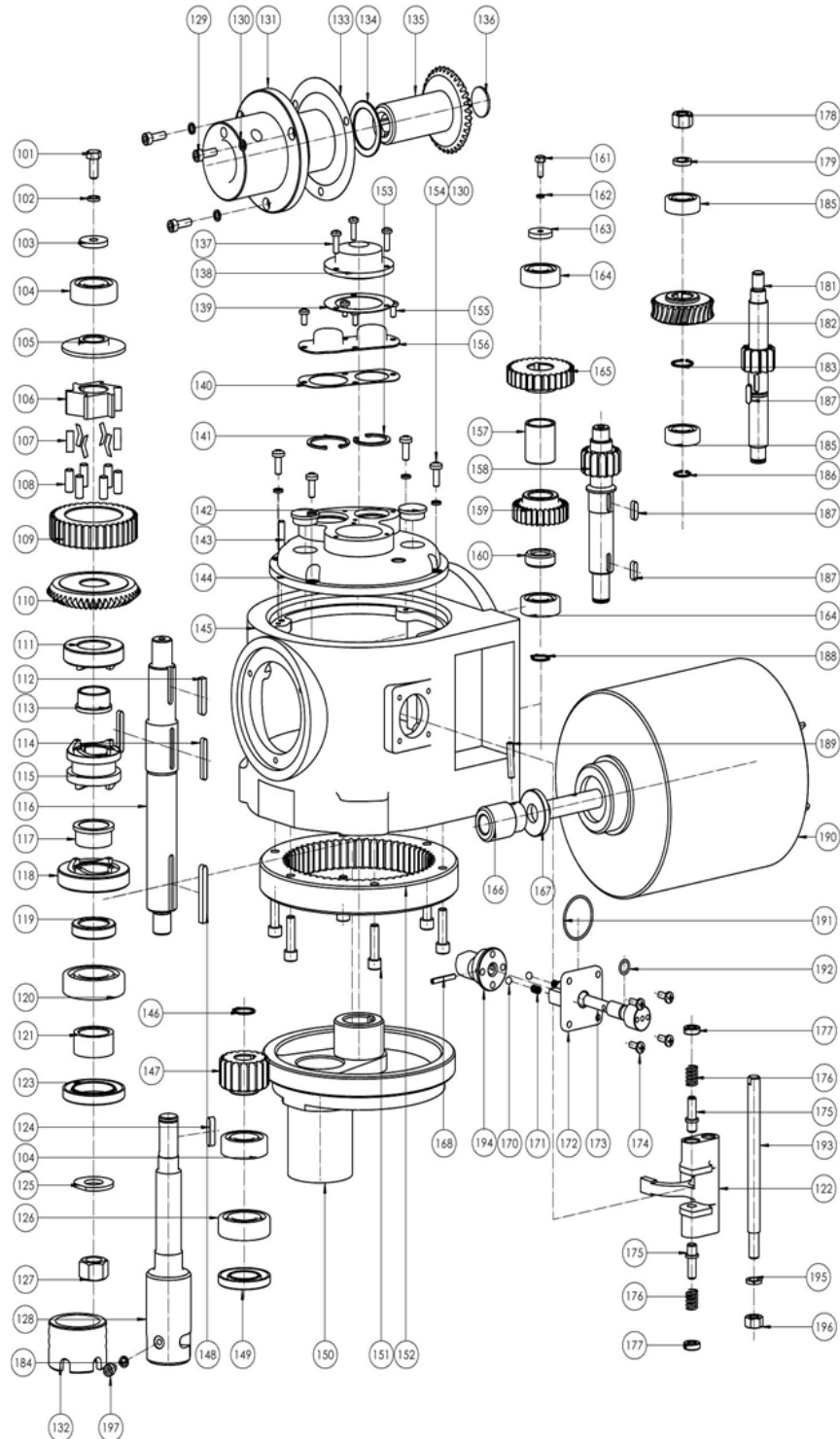

Parts Breakdown

Model MX-CN-0030 44388

Item No.	Description	Position	Item No.	Description	Position	Item No.	Description	Position
67774	Sticker for MC30	1	67809	Support for MC30	45	67828	Bolt M8x20 for MC30	101
67775	Emergency Stop Button for MC30	2	67875	Travel Device Assembly for MC30	46	25096	Spring Washer Φ8 for MC30	102
67776	Hook for MC30	3	24947	Micro Switch for MC30	47	67836	Shaft Retaining Ring for MC30	103
64985	Scraper Seal for MC30	4	61185	Bolt M3x14 for MC30	48	25070	Bearing 6204 for MC30	104
64977	Peg Handle for MC30	5	67810	Flat Washer Φ3 for MC30	49	24987	Spacer-Lower for MC30	105
67777	Elastic Cylindrical Pin 4x20 for MC30	6	67811	Press Board 2 for MC30	50	24989	Gear for MC30	106
67778	Plug for MC30	7	67812	Cover Plate-Down for MC30	51	67837	Coil Spring for MC30	107
67779	Screw Nut M6 for MC30	8	67813	Side Guard Left/Right for MC30	52	24990	Pin Roller for MC30	108
67780	Bolt M6x16 for MC30	9	67814	Davit for MC30	53	24988	Super Machine Parts for MC30	109
67781	Bolt M6x35 for MC30	10	67815	Water Joint for MC30	54	67838	Gear for MC30	110
65370	Stainless Steel Flat Washer Φ6 for MC30	11	67816	Travel Cover for MC30	55	25010	Sleeve for MC30	111
67782	Bolt M8x35 for MC30	12	67817	Crank Lever for MC30	56	67839	Key C6x32 for MC30	112
67783	Stainless Steel Flat Washer Φ8 for MC30	13	67818	Running Capacitor for MC30	57	24901	Bushing for MC30	113
67784	Bolt M6x10 for MC30	14	67819	Start Capacitor for MC30	58	67840	Key 5x36 for MC30	114
67785	Bracket Plate for MC30	15	67820	Handle-Shifter for MC30	59	24994	Sleeve for MC30	115
67786	Stainless Steel Screw Nut M8 for MC30	16	67821	Plastic Block for MC30	60	67841	Main Shaft for MC30	116
67787	Spring for MC30	17	67822	Bolt M5x10 for MC30	61	25011	Bushing for MC30	117
65366	Stainless Steel Flat Washer Φ8 for MC30	18	67823	Bolt M4x6 for MC30	62	24995	Sleeve for MC30	118
67788	Side Guard Left/Right for MC30	19	25775	Drafty Plate for MC30	63	24996	Washer for MC30	119
67789	Swerve Sticker for MC30	20	67824	Bolt M4x14 for MC30	64	24997	Bearing 6206 for MC30	120
67790	Cover Plate Assembly for MC30	21	65378	Flat Washer Φ4 for MC30	65	24998	Bushing for MC30	121
67791	Bowl Locating Pin for MC30	22	64990	Handle Sleeve M12 for MC30	66	67842	Shifting Yoke for MC30	122
67792	Safety Grid for MC30	23	25778	Timer for MC30	67	24999	Oil Seal 40x62x8 for MC30	123
67793	Bowl for MC30	24	67825	Wire Whip for MC30	68	67843	Key 6x25 for MC30	124
67794	Electrical Baffle for MC30	25	67826	Bolt M8x40 for MC30	69	67844	Washer for MC30	125
67795	Press Board 1 for MC30	26	25068	Screw Nut M8 for MC30	70	24905	Bearing 6205 for MC30	126
67796	Safety Grid Positioning Block for MC30	27	67827	Back Cover for MC30	71	25004	Nut M18x1.5 for MC30	127
67797	Body Assembly for MC30	29	65374	Flat Washer Φ8 for MC30	72	67845	Working Shaft for MC30	128
25796	Handle Sleeve for MC30	30	25096	Spring Washer Φ8 for MC30	73	67846	Bolt M6x20 for MC30	129
67798	Safety Grid Positioning Block for MC30	31	67828	Bolt M8x20 for MC30	74	39316	Spring Washer Φ6 for MC30	130
67799	Speed Handle for MC30	32	67829	Guide Rail Plate for MC30	75	67847	Attachment Hub for MC30	131
67800	Connecting Rod for MC30	33	67830	Beater for MC30	76	67848	Fixed Sleeve for MC30	132
67801	Bolt M5x50 for MC30	34	67831	Bolt M5x8 for MC30	78	67849	Paper Washer for MC30	133
67802	Bolt ST4.8x12 for MC30	35	67832	Cotter 3x30 for MC30	79	24871	Check Ring for MC30	134
24922	Start Button for MC30	36	31569	Elastic Cylindrical Pin for MC30	80	67850	Gear for MC30	135
67803	Timer Knob for MC30	37	67833	Parameters Brand for MC30	81	25810	Cylindrical Gears Stuff Board for MC30	136
67804	Bolt M5x30 for MC30	38	65322	Bolt M8x20 for MC30	82	67851	Bolt M5x16 for MC30	137
67805	Stainless Steel Flat Washer Φ5 for MC30	39	67834	Connecting Rod for MC30	83	67852	Convex Head Cap for MC30	138
65357	Stainless Steel Flat Washer Φ5 for MC30	40	67835	Overload Switch for MC30	84	67853	Pad for MC30	139
67806	Bolt for MC30	41	24938	Flat Washer Φ14 for MC30	85	67854	Pad for MC30	140
25720	Elastic Cylindrical Pin 4x25 for MC30	42	25047	Flat Washer Φ12 for MC30	86	67855	Circlips 18 for MC30	141
67807	Bolt M3x6 for MC30	43	25046	Spring for MC30	87	24985	Plug Cover for MC30	142
67808	Top Cover for MC30	44	25029	Nut M12 for MC30	88	67856	Pin 6x20 for MC30	143

Parts Breakdown

Model MX-CN-0030 44388

Item No.	Description	Position	Item No.	Description	Position	Item No.	Description	Position
25007	Cover Gear Housing for MC30	144	67865	Spring Washer 5 for MC30	162	25024	Worm Gear for MC30	182
67857	Gearbox for MC30	145	67866	Circlips for MC30	163	25034	Circlips for Shaft 20 for MC30	183
24973	Shaft Circlips 19 for MC30	146	25088	Bearing 6203 for MC30	164	65371	Spring Washer 6 for MC30	184
24974	Planetary Gear for MC30	147	25022	Gear for MC30	165	25084	Bearing 6202 for MC30	185
67858	Key C6x50 for MC30	148	25013	Worm Wheel for MC30	166	25035	Circlips for Shaft 15 for MC30	186
24977	Oil Seal for MC30	149	24921	Oil Seal for MC30	167	25008	Flat Key 5x16 for MC30	187
67859	Shaft Holder for MC30	150	25719	Pin 4x30 for MC30	168	25009	Circlips for Shaft 17 for MC30	188
67860	Hexagon Screw M8x30 for MC30	151	25794	Steel Ball 6 for MC30	170	25765	Pin 6x30 for MC30	189
25018	Internal Gear for MC30	152	25718	Spring for MC30	171	67870	Motor for MC30	190
67861	Circlips 35 for MC30	153	67867	Handle Seat for MC30	172	67871	O-Ring Seal for MC30	191
65394	Phillips Screw M6x20 for MC30	154	67868	Handle Shaft for MC30	173	67872	O-Ring Seal for MC30	192
67862	Phillips Screw M5x10 for MC30	155	67869	Phillips Screw M5x12 for MC30	174	24980	Fork Shaft for MC30	193
67863	Cover for MC30	156	24959	Pin Shaft for MC30	175	67873	Fork for MC30	194
25023	Bushing for MC30	157	24958	Spring for MC30	176	24882	Spring Washer 10 for MC30	195
25021	Mid-Gear Wheel for MC30	158	24957	Adjusting Screw for MC30	177	25141	Nut M10 for MC30	196
25026	Gear for MC30	159	25029	Nut M12 for MC30	178	67874	Hexagon Screws M6x8 for MC30	197
25027	Gasket for MC30	160	25030	Spring Washer 12 for MC30	179			
67864	Bolt M5x14 for MC30	161	25032	Gear Wheel for MC30	181			

Parts Breakdown

Model MX-CN-0040 44389

General Assembly

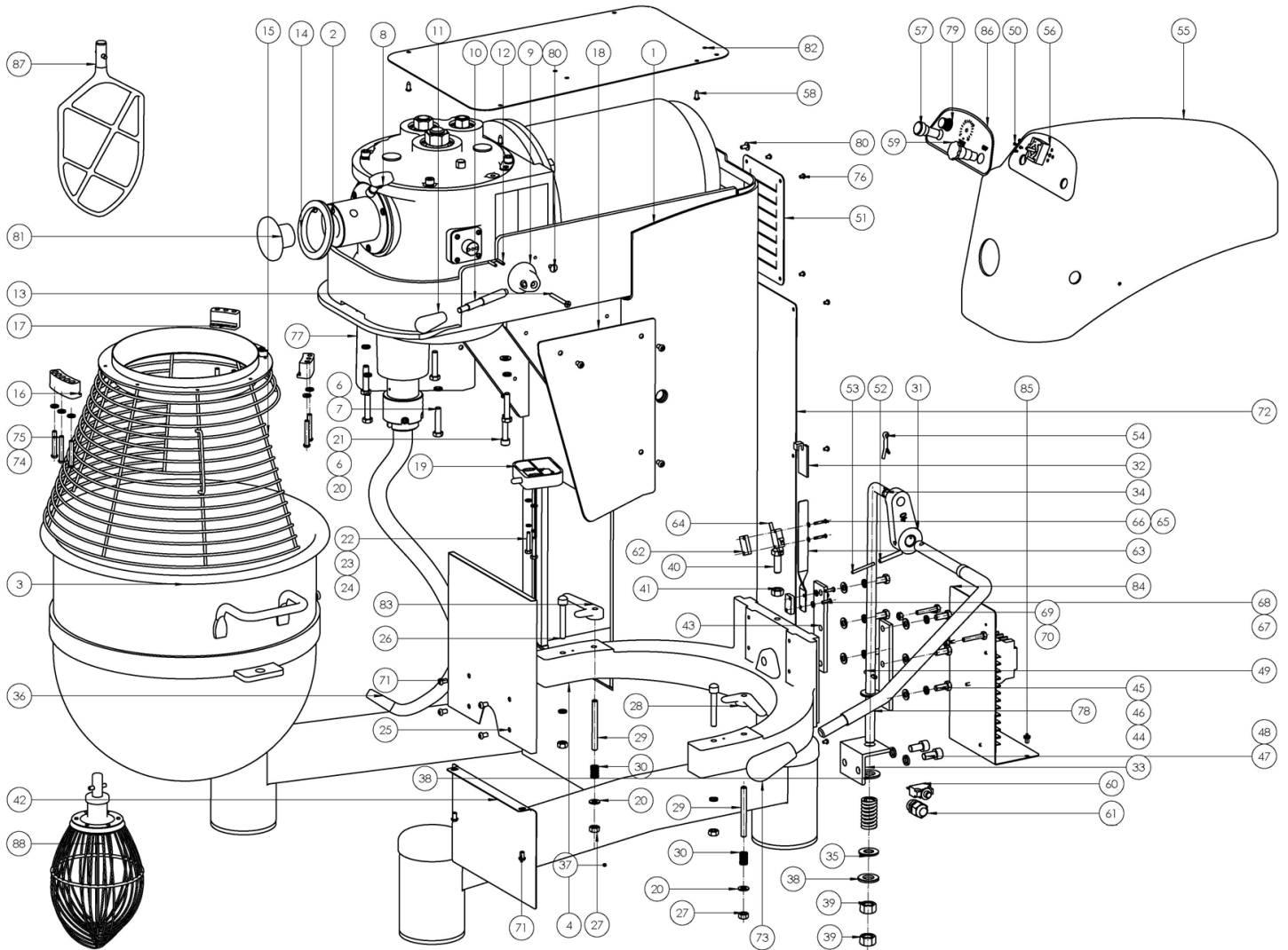

Parts Breakdown

Model MX-CN-0040 44389

Head

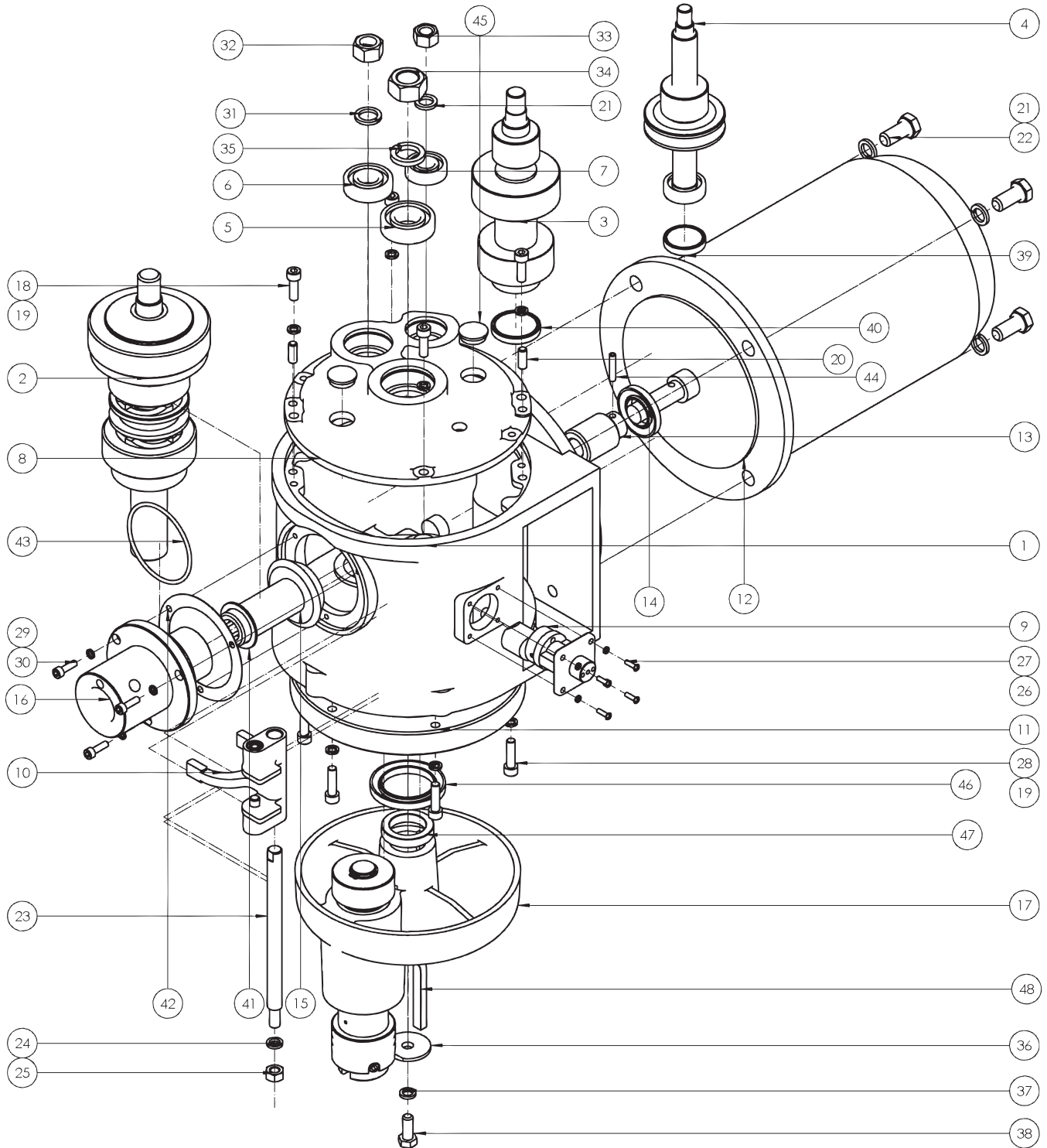

Parts Breakdown

Model MX-CN-0040 44389

General Assembly

Item No.	Description	Position	Item No.	Description	Position	Item No.	Description	Position
67885	Body for MC40	1	67894	Crank Lever for MC40	31	67775	Emergency Stop Button for MC40	59
67886	Bowl for MC40	3	67895	Crash Pad for MC40	32	67910	Thermal Relay for MC40	60
67887	Support for MC40	4	67896	Davit for MC40	33	67815	Water Joint M20x1.5 for MC40	61
67783	Stainless Steel Flat Washer $\Phi 8$ for MC40	6	67897	Connecting Rod for MC40	34	67821	Plastic Block for MC40	62
67888	Bolt M8x40 for MC40	7	24938	Flat Washer $\Phi 14$ for MC40	35	67816	Travel Cover for MC40	63
64977	Handle for MC40	8	67898	Hook for MC40	36	24947	Micro Switch for MC40	64
67800	Connecting Rod for MC40	9	67899	Spring for MC40	37	67810	Flat Washer $\Phi 3$ for MC40	65
67799	Speed Handle for MC40	10	25003	Flat Washer $\Phi 16$ for MC40	38	67911	Bolt M3x20 for MC40	66
25796	Handle Sleeve M8x58 for MC40	11	67900	Screw Nut M14 for MC40	39	65378	Flat Washer $\Phi 4$ for MC40	67
67777	Elastic Cylindrical Pin $\Phi 4 \times 20$ for MC40	12	65326	Bolt M10x30 for MC40	40	67912	Bolt M4x12 for MC40	68
67801	Bolt M5x50 for MC40	13	25141	Screw Nut M10 for MC40	41	67913	Bolt M6x35 for MC40	69
64985	Scraper Seal for MC40	14	67901	Cover Plate-Down for MC40	42	67914	Nut M6 for MC40	70
67889	Safety Grid for MC40	15	67902	Guide Rail Plate for MC40	43	67784	Screw M6x10 for MC40	71
67796	Safety Grid Positioning Block 1 for MC40	16	25096	Flat Washer $\Phi 5$ for MC40	44	67915	Back Cover for MC40	72
67798	Safety Grid Positioning Block 2 for MC40	17	67828	Bolt M8x20 for MC40	45	67916	Handle Sleeve M16x80 for MC40	73
67890	Side Guard Left / Right for MC40	18, 77	65374	Flat Washer $\Phi 8$ for MC40	46	65370	Stainless Steel Flat Washer $\Phi 6$ for MC40	74
67877	Stroke Hit Head for MC40	19	67903	Bolt M10x25 for MC40	47	67917	Screw M6x35 for MC40	75
65366	Stainless Steel Flat Washer $\Phi 8$ for MC40	20	24882	Spring Washer $\Phi 10$ for MC40	48	67823	Screw M4x6 for MC40	76
67804	Bolt M5x30 for MC40	22	67904	Elastic Cylindrical Pin $\Phi 5 \times 30$ for MC40	49	67918	Handle-Shifter for MC40	78
67805	Stainless Steel Flat Washer $\Phi 5$ for MC40	23	67807	Bolt M3x6 for MC40	50	67803	Black Knob for MC40	79
65357	Flat Washer $\Phi 5$ for MC40	24	67905	Drafty Plate for MC40	51	67822	Screw M5x10 for MC40	80
67891	Cover Plate Assembly for MC40	25	67906	Elastic Cylindrical Pin $\Phi 6 \times 40$ for MC40	52	67778	Plug for MC40	81
67892	Bowl Locating Pin for MC40	26	67907	Elastic Cylindrical Pin $\Phi 4 \times 40$ for MC40	53	67919	Electrical Baffle for MC40	82
67786	Screw Nut M8 for MC40	27	67908	Cotter 3x25 for MC40	54	67920	Screw M5x8 for MC40	85
67795	Press Board 1/2 for MC40	28, 83	67909	Top Cover for MC40	55	67921	Sticker for MC40	86
67893	Clamp Screw for MC40	29	65253	Timer for MC40	56	67922	Beater for MC40	87
67787	Stainless Steel Spring for MC40	30	24922	Start Button for MC40	57	67923	Wire Whip for MC40	88

Parts Breakdown

Model **MX-CN-0040** 44389

Head

Item No.	Description	Position	Item No.	Description	Position	Item No.	Description	Position
67924	Gearbox for MC40	1	24905	Bearing 6205-Z for MC40	5	24997	Bearing 6206-Z for MC40	17
67925	Key A=10mm x 45mm for MC40	2	25070	Bearing 6204-Z for MC40	6	24905	Bearing 6205-Z for MC40	17
67926	Spacer-Lower-2 for MC40	2	25088	Bearing 6203-Z for MC40	7	67966	Shaft Holder for MC40	17
67927	Bearing 6207-Z for MC40	2	67950	Cover, Gear Housing for MC40	8	67967	Screw M8x25 for MC40	18
67928	Spacer-Lower-1 for MC40	2	67872	O-Ring 9x1.8 for MC40	9	25096	Spring Washer Φ8 for MC40	19
67929	Clutch Gear for MC40	2	67871	O-Ring 33.5x1.8 for MC40	9	67968	PinΦ8x20 for MC40	20
67930	Sleeve Clutch for MC40	2	25719	Elastic Cylindrical Pin Φ4x30 for MC40	9	24893	Spring Washer Φ14 for MC40	21
67931	Key A=10mm x 35mm for MC40	2	25794	Steel Ball Φ6 for MC40	9	67969	Bolt M14x30 for MC40	22
67932	Bushing for MC40	2	25718	Spring for MC40	9	67970	Shift Rail for MC40	23
67933	Clutch Gear for MC40	2	67951	Handle-Shifter for MC40	9	67971	Spring Washer Φ16 for MC40	24
67934	Gear for MC40	2	67952	Cam-Gear Shifter for MC40	9	67972	Spring Washer Φ4 for MC40	26
67935	Super Machine Parts for MC40	2	67867	Plate-Shifter Index for MC40	9	67824	Screw M4x14 for MC40	27
67936	Gear for MC40	2	24957	Adjusting Screw for MC40	10	67860	Screw M8x30 for MC40	28
67937	Roller 12x27 for MC40	2	67953	Pin Shaft for MC40	10	39316	Spring Washer Φ6 for MC40	29
67938	Main Shaft for MC40	2	67954	Spring for MC40	10	67846	Screw M6x20 for MC40	30
67939	Key C=8mm x 28mm for MC40	3	67955	Shifting Yoke for MC40	10	25004	Nut M18x1.5 for MC40	32
67940	Key A=8mm x 28mm for MC40	3	67956	Internal Gear for MC40	11	25714	Nut M14x1.5 for MC40	33
25070	Bearing 6204-Z for MC40	3	67957	Motor for MC40	12	67973	Nut M22x1.5 for MC40	34
25034	Shaft Circlips 20 for MC40	3	67958	Worm Wheel for MC40	13	67974	Spring Washer Φ22 for MC40	35
67941	Bushing for MC40	3	24977	Oil seal 28x52x7 for MC40	14	67975	Running Clamp for MC40	36
67942	Bushing for MC40	3	67959	Gear for MC40	15	67976	Bolt M10x25 for MC40	38
67943	Gear for MC40	3	67960	Attachment Hub for MC40	16	25028	Plug Cover for MC40	39
67944	Gear for MC40	3	39316	Spring Washer Φ6 for MC40	17	67977	Plug Cover for MC40	40
67945	Mid-Gear Wheel for MC40	3	67874	Screw M6x8 for MC40	17	24871	Ring for MC40	41
25088	Bearing 6203-Z for MC40	4	67961	Fixed Sleeve for MC40	17	67978	O-Ring for MC40	43
25009	Shaft Circlips 17 for MC40	4	67946	Shaft Circlips 24 for MC40	17	25765	Pin Φ6x30 for MC40	44
67946	Shaft Circlips 24 for MC40	4	67962	Planetary Gear for MC40	17	24985	Plug Cover for MC40	45
67947	Key A=6mm x 22mm for MC40	4	67963	Key A=6mm x 30mm for MC40	17	67979	Oil Seal 50x72x8 for MC40	46
67948	Worm Gear for MC40	4	67964	Oil Seal 35x62x7 for MC40	17	67980	Spacer-Lower-3 for MC40	47
67949	Worm-Wheel Shaft for MC40	4	67965	Run Bearing for MC40	17	67981	Key C=10mm x 75mm for MC40	48

Parts Breakdown

Model MX-CN-0060 44390

General Assembly

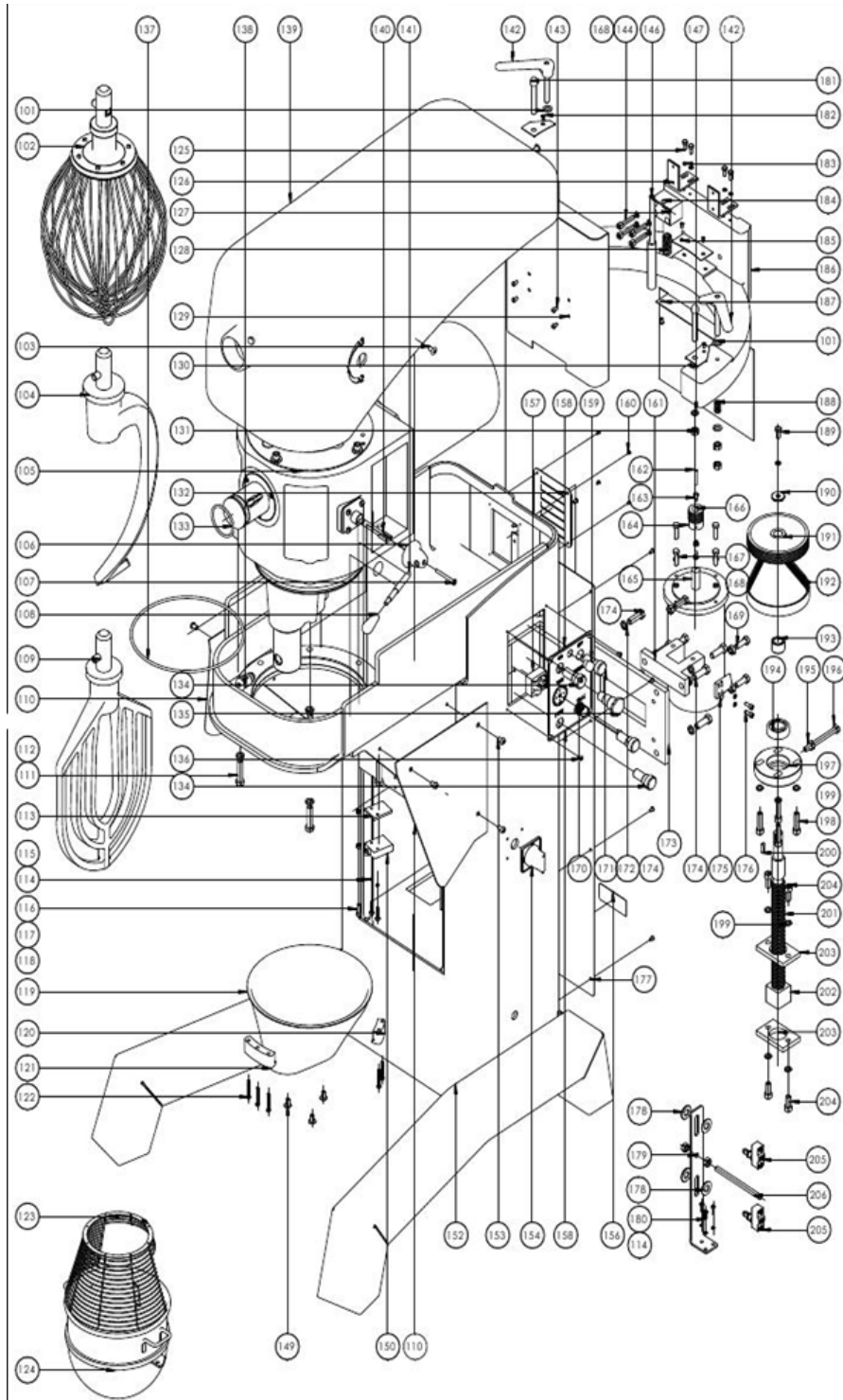

Parts Breakdown

Model MX-CN-0060 44390

Head

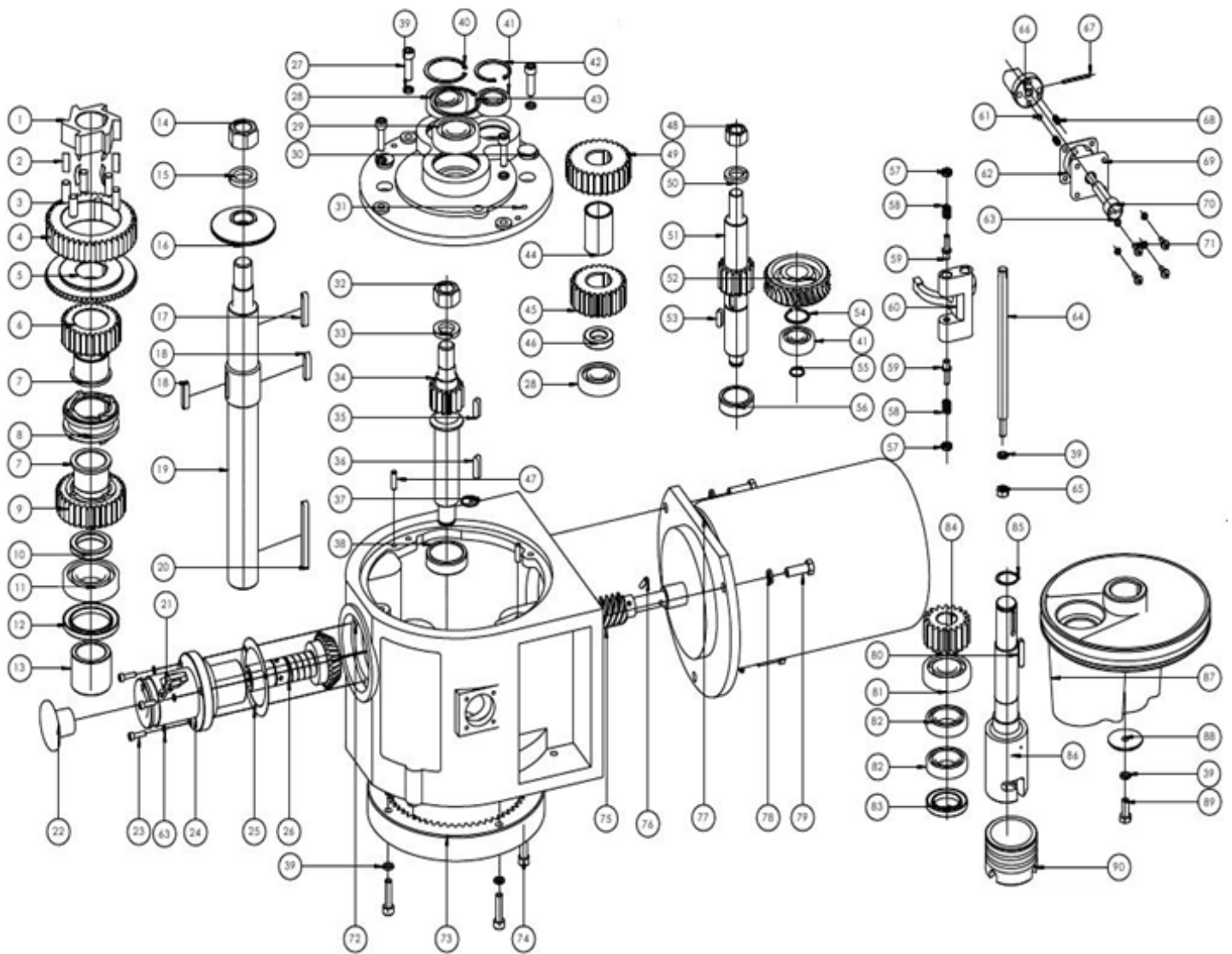

Parts Breakdown

Model MX-CN-0060 44390

General Assembly

Item No.	Description	Position	Item No.	Description	Position	Item No.	Description	Position
67982	Flat Washer 10 for MC60	101	68002	O-Ring 250x5.3G for MC60	137	68019	Hexagon Screw M6x16 for MC60	176
67983	Wire Whipper for MC60	102	68003	Top Cover for MC60	139	68025	Back Cover Plate for MC60	177
67984	Slotted Screws M8x15 for MC60	103	68004	Pin 5x25 for MC60	140	24938	Flat Washer 14 for MC60	178
67985	Spiral Hook for MC60	104	68005	Gear Shift Lever for MC60	141	68026	Tour Guide for MC60	179
67986	Shaft for MC60	106	68006	Press Board for MC60	142	67851	Phillips Screw M5x16 for MC60	180
67987	Phillips Screw M6x60 for MC60	107	67784	Hexagon Screws M6x10 for MC60	143	68027	Clamp Screw for MC60	181
25796	Rubber Grip for MC60	108	68007	Hexagon Screw M8x40 for MC60	144	68028	Phillips Screw M4x10 for MC60	182
67988	Flat Beater for MC60	109	68008	Shaft for MC60	146	39316	Spring Washer 6 for MC60	183
67989	Side Guard for MC60	110	68009	Spring Washer 10 for MC60	147	68029	Bowl Roller Seat for MC60	184
65319	Bolt M12x50 for MC60	111	67984	Slotted Screws M8x15 for MC60	149	68030	Bracket Block 2 for MC60	185
65321	Spring Washer 12 for MC60	112	68010	D4C Switch for MC60	150	68031	Support for MC60	186
67990	Subplate for MC60	113	68011	Body Assembly for MC60	152	68032	Bottom Cover for MC60	187
67865	Spring Washer 5 for MC60	114	68012	Hexagon Screws M8x12 for MC60	153	68033	Spring for MC60	188
67991	Hexagon Screw M5x25 for MC60	115	68013	Stop Switch-1 for MC60	154	67828	Bolt M8x20 for MC60	189
67846	Hexagon Screw M6x20 for MC60	116	68014	Stop Switch-1 for MC60	154	68034	Wheel Plate for MC60	190
39316	Spring Washer 6 for MC60	117	67833	Parameter Plate for MC60	156	68035	Wheel for MC60	191
67914	Nut M6 for MC60	118	25778	Timer for MC60	157	68036	Belt 10PJ 570 for MC60	192
67992	Gasket for MC60	119	68015	Sticker for MC60	158	68037	Shaft Sleeve for MC60	193
67796	Located Bloc for MC60	120	68016	Sticker for MC60	158	68038	Bearing 6304 for MC60	194
67798	Located Bloc for MC60	121	67823	Hexagon Screws M4x6 for MC60	160	25141	Nut M10 for MC60	195
67993	Hexagon Screws M6x40 for MC60	122	68017	Handle-Shifter Seat for MC60	161	68039	Bolt M10x100 for MC60	196
67994	Safety Guard for MC60	123	68018	Key C6x35 for MC60	162	68040	Shaft Block for MC60	197
67995	Bowl for MC60	124	68019	Hexagon Screw M6x15 for MC60	163	68041	Hexagon Screw M10x40 for MC60	198
67996	Bolt M6x16 for MC60	125	68020	Small Pulley for MC60	164	24882	Spring Washer 10 for MC60	199
67997	Angle Iron for MC60	126	68021	Lifting Motor for MC60	165	67947	Flat Key 6x22 for MC60	200
25720	Pin 4x25 for MC60	127	67779	Nut M6 for MC60	166	68042	Screw Rod for MC60	201
25046	Spring for MC60	128	25096	Spring Washer 8 for MC60	168	68043	Feed Screw Nut for MC60	202
67998	Top Cover Assembly for MC60	129	68022	Bolt M8x30 for MC60	167	68044	Nut Clamp for MC60	203
67999	Bracket Block 1 for MC60	130	65326	Bolt M10x30 for MC60	169	68045	Hexagon Screw M10x25 for MC60	204
25141	Nut M10 for MC60	131	67803	Speed Control for MC60	170	68046	Limit Switch for MC60	205
68000	Ventilation Plate for MC60	132	24924	Stop Button for MC60	171	68047	Strut for MC60	206
68001	O-Ring 55x5G for MC60	133	25030	Spring Washer 12 for MC60	172	68048	Electrical Baffle for MC60	207
24922	Start Button for MC60	134	68023	Lifting Clamp for MC60	173	68049	Heavy Duty Connector for MC60	208
67775	Emergency Stop Button for MC60	135	65303	Bolt M12x35 for MC60	174	67802	Screw ST4.8x12 for MC60	209
24924	Stop Button for MC60	136	68024	Block for MC60	175			

Parts Breakdown

Model **MX-CN-0060** 44390

Head

Item No.	Description	Position	Item No.	Description	Position	Item No.	Description	Position
68050	Gear for MC60	1	68071	Cover, Gear Housing for MC60	31	68093	Steel Ball 8 for MC60	61
68051	Coil Spring for MC60	2	68072	Nut M24x2 for MC60	32	68094	Gasket for MC60	62
68052	Roller for MC60	3	68073	Spring Washer 24 for MC60	33	39316	Spring Washer 6 for MC60	63
68053	Super Machine Parts for MC60	4	68074	Mid-Gear Wheel for MC60	34	68095	Declutch Shift Shaft for MC60	64
68054	Level Drive Gear for MC60	5	67940	Flat Key 8x28 for MC60	35	25141	Nut M10 for MC60	65
68055	Clutch Gear for MC60	6	68075	Flat Key 8x32 for MC60	36	68096	Cam-Gear Shifter for MC60	66
68056	Bushing for MC60	7	68076	Circlips for Shaft 25 for MC60	37	68097	Elastic Cylindrical Pin 4x45 for MC60	67
68057	Sleeve Clutch for MC60	8	68077	Plug 1 for MC60	38	68098	Spring for MC60	68
68058	Clutch Gear for MC60	9	24882	Spring Washer 10 for MC60	39	68099	Plate-Shifter Index for MC60	69
68059	Shaft Bushing for MC60	10	68078	Circlips 62 for MC60	40	68100	Handle-Shifter for MC60	70
28665	Bearing 6209 for MC60	11	68038	Bearing 6304 for MC60	41	65394	Phillips Screw M6x20 for MC60	71
68060	Oil Seal for MC60	12	68079	Circlips 52 for MC60	42	68101	Gear Box for MC60	72
68061	Bushing for MC60	13	68080	Circlips 72 for MC60	43	68102	Internal Gear for MC60	73
68062	Nut M27x2 for MC60	14	68081	Bushing for MC60	44	68041	Hexagon Screw M10x40 for MC60	74
68063	Spring Washer 27 for MC60	15	68082	Gear for MC60	45	68103	Worm Wheel for MC60	75
68059	Shaft Bushing for MC60	16	68083	Gasket for MC60	46	25765	Elastic Cylindrical Pin 6x30 for MC60	76
65338	Flat Key 10x50 for MC60	17	68084	Pin 8x26 for MC60	47	68104	Motor for MC60	77
68064	Flat Key 10x40 for MC60	18	65348	Nut M20x1.5 for MC60	48	25030	Spring Washer 12 for MC60	78
68065	Main Shaft for MC60	19	68085	Gear for MC60	49	65303	Bolt M12x35 for MC60	79
68066	Key C10x60 for MC60	20	68086	Spring Washer 20 for MC60	50	68105	Flat Key 8x40 for MC60	80
64977	Thumb Screw for MC60	21	68087	Gear Wheel for MC60	51	68070	Bearing 6306 for MC60	81
24967	Attachment Hole Plug for MC60	22	68088	Worm Gear for MC60	52	68106	Bearing 6007 for MC60	82
67846	Hexagon Screw M6x20 for MC60	23	68089	Flat Key 8x25 for MC60	53	24999	Oil Seal for MC60	83
68067	Attachment Hub for MC60	24	68090	Circlips for Shaft 34 for MC60	54	68107	Planetary Gear for MC60	84
67849	Gasket for MC60	25	25034	Circlips for Shaft 20 for MC60	55	68108	Circlips for Shaft 30 for MC60	85
68068	Bevel Gear Unit for MC60	26	68091	Plug 2 for MC60	56	68109	Working Shaft for MC60	86
68045	Hexagon Screw M10x35 for MC60	27	24957	Plunger-Shifter Yoke for MC60	57	68110	Operating Shaft for MC60	87
68069	Bearing 6305 for MC60	28	67954	Spring for MC60	58	68111	Running Clamp for MC60	88
68070	Bearing 6306 for MC60	29	67953	Pin Shaft for MC60	59	68112	Bolt M10x25 for MC60	89
24985	Plug Cover for MC60	30	68092	Shifting Yoke for MC60	60	68113	Agitator Joint Shaft for MC60	90

Parts Breakdown

Model MX-CN-0080 44391

General Assembly

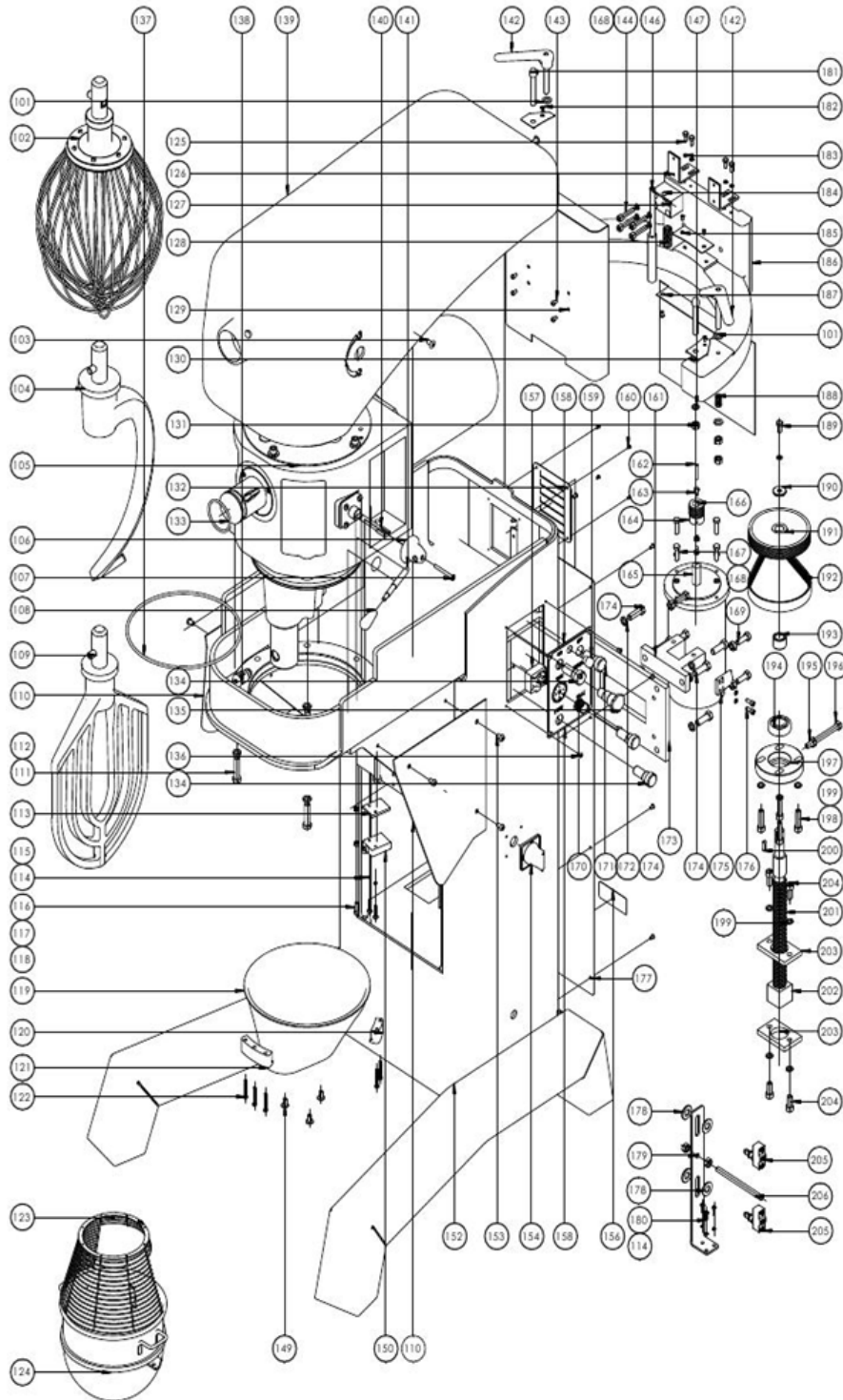

Parts Breakdown

Model MX-CN-0080 44391

Head

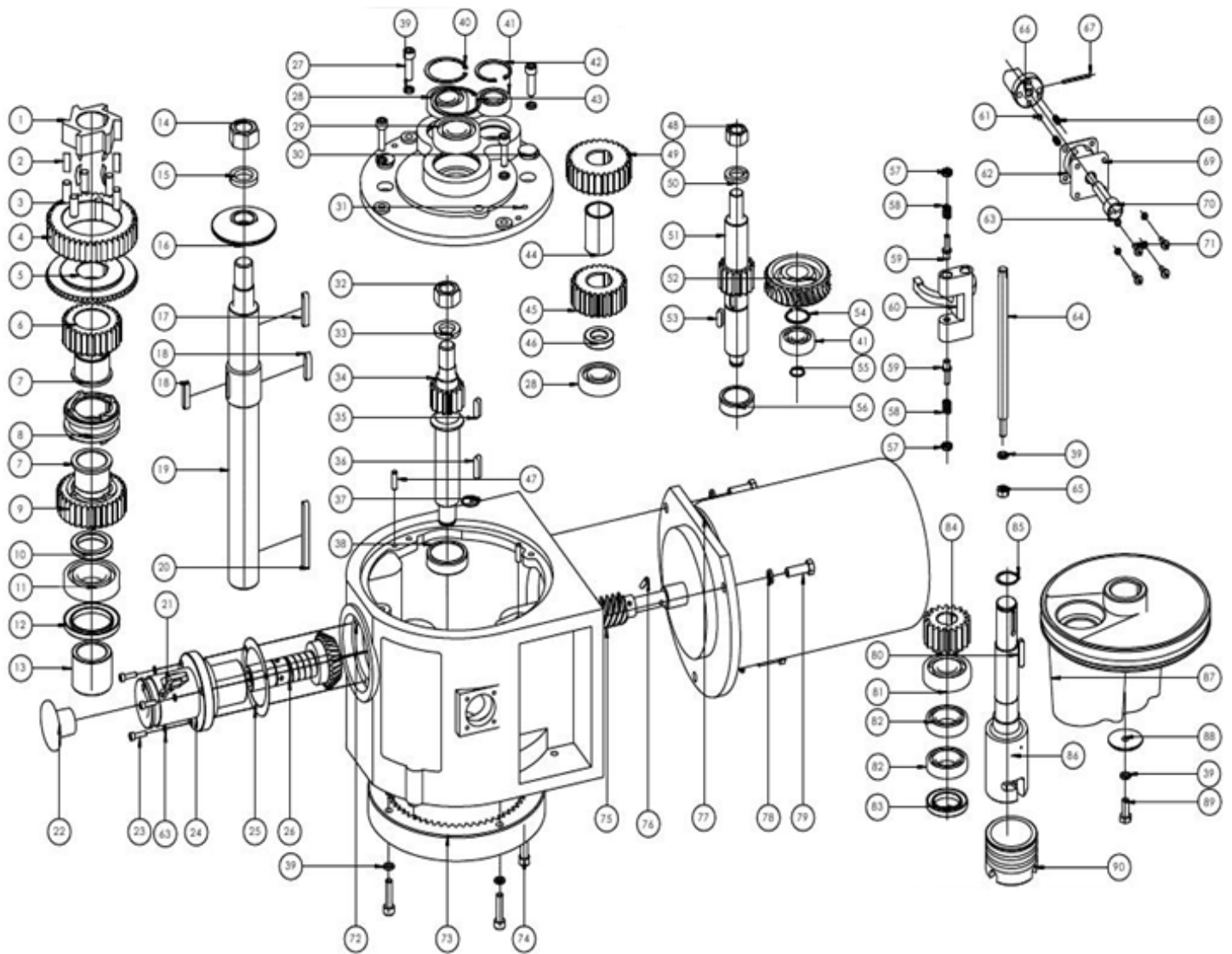

Parts Breakdown

Model MX-CN-0080 44391

General Assembly

Item No.	Description	Position	Item No.	Description	Position	Item No.	Description	Position
67982	Flat Washer 10 for MC80	101	68002	O-Ring 250x5.3G for MC80	137	68024	Block for MC80	175
68114	Wire Whipper for MC80	102	68003	Top Cover for MC80	139	68019	Hexagon Screw M6x16 for MC80	176
67984	Slotted Screws M8x15 for MC80	103	68004	Pin 5x25 for MC80	140	68025	Back Cover Plate for MC80	177
68115	Spiral Hook for MC80	104	68005	Gear Shift Lever for MC80	141	24938	Flat Washer 14 for MC80	178
67986	Shaft for MC80	106	68006	Press Board for MC80	142	68026	Tour Guide for MC80	179
67987	Phillips Screw M6x60 for MC80	107	67784	Hexagon Screws M6x10 for MC80	143	67851	Phillips Screw M5x16 for MC80	180
25796	Rubber Grip for MC80	108	68007	Hexagon Screw M8x40 for MC80	144	68027	Clamp Screw for MC80	181
68116	Flat Beater for MC80	109	68008	Shaft for MC80	146	68028	Phillips Screw M4x10 for MC80	182
67989	Side Guard for MC80	110	68009	Spring Washer 10 for MC80	147	39316	Spring Washer 6 for MC80	183
65319	Bolt M12x50 for MC80	111	68118	Slotted Screws M8x15 for MC80	149	68029	Bowl Roller Seat for MC80	184
65321	Spring Washer 12 for MC80	112	68010	D4C Switch for MC80	150	68030	Bracket Block 2 for MC80	185
67990	Subplate for MC80	113	67989	Body Assembly for MC80	151	68031	Support for MC80	186
67865	Spring Washer 5 for MC80	114	68011	Hexagon Screws M8x12 for MC80	152	68032	Bottom Cover for MC80	187
67991	Hexagon Screw M5x25 for MC80	115	68012	Hexagon Screws M8x12 for MC80	153	68033	Spring for MC80	188
67846	Hexagon Screw M6x20 for MC80	116	68013	Stop Switch-1 for MC80	154	67828	Bolt M8x20 for MC80	189
39316	Spring Washer 6 for MC80	117	68014	Stop Switch-1 for MC80	154	68034	Wheel Plate for MC80	190
67914	Nut M6 for MC80	118	67833	Parameter Plate for MC80	156	68035	Wheel for MC80	191
67992	Gasket for MC80	119	25778	Timer for MC80	157	68036	Belt 10PJ 570 for MC80	192
67796	Located Bloc for MC80	120	68015	Sticker for MC80	158	68037	Shaft Sleeve for MC80	193
67798	Located Bloc for MC80	121	68016	Sticker for MC80	158	68038	Bearing 6304 for MC80	194
67993	Hexagon Screws M6x40 for MC80	122	67823	Hexagon Screws M4x6 for MC80	160	25141	Nut M10 for MC80	195
67994	Safety Guard for MC80	123	68017	Handle-Shifter Seat for MC80	161	68039	Bolt M10x100 for MC80	196
68117	Bowl for MC80	124	68018	Key C6x35 for MC80	162	68040	Shaft Block for MC80	197
67996	Bolt M6x16 for MC80	125	68019	Hexagon Screw M6x15 for MC80	163	68041	Hexagon Screw M10x40 for MC80	198
67997	Angle Iron for MC80	126	68020	Small Pulley for MC80	164	24882	Spring Washer 10 for MC80	199
25720	Pin 4x25 for MC80	127	68021	Lifting Motor for MC80	165	67947	Flat Key 6x22 for MC80	200
25046	Spring for MC80	128	67779	Nut M6 for MC80	166	68042	Screw Rod for MC80	201
67998	Top Cover Assembly for MC80	129	25096	Spring Washer 8 for MC80	168	68043	Feed Screw Nut for MC80	202
67999	Bracket Block 1 for MC80	130	68022	Bolt M8x30 for MC80	167	68044	Nut Clamp for MC80	203
25141	Nut M10 for MC80	131	65326	Bolt M10x30 for MC80	169	68045	Hexagon Screw M10x25 for MC80	204
68000	Ventilation Plate for MC80	132	67803	Speed Control for MC80	170	68046	Limit Switch for MC80	205
68001	O-Ring 55x5G for MC80	133	24924	Stop Button for MC80	171	68047	Strut for MC80	206
24922	Start Button for MC80	134	25030	Spring Washer 12 for MC80	172	68048	Electrical Baffle for MC80	207
67775	Emergency Stop Button for MC80	135	68023	Lifting Clamp for MC80	173	68049	Heavy Duty Connector for MC80	208
24924	Stop Button for MC80	136	65303	Bolt M12x35 for MC80	174	67802	Screw ST4.8x12 for MC80	209

Parts Breakdown

Model MX-CN-0080 44391

Head

Item No.	Description	Position	Item No.	Description	Position	Item No.	Description	Position
68050	Gear for MC80	1	68071	Cover, Gear Housing for MC80	31	68093	Steel Ball 8 for MC80	61
68051	Coil Spring for MC80	2	68072	Nut M24x2 for MC80	32	68094	Gasket for MC80	62
68052	Roller for MC80	3	68073	Spring Washer 24 for MC80	33	39316	Spring Washer 6 for MC80	63
68053	Super Machine Parts for MC80	4	68074	Mid-Gear Wheel for MC80	34	68095	Declutch Shift Shaft for MC80	64
68054	Level Drive Gear for MC80	5	67940	Flat Key 8x28 for MC80	35	25141	Nut M10 for MC80	65
68055	Clutch Gear for MC80	6	68075	Flat Key 8x32 for MC80	36	68096	Cam-Gear Shifter for MC80	66
68056	Bushing for MC80	7	68076	Circlips for Shaft 25 for MC80	37	68097	Elastic Cylindrical Pin 4x45 for MC80	67
68057	Sleeve Clutch for MC80	8	68077	Plug 1 for MC80	38	68098	Spring for MC80	68
68058	Clutch Gear for MC80	9	24882	Spring Washer 10 for MC80	39	68099	Plate-Shifter Index for MC80	69
68059	Shaft Bushing for MC80	10	68078	Circlips 62 for MC80	40	68100	Handle-Shifter for MC80	70
28665	Bearing 6209 for MC80	11	68038	Bearing 6304 for MC80	41	65394	Phillips Screw M6x20 for MC80	71
68060	Oil Seal for MC80	12	68079	Circlips 52 for MC80	42	68101	Gear Box for MC80	72
68061	Bushing for MC80	13	68080	Circlips 72 for MC80	43	68102	Internal Gear for MC80	73
68062	Nut M27x2 for MC80	14	68081	Bushing for MC80	44	68041	Hexagon Screw M10x40 for MC80	74
68063	Spring Washer 27 for MC80	15	68082	Gear for MC80	45	68103	Worm Wheel for MC80	75
68059	Shaft Bushing for MC80	16	68083	Gasket for MC80	46	25765	Elastic Cylindrical Pin 6x30 for MC80	76
65338	Flat Key 10x50 for MC80	17	68084	Pin 8x26 for MC80	47	68104	Motor for MC80	77
68064	Flat Key 10x40 for MC80	18	65348	Nut M20x1.5 for MC80	48	25030	Spring Washer 12 for MC80	78
68065	Main Shaft for MC80	19	68085	Gear for MC80	49	65303	Bolt M12x35 for MC80	79
68066	Key C10x60 for MC80	20	68086	Spring Washer 20 for MC80	50	68105	Flat Key 8x40 for MC80	80
64977	Thumb Screw for MC80	21	68087	Gear Wheel for MC80	51	68070	Bearing 6306 for MC80	81
24967	Attachment Hole Plug for MC80	22	68088	Worm Gear for MC80	52	68106	Bearing 6007 for MC80	82
67846	Hexagon Screw M6x20 for MC80	23	68089	Flat Key 8x25 for MC80	53	24999	Oil Seal for MC80	83
68067	Attachment Hub for MC80	24	68090	Circlips for Shaft 34 for MC80	54	68107	Planetary Gear for MC80	84
67849	Gasket for MC80	25	25034	Circlips for Shaft 20 for MC80	55	68108	Circlips for Shaft 30 for MC80	85
68068	Bevel Gear Unit for MC80	26	68091	Plug 2 for MC80	56	68109	Working Shaft for MC80	86
68045	Hexagon Screw M10x35 for MC80	27	24957	Plunger-Shifter Yoke for MC80	57	68110	Operating Shaft for MC80	87
68069	Bearing 6305 for MC80	28	67954	Spring for MC80	58	68111	Running Clamp for MC80	88
68070	Bearing 6306 for MC80	29	67953	Pin Shaft for MC80	59	68112	Bolt M10x25 for MC80	89
24985	Plug Cover for MC80	30	68092	Shifting Yoke for MC80	60	68113	Agitator Joint Shaft for MC80	90

Electrical Schematics

Model MX-CN-0020 43560

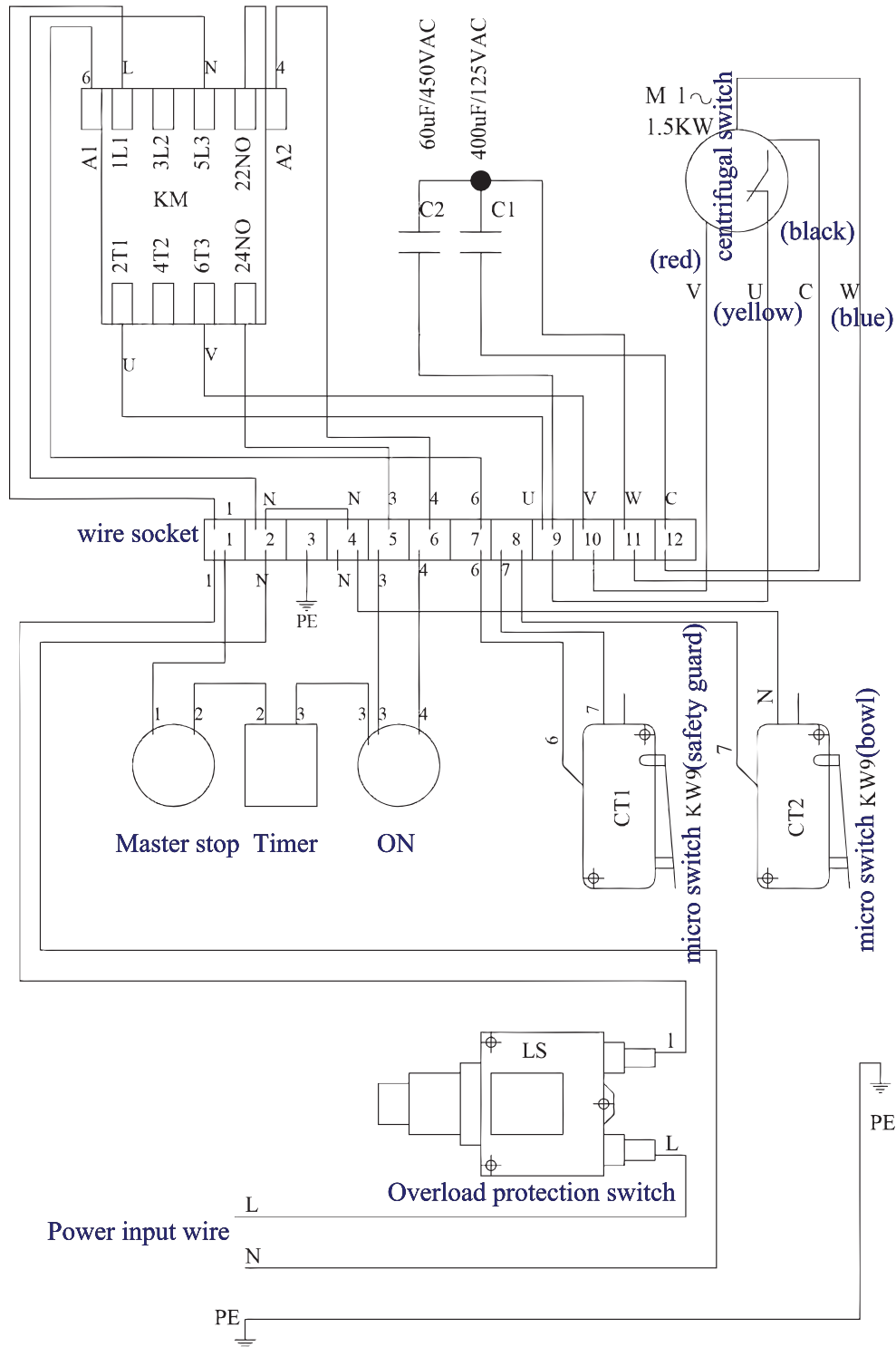

Electrical Schematics

Model MX-CN-0030 44388

Model MX-CN-0040 44389

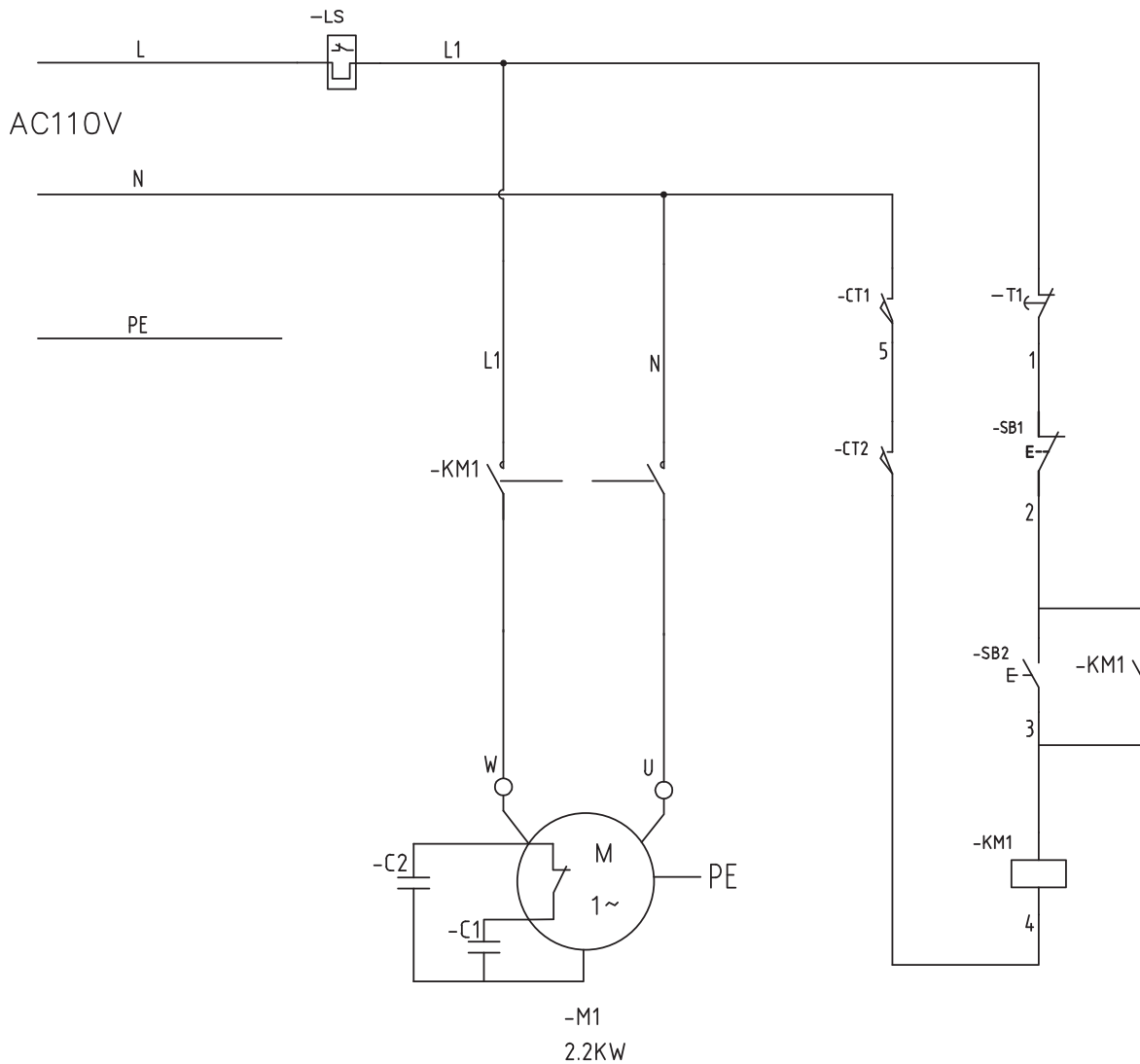

CODE	DESCRIPTION	CODE	DESCRIPTION
C1	START CAPACITOR	LS	OVERFLOW PROTECT SWITCH
C2	WORKING CAPACITOR	M1	MAIN MOTOR
CT1	MICROSWITCH	SB1	STOP BUTTON
CT2	MICROSWITCH	SB2	START BUTTON
KM1	AC CONTACTOR	T1	TIMER

Electrical Schematics

Model MX-CN-0060 44390

Model MX-CN-0080 44391

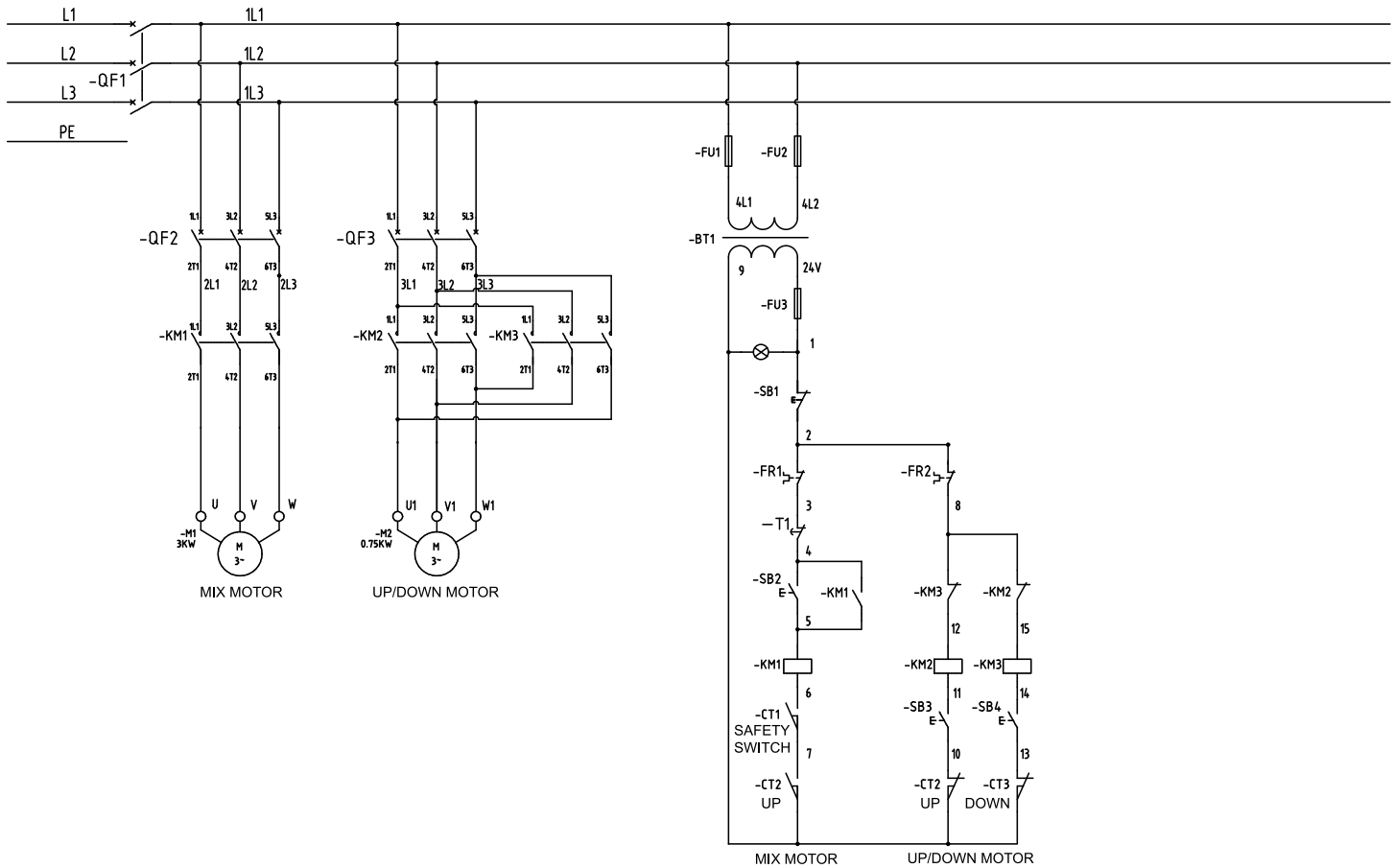

CODE	DESCRIPTION	CODE	DESCRIPTION
BT1	Transformer	QF1	Breaker
CT1	Microswitch	QF2	Breaker
CT2-3	Microswitch	QF3	Breaker
FU1-2	Fuse	SB1	Stop Button
FU3	Fuse	SB2-4	Start Button
KM1	Contactors	T1	Timer
KM2-3	Contactors		



Warranty Registration

Thank you for purchasing an Omcan product. To register your warranty for this product, complete the information below, tear off the card at the perforation and then send to the address specified below. You can also register online by visiting:

Merci d'avoir acheté un produit Omcan. Pour enregistrer votre garantie pour ce produit, complétez les informations ci-dessous, détachez la carte au niveau de la perforation, puis l'envoyer à l'adresse spécifiée ci-dessous. Vous pouvez également vous inscrire en ligne en visitant:

Gracias por comprar un producto Omcan usted. Para registrar su garantía para este producto, complete la información a continuación, cortar la tarjeta en la perforación y luego enviarlo a la dirección indicada a continuación. También puede registrarse en línea en:

<https://omcan.com/warranty-registration/>

For mailing in Canada

Pour postale au Canada

Por correo en Canadá

OMCAN

PRODUCT WARRANTY REGISTRATION

3115 Pepper Mill Court,

Mississauga, Ontario

Canada, L5L 4X5

For mailing in the US

Pour diffusion aux États-Unis

Por correo en los EE.UU.

OMCAN

PRODUCT WARRANTY REGISTRATION

4450 Witmer Industrial Estates, Unit 4,

Niagara Falls, New York

USA, 14305

or email to: service@omcan.com



Purchaser's Information

Name: _____

Address: _____

City: _____ Province or State: _____ Postal or Zip: _____

Country: _____

Dealer from which Purchased: _____

Dealer City: _____ Dealer Province or State: _____

Invoice: _____

Model Name: _____ Model Number: _____

Machine Description: _____

Date of Purchase (MM/DD/YYYY): _____

Would you like to extend the warranty? Yes No

Company Name: _____

Telephone: _____

Email Address: _____

Type of Company:

Restaurant Bakery Deli

Butcher Supermarket Caterer

Institution (specify): _____

Other (specify): _____

Serial Number: _____

Date of Installation (MM/DD/YYYY): _____

Thank you for choosing Omcan | Merci d'avoir choisi Omcan | Gracias por elegir Omcan



Since 1951 Omcan has grown to become a leading distributor of equipment and supplies to the North American food service industry. Our success over these many years can be attributed to our commitment to strengthen and develop new and existing relationships with our valued customers and manufacturers. Today with partners in North America, Europe, Asia and South America, we continually work to improve and grow the company. We strive to offer customers exceptional value through our qualified local sales and service representatives who provide convenient access to over 5,000 globally sourced products.

Depuis 1951 Omcan a grandi pour devenir un des “leaders” de la distribution des équipements et matériel pour l’industrie des services alimentaires en Amérique du Nord. Notre succès au cours de ces nombreuses années peut être attribué à notre engagement à renforcer et à développer de nouvelles et existantes relations avec nos clients et les fabricants de valeur. Aujourd’hui avec des partenaires en Amérique du Nord, Europe, Asie et Amérique du Sud, nous travaillons continuellement à améliorer et développer l’entreprise. Nous nous efforçons d’offrir à nos clients une valeur exceptionnelle grâce à nos ventes locales qualifiées et des représentants de service qui offrent un accès facile à plus de 5000 produits provenant du monde entier.

Desde 1951 Omcan ha crecido hasta convertirse en un líder en la distribución de equipos y suministros de alimentos en América del Norte industria de servicios. Nuestro éxito en estos años se puede atribuir a nuestro compromiso de fortalecer y desarrollar nuevas relaciones existentes con nuestros valiosos clientes y fabricantes. Hoy con socios de América del Norte, Europa, Asia y América del Sur, que trabajan continuamente para mejorar y crecer la empresa. Nos esforzamos por ofrecer a nuestros clientes valor excepcional a través de nuestro local de ventas y representantes de los servicios que proporcionan un fácil acceso a más de 5,000 productos con origen a nivel mundial.

