

Parts Breakdown

Model MX-CN-0043 19195

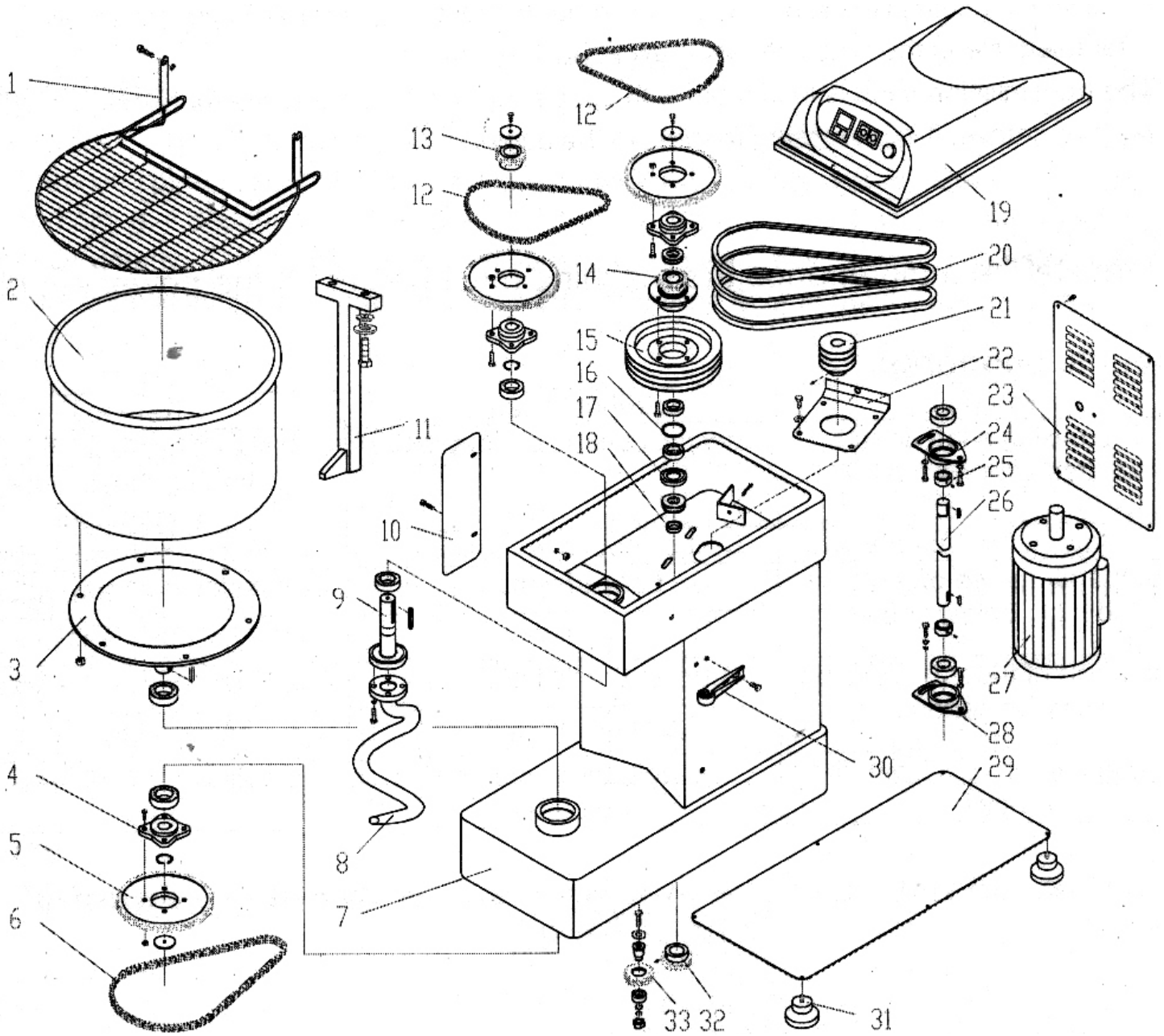

Parts Breakdown

Model MX-CN-0043 19195

Item No.	Description	Position	Item No.	Description	Position	Item No.	Description	Position
76963	Protective Casing for 19195	1	76975	Chain Pulley Z = 19 for 19195	13	76987	Locking Ring for 19195	25
76964	Bowl for 19195	2	76976	Chain Pulley Seat for 19195	14	76988	Transmission Shaft for 19195	26
76965	Bowl Support for 19195	3	76977	Big Belt Pulley for 19195	15	76989	Motor for 19195	27
76966	Chain Seat for 19195	4	76978	Bearing for 19195	16	76990	Bearing Seat for 19195	28
76967	Big Chain Pulley Z = 75 for 19195	5	76979	Washer for 19195	17	76991	Bottom Plate for 19195	29
76968	Chain for 19195	6	76980	Washer for 19195	18	76992	Electrical Supporting Plate for 19195	30
76969	Frame for 19195	7	76981	Top Cover for 19195	19	76993	Rubber Foot for 19195	31
76970	Dough Arm for 19195	8	31190	Drive Belt for 19195	20	76994	Bottom Pulley Z = 19 for 19195	32
76971	Shaft for 19195	9	76983	Small Belt Pulley for 19195	21	76995	Tension Pulley Z = 19 for 19195	33
76972	Protective Plate for 19195	10	76984	Motor Fixed Plate for 19195	22	27948	Push-Lock Turn-Reset Switch for 19195	
76973	Center Rod for 19195	11	76985	Back Cover for 19195	23	27945	Micro Computer Controller for 19195	
76974	Chain for 19195	12	76986	Bearing Seat for 19195	24			