



General Purpose Mixer
Model MX-CN-0127
Item 27767
Instruction Manual



Revised - 03/02/2020



Toll Free: 1-800-465-0234
Fax: 905-607-0234
Email: service@omcan.com
www.omcan.com

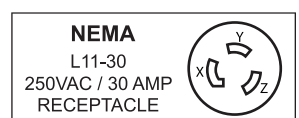

Table of Contents

Model MX-CN-0127

Section	Page
General Information -----	3 - 4
Safety and Warranty -----	4 - 5
Technical Specifications -----	5
Operation -----	6
Maintenance -----	6
Troubleshooting -----	7
Mixer Capacity Chart -----	7
Parts Breakdown -----	8 - 15
Electrical Schematics -----	16
Notes -----	17 - 18
Warranty Registration -----	19



General Information

Omcan Manufacturing and Distributing Company Inc., Food Machinery of America, Inc. dba Omcan and Omcan Inc. are not responsible for any harm or injury caused due to any person's improper or negligent use of this equipment. The product shall only be operated by someone over the age of 18, of sound mind, and not under the influence of any drugs or alcohol, who has been trained in the correct operation of this machine, and is wearing authorized, proper safety clothing. Any modification to the machine voids any warranty, and may cause harm to individuals using the machine or in the vicinity of the machine while in operation.

CHECK PACKAGE UPON ARRIVAL

Upon receipt of an Omcan shipment please inspect for external damage. If no damage is evident on the external packaging, open carton to ensure all ordered items are within the box, and there is no concealed damage to the machine. If the package has suffered rough handling, bumps or damage (visible or concealed), please note it on the bill of lading before accepting the delivery and contact Omcan within 24 hours, so we may initiate a claim with the carrier. A detailed report on the extent of the damage caused to the machine must be filled out within three days, from the delivery date shown in the shipping documents. Omcan has no recourse for damaged products that were shipped collect or third party.

Before operating any equipment, always read and familiarize yourself with all operation and safety instructions.

Omcan would like to thank you for purchasing this machine. It's of the utmost importance to save these instructions for future reference. Also save the original box and packaging for shipping the equipment if servicing or returning of the machine is required.

Omcan Fabrication et distribution Compañie Limité et Food Machinery d'Amérique, dba Omcan et Omcan Inc. ne sont pas responsables de tout dommage ou blessure causé du fait que toute personne ait utilisé cet équipement de façon irrégulière. Le produit ne doit être exploité que par quelqu'un de plus de 18 ans, saine d'esprit, et pas sous l'influence d'une drogue ou d'alcool, qui a été formé pour utiliser cette machine correctement, et est vêtu de vêtements de sécurité approprié. Toute modification de la machine annule toute garantie, et peut causer un préjudice à des personnes utilisant la machine ou des personnes à proximité de la machine pendant son fonctionnement.

VÉRIFIEZ LE COLIS DÈS RÉCEPTION

Dès réception d'une expédition d'Omcan veuillez inspecter pour dommages externes. Si aucun dommage n'est visible sur l'emballage externe, ouvrez le carton afin de s'assurer que tous les éléments commandés sont dans la boîte, et il n'y a aucun dommage dissimulé à la machine. Si le colis n'a subi aucune mauvaises manipulations, de bosses ou de dommages (visible ou cachée), notez-le sur le bond de livraison avant d'accepter la livraison et contactez Omcan dans les 24 heures qui suivent, pour que nous puissions engager une réclamation auprès du transporteur. Un rapport détaillé sur l'étendue des dommages causés à la machine doit être rempli dans un délai de trois jours, à compter de la date de livraison indiquée dans les documents d'expédition. Omcan n'a aucun droit de recours pour les produits endommagés qui ont été expédiés ou cueilli par un tiers transporteur.

General Information

Avant d'utiliser n'importe quel équipement, toujours lire et vous familiariser avec toutes les opérations et les consignes de sécurité.

Omcan voudrais vous remercier d'avoir choisi cette machine. Il est primordial de conserver ces instructions pour une référence ultérieure. Également conservez la boîte originale et l'emballage pour l'expédition de l'équipement si l'entretien ou le retour de la machine est nécessaire.

Omcan Empresa De Fabricacion Y Distribucion Inc. Y Maquinaria De Alimentos De America, Inc. dba Omcan y Omcan Inc. no son responsables de ningun daño o perjuicio causado por cualquier persona inadecuada o el uso descuidado de este equipo. El producto solo podra ser operado por una persona mayor de 18 años, en su sano juicio y no bajo alguna influencia de droga o alcohol, y que este ha sido entrenado en el correcto funcionamiento de esta máquina, y ésta usando ropa apropiada y autorizada. Cualquier modificación a la máquina anula la garantía y puede causar daños a las personas usando la máquina mientras esta en el funcionamiento.

REVISE EL PAQUETE A SU LLEGADA

Tras la recepcion de un envio Omcan favor inspeccionar daños externos. Si no hay daños evidentes en el empaque exterior, Habra el carton para asegurarse que todos los articulos solicitados estén dentro de la caja y no encuentre daños ocultos en la máquina. Si el paquete ha sufrido un manejo de poco cuidado, golpes o daños (visible o oculto) por favor anote en la factura antes de aceptar la entrega y contacte Omcan dentro de las 24 horas, de modo que podamos iniciar una reclamación con la compañía. Un informe detallado sobre los daños causados a la máquina debe ser llenado en el plazo de tres días, desde la fecha de entrega que se muestra en los documentos de envío. Omcan no tiene ningun recurso por productos dañados que se enviaron a recoger por terceros.

Antes de utilizar cualquier equipo, siempre lea y familiarizarse con todas las instrucciones de funcionamiento y seguridad.

Omcan le gustaría darle las gracias por la compra de esta máquina. Es de la mayor importancia para salvar estas instrucciones para futuras consultas. Además, guarda la caja original y el embalaje para el envío del equipo si servicio técnico o devolución de la máquina que se requiere.

Safety and Warranty

IMPORTANT

- The mixer must have good protective grounding.
- Don't operate the mixer beyond the required quantity. When the quantity of water is below 55%, please reduce the flour.
- Do not put the hand into the bowl when operating the mixer.



Safety and Warranty

1 YEAR PARTS AND LABOUR WARRANTY

Within the warranty period, contact Omcan Inc. at 1-800-465-0234 to schedule an Omcan authorized service technician to repair the equipment locally.

Unauthorized maintenance will void the warranty. Warranty covers electrical and part failures, not improper use.

Please see <https://omcan.com/disclaimer> for complete info.

WARNING:

The packaging components are classified as normal solid urban waste and can therefore be disposed of without difficulty.

In any case, for suitable recycling, we suggest disposing of the products separately (differentiated waste) according to the current norms.

DO NOT DISCARD ANY PACKAGING MATERIALS IN THE ENVIRONMENT!

Technical Specifications

Model	MX-CN-0127
Power	2 kW - 3.7 kW / 2.7 HP - 5 HP
Shaft Speed	120 / 240 RPM
Bowl Speed	17 RPM
Bowl Capacity	120 L / 127 QT
Maximum Kneading Capacity	82.6 lbs. / 37.5 kgs.
Electrical	220V / 60Hz / 3
Weight	1080.3 lbs. / 491 kgs.
Dimensions	47.6" x 28.3" x 56.3" / 1210 x 720 x 1430mm
Packaging Weight	1256.5 lbs. / 571.1 kgs.
Packaging Dimensions	49.2" x 30" x 65.6" / 1250 x 762 x 1665mm
Item Number	27767

Operation

The machine has two controls: touch-panel control and manual-switch control.

TOUCH-PANEL CONTROL

- Put the materials into the bowl. Note that sufficient quantity is 55% of bowl volume with flour and water.
- Automatic manner: switch on power supply; set 3-4 minutes at low speed, 7-8 minutes at high speed, and press “manual/automatic switch” to automatic state (“AUTO” light became light on the panel). Then press “ON” to turn on the machine, the machine will mix the flour at one time.
- Manual manner: switch on power supply, press “manual/automatic switch” to manual state (“Manu” light became light on the panel). Press “quack/slow switch” at low speed, and press “ON” switch to start mixing at low speed, and to some extent, press “quick” mixing switch to complete mixing.
- Take out paste after mixing. If turn on the face guard during mixing, then the machines will stop rotating. In this case, press “INCH” switch, then the machine can operate, and the paste can be taken out.

MANUAL-SWITCH CONTROL

The machine has manual switch at the left side, “1” is slow speed, “2” is quick speed. The switch can be turn to the required speed when using, and press the button beside the switch. In the process of manual operation, the power supply of panel is turn off. If you want to use it again, then switch on the power supply again.

The machine has slow or quick reversion function, and it can be used in blending the materials. When taking out the paste, reversion function can’t be used in case of breaking the paste.

At any times, if happens some accidents, press “Emergency Button” to stop the machine quickly to prevent any damage. The machine can be started again after finding out the reasons.

Maintenance

Take out the paste after mixing; wipe the inside of bowl, newel and pole with clean water and cloth. And move the unwanted materials above the bowl with clean cloth. Do not wash the below area of the machine.

- Wipe the panel with clean cloth with litter water; do not use toluene, gas, or any volatile cleaner to clean the panel.
- Do not use nail or other hard things to press the button. Do not wash the panel and switch with water in case of electric shock.
- Make sure the machine works in a stable position, if it has some shakes, then adjust the adjustable foot to make the machine in stable.
- Put the food safe oil into every food safe oil hole in the bearing three months a time.

Troubleshooting

Problem	Possible Cause	Solution
The machine can't start up	No power.	Check the power supply, whether lose phase or not.
	Burnt fuse.	Check the fuse, if burnt, please replace it.
	The switch, emergency button or other buttons are in the close or open position.	Unplug the machine and place all buttons in the off position.
The machine doesn't work normally.	The belt became flexible and slips, or the belt is broken.	Please adjust the belt, or replace the belt.

Mixer Capacity Chart

Ingredients	Dough for Making Heavy Bread	Dough for Making Medium-Weight Pizza	Dough for Making Puffed Donut
Flour	100.0%	100.0%	100.0%
Water	55.0%	50.0%	65.0%
Yeast	2.0%	1.0%	5.0%
Salt	2.5%	1.5%	2.5%
Sugar	5.0%	0%	15.0%
Foam	5.0%	0%	15.0%
Oil	0%	2.0%	0%
Non-Fat Milk Powder	6.0%	0%	8.0%
In Total	175.5%	154.5%	210.5%

REFERENCE

Item Number	Model Number	Description	Manufacturer Model Number
27767	MX-CN-0127	Mixer Spiral Dough 127 QT / 32 Gal 2.7-5 HP / 2013-3728 W 220V/60/3 cETLus INTERTEK	FM60

Parts Breakdown

Model MX-CN-0127 27767

Hook and Motor

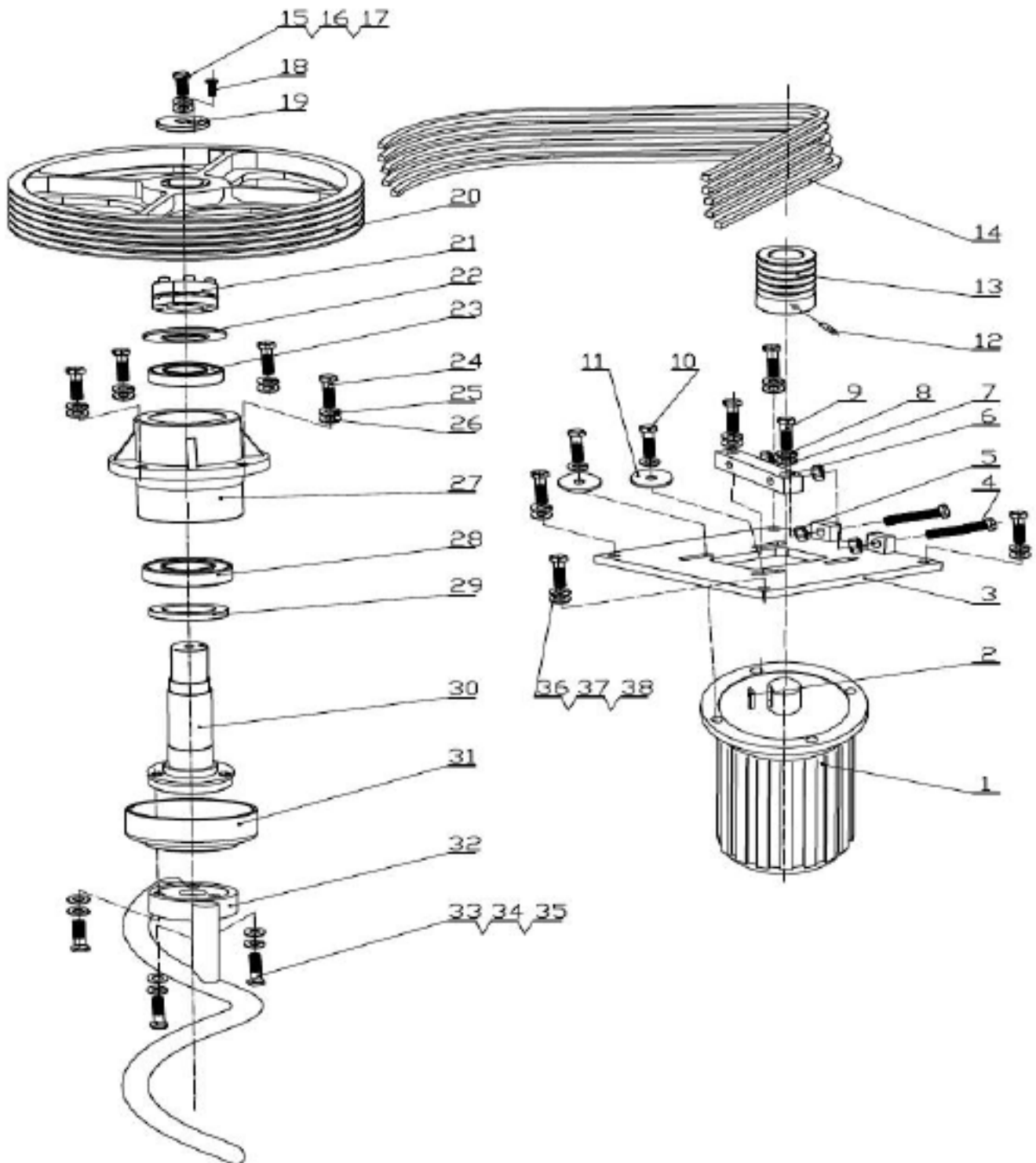

Parts Breakdown

Model MX-CN-0127 27767

Hook and Motor

Item No.	Description	Position	Item No.	Description	Position	Item No.	Description	Position
65298	220V/60HZ/3 Motor and Flat Key 10 for FM60	1+2	65303	Hex Bolt M12x35 for FM60	15	28663	Bearing 33210 for FM60	28
65299	Setting Board for Motor for FM60	3	25047	Flat Pad Φ12 for FM60	16	65315	Clamp Plate 60/88x10 for FM60	29
65300	Bolts M12x120 for FM60	4	25030	Spring Washer Φ12 for FM60	17	65316	Main Shaft for FM60	30
25029	Hex Nut M12 for FM60	5	65308	Socket Head Cap Screw M6x30 for FM60	18	65317	Decorative Cover for FM60	31
65301	Adjust Seat for FM60	6	65309	Shaft Cover for FM60	19	65318	Hook for FM60	32
25047	Flat Pad Φ12 for FM60	7	65310	Main Shaft Half-Axis Belt Wheel for FM60	20	65319	Stainless Steel Hex Bolt M12x50 for FM60	33
25030	Spring Washer Φ12 for FM60	8	65311	Connecting Set 35x60 for FM60	21	65320	Stainless Steel Flat Pad for FM60	34
65302	Hex Bolt M12x55 for FM60	9	65312	Clamp Plate for FM60	22	65321	Stainless Steel Spring Washer Φ12 for FM60	35
65303	Hex Bolt M12x55 for FM60	10	28665	Bearing 6209 for FM60	23	65313	Hex Bolt M12x30 for FM60	36
65304	Clamp Plate Φ12 for FM60	11	65313	Hex Bolt M12x30 for FM60	24	25047	Flat Pad Φ12 for FM60	37
65305	Socket Head Cap Screw M8x16 for FM60	12	25047	Flat Pad Φ12 for FM60	25	25030	Spring Washer Φ12 for FM60	38
65306	Half-Axis Belt Wheel for FM60	13	25030	Spring Washer Φ12 for FM60	26			
65307	Belt 13PL1613 for FM60	14	65314	Main Shaft Seat for FM60	27			

Parts Breakdown

Model MX-CN-0127 27767

Bowl and Motor

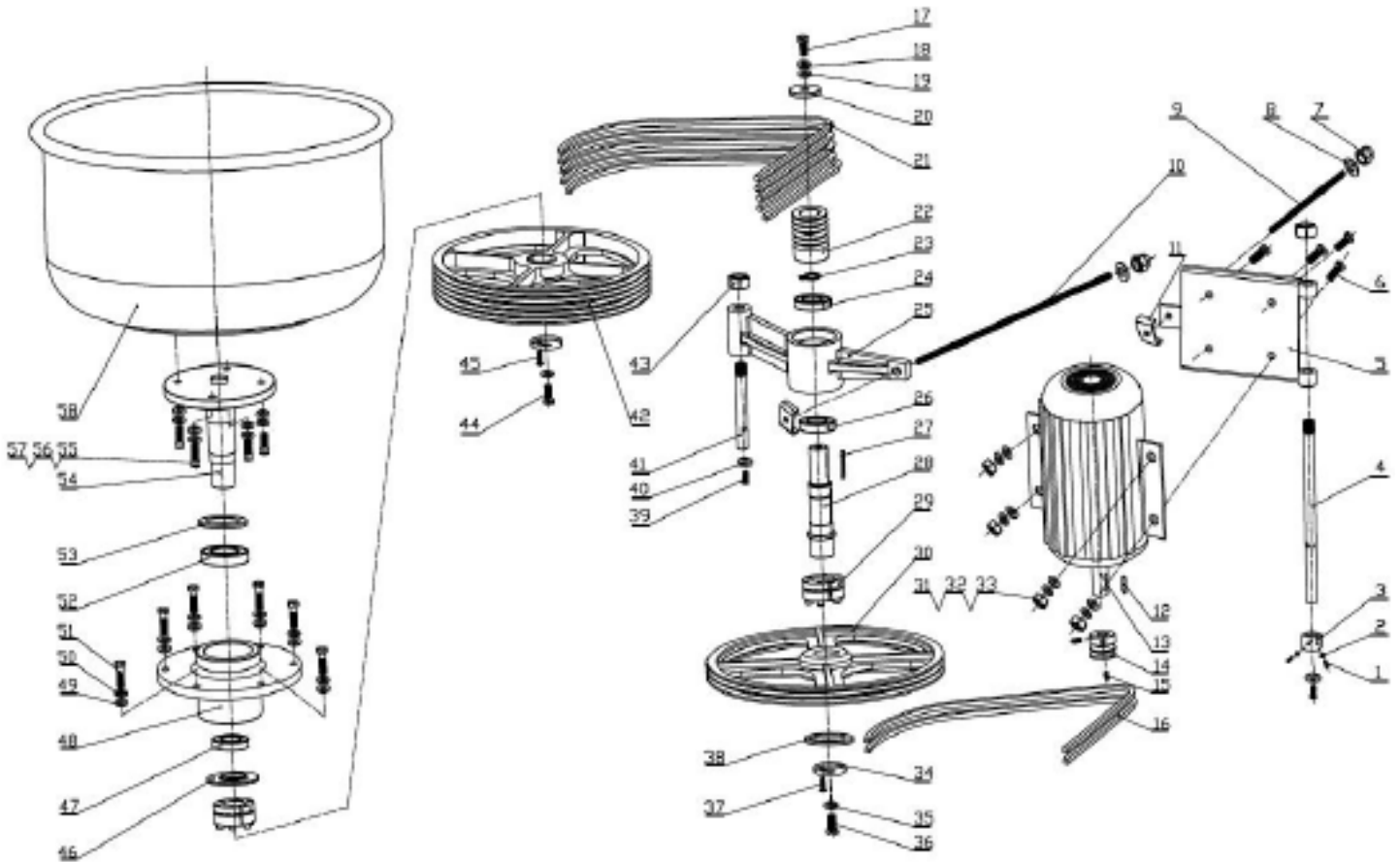

Parts Breakdown

Model MX-CN-0127 27767

Bowl and Motor

Item No.	Description	Position	Item No.	Description	Position	Item No.	Description	Position
65322	Socket Head Cap Screw M8x20 for FM60	1	28662	Belt SPZ1525 for FM60	21	65345	Clamp Plate 28/10.5 for FM60	40
25068	Hex Nut M8 for FM60	2	65335	Motor Belt Wheel for FM60	22	65346	Shaft Seat Axis for FM60	41
65323	Pin Sets for FM60	3	65336	Shaft Ring 40 for FM60	23	65347	Main Shaft Belt Wheel for FM60	42
65324	Spindle for Motor for FM60	4	28664	Bearing 6208 for FM60	24	65348	Nut M20 for FM60	43
65325	Motor Install Seat for FM60	5	65337	Driver Shaft Bearing Seat for FM60	25	65313	Hex Bolt M12x30 for FM60	44
65326	Hex Bolt M10x30 for FM60	6	28664	Bearing 6208 for FM60	26	65308	Socket Head Cap Screw M6x30 for FM60	45
65327	Nut M10 for FM60	7	65338	Flat Key A10x50 for FM60	27	65312	Clamp Plate for FM60	46
65328	Clamp Plate 28/10.5 for FM60	8	65339	Driver Shaft for FM60	28	28665	Bearing 6209 for FM60	47
65329	Short Stem for FM60	9	65311	Connecting Set 45*75 for FM60	29	65349	Bowl Shaft Seat for FM60	48
65330	Long Stem for FM60	10	65340	Big Belt Wheel of Shaft for FM60	30	65320	Stainless Steel Flat Pad Φ 12 for FM60	49
65331	Stem Support for FM60	11	24883	Hex Nut M10 for FM60	31	65321	Stainless Steel Spring Washer Φ 12 for FM60	50
65332	220V/60HZ/3 Motor and Flat Key 6x40 for FM60	12+13	24882	Ring for FM60	32	65350	Stainless Steel Hex Bolt M12x40 for FM60	51
65333	Belt Wheel of Bowl Motor for FM60	14	24939	Flat Pad Φ 10 for FM60	33	28663	Bearing 33210 for FM60	52
65305	Socket Head Cap Screw M8x16 for FM60	15	65309	Shaft Cover for FM60	34	65315	Clamp Plate 60/88x10 for FM60	53
28661	Belt SPZ1462 for FM60	16	25030	Spring Washer Φ 12 for FM60	35	65351	Bowl Shaft Seat for FM60	54
65303	Hex Bolt M12x35 for FM60	17	65342	Hex Bolt M12x40 for FM60	36	65352	Stainless Steel Hex Bolt M12x35 for FM60	55
25030	Spring Washer Φ 12 for FM60	18	65308	Socket Head Cap Screw M6x30 for FM60	37	65321	Stainless Steel Spring Washer Φ 12 for FM60	56
25047	Flat Pad Φ 12 for FM60	19	65343	Clamp Plate for FM60	38	65320	Stainless Steel Flat Pad Φ 12 for FM60	57
65334	Shaft Cover for FM60	20	65344	Hex Bolt M10x20 for FM60	39	65353	Bowl for FM60	58

Parts Breakdown

Model MX-CN-0127 27767

Body Components

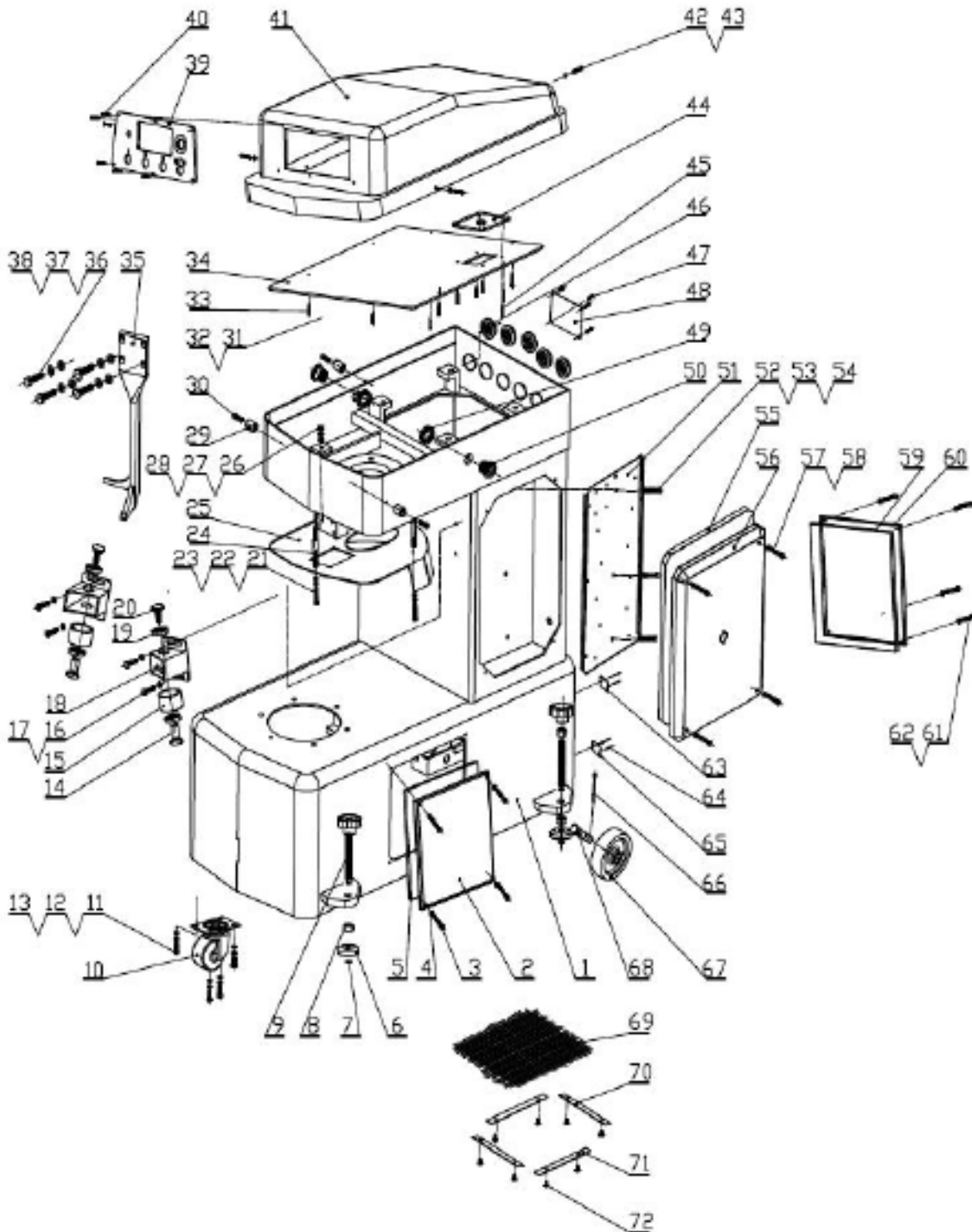

Parts Breakdown

Model MX-CN-0127 27767

Body Components

Item No.	Description	Position	Item No.	Description	Position	Item No.	Description	Position
65354	Chassis Sub-Assembly for FM60	1	65373	Back Protect Guard for FM60	25	65391	Nut M25x1.5 for FM60	49
65355	View Hole Cover for FM60	2	25068	Hex Nut M8 for FM60	26	65392	Fixed Pin Sets for FM60	50
65356	Stainless Steel Hex Bolt M5x20 for FM60	3	65374	Flat Pad Φ8 for FM60	27	65393	Electrical Installation for FM60	51
65357	Stainless Steel Flat Pad Φ5 for FM60	4	25096	Spring Washer Φ8 for FM60	28	65394	Phillips Screw M6x20 for FM60	52
65358	Sealing Tape for FM60	5	65375	Pin Sets for FM60	29	65395	Flat Pad Φ6 for FM60	53
65359	Adjust Feet Support Seat for FM60	6	65376	Stainless Steel Socket Head Cap Screw M8x25 for FM60	30	39316	Spring Washer Φ6 for FM60	54
24898	Shaft Circlips 12 for FM60	7	65377	Phillips Screw M4x10 for FM60	31	65358	Sealing Strip for FM60	55
65360	Stainless Steel Hex Nut M16 for FM60	8	65378	Flat Pad Φ4 for FM60	32	65396	Electronic Control Panel for FM60	56
65361	Planetary Handle M16 for FM60	9	65379	Phillips Screw ST4.2x16 for FM60	33	65397	Stainless Steel Hex Bolt M5x50 for FM60	57
65362	Industrial Wheels 100 for FM60	10	65380	Cover Board for FM60	34	65357	Flat Washer Φ5 for FM60	58
65344	Hex Bolt M10x20 for FM60	11	65381	Fixed Block Shaft for FM60	35	65358	Sealing Strip for FM60	59
24882	Ring for FM60	12	65382	Stainless Steel Hex Bolt M12x30 for FM60	36	65355	View Hole Cover for FM60	60
24939	Flat Pad Φ10 for FM60	13	65320	Stainless Steel Flat Pad Φ12 for FM60	37	65356	Stainless Steel Hex Bolt M5x20 for FM60	61
65363	Block Wheel Shaft for FM60	14	65321	Stainless Steel Spring Washer Φ12 for FM60	38	65357	Stainless Steel Flat Pad Φ5 for FM60	62
65364	Block Wheel Ontology for FM60	15	65383	Button Electronic Control Panel for FM60	39	65398	Belt Tensioner Mark for FM60	63
65365	Stainless Steel Hex Bolt M8x16 for FM60	16	65384	Stainless Steel Phillips Screw ST4.2x19 for FM60	40	65399	Blind Rivets Φ3x9 for FM60	64
65366	Stainless Steel Flat Pad Φ8 for FM60	17	65385	Cover for FM60	41	65400	Rotating Tensioner Mark for FM60	65
65367	Block Wheel Seat for FM60	18	65386	Stainless Steel Phillips Screw M4x10 for FM60	42	65401	Pin 4x50 for FM60	66
25084	Bearing for FM60	19	65387	Nylon Flat Pad Φ4 for FM60	43	65402	Industrial Wheels 110 for FM60	67
65368	Block Wheel Bolts for FM60	20	65388	Wire Fixed Board for FM60	44	65403	Back Wheel Shaft for FM60	68
65369	Stainless Steel Phillips Screw M6x10 for FM60	21	65379	Phillips Screw ST4.2x16 for FM60	45	65404	Stainless Steel Wire Mesh for FM60	69
65370	Stainless Steel Flat Pad Φ6 for FM60	22	65389	Cooling Hole Cover for FM60	46	65405	Wire Mesh Layering for FM60	70
65371	Stainless Steel Spring Washer Φ6 for FM60	23	39345	Stainless Steel Phillips Screw M4x6 for FM60	47	65406	Wire Mesh Layering for FM60	71
65372	Screw for FM60	24	65390	Brand for FM60	48	65407	Stainless Steel Phillips Screw M5x12 for FM60	72

Parts Breakdown

Model MX-CN-0127 27767

Guard

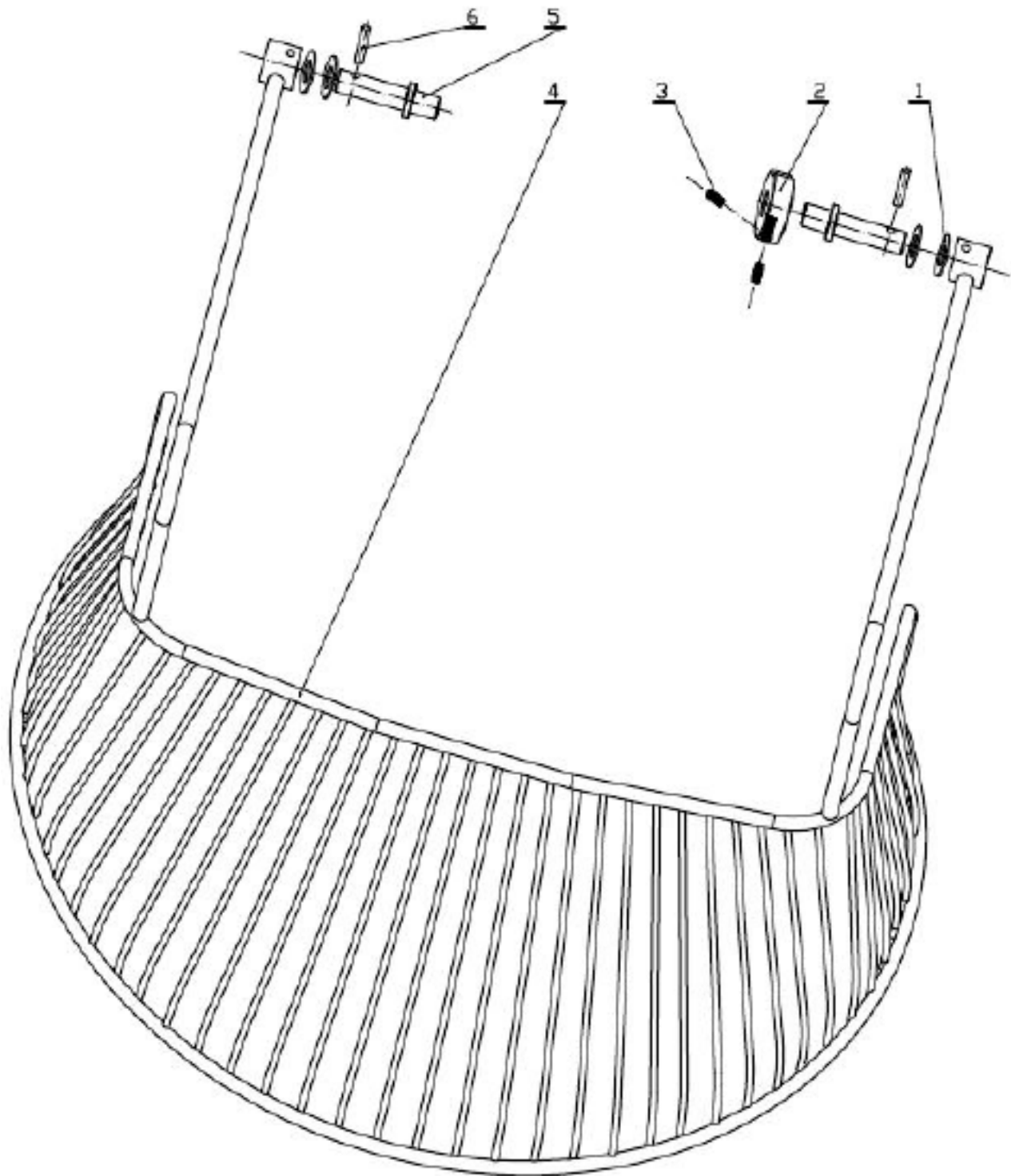



Parts Breakdown

Model MX-CN-0127 27767

Guard

Item No.	Description	Position	Item No.	Description	Position	Item No.	Description	Position
65408	Plate for FM60	1	65410	Switch Block Wheel M6x16 for FM60	3	65412	Pin for FM60	5
65409	Switch Block Wheel for FM60	2	65411	Front Protect Guard for FM60	4	65413	Spring Pin 4x30 for FM60	6

Electrical Schematics

Model MX-CN-0127 27767

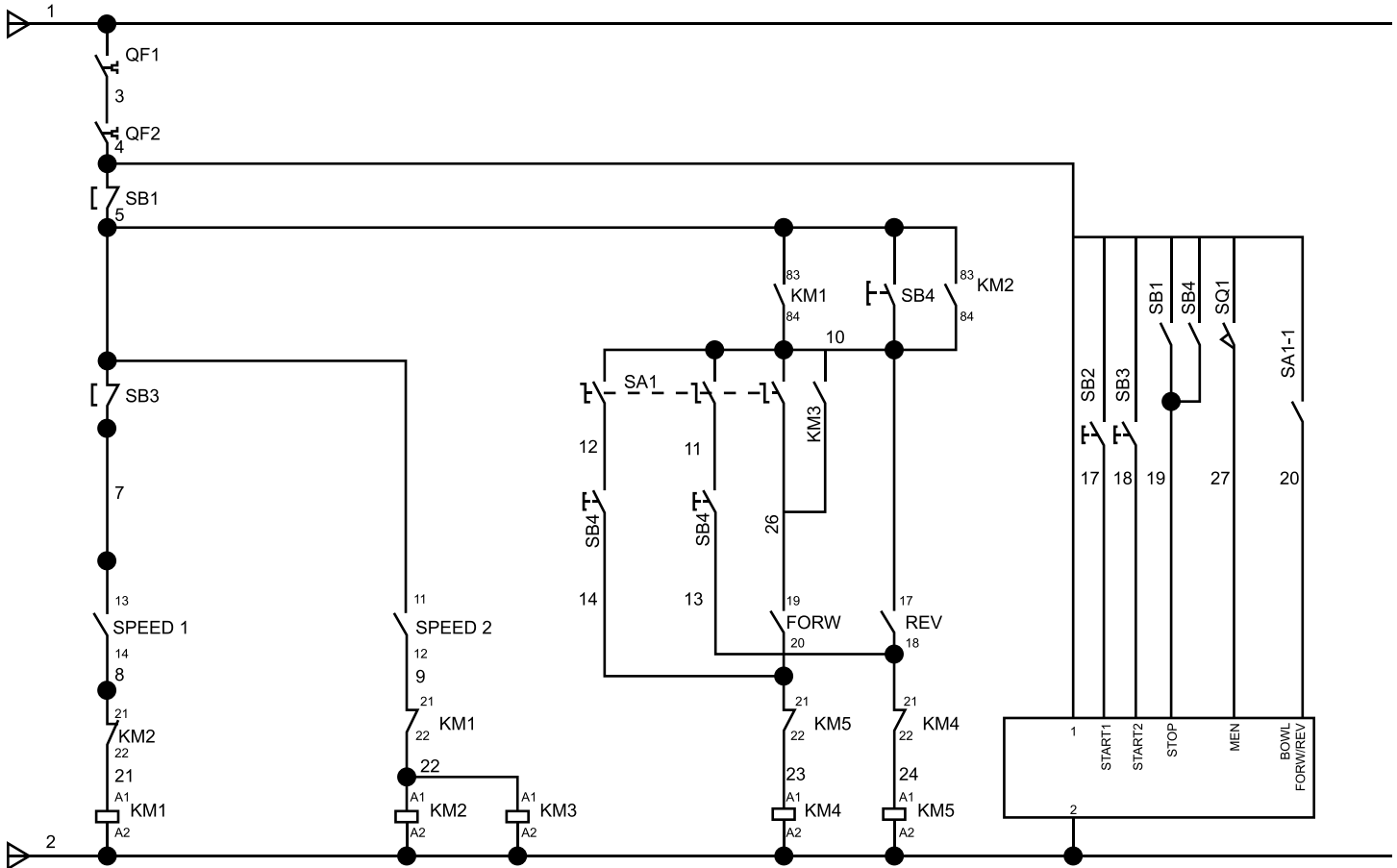



Warranty Registration

Thank you for purchasing an Omcan product. To register your warranty for this product, complete the information below, tear off the card at the perforation and then send to the address specified below. You can also register online by visiting:

Merci d'avoir acheté un produit Omcan. Pour enregistrer votre garantie pour ce produit, complétez les informations ci-dessous, détachez la carte au niveau de la perforation, puis l'envoyer à l'adresse spécifiée ci-dessous. Vous pouvez également vous inscrire en ligne en visitant:

Gracias por comprar un producto Omcan usted. Para registrar su garantía para este producto, complete la información a continuación, cortar la tarjeta en la perforación y luego enviarlo a la dirección indicada a continuación. También puede registrarse en línea en:

<https://omcan.com/warranty-registration/>

For mailing in Canada

Pour postale au Canada

Por correo en Canadá

OMCAN

PRODUCT WARRANTY REGISTRATION

3115 Pepper Mill Court,

Mississauga, Ontario

Canada, L5L 4X5

For mailing in the US

Pour diffusion aux États-Unis

Por correo en los EE.UU.

OMCAN

PRODUCT WARRANTY REGISTRATION

4450 Witmer Industrial Estates, Unit 4,

Niagara Falls, New York

USA, 14305

or email to: service@omcan.com



Purchaser's Information

Name: _____

Address: _____

City: _____ Province or State: _____ Postal or Zip: _____

Country: _____

Dealer from which Purchased: _____

Dealer City: _____ Dealer Province or State: _____

Invoice: _____

Model Name: _____ Model Number: _____

Machine Description: _____

Date of Purchase (MM/DD/YYYY): _____

Would you like to extend the warranty? Yes No

Company Name: _____

Telephone: _____

Email Address: _____

Type of Company:

Restaurant Bakery Deli

Butcher Supermarket Caterer

Institution (*specify*): _____

Other (*specify*): _____

Serial Number: _____

Date of Installation (MM/DD/YYYY): _____

Thank you for choosing Omcan | Merci d'avoir choisi Omcan | Gracias por elegir Omcan



Since 1951 Omcan has grown to become a leading distributor of equipment and supplies to the North American food service industry. Our success over these many years can be attributed to our commitment to strengthen and develop new and existing relationships with our valued customers and manufacturers. Today with partners in North America, Europe, Asia and South America, we continually work to improve and grow the company. We strive to offer customers exceptional value through our qualified local sales and service representatives who provide convenient access to over 5,000 globally sourced products.

Depuis 1951 Omcan a grandi pour devenir un des “leaders” de la distribution des équipements et matériel pour l’industrie des services alimentaires en Amérique du Nord. Notre succès au cours de ces nombreuses années peut être attribué à notre engagement à renforcer et à développer de nouvelles et existantes relations avec nos clients et les fabricants de valeur. Aujourd’hui avec des partenaires en Amérique du Nord, Europe, Asie et Amérique du Sud, nous travaillons continuellement à améliorer et développer l’entreprise. Nous nous efforçons d’offrir à nos clients une valeur exceptionnelle grâce à nos ventes locales qualifiées et des représentants de service qui offrent un accès facile à plus de 5000 produits provenant du monde entier.

Desde 1951 Omcan ha crecido hasta convertirse en un líder en la distribución de equipos y suministros de alimentos en América del Norte industria de servicios. Nuestro éxito en estos años se puede atribuir a nuestro compromiso de fortalecer y desarrollar nuevas relaciones existentes con nuestros valiosos clientes y fabricantes. Hoy con socios de América del Norte, Europa, Asia y América del Sur, que trabajan continuamente para mejorar y crecer la empresa. Nos esforzamos por ofrecer a nuestros clientes valor excepcional a través de nuestro local de ventas y representantes de los servicios que proporcionan un fácil acceso a más de 5,000 productos con origen a nivel mundial.

