



Peelers
Model PE-BR-0010
Item 13443
Instruction Manual



Revised - 06/01/2018



Toll Free: 1-800-465-0234
Fax: 905-607-0234
Email: service@omcan.com
www.omcan.com

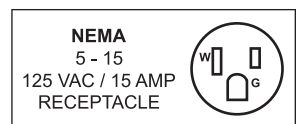

Table of Contents

Model PE-BR-0010

Section	Page
General Information -----	3 - 4
Safety and Warranty -----	4 - 5
Technical Specifications -----	6
Installation -----	6
Operation -----	6 - 7
Maintenance -----	7
Parts Breakdown -----	8 - 10
Electrical Schematics -----	11
Notes -----	12 - 14
Warranty Registration -----	15



General Information

Omcan Manufacturing and Distributing Company Inc., Food Machinery of America, Inc. dba Omcan and Omcan Inc. are not responsible for any harm or injury caused due to any person's improper or negligent use of this equipment. The product shall only be operated by someone over the age of 18, of sound mind, and not under the influence of any drugs or alcohol, who has been trained in the correct operation of this machine, and is wearing authorized, proper safety clothing. Any modification to the machine voids any warranty, and may cause harm to individuals using the machine or in the vicinity of the machine while in operation.

CHECK PACKAGE UPON ARRIVAL

Upon receipt of an Omcan shipment please inspect for external damage. If no damage is evident on the external packaging, open carton to ensure all ordered items are within the box, and there is no concealed damage to the machine. If the package has suffered rough handling, bumps or damage (visible or concealed), please note it on the bill of lading before accepting the delivery and contact Omcan within 24 hours, so we may initiate a claim with the carrier. A detailed report on the extent of the damage caused to the machine must be filled out within three days, from the delivery date shown in the shipping documents. Omcan has no recourse for damaged products that were shipped collect or third party.

Before operating any equipment, always read and familiarize yourself with all operation and safety instructions.

Omcan would like to thank you for purchasing this machine. It's of the utmost importance to save these instructions for future reference. Also save the original box and packaging for shipping the equipment if servicing or returning of the machine is required.

Omcan Fabrication et distribution Compañie Limité et Food Machinery d'Amérique, dba Omcan et Omcan Inc. ne sont pas responsables de tout dommage ou blessure causé du fait que toute personne ait utilisé cet équipement de façon irrégulière. Le produit ne doit être exploité que par quelqu'un de plus de 18 ans, saine d'esprit, et pas sous l'influence d'une drogue ou d'alcool, qui a été formé pour utiliser cette machine correctement, et est vêtu de vêtements de sécurité approprié. Toute modification de la machine annule toute garantie, et peut causer un préjudice à des personnes utilisant la machine ou des personnes à proximité de la machine pendant son fonctionnement.

VÉRIFIEZ LE COLIS DÈS RÉCEPTION

Dès réception d'une expédition d'Omcan veuillez inspecter pour dommages externes. Si aucun dommage n'est visible sur l'emballage externe, ouvrez le carton afin de s'assurer que tous les éléments commandés sont dans la boîte, et il n'y a aucun dommage dissimulé à la machine. Si le colis n'a subi aucune mauvaises manipulations, de bosses ou de dommages (visible ou cachée), notez-le sur le bond de livraison avant d'accepter la livraison et contactez Omcan dans les 24 heures qui suivent, pour que nous puissions engager une réclamation auprès du transporteur. Un rapport détaillé sur l'étendue des dommages causés à la machine doit être rempli dans un délai de trois jours, à compter de la date de livraison indiquée dans les documents d'expédition. Omcan n'a aucun droit de recours pour les produits endommagés qui ont été expédiés ou cueilli par un tiers transporteur.

General Information

Avant d'utiliser n'importe quel équipement, toujours lire et vous familiariser avec toutes les opérations et les consignes de sécurité.

Omcan voudrais vous remercier d'avoir choisi cette machine. Il est primordial de conserver ces instructions pour une référence ultérieure. Également conservez la boîte originale et l'emballage pour l'expédition de l'équipement si l'entretien ou le retour de la machine est nécessaire.

Omcan Empresa De Fabricacion Y Distribucion Inc. Y Maquinaria De Alimentos De America, Inc. dba Omcan y Omcan Inc. no son responsables de ningun daño o perjuicio causado por cualquier persona inadecuada o el uso descuidado de este equipo. El producto solo podra ser operado por una persona mayor de 18 años, en su sano juicio y no bajo alguna influencia de droga o alcohol, y que este ha sido entrenado en el correcto funcionamiento de esta máquina, y ésta usando ropa apropiada y autorizada. Cualquier modificación a la máquina anula la garantía y puede causar daños a las personas usando la máquina mientras esta en el funcionamiento.

REVISE EL PAQUETE A SU LLEGADA

Tras la recepcion de un envio Omcan favor inspeccionar daños externos. Si no hay daños evidentes en el empaque exterior, Habra el carton para asegurarse que todos los articulos solicitados estén dentro de la caja y no encuentre daños ocultos en la máquina. Si el paquete ha sufrido un manejo de poco cuidado, golpes o daños (visible o oculto) por favor anote en la factura antes de aceptar la entrega y contacte Omcan dentro de las 24 horas, de modo que podamos iniciar una reclamación con la compañía. Un informe detallado sobre los daños causados a la máquina debe ser llenado en el plazo de tres días, desde la fecha de entrega que se muestra en los documentos de envío. Omcan no tiene ningun recurso por productos dañados que se enviaron a recoger por terceros.

Antes de utilizar cualquier equipo, siempre lea y familiarizarse con todas las instrucciones de funcionamiento y seguridad.

Omcan le gustaría darle las gracias por la compra de esta máquina. Es de la mayor importancia para salvar estas instrucciones para futuras consultas. Además, guarda la caja original y el embalaje para el envío del equipo si servicio técnico o devolución de la máquina que se requiere.

Safety and Warranty

MAIN PRECAUTIONS

- The Peeler must be used and handled with care.
- BEFORE cleaning disconnect machine from power source.
- NEVER use tools not belonging to machine to help operation.
- The abrasive plate must be perfectly fitted onto central shaft pin.
- BE CAREFUL when handling the abrasive plate, it is heavy and may hurt if dropped.



Safety and Warranty

- DO NOT put your hands inside machine during operation.
- NEVER connect power source with wet hands nor wet clothes.
- NEVER spray water or other liquid substances directly at motor, power switch or any other electrical components.
- ALWAYS install equipment in working area with adequate light and space away from children and visitors.
- NEVER operate without all warning labels attached and owner/operator manual available to operator.
- NEVER leave unattended while operating.
- ALWAYS ground machine properly.
- DO NOT process frozen foods or other products other than potatoes and carrots.
- NEVER lift lid before being sure abrasive plate is completely still.

GENERAL ADVICE

- ALWAYS turn machine off before cleaning and maintenance.
- PROVIDE enough space around machine to avoid accidents.
- ALWAYS keep the floor dry. Wet floors may cause slips.
- ALWAYS turn machine off in case of power supply lack.
- NEVER let dust or water to get into electrical and mechanical components of the machine.
- DO NOT modify original features of the machine.
- DO NOT take out nor tear off any safety or identification label.

1 YEAR PARTS AND LABOUR BENCH WARRANTY

Within the warranty period, contact Omcan Inc. at 1-800-465-0234 to schedule a drop off to either an Omcan authorized service depot in the area, or to an Omcan Service warehouse to repair the equipment.

Unauthorized maintenance will void the warranty. Warranty covers electrical and part failures, not improper use.

Please see www.omcan.com/warranty.html for complete info.

WARNING:

The packaging components are classified as normal solid urban waste and can therefore be disposed of without difficulty.

In any case, for suitable recycling, we suggest disposing of the products separately (differentiated waste) according to the current norms.

DO NOT DISCARD ANY PACKAGING MATERIALS IN THE ENVIRONMENT!

Technical Specifications

Model	PE-BR-0010
Horsepower	0.5 HP
Capacity	22 lbs.
Output (approx.)	440 lbs/hr.
Electrical	110V/60/1
Weight	75 lbs.
Dimensions	22.8" x 19" x 28"
Item Number	13443

Installation

The peeler must be installed on a level, non-skid work surface. During peeling operation food product must be wet. By means of a 3/4" pipe bring water to feeding nipple. As an alternative it is possible to place the machine below a 3/4" water faucet and let the water flow in during the operation. It is recommended to place the machine near by a water sink to allow wastes to flow out. A drainage pipe may be connected to outlet waste to flow the wastes out to the nearest sink.

Operation

PRE OPERATION

- Check voltage of the machine. The voltage must be the same as the power source voltage.
- Grounding wire must always be connected.
- Check if the machine is firm in its position. Be sure the water inlet pipe and the drainage pipe are installed properly.

OPERATION

IMPORTANT: BE SURE THE ABRASIVE PLATE IS FIRMLY FITTED ONTO CENTRAL SHAFT PIN.

First of all check if the lid is duly fitted on the top of the machine. To start machine turn switch to ON position. Let water flows into the chamber and load it with food product. Water shall then flow out through the waste outlet. Each load shall not exceed 10 Kg in the Peeler. The peeling time is from 3 to 5 minutes it depends on the hardness of the food product, its size and irregularity.

Check if products are peeled looking through the transparent lid. To remove peeled product from inside the chamber close faucet, place a container under the discharge door and open it, so that the peeled potatoes are

Operation

discharged from the chamber under the action of centrifugal force applied by the peeling disc.

IMPORTANT

Under no circumstances touch the Abrasive Disc when it is in moving. Secure the lid, open the water tap, set the timer and activate the ON/OFF switch. With the machine on and with water falling at the center of the abrasive disc, pour the product to be processed inside it. For the PE-BR-0010, put 10 Kg of potatoes at most. The working time varies from one to five minutes. If the potatoes are being peeled to irregularly, it is possible to observe the process through the lid opening. The PE-BR-0010 is designed to process normal shaped potatoes, any other vegetable with irregular shape will need a manual finishing even after processing. To remove the peeled product, keep the machine running, shut down the water and open the Door by pulling the lock upwards. Lift it until the side lock and keep the door open. This way the product will be expelled. To close the door, release the side lock by pulling it sideways.

Maintenance

CLEANING

1. Turn OFF the machine and disconnect it from power source.
2. Wait until the abrasive plate is completely still.
3. To lift the abrasive plate out of the cylinder, hold it and pull it up.
4. Wash the machine and the plate with water and neutral soap.
5. To reassemble plate proceed inversely being sure of placing it back on the central shaft pin correctly.

For a fast cleaning, just turn the machine ON without load and let it work with running water.

REFERENCE

Item Number	Model Number	Description	Manufacturer Model Number
13443	PE-BR-0010	Peeler Potato 22 LB / 10 KG 0.5 HP / 373 W 110V/60/1	DB10

Parts Breakdown

Model PE-BR-0010 13443

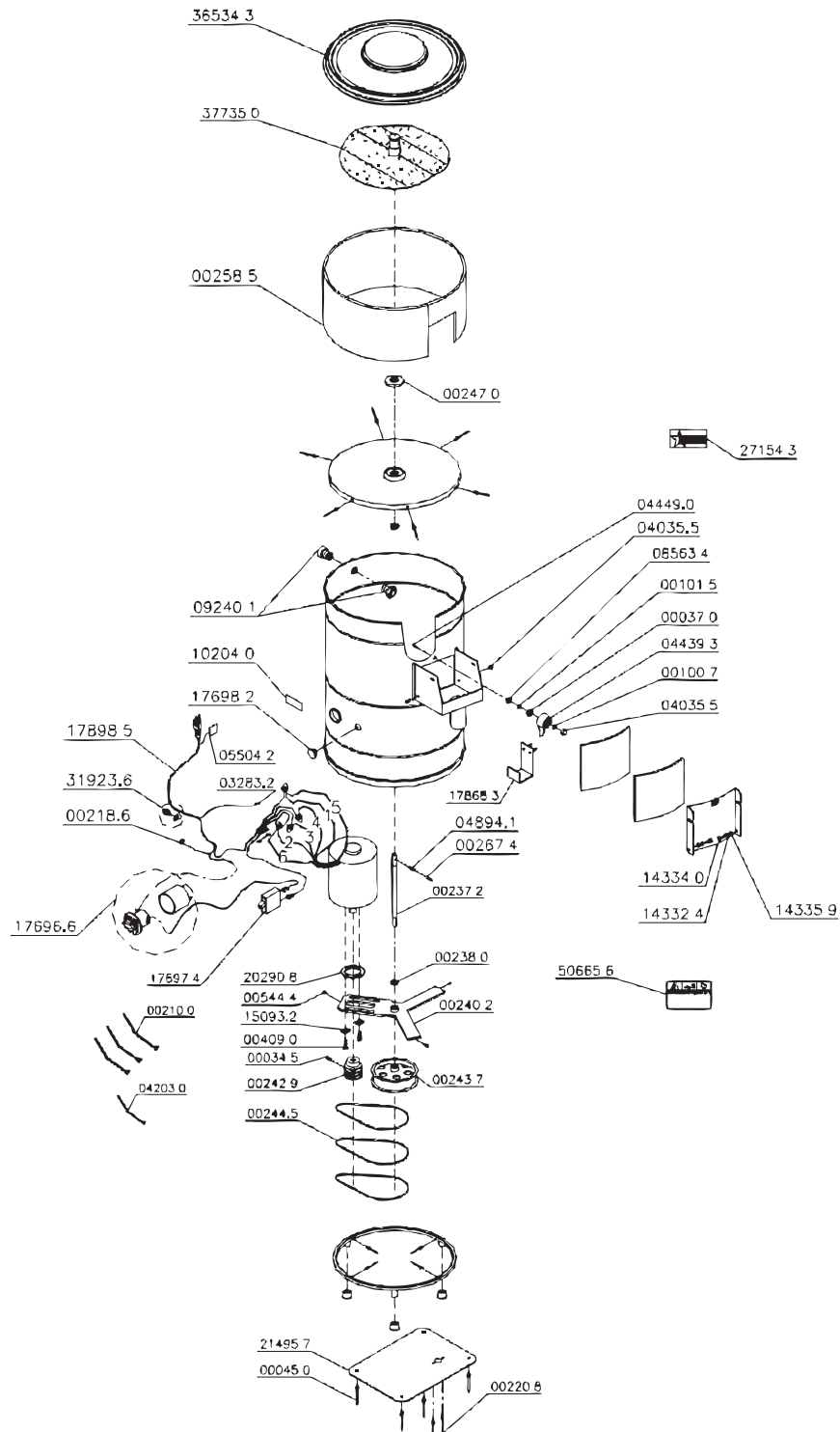

Parts Breakdown

Model PE-BR-0010 13443

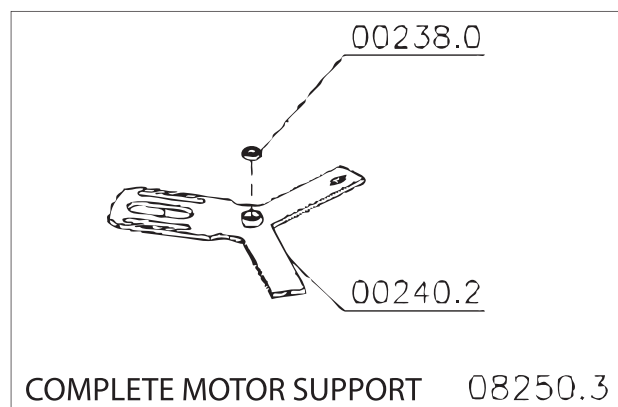
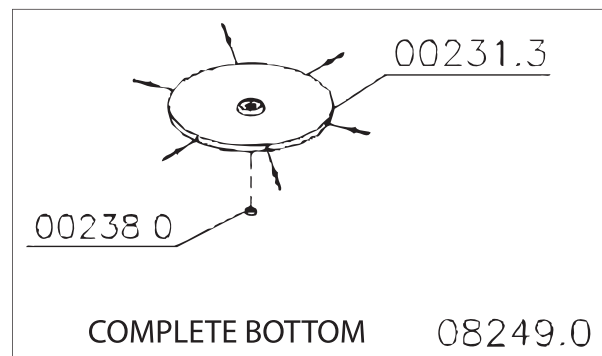
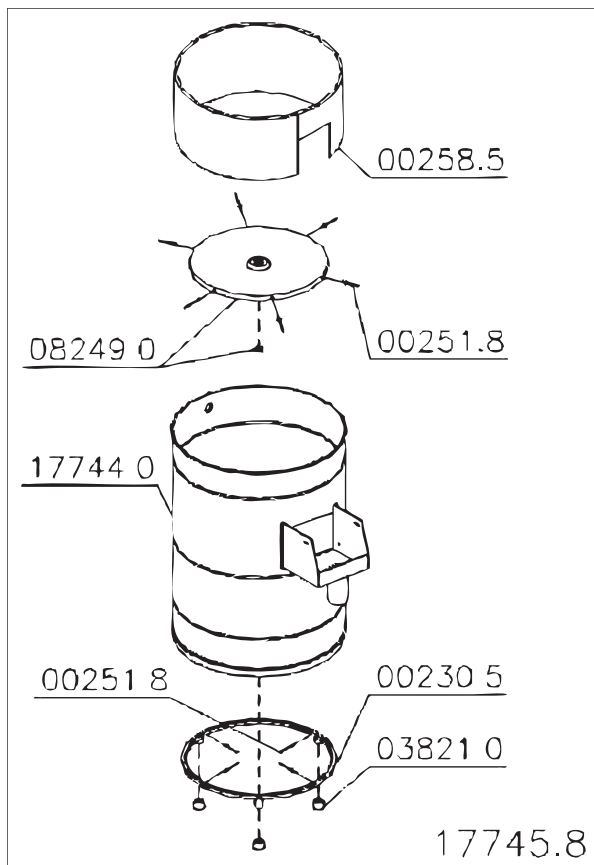
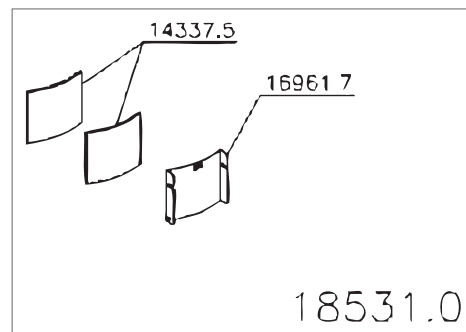
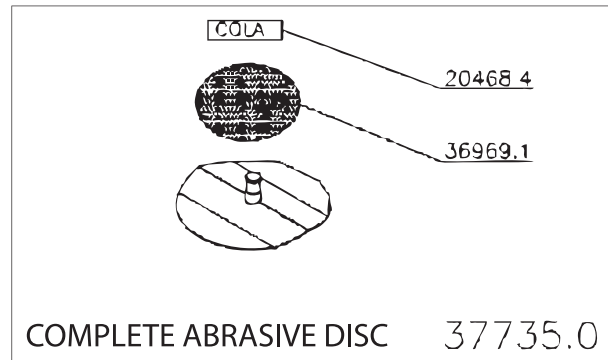
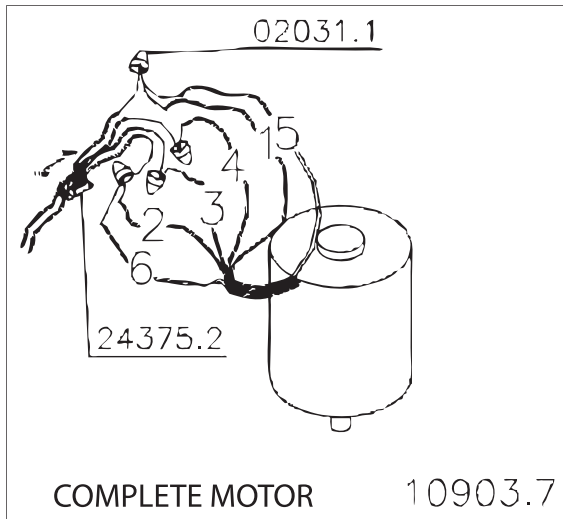

Parts Breakdown

Model PE-BR-0010 13443

Item No.	Description	Position	Item No.	Description	Position	Item No.	Description	Position
30319	Screw 1/4x3/8 for DB10	00034.5	66186	Term. Pre-Isol.AN-2434 for DB10	03283.2	38118	Complete Cabinet for DB10	14990.0
30257	Nut UNC 1 4 ZB for DB10	00037.0	16404	Pont Ext Ted 7/8 for DB10	03821.0	38107	CS Cabinet for DB10	14991.8
38119	Washer L 1 2 ZB for DB10	00038.8	30341	Screw Nut 1 4 for DB10	04035.5	30222	Washer 2 78x7x20x25mm for DB10	15093.2
30029	Pression Rivet AD-423-S for DB10	00045.0	30245	Latch for DB10	04439.3	78557	Motor 0.5HP 60HZ for DB10	16203.5
30234	Washer L 1/4x1 6 ZB for DB10	00100.7	38126	Pivo da Porta C Zinc. for DB10	04448.2	38045	Washer L.A3.2 DIN 125 Stainless Steel for DB10	17181.6
30270	Washer L 3 8 ZB for DB10	00101.5	30292	PFS FCH UNC1 4x1.1 2 RTZB for DB10	04449.0	79037	Positive Terminal Lock for DB10	17581.1
30186	Wire Passer Molde 0922231 for DB10	00218.6	38127	Tube de Saida (C.Martel.) for DB10	04458.0	30050	Terminal Cover for DB10	17582.0
66182	Pressure Rivet AD-440-S for DB10	00220.8	21579	Central Shaft Pin for DB10	04623.0	16440	On/Off Switch for DB10	17696.6
38120	Cabinet DB 10 for DB10	00228.3	30194	Reduction Bush for DB10	04626.4	16441	Reset Switch (Breaker) for DB10	17697.4
30354	Peeler Base for DB10	00230.5	27710	Glue Kit DB/DP-10/DC for DB10	04636.1	78572	Plug Sext.M32 Black for DB10	17698.2
38117	Base DB 10 for DB10	00231.3	14801	Central Shaft Pin for DB10	04894.1	30182	Cord 3x1mm2 2PC1PR Omcan for DB10	17699.0
62452	Central Shaft for DB10	00237.2	66187	Locking Plate Inf. for DB10	05045.8	78549	CS Housing for DB10	17744.0
78569	Ball Bearing 6204 Z for DB10	00238.0	16409	DB10 Lid (Acrylic) for DB10	08174.4	78553	Complete Housing for DB10	17745.8
38110	Motor Base DB 10 for DB10	00240.2	38116	Complete Base for DB10	08249.0	78561	Screw M3x30 for DB10	17814.4
38121	PFS SEX UNC3 8x1 RTZB for DB10	00241.0	16410	Complete Motor Support for DB10	08250.3	78548	Strip for DB10	17868.3
30312	Motor Pulley for DB10	00242.9	38129	PFS FCH UNC1 4x5 8 RTZB for DB10	08521.9	78556	PVC Gloove 1/2 NPT Grey EL for DB10	17891.8
66183	Moved Pulley for DB10	00243.7	38130	Door Base for DB10	08522.7	30305	Cable 3x1.0mm With Plug for DB10	17898.5
66184	Belt Z 625 for DB10	00244.5	30286	Washer 10x28x1.5mm for DB10	08563.4	38114	Door with Rubber for DB10	18531.0
16399	Rubber Flange S027057EAL Mold 085286 for DB10	00247.0	65887	Cord 3x1mm2C/PGRE 2PC1PR for DB10	09102.2	38341	Washer 1/4x5/8x1.2mm Stainless Steel for DB10	19384.4
30352	Pression Rivet AD 665 S for DB10	00251.8	24020	Nipple Set/Reduction for DB10	09240.1	66189	Complete Motor 0.5CV 60HZ W for DB10	19413.1
66185	Revest.Bor.1300x265x6mm for DB10	00258.5	38131	Term. Pre Isol.ET 4259(C) for DB10	09660.1	78564	Nut NPT 1/2x17mm for DB10	19624.0
16395	Lock Pin for DB10	00267.4	38132	Hatch Latch Set with Revetment for DB10	10079.0	38111	Double Ring Adapter for DB10	20143.0
38123	Screw Nut 3 16 for DB10	00319.0	38133	Complete Cabinet for DB10	10708.5	78543	Lower Closing Strip for DB10	21495.7
30277	Switch 14223 A1B1E3G for DB10	00357.3	17512	Abrasive Disc for DB10	10711.5	65886	Motor 0.5CV 60Hz W for DB10	21952.5
38113	PFS SEX UNC1 4x1.1 4 RTZB for DB10	00409.0	66188	Complete Motor 0.5CV 60HZ W for DB10	10903.7	18949	Select Switch 110/220V Compl. for DB10	24375.2
38112	Screw 1 4x5 8 for DB10	00544.4	38044	Nut M3 DIN 934 Stainless Steel for DB10	12853.8	27720	Omcan Logo (Machines) for DB10	27154.3
38124	Complete Cabinet DB 10 for DB10	00692.0	38134	Door for DB10	14313.8	30059	Omcan Packaging Logo for DB10	27155.1
27692	Insult Term EF-4228 for DB10	01213.0	38135	Fastener for DB10	14315.4	66190	Complete Motor 0.5CV 60HZ for DB10	29065.3
30215	Switch HH-201 SF1G3FS1Q for DB10	01307.2	30200	Distanciador for DB10	14332.4	27726	Cord Holder PG13.5 LC+P/9 for DB10	31923.6
16401	Retainer Seal 00784BR1(F.0122) for DB10	01741.8	38136	Screw 3 16x5 16 for DB10	14333.2	44896	Acrylic Lid for DB10	36534.3
30249	On / Off Label for DB10	01844.9	30347	Sextavated Screw UNC1 4x1 RTIN for DB10	14334.0	27762	Oxido de Alumínio No.46 for DB10	36969.1
30350	Nylon Cover CN-4472 for DB10	02031.1	30311	Nut Sex. 1 4 Stainless Steel for DB10	14335.9	38106	Abrasive Disc Small for DB10	37737.6
27693	Washer L.A8.4 ZB for DB10	02730.8	38115	Borracha de Vedacao for DB10	14337.5	30375	Arr.LA21 DIN 125 Inox for DB10	40587.6
38125	PFS FCH UNC1 4x1 2 RTZB for DB10	03210.7	38137	Washer L 3 16 for DB10	14352.9	78551	Cleaning Maintenance Label for DB10	50665.6

Electrical Schematics

Model PE-BR-0010 13443

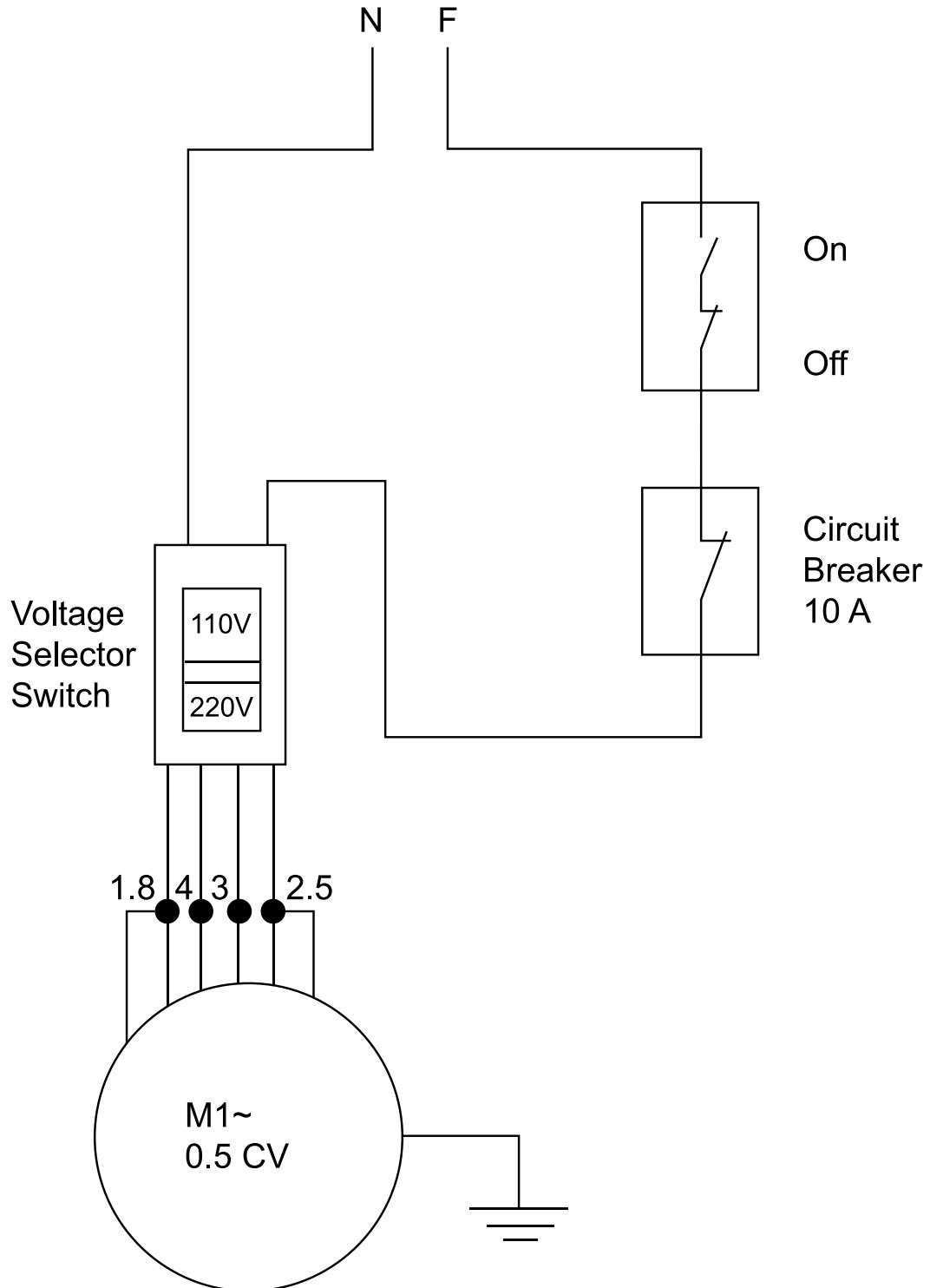



Warranty Registration

Thank you for purchasing an Omcan product. To register your warranty for this product, complete the information below, tear off the card at the perforation and then send to the address specified below. You can also register online by visiting:

Merci d'avoir acheté un produit Omcan. Pour enregistrer votre garantie pour ce produit, complétez les informations ci-dessous, détachez la carte au niveau de la perforation, puis l'envoyer à l'adresse spécifiée ci-dessous. Vous pouvez également vous inscrire en ligne en visitant:

Gracias por comprar un producto Omcan usted. Para registrar su garantía para este producto, complete la información a continuación, cortar la tarjeta en la perforación y luego enviarlo a la dirección indicada a continuación. También puede registrarse en línea en:

www.omcan.com/warrantyregistration.html

For mailing in Canada

Pour postale au Canada

Por correo en Canadá

For mailing in the US

Pour diffusion aux États-Unis

Por correo en los EE.UU.

OMCAN

PRODUCT WARRANTY REGISTRATION

3115 Pepper Mill Court,

Mississauga, Ontario

Canada, L5L 4X5

OMCAN

PRODUCT WARRANTY REGISTRATION

4450 Witmer Industrial Estates, Unit 4,

Niagara Falls, New York

USA, 14305

or email to: service@omcan.com



Purchaser's Information

Name: _____

Address: _____

City: _____ Province or State: _____ Postal or Zip: _____

Country: _____

Dealer from which Purchased: _____

Dealer City: _____ Dealer Province or State: _____

Invoice: _____

Model Name: _____ Model Number: _____

Machine Description: _____

Date of Purchase (MM/DD/YYYY): _____

Would you like to extend the warranty? Yes No

Company Name: _____

Telephone: _____

Email Address: _____

Type of Company:

Restaurant Bakery Deli

Butcher Supermarket Caterer

Institution (specify): _____

Other (specify): _____

Serial Number: _____

Date of Installation (MM/DD/YYYY): _____

Thank you for choosing Omcan | Merci d'avoir choisi Omcan | Gracias por elegir Omcan



Since 1951 Omcan has grown to become a leading distributor of equipment and supplies to the North American food service industry. Our success over these many years can be attributed to our commitment to strengthen and develop new and existing relationships with our valued customers and manufacturers. Today with partners in North America, Europe, Asia and South America, we continually work to improve and grow the company. We strive to offer customers exceptional value through our qualified local sales and service representatives who provide convenient access to over 3,500 globally sourced products.

Depuis 1951 Omcan a grandi pour devenir un des “leaders” de la distribution des équipements et matériel pour l’industrie des services alimentaires en Amérique du Nord. Notre succès au cours de ces nombreuses années peut être attribué à notre engagement à renforcer et à développer de nouvelles et existantes relations avec nos clients et les fabricants de valeur. Aujourd’hui avec des partenaires en Amérique du Nord, Europe, Asie et Amérique du Sud, nous travaillons continuellement à améliorer et développer l’entreprise. Nous nous efforçons d’offrir à nos clients une valeur exceptionnelle grâce à nos ventes locales qualifiées et des représentants de service qui offrent un accès facile à plus de 3500 produits provenant du monde entier.

Desde 1951 Omcan ha crecido hasta convertirse en un líder en la distribución de equipos y suministros de alimentos en América del Norte industria de servicios. Nuestro éxito en estos años se puede atribuir a nuestro compromiso de fortalecer y desarrollar nuevas relaciones existentes con nuestros valiosos clientes y fabricantes. Hoy con socios de América del Norte, Europa, Asia y América del Sur, que trabajan continuamente para mejorar y crecer la empresa. Nos esforzamos por ofrecer a nuestros clientes valor excepcional a través de nuestro local de ventas y representantes de los servicios que proporcionan un fácil acceso a más de 3,500 productos con origen a nivel mundial.

