



***Sandwich Grill with Timer***  
***Model PG-CN-0711-RT***  
***Item 42914***  
***Instruction Manual***



*Revised - 08/11/2017*



Toll Free: 1-800-465-0234  
Fax: 905-607-0234  
Email: [service@omcan.com](mailto:service@omcan.com)  
[www.omcan.com](http://www.omcan.com)

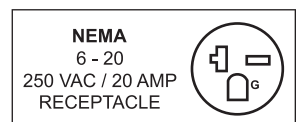

# ***Table of Contents***

Model PG-CN-0711-RT

---

<b>Section</b>	<b>Page</b>
General Information -----	3 - 4
Safety and Warranty -----	4 - 5
Technical Specifications -----	6
Installation -----	6
Operation -----	6 - 7
Maintenance -----	7 - 8
Parts Breakdown -----	8 - 9
Electrical Schematics -----	10
Warranty Registration -----	11



# General Information

---

Omcan Manufacturing and Distributing Company Inc., Food Machinery of America, Inc. dba Omcan and Omcan Inc. are not responsible for any harm or injury caused due to any person's improper or negligent use of this equipment. The product shall only be operated by someone over the age of 18, of sound mind, and not under the influence of any drugs or alcohol, who has been trained in the correct operation of this machine, and is wearing authorized, proper safety clothing. Any modification to the machine voids any warranty, and may cause harm to individuals using the machine or in the vicinity of the machine while in operation.

## CHECK PACKAGE UPON ARRIVAL

Upon receipt of an Omcan shipment please inspect for external damage. If no damage is evident on the external packaging, open carton to ensure all ordered items are within the box, and there is no concealed damage to the machine. If the package has suffered rough handling, bumps or damage (visible or concealed), please note it on the bill of lading before accepting the delivery and contact Omcan within 24 hours, so we may initiate a claim with the carrier. A detailed report on the extent of the damage caused to the machine must be filled out within three days, from the delivery date shown in the shipping documents. Omcan has no recourse for damaged products that were shipped collect or third party.

**Before operating any equipment, always read and familiarize yourself with all operation and safety instructions.**

Omcan would like to thank you for purchasing this machine. It's of the utmost importance to save these instructions for future reference. Also save the original box and packaging for shipping the equipment if servicing or returning of the machine is required.

---

Omcan Fabrication et distribution Compañie Limité et Food Machinery d'Amérique, dba Omcan et Omcan Inc. ne sont pas responsables de tout dommage ou blessure causé du fait que toute personne ait utilisé cet équipement de façon irrégulière. Le produit ne doit être exploité que par quelqu'un de plus de 18 ans, saine d'esprit, et pas sous l'influence d'une drogue ou d'alcool, qui a été formé pour utiliser cette machine correctement, et est vêtu de vêtements de sécurité approprié. Toute modification de la machine annule toute garantie, et peut causer un préjudice à des personnes utilisant la machine ou des personnes à proximité de la machine pendant son fonctionnement.

## VÉRIFIEZ LE COLIS DÈS RÉCEPTION

Dès réception d'une expédition d'Omcan veuillez inspecter pour dommages externes. Si aucun dommage n'est visible sur l'emballage externe, ouvrez le carton afin de s'assurer que tous les éléments commandés sont dans la boîte, et il n'y a aucun dommage dissimulé à la machine. Si le colis n'a subi aucune mauvaises manipulations, de bosses ou de dommages (visible ou cachée), notez-le sur le bond de livraison avant d'accepter la livraison et contactez Omcan dans les 24 heures qui suivent, pour que nous puissions engager une réclamation auprès du transporteur. Un rapport détaillé sur l'étendue des dommages causés à la machine doit être rempli dans un délai de trois jours, à compter de la date de livraison indiquée dans les documents d'expédition. Omcan n'a aucun droit de recours pour les produits endommagés qui ont été expédiés ou cueilli par un tiers transporteur.

# General Information

---

Avant d'utiliser n'importe quel équipement, toujours lire et vous familiariser avec toutes les opérations et les consignes de sécurité.

Omcan voudrais vous remercier d'avoir choisi cette machine. Il est primordial de conserver ces instructions pour une référence ultérieure. Également conservez la boîte originale et l'emballage pour l'expédition de l'équipement si l'entretien ou le retour de la machine est nécessaire.

---

Omcan Empresa De Fabricacion Y Distribucion Inc. Y Maquinaria De Alimentos De America, Inc. dba Omcan y Omcan Inc. no son responsables de ningun daño o perjuicio causado por cualquier persona inadecuada o el uso descuidado de este equipo. El producto solo podra ser operado por una persona mayor de 18 años, en su sano juicio y no bajo alguna influencia de droga o alcohol, y que este ha sido entrenado en el correcto funcionamiento de esta máquina, y ésta usando ropa apropiada y autorizada. Cualquier modificación a la máquina anula la garantía y puede causar daños a las personas usando la máquina mientras esta en el funcionamiento.

## REVISE EL PAQUETE A SU LLEGADA

Tras la recepcion de un envio Omcan favor inspeccionar daños externos. Si no hay daños evidentes en el empaque exterior, Habra el carton para asegurarse que todos los articulos solicitados estén dentro de la caja y no encuentre daños ocultos en la máquina. Si el paquete ha sufrido un manejo de poco cuidado, golpes o daños (visible o oculto) por favor anote en la factura antes de aceptar la entrega y contacte Omcan dentro de las 24 horas, de modo que podamos iniciar una reclamación con la compañía. Un informe detallado sobre los daños causados a la máquina debe ser llenado en el plazo de tres días, desde la fecha de entrega que se muestra en los documentos de envío. Omcan no tiene ningun recurso por productos dañados que se enviaron a recoger por terceros.

Antes de utilizar cualquier equipo, siempre lea y familiarizarse con todas las instrucciones de funcionamiento y seguridad.

Omcan le gustaría darle las gracias por la compra de esta máquina. Es de la mayor importancia para salvar estas instrucciones para futuras consultas. Además, guarda la caja original y el embalaje para el envío del equipo si servicio técnico o devolución de la máquina que se requiere.

# Safety and Warranty

---

## WARNING

## PLEASE READ THE USER MANUAL CAREFULLY BEFORE OPERATING THE MACHINE

This manual has been prepared to enable the correct installation, regulation and maintenance of the unit. It is therefore of basic importance that the warnings contained in this booklet are carefully read as they supply essential indications regarding the safety of the installation, use and maintenance. The appliance must be

# Safety and Warranty

---

installed, tested and serviced by qualified personnel only. Any adjustment whatsoever not expressly authorized and in disrespect of this manual voids the warranty. Observe all existing local regulations at the time of installation. The packing materials (plastic bags, polystyrene, nails, etc.) as potential hazards, must be kept out of the reach of children and properly recycled according to the existing local regulations. For repairs contact Omcan and request the use of original spare parts. If in doubt do not use the appliance and contact Omcan. Not following the above conditions could risk the safety of those using the unit.

**Caution:**

- Please take notice that the unit will still be too hot to handle immediately after use.
- The Contact Grill has a thermal cut-off safety device to avoid over heating.
- If the power cord is damaged, it must be replaced by qualified technician.

## 1 YEAR PARTS AND LABOUR BENCH WARRANTY

Within the warranty period, contact Omcan Inc. at 1-800-465-0234 to schedule a drop off to either an Omcan authorized service depot in the area, or to an Omcan Service warehouse to repair the equipment.

Unauthorized maintenance will void the warranty. Warranty covers electrical and part failures, not improper use.

Please see [www.omcan.com/warranty.html](http://www.omcan.com/warranty.html) for complete info.

**WARNING:**

The packaging components are classified as normal solid urban waste and can therefore be disposed of without difficulty.

In any case, for suitable recycling, we suggest disposing of the products separately (differentiated waste) according to the current norms.

**DO NOT DISCARD ANY PACKAGING MATERIALS IN THE ENVIRONMENT!**

# Technical Specifications

---

<b>Model</b>	<b>PG-CN-0711-RT</b>
<b>Grill Surface</b>	10" x 18" / 254 x 457mm
<b>Power</b>	3200W
<b>Thermostat Control</b>	60 - 300°C / 140 - 572°F
<b>Electrical</b>	220V / 60Hz / 1
<b>Top Grill</b>	Ribbed
<b>Bottom Grill</b>	Ribbed
<b>Weight</b>	73 lbs. / 33.1 kgs.
<b>Dimensions</b>	22" x 15.4" x 9.4" (Close) / 22" x 15.4" x 22.25" (Open) 557 x 390 x 238mm (Close) / 557 x 390 x 572mm (Open)
<b>Item Number</b>	42914

## Installation

---

The griddle should be placed on a solid leveled surface. If the unit is placed in close proximity to a wall, partitions, kitchen furniture, decorative finish, etc. it is recommended that they be made of non-combustible material. If not, they should be clad with a suitable non-combustible heat-insulating material and fire prevention regulations should be enforced.

**Make sure to perform a thorough cleaning of the grill before first operation to ensure that no residual chemicals are present when cooking.**

## Operation

---

Always preheat the grill before use until the ready light illuminates. Lift the top grill plate, arrange food on the bottom plate and bring top plate back down to make contact with food and begin cooking. If additional sandwiches are desired, lower the lid to preserve the heat while you prepare the additional sandwiches. When not cooking, the thermostat is turned off, switch off the on/off switch, unplug the unit

If the Omcan Grill does not work, please check the following:

1. The power supply is correct and switched on.
2. The positions of switch and thermostat are correct.

### RE-PROGRAMMABLE TIMER INSTRUCTIONS

**Note: Be sure the unit is unplugged and cool prior to installing or removing the re-programmable timer.**

# Operation

---

## 1. Installing the batteries

- Place your fingers on the two tabs on the sides of the timer and firmly depress and pulling towards you, the timer is released from the unit, then open battery box cover, install batteries in, then slide battery cover back into the position.
- Check timer to ensure power is supplied by pressing “-”.
- Insert timer into the port until side tabs lock into place.

## 2. Programming the timer

**Note: The timer will not automatically shut off your unit. Once your programmed time has lapsed, the unit will beep 5 times and the screen will go blank.**

### Program manually

To manually program the timer, hold both “-” and “+” at the same time for four seconds. The timer will beep twice. After the second beep, use the “-” and “+” to scroll to your desired time setting up to 19:59.

For fast scroll, hold the button down until you have reached your desired time setting. The timer will automatically program the setting after five seconds. Now that you have programmed your time, you may press the “-” button any time to start the timer. Once programmed, the timer will always default to the time setting until otherwise changed.

### Program using count-up mode

Your re-programmable timer allows you to program your time using count-up mode. This is convenient for when you need to first measure the time required to grill your sandwich before programming. Once you have started grilling, press the “+” button to start the timer. When you have finished grilling, press both “-” and “+” to set the time. Once programmed, the timer will always default to this time setting until otherwise changed.

**Note: When batteries are removed, the timer automatically defaults to the factory setting of 10 seconds.**

# Maintenance

---

Once the griddle is placed in a position by consulting International Standards and regulations. Cleaning the cast iron plate is thoroughly advised.

Warm up the cast iron plate for 10 minutes until all smoke and/or odor has dissipated.

Switch off and unplug the unit, then use warm, soapy water to clean, followed by a rinse with warm water. Be sure to always wash the grill plates after each use to remove any residue that may have accumulated.

For cleaning cast iron plate, please use warm soapy water while still warm. Do not use cold water on hot plate.

After cleaning, be sure the oil tray must be dry thoroughly before putting it back to the unit. Do not immerse completely in water or any liquid to clean and the appliance should not be cleaned with a water jet.

# Maintenance

---

NEVER USE COLD WATER ON THE HOT PLATE.

## REFERENCE

Item Number	Model Number	Description	Manufacturer Model Number
42914	PG-CN-0711-RT	Panini Grill 10" x 18" / 254mm x 457mm Double Rib/Rib with Timer 220V/60/1 cETLus	PA10176T

# Parts Breakdown

---

## Model PG-CN-0711-RT 42914

Item No.	Description	Position	Item No.	Description	Position	Item No.	Description	Position
20337	Big Handle for PA10176T	1	<a href="#">20344</a>	Thermo Cut Out for PA10176T	8	<a href="#">20349</a>	Indicator Light for PA10176T	15
20338	Small Handle for PA10176T	2	20345	Plug and Lead for PA10176T	9	20350	Oil Tray for PA10176T	16
20339	Top Element for PA10176T	3	72220	Handle for PA10176T	10	72221	Timer for PA10176T	17
72215	Top Cast Iron for PA10176T	4	72217	Bottom for PA10176T	11	<a href="#">20351</a>	On / Off Switch for PA10176T	18
72216	Bottom Cast Iron for PA10176T	5	20346	Foot for PA10176T	12	26023	Double Panini Top Cover for PA10176T	19
<a href="#">20342</a>	Bottom Element for PA10176T	6	<a href="#">20347</a>	Thermostat for PA10176T	13			
20343	Body for PA10176T	7	<a href="#">20348</a>	Dial for PA10176T	14			

# Parts Breakdown

Model PG-CN-0711-RT 42914

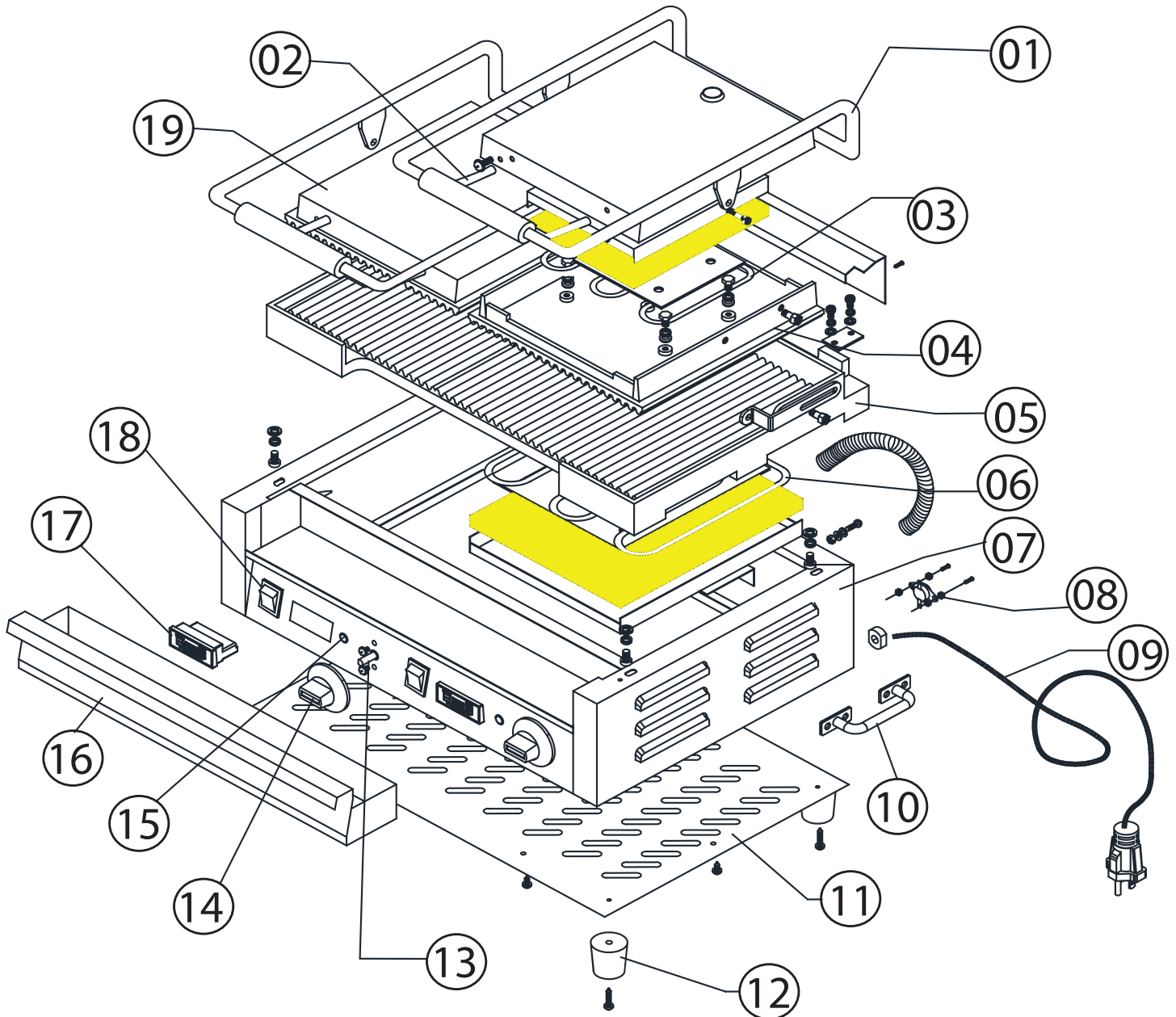

# Electrical Schematics

Model PG-CN-0711-RT 42914

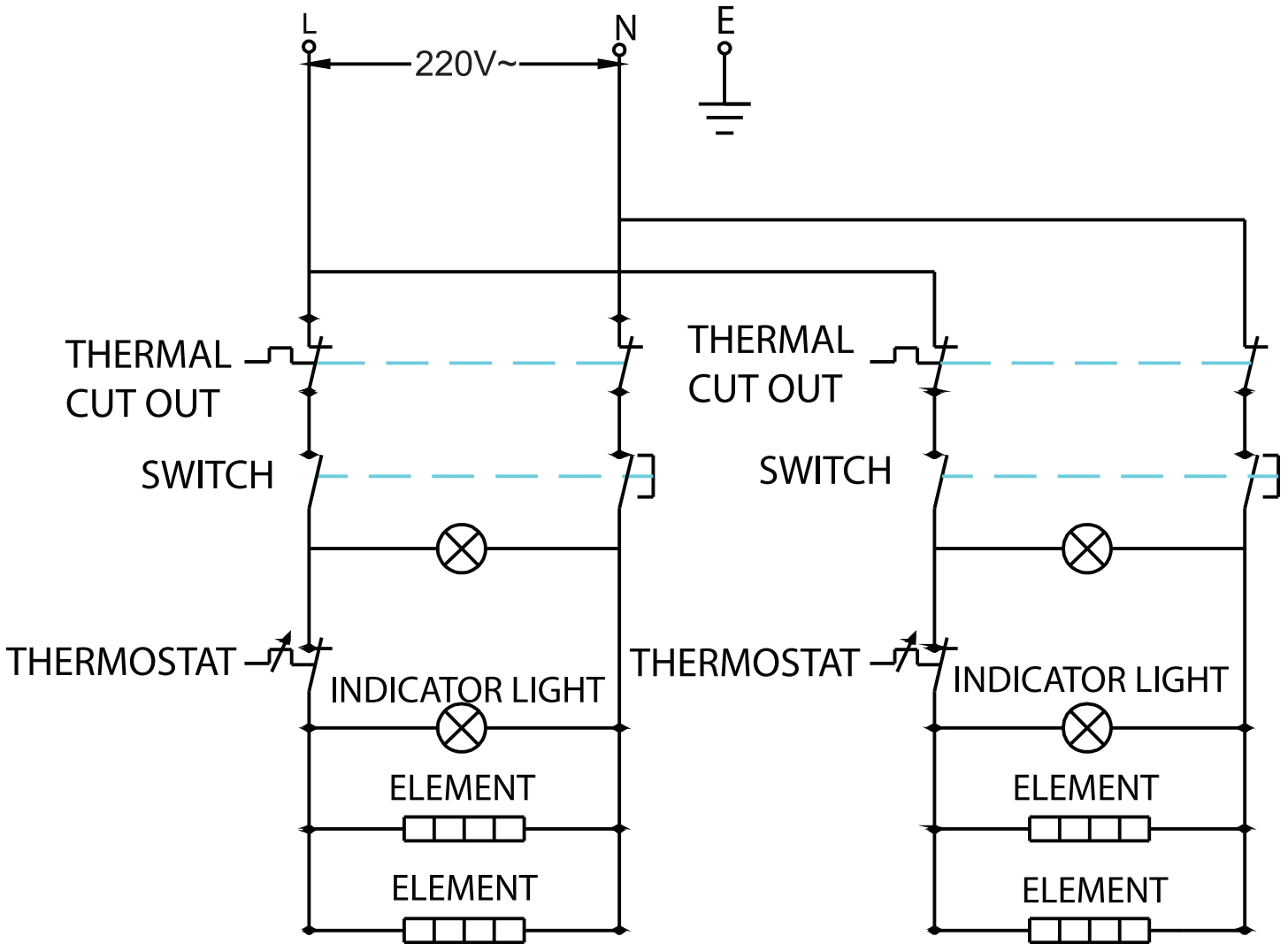



# Warranty Registration

Thank you for purchasing an Omcan product. To register your warranty for this product, complete the information below, tear off the card at the perforation and then send to the address specified below. You can also register online by visiting:

Merci d'avoir acheté un produit Omcan. Pour enregistrer votre garantie pour ce produit, complétez les informations ci-dessous, détachez la carte au niveau de la perforation, puis l'envoyer à l'adresse spécifiée ci-dessous. Vous pouvez également vous inscrire en ligne en visitant:

Gracias por comprar un producto Omcan usted. Para registrar su garantía para este producto, complete la información a continuación, cortar la tarjeta en la perforación y luego enviarlo a la dirección indicada a continuación. También puede registrarse en línea en:

[www.omcan.com/warrantyregistration.html](http://www.omcan.com/warrantyregistration.html)

For mailing in Canada

Pour postale au Canada

Por correo en Canadá

**OMCAN**

PRODUCT WARRANTY REGISTRATION

3115 Pepper Mill Court,

Mississauga, Ontario

Canada, L5L 4X5

For mailing in the US

Pour diffusion aux États-Unis

Por correo en los EE.UU.

**OMCAN**

PRODUCT WARRANTY REGISTRATION

4450 Witmer Industrial Estates, Unit 4,

Niagara Falls, New York

USA, 14305

*or email to: [service@omcan.com](mailto:service@omcan.com)*



Purchaser's Information

Name: \_\_\_\_\_

Address: \_\_\_\_\_

City: \_\_\_\_\_ Province or State: \_\_\_\_\_ Postal or Zip: \_\_\_\_\_

Country: \_\_\_\_\_

Dealer from which Purchased: \_\_\_\_\_

Dealer City: \_\_\_\_\_ Dealer Province or State: \_\_\_\_\_

Invoice: \_\_\_\_\_

Model Name: \_\_\_\_\_ Model Number: \_\_\_\_\_

Machine Description: \_\_\_\_\_

Date of Purchase (MM/DD/YYYY): \_\_\_\_\_

Would you like to extend the warranty?  Yes  No

Company Name: \_\_\_\_\_

Telephone: \_\_\_\_\_

Email Address: \_\_\_\_\_

Type of Company:

Restaurant  Bakery  Deli

Butcher  Supermarket  Caterer

Institution (*specify*): \_\_\_\_\_

Other (*specify*): \_\_\_\_\_

Serial Number: \_\_\_\_\_

Date of Installation (MM/DD/YYYY): \_\_\_\_\_

**Thank you for choosing Omcan | Merci d'avoir choisi Omcan | Gracias por elegir Omcan**



Since 1951 Omcan has grown to become a leading distributor of equipment and supplies to the North American food service industry. Our success over these many years can be attributed to our commitment to strengthen and develop new and existing relationships with our valued customers and manufacturers. Today with partners in North America, Europe, Asia and South America, we continually work to improve and grow the company. We strive to offer customers exceptional value through our qualified local sales and service representatives who provide convenient access to over 3, 500 globally sourced products.

---

Depuis 1951 Omcan a grandi pour devenir un des “leaders” de la distribution des équipements et matériel pour l’industrie des services alimentaires en Amérique du Nord. Notre succès au cours de ces nombreuses années peut être attribué à notre engagement à renforcer et à développer de nouvelles et existantes relations avec nos clients et les fabricants de valeur. Aujourd’hui avec des partenaires en Amérique du Nord, Europe, Asie et Amérique du Sud, nous travaillons continuellement à améliorer et développer l’entreprise. Nous nous efforçons d’offrir à nos clients une valeur exceptionnelle grâce à nos ventes locales qualifiées et des représentants de service qui offrent un accès facile à plus de 3500 produits provenant du monde entier.

---

Desde 1951 Omcan ha crecido hasta convertirse en un líder en la distribución de equipos y suministros de alimentos en América del Norte industria de servicios. Nuestro éxito en estos años se puede atribuir a nuestro compromiso de fortalecer y desarrollar nuevas relaciones existentes con nuestros valiosos clientes y fabricantes. Hoy con socios de América del Norte, Europa, Asia y América del Sur, que trabajan continuamente para mejorar y crecer la empresa. Nos esforzamos por ofrecer a nuestros clientes valor excepcional a través de nuestro local de ventas y representantes de los servicios que proporcionan un fácil acceso a más de 3, 500 productos con origen a nivel mundial.

