



Sandwich Grills

Models PG-IT-0483-R, 0483, 0610-R, 0737-R, 0737

Items 11375, 11376, 11377, 11378, 11380

Instruction Manual



Revised - 09/01/2017



Toll Free: 1-800-465-0234
Fax: 905-607-0234
Email: service@omcan.com
www.omcan.com

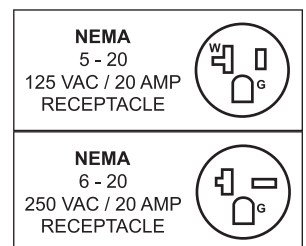

Table of Contents

Model PG-IT-0483-R / Model PG-IT-0483 / Model PG-IT-0610-R
Model PG-IT-0737-R / Model PG-IT-0737

Section	Page
General Information -----	3 - 4
Safety and Warranty -----	4 - 5
Technical Specifications -----	6
Installation -----	6 - 7
Operation -----	8 - 9
Maintenance -----	9 - 10
Parts Breakdown -----	11 - 18
Electrical Schematics -----	19 - 20
Notes -----	21 - 22
Warranty Registration -----	23



General Information

Omcan Manufacturing and Distributing Company Inc., Food Machinery of America, Inc. dba Omcan and Omcan Inc. are not responsible for any harm or injury caused due to any person's improper or negligent use of this equipment. The product shall only be operated by someone over the age of 18, of sound mind, and not under the influence of any drugs or alcohol, who has been trained in the correct operation of this machine, and is wearing authorized, proper safety clothing. Any modification to the machine voids any warranty, and may cause harm to individuals using the machine or in the vicinity of the machine while in operation.

CHECK PACKAGE UPON ARRIVAL

Upon receipt of an Omcan shipment please inspect for external damage. If no damage is evident on the external packaging, open carton to ensure all ordered items are within the box, and there is no concealed damage to the machine. If the package has suffered rough handling, bumps or damage (visible or concealed), please note it on the bill of lading before accepting the delivery and contact Omcan within 24 hours, so we may initiate a claim with the carrier. A detailed report on the extent of the damage caused to the machine must be filled out within three days, from the delivery date shown in the shipping documents. Omcan has no recourse for damaged products that were shipped collect or third party.

Before operating any equipment, always read and familiarize yourself with all operation and safety instructions.

Omcan would like to thank you for purchasing this machine. It's of the utmost importance to save these instructions for future reference. Also save the original box and packaging for shipping the equipment if servicing or returning of the machine is required.

Omcan Fabrication et distribution Compagnie Limitée et Food Machinery d'Amérique, dba Omcan et Omcan Inc. ne sont pas responsables de tout dommage ou blessure causé du fait que toute personne ait utilisé cet équipement de façon irrégulière. Le produit ne doit être exploité que par quelqu'un de plus de 18 ans, sain d'esprit, et pas sous l'influence d'une drogue ou d'alcool, qui a été formé pour utiliser cette machine correctement, et est vêtu de vêtements de sécurité appropriés. Toute modification de la machine annule toute garantie, et peut causer un préjudice à des personnes utilisant la machine ou des personnes à proximité de la machine pendant son fonctionnement.

VÉRIFIEZ LE COLIS DÈS RÉCEPTION

Dès réception d'une expédition d'Omcan veuillez inspecter pour dommages externes. Si aucun dommage n'est visible sur l'emballage externe, ouvrez le carton afin de s'assurer que tous les éléments commandés sont dans la boîte, et il n'y a aucun dommage dissimulé à la machine. Si le colis n'a subi aucune mauvaises manipulations, de bosses ou de dommages (visible ou cachée), notez-le sur le bond de livraison avant d'accepter la livraison et contactez Omcan dans les 24 heures qui suivent, pour que nous puissions engager une réclamation auprès du transporteur. Un rapport détaillé sur l'étendue des dommages causés à la machine doit être rempli dans un délai de trois jours, à compter de la date de livraison indiquée dans les documents d'expédition. Omcan n'a aucun droit de recours pour les produits endommagés qui ont été expédiés ou cueilli par un tiers transporteur.

General Information

Avant d'utiliser n'importe quel équipement, toujours lire et vous familiariser avec toutes les opérations et les consignes de sécurité.

Omcan voudrais vous remercier d'avoir choisi cette machine. Il est primordial de conserver ces instructions pour une référence ultérieure. Également conservez la boîte originale et l'emballage pour l'expédition de l'équipement si l'entretien ou le retour de la machine est nécessaire.

Omcan Empresa De Fabricacion Y Distribucion Inc. Y Maquinaria De Alimentos De America, Inc. dba Omcan y Omcan Inc. no son responsables de ningun daño o perjuicio causado por cualquier persona inadecuada o el uso descuidado de este equipo. El producto solo podra ser operado por una persona mayor de 18 años, en su sano juicio y no bajo alguna influencia de droga o alcohol, y que este ha sido entrenado en el correcto funcionamiento de esta máquina, y ésta usando ropa apropiada y autorizada. Cualquier modificación a la máquina anula la garantía y puede causar daños a las personas usando la máquina mientras esta en el funcionamiento.

REVISE EL PAQUETE A SU LLEGADA

Tras la recepcion de un envio Omcan favor inspeccionar daños externos. Si no hay daños evidentes en el empaque exterior, Habra el carton para asegurarse que todos los articulos solicitados estén dentro de la caja y no encuentre daños ocultos en la máquina. Si el paquete ha sufrido un manejo de poco cuidado, golpes o daños (visible o oculto) por favor anote en la factura antes de aceptar la entrega y contacte Omcan dentro de las 24 horas, de modo que podamos iniciar una reclamación con la compañía. Un informe detallado sobre los daños causados a la máquina debe ser llenado en el plazo de tres días, desde la fecha de entrega que se muestra en los documentos de envío. Omcan no tiene ningun recurso por productos dañados que se enviaron a recoger por terceros.

Antes de utilizar cualquier equipo, siempre lea y familiarizarse con todas las instrucciones de funcionamiento y seguridad.

Omcan le gustaría darle las gracias por la compra de esta máquina. Es de la mayor importancia para salvar estas instrucciones para futuras consultas. Además, guarda la caja original y el embalaje para el envío del equipo si servicio técnico o devolución de la máquina que se requiere.

Safety and Warranty

GENERAL PRECAUTIONS

- The machine must be operated only by highly trained personnel who are fully aware of the safety measures described in this manual.
- In case of a change in operator, training is to be provided in advance.
- Before starting cleaning and maintenance operations, turn off and disconnect the plug from the socket.
- Cleaning and maintenance requires great concentration.

Safety and Warranty

- A regular check of the electric supply cord is necessary; a worn-out or damage cord should not be used.
- If the machine has malfunctions, do not use it and do not repair it; please call the Omcan Service Center at 1-800-465-0234.
- The grill is used for cooking, heating, toasting, and to grill foodstuffs. Do not use the machine for other uses or for any products other than foodstuffs.

The manufacturer is not liable in the following cases:

1. If the machine has been tampered or adjusted by non-authorized personnel;
2. If some parts have been substituted with non original spare parts;
3. If the instructions contained in this manual are not followed;
4. If the machine surface is not cleaned with the right product.

SAFETY DEVICES

The electrical safety devices installed on the machine, described in this manual, complies with EC 73/23, 89/336, 89/109. Even though the griller is provided with electrical and mechanical protections when the machine is working and for maintenance and cleaning operations, there are still risks that cannot be eliminated completely. These risks are scalds caused by the loading and unloading of the product, or other kind of injuries due to the maintenance operations.

The unit complies with:

- UL 197, 8° edition
- NSF 4, 1991 edition

1 YEAR PARTS AND LABOUR BENCH WARRANTY

Within the warranty period, contact Omcan Inc. at 1-800-465-0234 to schedule a drop off to either an Omcan authorized service depot in the area, or to an Omcan Service warehouse to repair the equipment.

Unauthorized maintenance will void the warranty. Warranty covers electrical and part failures, not improper use.

Please see www.omcan.com/warranty.html for complete info.

WARNING:

The packaging components are classified as normal solid urban waste and can therefore be disposed of without difficulty.

In any case, for suitable recycling, we suggest disposing of the products separately (differentiated waste) according to the current norms.

DO NOT DISCARD ANY PACKAGING MATERIALS IN THE ENVIRONMENT!

Technical Specifications

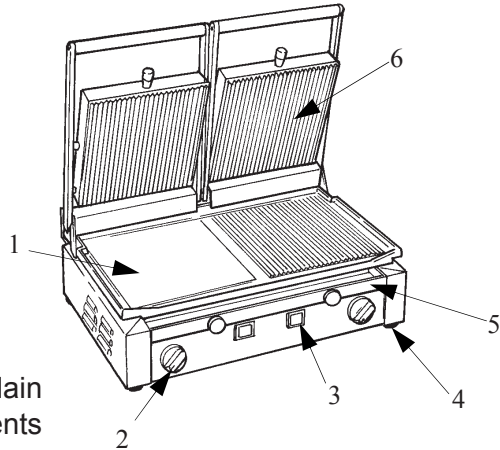

Fig. 1: Main components

MAIN COMPONENTS

1. Lower Cooking Grill
2. Thermostat
3. Pilot Lamp
4. Feet
5. Collection Tray
6. Upper Cooking Grill

Model	PG-IT-0483-R	PG-IT-0483	PG-IT-0610-R	PG-IT-0737-R	PG-IT-0737
Grill Surface	10" x 9" 254 x 229mm		10" x 14" 254 x 356mm	10" x 19" 254 x 483mm	
Power	1700W			3000W	
Amps	15			13.5	
Thermostat Control	50 - 300°C / 120 - 570°F				
Electric	110V / 60Hz / 1			220V / 60Hz / 1	
Top Grill	Ribbed				
Bottom Grill	Ribbed	Smooth	Ribbed		1/2 Smooth 1/2 Ribbed
Weight	40 lbs. 18 kgs.	35 lbs. 16 kgs.	53 lbs. 24 kgs.	56 lbs. 25 kgs.	70 lbs. 31.75 kgs.
Item Number	11375	11376	11377	11378	11380

WARNING: The electrical characteristics for which the appliance is designed are indicated on the reference plate applied on the side of the machine; check to make sure it corresponds with the electrical supply before connecting.

Installation

ASSEMBLY

The package of the grillers includes (see Fig. 2):

- a. Cardboard box and internal protections;
- b. The machine;
- c. This manual;

- d. Scraper or brush (f) in accordance with the model;
- e. EC conformity declaration.

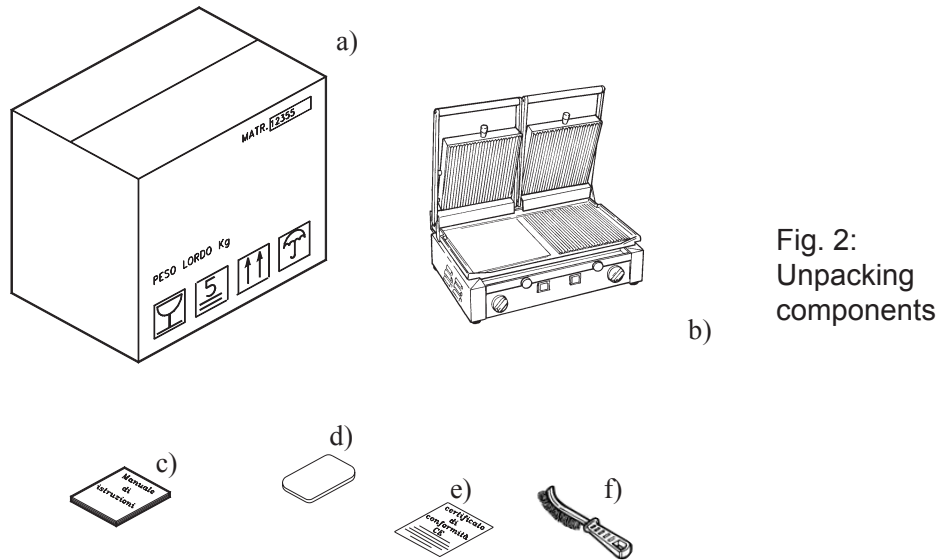

Fig. 2:
Unpacking
components

PACKAGING DISPOSAL

The components of the packaging are urban solid waste; therefore they can be easily disposed. If the machine has to be installed in countries where specific regulations are in force, packaging must be disposed in compliance with them.

SETTING UP OF THE MACHINE

The machine must be installed on a work table suitable for the grills overall dimensions as shown. It must be adequately large, level, dry, smooth, resistant, stable and at a height of 80 cm from the ground. The machine must be installed in a room with a maximum of 75% humidity and a temperature between +5°C and +35°C.

ELECTRICAL CONNECTIONS

The machine is equipped with a power supply cord. To connect the machine, follow the indication of the rating plate. Check that unit is grounded. Check that the features on the rating plate correspond to the features shown in the consignment and delivery note, and that the disconnecting plug and the socket are easy to reach when the machine is functioning.

Operation

To check the machine functioning, just turn the “start” regulator knob clockwise (placing yourself in front of the knob), and starting from the minimum, observe if the pilot lamp turns on. When the pilot lamp is on, it means that the machine is functioning.

1. Thermostat.
2. Pilot Lamp, it indicates that the grill is on.

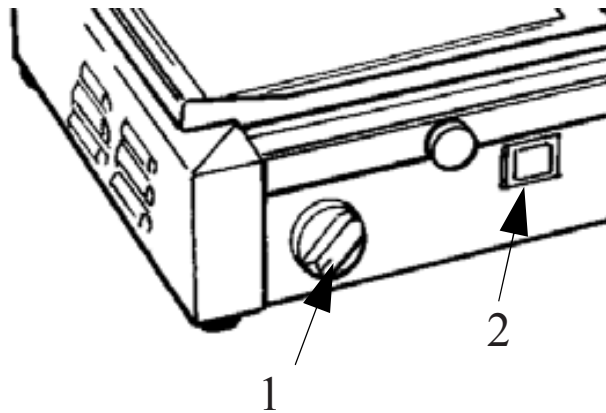

Fig. 3:
Control
switches
positioning.

FIRST USE OF THE MACHINE

When the machine is delivered, the steel surfaces are protected with a nylon anti-scratch film and residuals of glue. This film and glue has to be removed before starting the machine. Do not use sharpening tools, flammable or abrasive substances. The insulating materials used during the manufacturing and the residuals of grease and glue may produce smoke during first operation. It is necessary to start the machine outdoors, for a minimum of 15-20 minutes before normal use.

WARNING: When you place the product on the grid to cook, it will be hot. Pay attention to cooking operations to avoid burning dangers.

To load the product follow this procedure:

1. Place yourself in a correct position (see Figure 4), avoiding any contact with the machine;
2. Choose the correct temperature using the knob;
3. When the griller is hot, place the product and start the cooking;
4. At the end of the cooking, remove the food and residuals from the grill;
5. If the griller is inactive for a long period (one or two hours), place the knob to 0°C and unplug.

If the machine has been turned off longer than 30 min., allow at least 10 min. for it to reach cooking temperature again. If you are not using the machine, but you think you are going to need it soon, set the temperature at 120 F, this will allow the machine to reach cooking temperature faster.

Operation

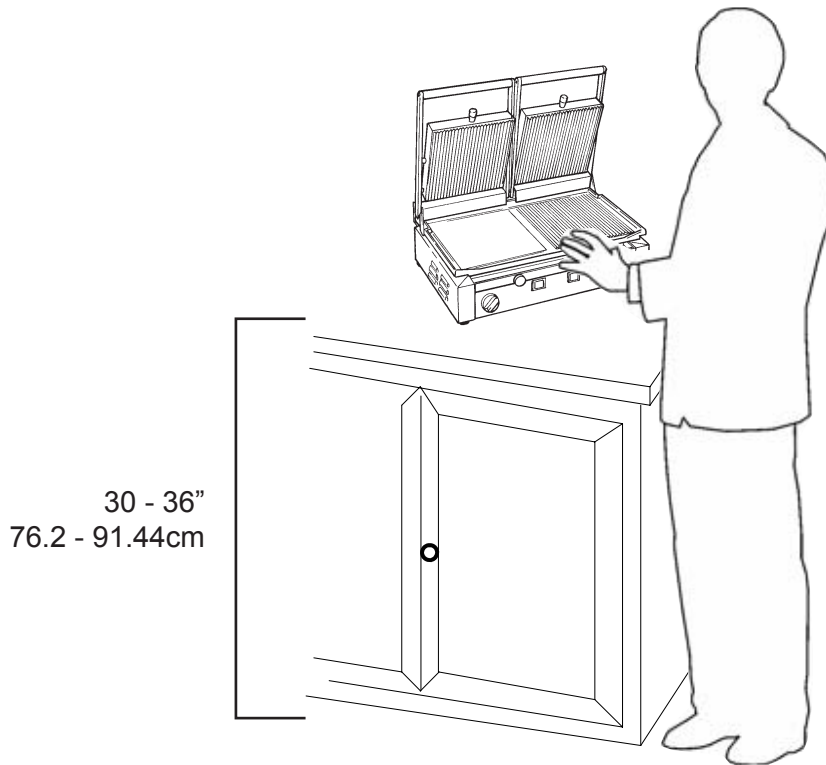

Fig. 4: Proper operation position.

Maintenance

- Cleaning the machine should be performed at least once a day and, if necessary more often.
- Never clean the machine by means of water jets, or submerge the machine.
- The cleaning of the grill can be performed when it is hot, scrape with a metallic brush on the cooking grid several times.

ATTENTION: Do not to touch the cooking surface because this could cause burns.

- Use the same care when emptying the collecting tray to make gravy.
- It is recommended to perform these cleaning operations when the temperature has dropped but the residual grease which sticks to the grill is still a liquid.
- Do not pour water or other liquids on the grid when it is hot, because the rapid changes of temperature can damage the grills surface.

WARNING: Before performing any cleaning operation, turn off and disconnect the plug from the electrical socket.

Periodically check whether the power cord is worn-out and, if this is the case, please call the Omcan Service

Maintenance

Center at 1-800-465-0234 to have it replaced.

DISPOSAL OF THE MACHINE

If you decide to put the machine out of service, disconnect it from the socket. To dismantle the machine contact a Specialized Disposal Centre, paying attention to the different materials used.

REFERENCE

Item Number	Model Number	Description	Manufacturer Model Number
11375	PG-IT-0483-R	Panini Grill 10" x 9" / 254mm x 229mm Single Rib/Rib 110V/60/1 ETL cETLus	SG101
11376	PG-IT-0483	Panini Grill 10" x 9" / 254mm x 229mm Single Rib/Smooth 110V/60/1 ETL cETLus	SG101FBR
11377	PG-IT-0610-R	Panini Grill 10" x 14" / 254mm x 356mm Single Rib/Rib 110V/60/1 ETL cETLus	SG301
11378	PG-IT-0737-R	Panini Grill 10" x 19" / 254mm x 483mm Double Rib/Rib 220V/60/1 ETL cETLus	SG501
11380	PG-IT-0737	Panini Grill 10" x 19" / 254mm x 483mm Double Rib/Smooth 220V/60/1 ETL cETLus	SG501FBR

Parts Breakdown

Model PG-IT-0483-R 11375

Model PG-IT-0483 11376

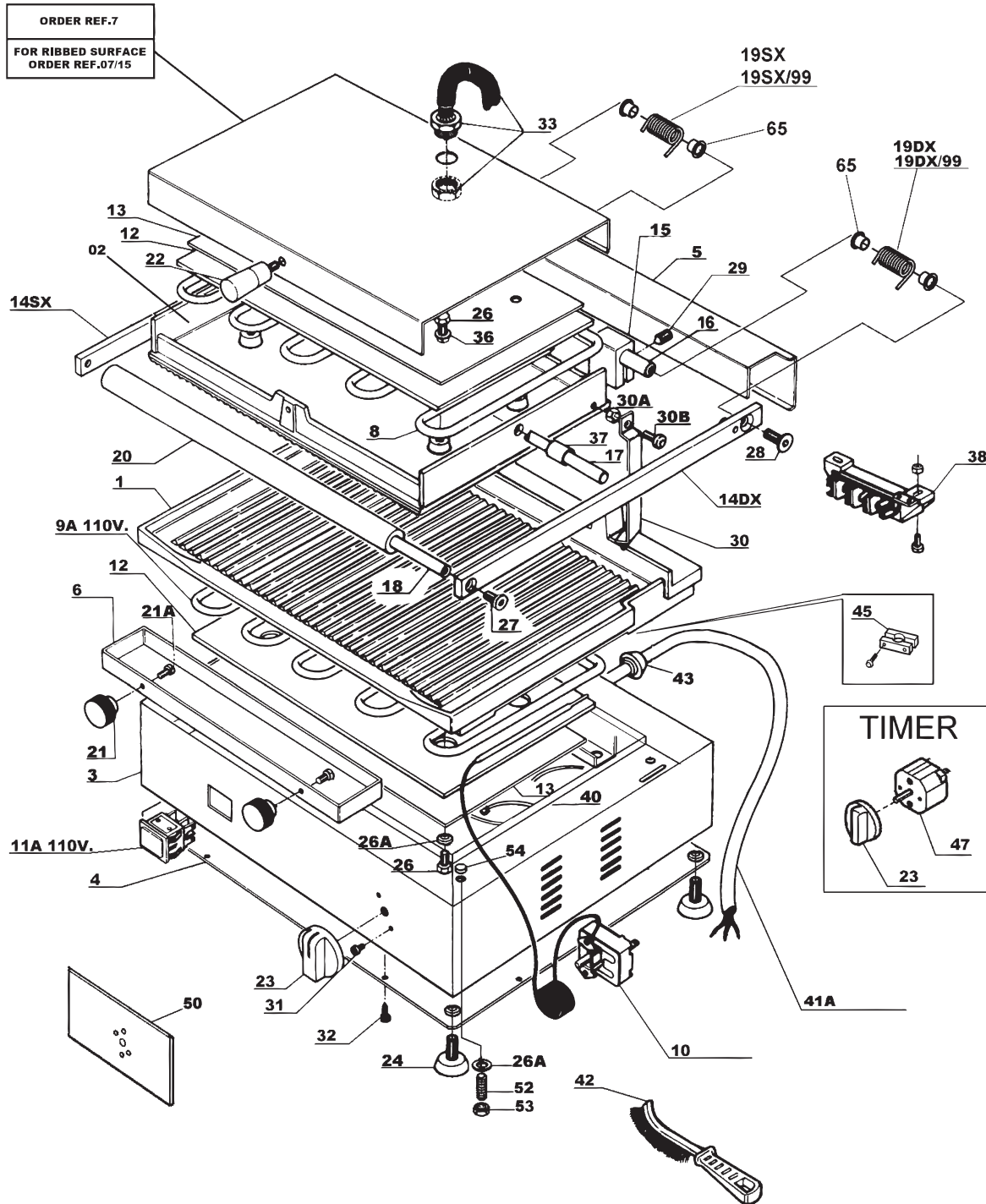

Parts Breakdown

Model PG-IT-0483-R 11375

Item No.	Description	Position	Item No.	Description	Position	Item No.	Description	Position
37262	Bottom Plate - Ribbed USA for SG101	1	37279	Lift Arm Right from 99 for SG101	14DX	37272	Top Plate Guide for SG101	30
78744	Bottom Surface-Grooved for Grill for SG101	1	78749	Right Lifting Rod until 99 for SG101	14DX	16480	Protection Spiral for SG101	33
37263	Top Plate - Ribbed USA for SG101	2	37296	Lift Arm Left from 99 for SG101	14SX	23750	Upper Wiring for SG101	34
78746	Top Surface-Grooved for Grill for SG101	2	78750	Left Lifting Rod until 99 for SG101	14SX	78756	Top Wiring for SG101	34
78747	Upper Plate Ribbed USA for SG101	2	37270	Brass Brake for SG101	15	37273	Washer Dia.6 for SG101	36
37285	Stainless Steel Base for SG101	3	23746	Lifting Pin 12mm for SG101	16	19369	Spacer Ring for SG101	37A
78768	Base INOX LEI L/R ECO for SG101	3	37291	Balance Pin for SG101	17	19368	Spacer Ring-External for SG101	37B
37265	Bottom Enclosure Panel for SG101	4	19365	Handle Pin for SG101	18	19372	Terminal Block for SG101	38
78769	COP. INF. Galvanized LEI L/R ECO for SG101	4	16476	Right Spring from 99 for SG101	19DX	37275	Bottom Wiring for SG101	40
78748	Hinge Cover for SG101	5	78751	Right Spring before 99 for SG101	19DX	37283	Power Cord 115V 15A USA for SG101	41A
18680	Stainless Steel Drip Tray for SG101	6	16478	Left Spring from 99 for SG101	19SX	37276	Brush for Grill for SG101	42
78770	Box RACC. INOX LEI L/R ECO for SG101	6	19370	Lifting Handle for SG101	20	78762	Strain Relief for SG101	43
19366	Top Surface Cover for SG101	7	19371	Drip Tray Knob for SG101	21A	37277	Strain Relief PA268 USA for SG101	45
16470	Upper/Top Element 110V for SG101	8A	78752	Knob CASS. Red for SG101	21B	78763	Timer for SG101	47
18828	Bottom Heating Element 110V for SG101	9A	78753	Upper Knob Black for SG101	22A	37278	Face Plate for SG101	50
16474	Thermostat 110/220-50/60 for SG101	10	37282	Upper Knob for SG101	22B	78764	MOSTR. PERS/Neutral for SG101	50A
23747	Pilot Light 110V for SG101	11A	78755	Knob - Thermostat/Timer for SG101	23A	78766	Face Plate for SG101	51
21103	Insulating Panel 110 ZK for SG101	12	78754	Knob Red Color, Thermostat for SG101	23B	78765	MOSTR. PERS/Neutral Timer for SG101	51A
37286	Cover Insulation Panel for SG101	13	18681	Foot for SG101	24	78767	Bushing Flange D.12 for SG101	65

Parts Breakdown

Model PG-IT-0483 11376

Item No.	Description	Position	Item No.	Description	Position	Item No.	Description	Position
37284	Bottom Plate - Flat USA for SG101FBR	1	37279	Lift Arm Right from 99 for SG101FBR	14DX	37272	Top Plate Guide for SG101FBR	30
78743	Bottom Surface-Flat for Grill for SG101FBR	1	78749	Right Lifting Rod until 99 for SG101FBR	14DX	16480	Protection Spiral for SG101FBR	33
37263	Top Plate - Ribbed USA for SG101FBR	2	37296	Lift Arm Left from 99 for SG101FBR	14SX	23750	Upper Wiring for SG101FBR	34
78746	Top Surface-Grooved for Grill for SG101FBR	2	78750	Left Lifting Rod until 99 for SG101FBR	14SX	78756	Top Wiring for SG101FBR	34
78747	Upper Plate Ribbed USA for SG101FBR	2	37270	Brass Brake for SG101FBR	15	37273	Washer Dia.6 for SG101FBR	36
37285	Stainless Steel Base for SG101FBR	3	23746	Lifting Pin 12mm for SG101FBR	16	19369	Spacer Ring for SG101FBR	37A
78768	Base INOX LEI L/R ECO for SG101FBR	3	37291	Balance Pin for SG101FBR	17	19368	Spacer Ring-External for SG101FBR	37B
37265	Bottom Enclosure Panel for SG101FBR	4	19365	Handle Pin for SG101FBR	18	19372	Terminal Block for SG101FBR	38
78769	COP. INF. Galvanized LEI L/R ECO for SG101FBR	4	16476	Right Spring from 99 for SG101FBR	19DX	37275	Bottom Wiring for SG101FBR	40
78748	Hinge Cover for Grill for SG101FBR	5	78751	Right Spring before 99 for SG101FBR	19DX	37283	Power Cord 115V 15A USA for SG101FBR	41A
18680	Stainless Steel Drip Tray for SG101FBR	6	16478	Left Spring from 99 for SG101FBR	19SX	37276	Brush for SG101FBR	42
78770	Box RACC. INOX LEI L/R ECO for SG101FBR	6	19370	Lifting Handle for SG101FBR	20	78762	Strain Relief for SG101FBR	43
19366	Top Surface Cover for SG101FBR	7	19371	Drip Tray Knob for SG101FBR	21A	37277	Strain Relief PA268 USA for SG101FBR	45
16470	Upper/Top Element 110V for SG101FBR	8A	78752	Knob CASS.Red for SG101FBR	21B	78763	Timer for SG101FBR	47
18828	Bottom Heating Element 110V for SG101FBR	9A	78753	Upper Knob Black for SG101FBR	22A	37278	Face Plate for SG101FBR	50
16474	Thermostat 110/220-50/60 for SG101FBR	10	37282	Upper Knob for SG101FBR	22B	78764	MOSTR. PERS/Neutral LEI for SG101FBR	50A
23747	Pilot Light 110V for SG101FBR	11A	78755	Knob - Thermostat/Timer for SG101FBR	23A	78766	Face Plate for SG101FBR	51
21103	Insulating Panel 110 ZK for SG101FBR	12	78754	Knob Red Color, Thermostat for SG101FBR	23B	78765	MOSTR. PERS/Neutral Timer LEI for SG101FBR	51A
37286	Cover Insulation Panel for SG101FBR	13	18681	Foot for SG101FBR	24	78767	Bushing Flange D.12 for SG101FBR	65

Parts Breakdown

Model PG-IT-0610-R 11377

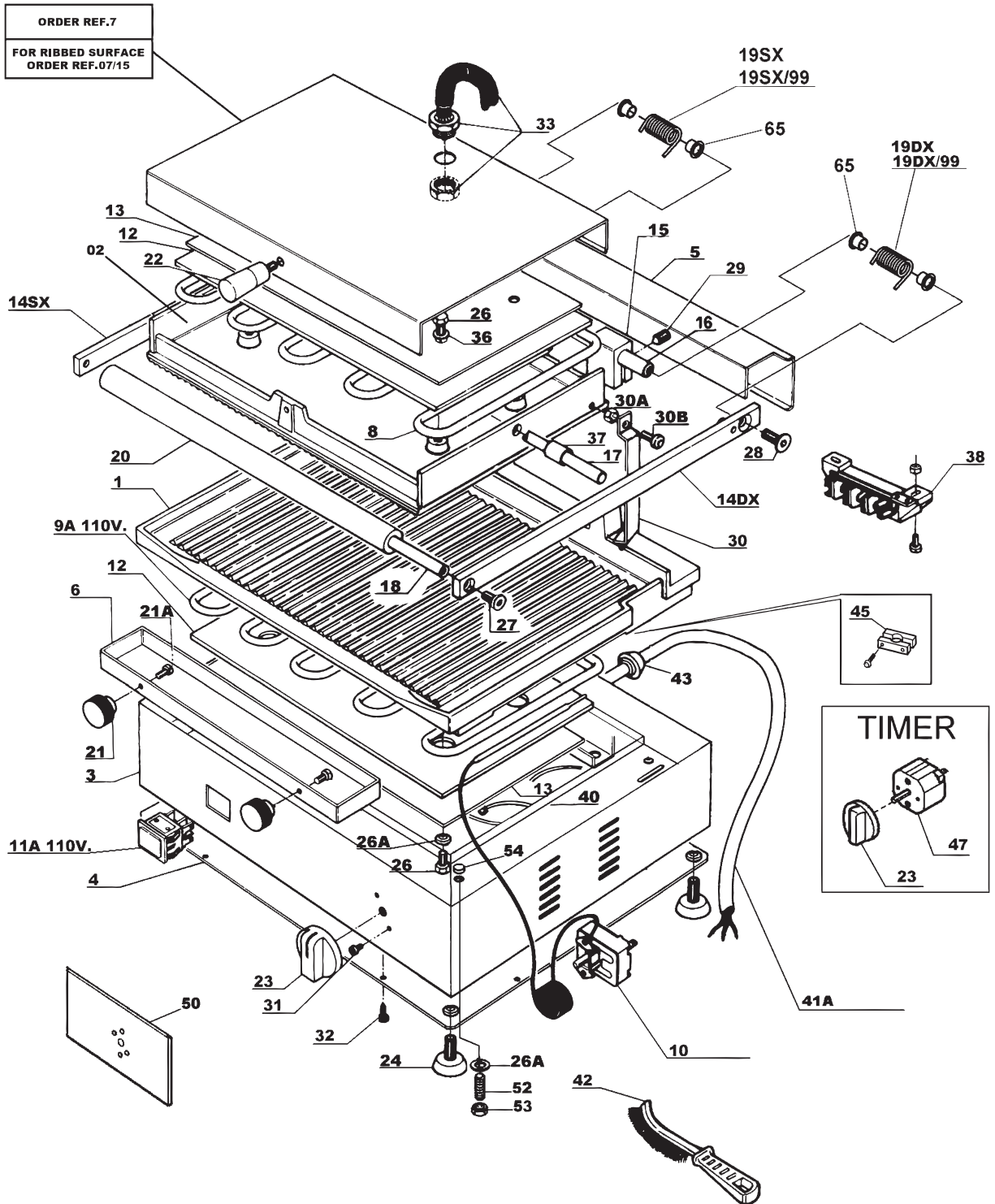

Parts Breakdown

Model PG-IT-0610-R 11377

Item No.	Description	Position	Item No.	Description	Position	Item No.	Description	Position
37288	Bottom Plate - Ribbed for SG301	1	37279	Lift Arm Right from 99 for SG301	14DX	78788	Anti-Overtum Right ECO for SG301	30
78773	Flat Bottom Plate for SG301	1	78749	Right Lifting Rod for Grill until 99 for SG301	14DX	78800	Bracket for SG301	30
78774	Lower Plate Smooth USA for SG301	1	37296	Lift Arm Left from 99 for SG301	14SX	16480	Protection Spiral for SG301	33
78775	Ribbed Bottom Plate for SG301	1	78750	Left Lifting Rod for Grill until 99 for SG301	14SX	23750	Upper Wiring for SG301	34
37289	Top Plate - Ribbed USA for SG301	2	37270	Brass Brake for SG301	15	78756	Top Wiring for SG301	34
78776	Flat Top Plate for SG301	2	23748	Lifting Pin for SG301	16	37273	Washer Dia.6 for SG301	36
78777	Upper Plate Smooth USA for SG301	2	37292	Balance Pin for SG301	17	37274	Spacer Ring for SG301	37
78778	Top Ribbed Plate for SG301	2	78784	Handle Pin for SG301	18	19372	Terminal Block for SG301	38
78779	Frame INOX for SG301	3	37280	Right Spring from 99 for SG301	19DX	37294	Bottom Wiring for SG301	40
78792	Stainless Steel Base for SG301	3	78785	Right Spring before 99 for SG301	19DX	78789	Bottom Wiring for Grill for SG301	40
78780	COP. INF. Galvanized CRT L/R ECO for SG301	4	37281	Left Spring from 99 for SG301	19SX	37283	Power Cord 115V 15A USA for SG301	41A
78793	Bottom Enclosure Panel for SG301	4	78786	Left Spring before 99 for SG301	19SX	37276	Brush for Grill for SG301	42
78794	Hinge Cover for Grill for SG301	5	37293	Lifting Handle for SG301	20	78762	Strain Relief for SG301	43
78781	Box RACC. INOX CRT L/R ECO for SG301	6	19371	Drip Tray Knob for SG301	21A	37277	Strain Relief USA for SG301	45
78795	Stainless Steel Trash Collecting Bin for SG301	6	78752	Red Knob for SG301	21B	78763	Timer for SG301	47
37267	Top Cover for SG301	7	78787	Black Upper Knob for SG301	22	78790	MOSTR. Graduated Dim. 8x7cm for SG301	50
17757	Top Heating Element 110V for SG301	8A	78797	Top Plate Knob Red for SG301	22B	78804	Face Plate for SG301	50
17758	Bottom Heating Element 110V for SG301	9A	18001	Knob for SG301	23A	78803	Customized Faceplate for SG301	50A
16474	Thermostat 110/220-50/60 for SG301	10	78754	Knob Red Color, Thermostat for SG301	23B	78806	Faceplate with Timer for SG301	51
23747	Pilot Light 110V for SG301	11A	18681	Foot for SG301	24	78805	MOSTR. PERS/Neutral Timer for SG301	51A
37268	Insulating Panel 110 for SG301	12	78798	Screw 6x16 for SG301	27	78791	Spacer Ring for Grill ECO for SG301	54
37269	Insulating Panel Protection for SG301	13	78799	Screw 8x18 for SG301	28			

Parts Breakdown

Model PG-IT-0737-R 11378

Item No.	Description	Position	Item No.	Description	Position	Item No.	Description	Position
37297	Bottom Plate - Ribbed USA for SG501	1	78750	Left Lifting Rod until 99 for SG501	14SX	37311	Left Side Bracket for SG501	30SX
78810	Bottom Ribbed Plate for SG501	1	37270	Brass Brake for SG501	15	16480	Protection Spiral for SG501	33
37307	Top Plate - Ribbed - Right USA for SG501	2DX	23746	Lifting Pin 12mm for SG501	16	37301	Top Wiring for SG501	34
78815	Right Top Surface-Grooved for SG501	2DX	37291	Balance Pin for SG501	17	37302	Upper Wiring for SG501	34
37308	Top Plate - Ribbed - Left USA for SG501	2SX	19365	Handle Pin for SG501	18	37273	Washer Dia.6 for SG501	36
78816	Left Top Surface-Grooved for SG501	2SX	16476	Right Spring from 99 for SG501	19DX	19369	Spacer Ring for SG501	37A
37298	Stainless Steel Base for SG501	3	16475	Right Lifting Spring for SG501	19DX	19368	Spacer Ring-External for SG501	37B
78832	Frame INOX - PD ECO for SG501	3	78817	Right Spring before 99 for SG501	19DX	19372	Terminal Block for SG501	38
37299	Bottom Enclosure Panel for SG501	4	16477	Left Lifting Spring for SG501	19SX	37303	Bottom Wiring for SG501	40
78833	COP. Lower Galvanized TPO-PD R/L/M ECO for SG501	4	16478	Left Spring from 99 for SG501	19SX	78823	Bottom Wiring for SG501	40B
37300	Stainless Steel Rear Cover for SG501	5	19370	Lifting Handle for SG501	20	37283	Power Cord 115V 15A USA for SG501	41
18678	Stainless Steel Drip Tray for SG501	6	78818	Lifting Handle Red for SG501	20B	37276	Brush for SG501	42
19366	Top Surface Cover for SG501	7DX	78819	Lifting Handle Green for SG501	20C	37304	Cable Gland for SG501	43
37309	Upper Left Cover for SG501	7SX	19371	Drip Tray Knob for SG501	21A	37305	Strain Relief USA for SG501	45
16471	Top Heating Element 220V for SG501	8	78752	Knob CASS.Red for SG501	21B	37306	Front Label for SG501	50
16473	Bottom Heating Element 220V for SG501	9	78820	Upper Knob Black for SG501	22A	78790	MOSTR.Graduated 8x7cm for SG501	50
16474	Thermostat 110/220-50/60 for SG501	10	37282	Upper Knob for SG501	22B	78828	Customized Faceplate for SG501	50A
23749	Pilot Light 220V for SG501	11	18001	Knob for SG501	23A	78830	Timer Shield for SG501	51
21103	Insulating Panel 110 ZK for SG501	12	78754	Knob Red Color, Thermostat for SG501	23B	78829	MONST. PERS/Neutral Timer for SG501	51A
20881	Insulating Panel Protection for SG501	13	18681	Foot for SG501	24	78791	Spacer Ring for Grill ECO for SG501	54
37279	Lift Arm Right from 99 for SG501	14DX	78821	Screw 6x16 for SG501	27	78831	Bushing Flange D.12 for SG501	65
78749	Right Lifting Rod until 99 for SG501	14DX	78822	Screw 8x18 for SG501	28			
37296	Lift Arm Left from 99 for SG501	14SX	37310	Right Side Bracket for SG501	30DX			

Parts Breakdown

Model PG-IT-0737 11380

Item No.	Description	Position	Item No.	Description	Position	Item No.	Description	Position
37313	Bottom Plate Flat/Ribbed USA for SG501FBR	1	78750	Left Lifting Rod until 99 for SG501FBR	14SX	37311	Left Side Bracket for SG501FBR	30SX
78809	Bottom Surface - Flat/Ribbed for SG501FBR	1	37270	Brass Brake for SG501FBR	15	16480	Protection Spiral for SG501FBR	33
37307	Top Plate - Ribbed - Right USA for SG501FBR	2DX	23746	Lifting Pin 12mm for SG501FBR	16	37301	Top Wiring for SG501FBR	34
78815	Right Top Surface-Grooved for SG501FBR	2DX	37291	Balance Pin for SG501FBR	17	37302	Upper Wiring for SG501FBR	34
37308	Top Plate - Ribbed - Left USA for SG501FBR	2SX	19365	Handle Pin for SG501FBR	18	37273	Washer Dia.6 for SG501FBR	36
78816	Left Top Surface-Grooved for SG501FBR	2SX	16476	Right Spring from 99 for SG501FBR	19DX	19369	Spacer Ring for SG501FBR	37A
37298	Stainless Steel Base for SG501FBR	3	16475	Right Lifting Spring for SG501FBR	19DX	19368	Spacer Ring-External for SG501FBR	37B
78832	Frame INOX - PD ECO for SG501FBR	3	78817	Right Spring before 99 for SG501FBR	19DX	19372	Terminal Block for SG501FBR	38
37299	Bottom Enclosure Panel for SG501FBR	4	16477	Left Lifting Spring for SG501FBR	19SX	37303	Bottom Wiring for SG501FBR	40
78833	COP. INF. Galvanized TPO-PD R/L/M ECO for SG501FBR	4	16478	Left Spring from 99 for SG501FBR	19SX	78823	Bottom Wiring for SG501FBR	40B
37300	Stainless Steel Rear Cover for SG501FBR	5	19370	Lifting Handle for SG501FBR	20	37283	Power Cord 115V 15A USA for SG501FBR	41
18678	Stainless Steel Drip Tray for SG501FBR	6	78818	Lifting Handle Red for SG501FBR	20B	37276	Brush for SG501FBR	42
19366	Top Surface Cover for SG501FBR	7DX	78819	Lifting Handle Green for SG501FBR	20C	37304	Cable Gland for SG501FBR	43
37309	Upper Left Cover for SG501FBR	7SX	19371	Drip Tray Knob for SG501FBR	21A	37305	Strain Relief USA for SG501FBR	45
16471	Top Heating Element 220V for SG501FBR	8	78752	Knob CASS.Red for SG501FBR	21B	37306	Front Label for SG501FBR	50
16473	Bottom Heating Element 220V for SG501FBR	9	78820	Upper Knob Black for SG501FBR	22A	78790	MOSTR.Graduated 8x7cm for SG501FBR	50
16474	Thermostat 110/220-50/60 for SG501FBR	10	37282	Upper Knob for SG501FBR	22B	78828	Customized Faceplate for SG501FBR	50A
23749	Pilot Light 220V for SG501FBR	11	18001	Knob for SG501FBR	23A	78830	Timer Shield for SG501FBR	51
21103	Insulating Panel 110 ZK for SG501FBR	12	78754	Knob Red Color, Thermostat for SG501FBR	23B	78829	MONST. PERS/Neutral Timer for SG501FBR	51A
20881	Insulating Panel Protection for SG501FBR	13	18681	Foot for SG501FBR	24	78791	Spacer Ring for Grill ECO for SG501FBR	54
37279	Lift Arm Right from 99 for SG501FBR	14DX	78821	Screw 6x16 for SG501FBR	27	78831	Bushing Flange D.12 for SG501FBR	65
78749	Right Lifting Rod until 99 for SG501FBR	14DX	78822	Screw 8x18 for SG501FBR	28			
37296	Lift Arm Left from 99 for SG501FBR	14SX	37310	Right Side Bracket for SG501FBR	30DX			

Electrical Schematics

Model PG-IT-0483-R 11375

Model PG-IT-0483 11376

Model PG-IT-0610-R 11377

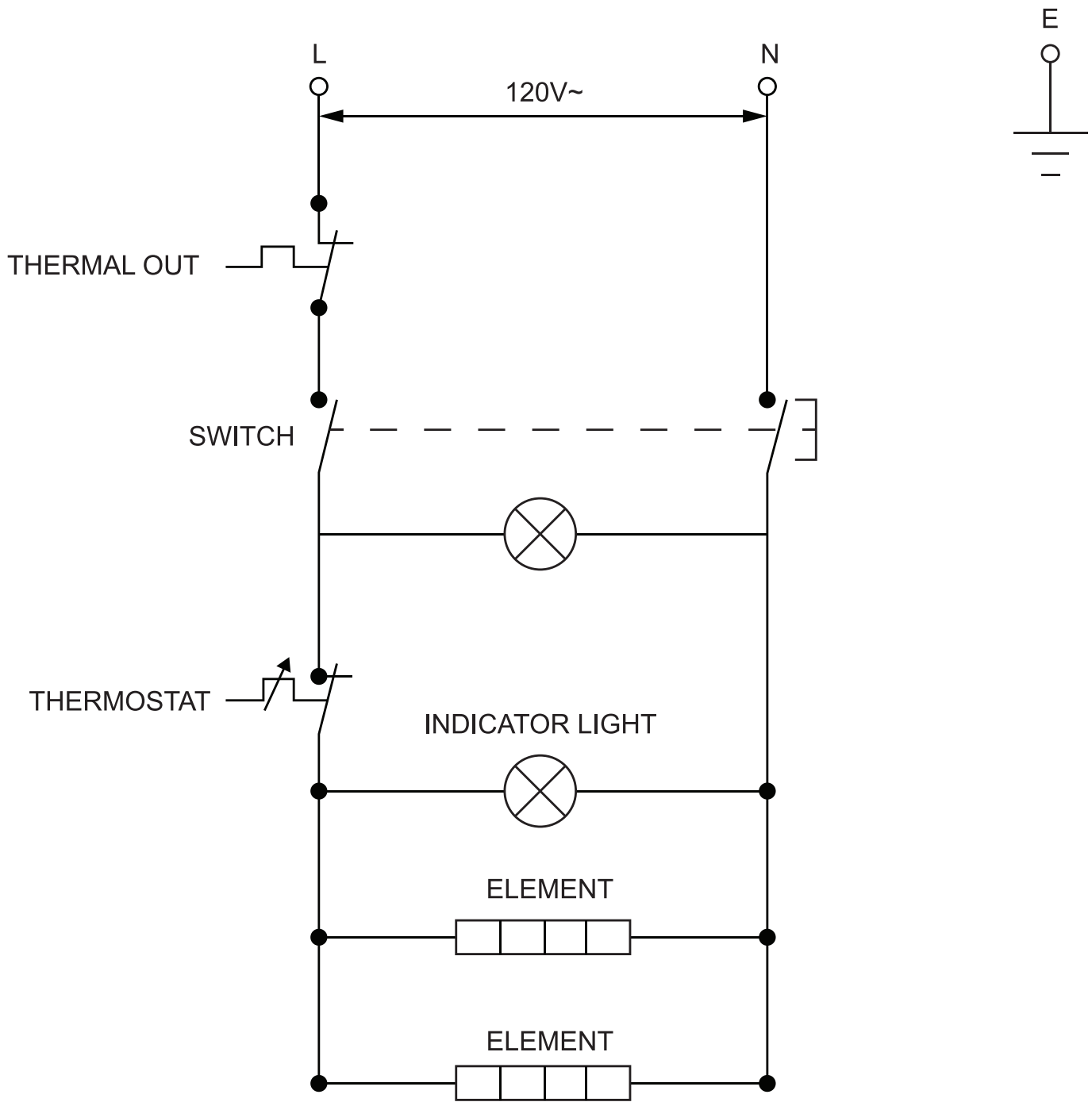

Electrical Schematics

Model PG-IT-0737-R 11378

Model PG-IT-0737 11380

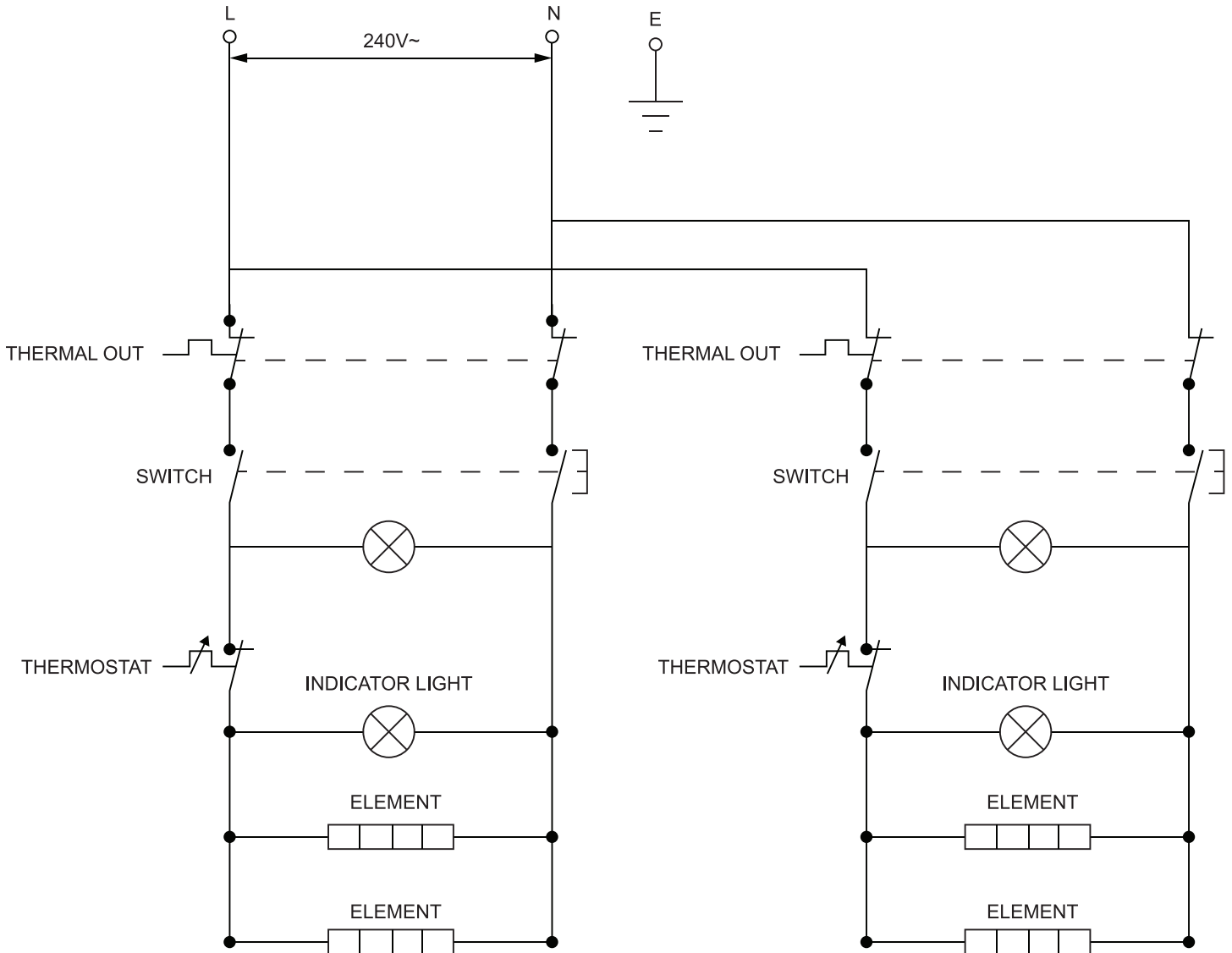



Warranty Registration

Thank you for purchasing an Omcan product. To register your warranty for this product, complete the information below, tear off the card at the perforation and then send to the address specified below. You can also register online by visiting:

Merci d'avoir acheté un produit Omcan. Pour enregistrer votre garantie pour ce produit, complétez les informations ci-dessous, détachez la carte au niveau de la perforation, puis l'envoyer à l'adresse spécifiée ci-dessous. Vous pouvez également vous inscrire en ligne en visitant:

Gracias por comprar un producto Omcan usted. Para registrar su garantía para este producto, complete la información a continuación, cortar la tarjeta en la perforación y luego enviarlo a la dirección indicada a continuación. También puede registrarse en línea en:

www.omcan.com/warrantyregistration.html

For mailing in Canada

Pour postale au Canada

Por correo en Canadá

For mailing in the US

Pour diffusion aux États-Unis

Por correo en los EE.UU.

OMCAN

PRODUCT WARRANTY REGISTRATION

3115 Pepper Mill Court,

Mississauga, Ontario

Canada, L5L 4X5

OMCAN

PRODUCT WARRANTY REGISTRATION

4450 Witmer Industrial Estates, Unit 4,

Niagara Falls, New York

USA, 14305

or email to: service@omcan.com



Purchaser's Information

Name: _____

Company Name: _____

Address: _____

Telephone: _____

City: _____ Province or State: _____ Postal or Zip: _____

Email Address: _____

Country: _____

Type of Company:

Restaurant Bakery Deli

Butcher Supermarket Caterer

Institution (*specify*): _____

Other (*specify*): _____

Dealer from which Purchased: _____

Dealer City: _____ Dealer Province or State: _____

Invoice: _____

Model Name: _____ Model Number: _____

Serial Number: _____

Machine Description: _____

Date of Purchase (MM/DD/YYYY): _____

Date of Installation (MM/DD/YYYY): _____

Would you like to extend the warranty? Yes No

Thank you for choosing Omcan | Merci d'avoir choisi Omcan | Gracias por elegir Omcan



Since 1951 Omcan has grown to become a leading distributor of equipment and supplies to the North American food service industry. Our success over these many years can be attributed to our commitment to strengthen and develop new and existing relationships with our valued customers and manufacturers. Today with partners in North America, Europe, Asia and South America, we continually work to improve and grow the company. We strive to offer customers exceptional value through our qualified local sales and service representatives who provide convenient access to over 3, 500 globally sourced products.

Depuis 1951 Omcan a grandi pour devenir un des “leaders” de la distribution des équipements et matériel pour l’industrie des services alimentaires en Amérique du Nord. Notre succès au cours de ces nombreuses années peut être attribué à notre engagement à renforcer et à développer de nouvelles et existantes relations avec nos clients et les fabricants de valeur. Aujourd’hui avec des partenaires en Amérique du Nord, Europe, Asie et Amérique du Sud, nous travaillons continuellement à améliorer et développer l’entreprise. Nous nous efforçons d’offrir à nos clients une valeur exceptionnelle grâce à nos ventes locales qualifiées et des représentants de service qui offrent un accès facile à plus de 3500 produits provenant du monde entier.

Desde 1951 Omcan ha crecido hasta convertirse en un líder en la distribución de equipos y suministros de alimentos en América del Norte industria de servicios. Nuestro éxito en estos años se puede atribuir a nuestro compromiso de fortalecer y desarrollar nuevas relaciones existentes con nuestros valiosos clientes y fabricantes. Hoy con socios de América del Norte, Europa, Asia y América del Sur, que trabajan continuamente para mejorar y crecer la empresa. Nos esforzamos por ofrecer a nuestros clientes valor excepcional a través de nuestro local de ventas y representantes de los servicios que proporcionan un fácil acceso a más de 3, 500 productos con origen a nivel mundial.

