



Refrigerated Sandwich Prep Units

Models PT-CN-0686-HC, 1194-HC, 1524-HC, 1778-HC, 0711-HC,
1194-H, 1537-HC

Items 50045, 50046, 50047, 50048, 50049, 50050, 50051

Instruction Manual



Revised - 08/29/2019



Toll Free: 1-800-465-0234
Fax: 905-607-0234
Email: service@omcan.com
www.omcan.com

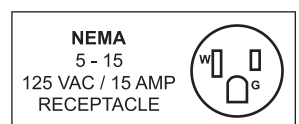

Table of Contents

Model PT-CN-0686-HC / Model PT-CN-1194-HC / Model PT-CN-1524-HC
Model PT-CN-1778-HC / Model PT-CN-0711-HC / Model PT-CN-1194-H
Model PT-CN-1537-HC

Section	Page
General Information -----	3 - 4
Safety and Warranty -----	4 - 5
Technical Specifications -----	6 - 7
Installation -----	7 - 9
Maintenance -----	9 - 10
Troubleshooting -----	10 - 11
Controller Instructions -----	12 - 14
Parts Breakdown -----	15 - 28
Electrical Schematics -----	29 - 35
Notes -----	36 - 38
Warranty Registration -----	39



General Information

Omcan Manufacturing and Distributing Company Inc., Food Machinery of America, Inc. dba Omcan and Omcan Inc. are not responsible for any harm or injury caused due to any person's improper or negligent use of this equipment. The product shall only be operated by someone over the age of 18, of sound mind, and not under the influence of any drugs or alcohol, who has been trained in the correct operation of this machine, and is wearing authorized, proper safety clothing. Any modification to the machine voids any warranty, and may cause harm to individuals using the machine or in the vicinity of the machine while in operation.

CHECK PACKAGE UPON ARRIVAL

Upon receipt of an Omcan shipment please inspect for external damage. If no damage is evident on the external packaging, open carton to ensure all ordered items are within the box, and there is no concealed damage to the machine. If the package has suffered rough handling, bumps or damage (visible or concealed), please note it on the bill of lading before accepting the delivery and contact Omcan within 24 hours, so we may initiate a claim with the carrier. A detailed report on the extent of the damage caused to the machine must be filled out within three days, from the delivery date shown in the shipping documents. Omcan has no recourse for damaged products that were shipped collect or third party.

Before operating any equipment, always read and familiarize yourself with all operation and safety instructions.

Omcan would like to thank you for purchasing this machine. It's of the utmost importance to save these instructions for future reference. Also save the original box and packaging for shipping the equipment if servicing or returning of the machine is required.

Omcan Fabrication et distribution Compañie Limité et Food Machinery d'Amérique, dba Omcan et Omcan Inc. ne sont pas responsables de tout dommage ou blessure causé du fait que toute personne ait utilisé cet équipement de façon irrégulière. Le produit ne doit être exploité que par quelqu'un de plus de 18 ans, saine d'esprit, et pas sous l'influence d'une drogue ou d'alcool, qui a été formé pour utiliser cette machine correctement, et est vêtu de vêtements de sécurité approprié. Toute modification de la machine annule toute garantie, et peut causer un préjudice à des personnes utilisant la machine ou des personnes à proximité de la machine pendant son fonctionnement.

VÉRIFIEZ LE COLIS DÈS RÉCEPTION

Dès réception d'une expédition d'Omcan veuillez inspecter pour dommages externes. Si aucun dommage n'est visible sur l'emballage externe, ouvrez le carton afin de s'assurer que tous les éléments commandés sont dans la boîte, et il n'y a aucun dommage dissimulé à la machine. Si le colis n'a subi aucune mauvaises manipulations, de bosses ou de dommages (visible ou cachée), notez-le sur le bond de livraison avant d'accepter la livraison et contactez Omcan dans les 24 heures qui suivent, pour que nous puissions engager une réclamation auprès du transporteur. Un rapport détaillé sur l'étendue des dommages causés à la machine doit être rempli dans un délai de trois jours, à compter de la date de livraison indiquée dans les documents d'expédition. Omcan n'a aucun droit de recours pour les produits endommagés qui ont été expédiés ou cueilli par un tiers transporteur.

General Information

Avant d'utiliser n'importe quel équipement, toujours lire et vous familiariser avec toutes les opérations et les consignes de sécurité.

Omcan voudrais vous remercier d'avoir choisi cette machine. Il est primordial de conserver ces instructions pour une référence ultérieure. Également conservez la boîte originale et l'emballage pour l'expédition de l'équipement si l'entretien ou le retour de la machine est nécessaire.

Omcan Empresa De Fabricacion Y Distribucion Inc. Y Maquinaria De Alimentos De America, Inc. dba Omcan y Omcan Inc. no son responsables de ningun daño o perjuicio causado por cualquier persona inadecuada o el uso descuidado de este equipo. El producto solo podra ser operado por una persona mayor de 18 años, en su sano juicio y no bajo alguna influencia de droga o alcohol, y que este ha sido entrenado en el correcto funcionamiento de esta máquina, y ésta usando ropa apropiada y autorizada. Cualquier modificación a la máquina anula la garantía y puede causar daños a las personas usando la máquina mientras esta en el funcionamiento.

REVISE EL PAQUETE A SU LLEGADA

Tras la recepcion de un envio Omcan favor inspeccionar daños externos. Si no hay daños evidentes en el empaque exterior, Habra el carton para asegurarse que todos los articulos solicitados estén dentro de la caja y no encuentre daños ocultos en la máquina. Si el paquete ha sufrido un manejo de poco cuidado, golpes o daños (visible o oculto) por favor anote en la factura antes de aceptar la entrega y contacte Omcan dentro de las 24 horas, de modo que podamos iniciar una reclamación con la compañía. Un informe detallado sobre los daños causados a la máquina debe ser llenado en el plazo de tres días, desde la fecha de entrega que se muestra en los documentos de envío. Omcan no tiene ningun recurso por productos dañados que se enviaron a recoger por terceros.

Antes de utilizar cualquier equipo, siempre lea y familiarizarse con todas las instrucciones de funcionamiento y seguridad.

Omcan le gustaría darle las gracias por la compra de esta máquina. Es de la mayor importancia para salvar estas instrucciones para futuras consultas. Además, guarda la caja original y el embalaje para el envío del equipo si servicio técnico o devolución de la máquina que se requiere.

Safety and Warranty

Please pay close attention to the safety notices in this section. Disregarding these notices may lead to serious injury and/or damage to the unit.

ATTENTION

- To minimize shock and fire hazards, be sure not to overload outlet. Please designate one outlet for your unit.



Safety and Warranty

- Do not use extension cords.
- Do not put your hands under the unit when the unit is required to be moved.
- When the unit is not in use for a long period of time, please unplug the unit from the outlet.
- After unplugging the unit, wait at least 10 minutes before re-plugging it. Failure to do so could cause damage to the compressor.

UNPLUG CORD

- To minimize shock and fire hazards, please do not plug or unplug the cord with wet hands.
- During maintenance and cleaning, please unplug the unit.

PROPER GROUNDING REQUIRED

- To minimize shock and fire hazards, make sure that the unit is properly grounded.

PROHIBITION

- Do not attempt to remove or repair any component unless instructed by factory.
- Make sure that the unit is not resting on or against the electrical cord and plug.
- To minimize personal injury, do not hang on the doors.
- Do not store any flammable and explosive gas or liquids inside the unit.
- Do not attempt to alter or tamper with the electrical cord.

2 YEARS PARTS AND LABOUR / 5 YEARS PARTS ONLY ON COMPRESSOR WARRANTY

Within the warranty period, contact Omcan Inc. at 1-800-465-0234 to schedule an Omcan authorized service technician to repair the equipment locally.

Unauthorized maintenance will void the warranty. Warranty covers electrical and part failures, not improper use.

Please see <https://omcan.com/disclaimer> for complete info.

WARNING:

The packaging components are classified as normal solid urban waste and can therefore be disposed of without difficulty.

In any case, for suitable recycling, we suggest disposing of the products separately (differentiated waste) according to the current norms.

DO NOT DISCARD ANY PACKAGING MATERIALS IN THE ENVIRONMENT!

Technical Specifications

REFRIGERATED PREP TABLES

Model	PT-CN-0686-HC	PT-CN-1194-HC	PT-CN-1524-HC	PT-CN-1778-HC
Temperature Range	0.5°C -5°C / 33°F - 41°F			
Max Ambient Temperature Rating	32°C / 90°F			
Horsepower	1/5 HP	1/4 HP		3/4 HP
Electrical	110V / 60Hz / 1Ph			
Amps	2.9A	4.6A	4.8A	8.9A
Refrigerant	R290			
Isolation Material	Cyclopentane			
Cooling System	Ventilated			
Insert Capacity	6 - 1/6 pans 2 - 1/9 pans	12 - 1/6 pans 6 - 1/3 pans	16 - 1/6 pans	18 - 1/6 pans
Number of Doors	1	2		3
Number of Shelves	1	2		3
Shelf Capacity	44 lbs. / 20 kgs.	40 lbs. / 18 kgs.	52.9 lbs. / 24 kgs.	44 lbs. / 20 kgs.
Cutting Board	27.4" x 10.3" x 0.4" 696 x 262 x 10mm	47" x 10.3" x 0.4" 1186 x 262 x 10mm	60.1" x 10.3" x 0.4" 1527 x 262 x 10mm	70.3" x 10.3" x 0.4" 1786 x 262 x 10mm
Exterior Dimensions	27.5" x 29.5" x 42.4" 698 x 750 x 1075mm	46.9" x 29.5" x 42.4" 1188 x 750 x 1075mm	60" x 29.5" x 42.4" 1529 x 750 x 1075mm	70.4" x 29.5" x 42.4" 1787 x 750 x 1075mm
Interior Dimensions	24" x 23.8" x 23.5" 611 x 605 x 597mm	42.8" x 23.8" x 23.5" 1088 x 605 x 597mm	56" x 23.8" x 23.5" 1429 x 605 x 597mm	66" x 24" x 23.5" 1687 x 605 x 597mm
Net Volume	160 L / 5.7 cu.ft.	268 L / 9.5 cu.ft.	428 L / 15.1 cu.ft.	440 L / 15.5 cu.ft.
Weight	187 lbs. / 85 kgs.	271 lbs. / 123 kgs.	319 lbs. / 145 kgs.	378 lbs. / 172 kgs.
Item Number	50045	50046	50047	50048



Technical Specifications

MEGA REFRIGERATED PREP TABLES

Model	PT-CN-0711-HC	PT-CN-1194-H	PT-CN-1537-HC
Temperature Range	0.5°C ~ 5°C / 33°F ~ 41°F		
Max Ambient Temperature Rating	32°C / 90°F		
Horsepower	1/5 HP	1/4 HP	
Electrical	110V / 60Hz / 1Ph		
Amps	2.9A	4.6A	4.8A
Refrigerant	R290		
Isolation Material	Cyclopentane		
Cooling System	Ventilated		
Insert Capacity	9 - 1/6 pans	18 - 1/6 pans	21 - 1/6 pans
Number of Doors	1	2	
Number of Shelves	1	2	
Shelf Capacity	77 lbs. / 35 kgs.		158.7 lbs. / 72 kgs.
Net Volume	161 L / 5.7 cu.ft.	269 L / 9.5 cu.ft.	425 L / 15 cu.ft.
Exterior Dimensions	27.5" x 34" x 46" 698 x 864 x 1166mm	47" x 34" x 46" 1194 x 864 x 1166mm	60.2" x 34" x 46" 1529 x 864 x 1166mm
Interior Dimensions	24" x 23.8" x 23.5" 610 x 605 x 597mm	42.8" x 23.8" x 23.5" 1088 x 605 x 597mm	56.3" x 23.8" x 23.5" 1430 x 605 x 597mm
Weight	198 lbs. / 90 kgs.	298 lbs. / 135.2 kgs.	330 lbs. / 149.7 kgs.
Item Number	50049	50050	50051

Installation

IMPORTANT!!!PLEASE READ BEFORE INSTALLATION

- If the unit has recently been transported. Please let unit stand still for a minimum of 24 hours before plugging it in.
- Make sure that the unit drops down to desired temperature before loading the unit with product.
- Make sure that there is proper ventilation around the unit in the area where it will operate.
- Make sure all accessories are installed(i.e. shelves, shelf clips, casters) before plugging the unit in.
- Please read through the Operation / Owner's Manual in its entirety.

CABINET LOCATION GUIDELINES

- Install the unit on strong and leveled surfaces.
 - Unit may make unpleasant noises if surface is uneven.
 - Unit may malfunction if surface is uneven.

Installation

- Install the unit in an indoor, well-ventilated area.
 - Unit performs more efficiently in a well-ventilated area.
 - For best performance, please maintain clearance of 6" on the back of the unit.
 - Outdoor use may cause decreased efficiency and damage to the unit.
- Avoid installation in a high humidity and/or dusty area.
 - Humidity could cause unit to rust and decrease efficiency of the unit.
 - Dust collected on condenser coil will cause unit to malfunction. Clean the condenser at least once a month with a brush or clean cloth.
 - Malfunction due to dirty condenser will void warranty.
- Select a location away from heat and moisture-generating equipment.
 - High ambient temperature will cause the compressor to overwork, leading to higher energy bills and gradual breakdown of the unit.
 - Malfunction due to high ambient temperature will void warranty.

ELECTRICAL

Please ensure that the required voltage of the compressor is being supplied at all times. Low or high voltage can detrimentally affect the refrigeration unit. All units should be plugged into a grounded and properly-sized electrical outlet with appropriate overcurrent protection. Please refer to the electrical requirement on the nameplate of the unit. Please make sure that your unit has its own dedicated outlet. Do not use an extension cord.

TEMPERATURE CONTROLS

The temperature controls are factory-set to maintain an average temperature of 38°F in refrigeration. To maintain a different temperature, adjust it on the temperature controller—see *manual of temperature controller*.

CAUTION

Setting the temperature control to the coldest setting may cause the evaporator coil to freeze and ice up. This will eventually result in a warmer cabinet temperature.

LOADING PRODUCT

Shelves have been factory-installed for your convenience. Before loading shelves, please be sure that all shelf clips are completely fastened in their correct locations. It is important that all shelves rest completely level before stocking your cabinet with product. In order to maintain correct air flow inside the unit, please be sure to leave two to four (2 to 4) inches of space between the back wall and stored product. Blocking the evaporator fans will result in a warmer cabinet temperature, and ultimately compressor failure.

DEFROST SYSTEMS

Refrigerator coils are kept below the freezing point (32°F). During compressor down-time, the evaporator fan continues to circulate air through the evaporator coil. This air circulation raises the coil temperature above the

Installation

freezing point, melting any accumulated frost. Run-off water is drained into the evaporator pan and evaporated. Freezer coils are defrosted electrically. Automatic defrost timers are built-in to the refrigeration system and may not be adjusted. The defrost timers automatically initiate at pre-set intervals and for a pre-determined duration.

PLEASE NOTE: Excessive door opening should be avoided in order to maintain cabinet temperature and to eliminate the possibility of coil freeze-up.

LOADING FOOD PANS

Pizza prep units and sandwich prep units are designed to function with all pans in place, even if some pans are to be left empty. For maximum food freshness, Fill the pans only with an amount that can be used in a specific usage period. During non-use, please close the insulated lid cover.

REVERSING THE DOORS (OPTIONAL)

Note: This only applies to the single door units.

Only perform these steps with another person present to ensure the door does not fall over.

1. Open the door.
2. Remove the screws from the top panel, then open the top panel.
3. Remove the screws of the bottom louver, then remove the louver.
4. Unscrew all of the screws from the upper hinge
5. Unscrew all of the screws from the lower hinge and remove the door and hinges.
6. Place the former upper hinge at the bottom of the unit, parallel to where the lower hinge is, do the same with the former lower hinge except for the top. Screw the hinges into place.
7. Reassemble the door so it is facing the opposite direction.
8. Reassemble the top panel and the lower louver.
9. The door is now reversed.

Maintenance

CLEANING THE CONDENSER COIL

- For efficient operation, it is important that the condenser surface be kept free of dust, dirt, and lint.
- We recommend cleaning the condenser coil and fins at least once per month.
- Clean with a commercial condenser coil cleaner, available from any kitchen equipment retailer. Brush the condenser fins from top to bottom, not side to side.
- After cleaning, straighten any bent condenser fins with a fin comb.

CLEANING THE FAN BLADE AND MOTOR

- If necessary, clean the fan blades and motor with a soft cloth, If it is necessary to wash the fan blades,

Maintenance

cover the fan motor to prevent moisture damage.

CLEANING THE INTERIOR OF UNIT

- When cleaning the cabinet interior, use a solvent of warm water and mild soap.
- Do not use steel wool, caustic soap, abrasive cleaners, or bleach that may damage the stainless steel surface.
- Wash door gaskets on a regular basis, preferably weekly. Simply remove door gasket from the frame of the door, soak in warm water and soap for thirty (30) minutes, dry with soft cloth, and replace.
- Check door gaskets for proper seal after they are replaced.
- Periodically remove the shelves and pilasters from the unit and clean them with mild soap and warm water. To remove the pilasters, first remove the shelves and shelf brackets. Then, simply lift the pilaster up and out.

WARNING

Disconnect power cord before cleaning any parts of the unit.

Troubleshooting

Before requesting any service on your unit, please check the following points. Please note that this guide serve only as a reference for solutions to common problems.

SYMPTOM	POSSIBLE CAUSE	CORRECTIVE ACTION
Compressor not running.	Fuse blown or circuit breaker tripped.	Replace fuse or reset circuit breaker.
	Power cord unplugged.	Plug in power cord.
	Thermostat set too high.	Set thermostat to lower Temperature.
	Cabinet in defrost cycle.	Wait for defrost cycle to finish.

Troubleshooting

Condensing unit runs for long periods of time.	Excessive amount of warm product Placed in cabinet.	Allow adequate time for Product to cool down.
	Prolonged door opening or door ajar.	Ensure doors are closed when not in use. Avoid opening doors for long periods of time.
	Door gasket(s) not sealing properly.	Ensure gaskets are snapped in Completely. Remove gasket and Wash with soap and water.
		Check condition of gasket and replace if necessary.
	Dirty condenser coil.	Clean the condenser coil.
	Evaporator coil iced over.	Unplug unit and allow coil to defrost. Make sure thermostat is not set too cold. Ensure that door gasket(s) are sealing properly.
Cabinet is noisy.	Loose part(s).	Locate and tighten loose part(s).
	Tubing vibration.	Ensure tubing is free from contact with other tubing or components.
Cabinet Temperature Is too warm.	Thermostat set too warm.	Set thermostat to lower Temperature.
	Blocking air flow.	Re-arrange product to allow for Proper air flow. Make sure there Is at least four inches of clearance from evaporator.
	Excessive amount of warm product Placed in cabinet.	Allow adequate time for product to cool down.
	Fuse blown or circuit breaker tripped.	Replace fuse or reset circuit breaker.
	Dirty condenser coil.	Clean the condenser coil.
	Prolonged door opening or door ajar.	Ensure doors are closed when not in use. Avoid opening doors for long periods of time.
	Evaporator coil iced over.	Unplug unit and allow coil to defrost. Make sure thermostat is not set too cold. Ensure that door gasket(s) are sealing properly.

For service call 1-800-465-0234.

Controller Instructions

Digital controller model: PJEZ for cooler





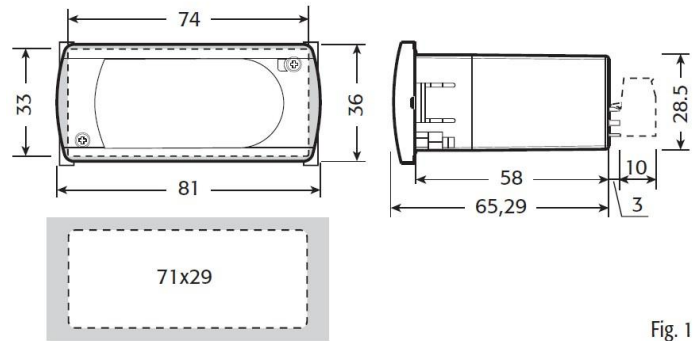

Dimensioni (mm) / Dimensions (mm)



Display and functions



During normal operation, the controller displays the value of the probe set using parameter/4(=1 ambient probe, default, = 2 second probe, = 3 third probe). In addition, the display has LEDs that indicate the activation of the control functions (see Table 1), while the 3 buttons can be used to activate/deactivate some of the functions(see Table 2).

LED's and Associated Functions (Table 1)

Icon	Function	Normal Operation			Start Up
		ON	OFF	Blink	
	Compressor	On	Off	Request	ON
	Fan	On	Off	Request	ON
	Defrost	On	Off	Request	ON
<i>AUX</i>	Aux	Output On	Output Off	-	ON
	Alarm	All	No Alarm	-	ON
	Clock	RTC fitted and enabled, at least 1 time band set	RTC not fitted or disabled, not even 1 time band set	-	ON if RTC fitted

Controller Instructions

Table of Functions activated by the buttons - Models S, X, Y, C (Table 2)

Button		Normal Operation		Start Up	
		Pressing the Button Alone	Pressed Together		
	Up ON/OFF	More than 3 sec: toggle ON/OFF	Start/Stop continuous cycle	-	
	Down Defrost	More than 3 sec: start/stop defrost			
	Set Mute	- 1 sec.: display/set the set point. - more than 3 secs.: access parameter setting menu (enter password) - mute audible alarm (buzzer)	-	Pressed together Start parameter reset procedure	For 1 sec. display firmware vers. code
					For 1 sec. RESET current EZY set

Setting the set point (desired temperature)

- press **SET** for 1 sec, the set value will start flashing after a few moments;
- increase or decrease the value using **UP** or **DOWN**;
- press **SET** to confirm the new value.

Switching the device ON/OFF

Press **UP** for more than 3 sec. The control and defrost algorithms are now disabled and the Instrument displays the message “OFF” alternating with the temperature read by the set probe

Manual defrost

Press for **DOWN** more than 3 sec (the defrost starts only the temperature conditions are valid).

Continuous cycle

Press **UP** and **DOWN** together for more than 3 sec

Access and setting type F (frequent) and type C (configuration) parameters

1. press **SET** for 3 sec (the display will show “PS”);
2. • to access the type F and C parameter menu, enter the password “22” using **UP/DOWN**, press **SET** to confirm;
• to access the F parameter menu only, press **SET** (without entering the password);
3. scroll inside the parameter menu using **UP/DOWN**;

Controller Instructions

• to display/set the values of the parameter displayed, press **SET**, then **UP/DOWN** and finally **SET** to confirm the changes (returning to the parameter menu).

To save all the new values and exit the parameter menu, press **SET** for 3 s;

To exit the menu without saving the changed values (exit by timeout) do not press any button for at least 60 s.

REFERENCE

Item Number	Model Number	Description	Manufacturer Model Number
50045	PT-CN-0686-HC	Refrigerated Prep Table 27" / 686mm 110V/60/1 ETL cETLus	SCL1-HC
50046	PT-CN-1194-HC	Refrigerated Prep Table 47" / 1194mm 110V/60/1 ETL cETLus	SCL2-HC
50047	PT-CN-1524-HC	Refrigerated Prep Table 60" / 1524mm 110V/60/1 ETL cETLus	SCL2-60-HC
50048	PT-CN-1778-HC	Refrigerated Prep Table 70" / 1778mm 110V/60/1 ETL cETLus	SCL3-HC
50049	PT-CN-0711-HC	Refrigerated Prep Table Mega 28" / 711mm 110V/60/1 ETL cETLus	SCLM1-HC
50050	PT-CN-1194-H	Refrigerated Prep Table Mega 47" / 1194mm 110V/60/1 ETL cETLus	SCLM2-HC
50051	PT-CN-1537-HC	Refrigerated Prep Table Mega 61" / 1537mm 110V/60/1 ETL cETLus	SCLM2-60-HC

Parts Breakdown

Model PT-CN-0686-HC 50045

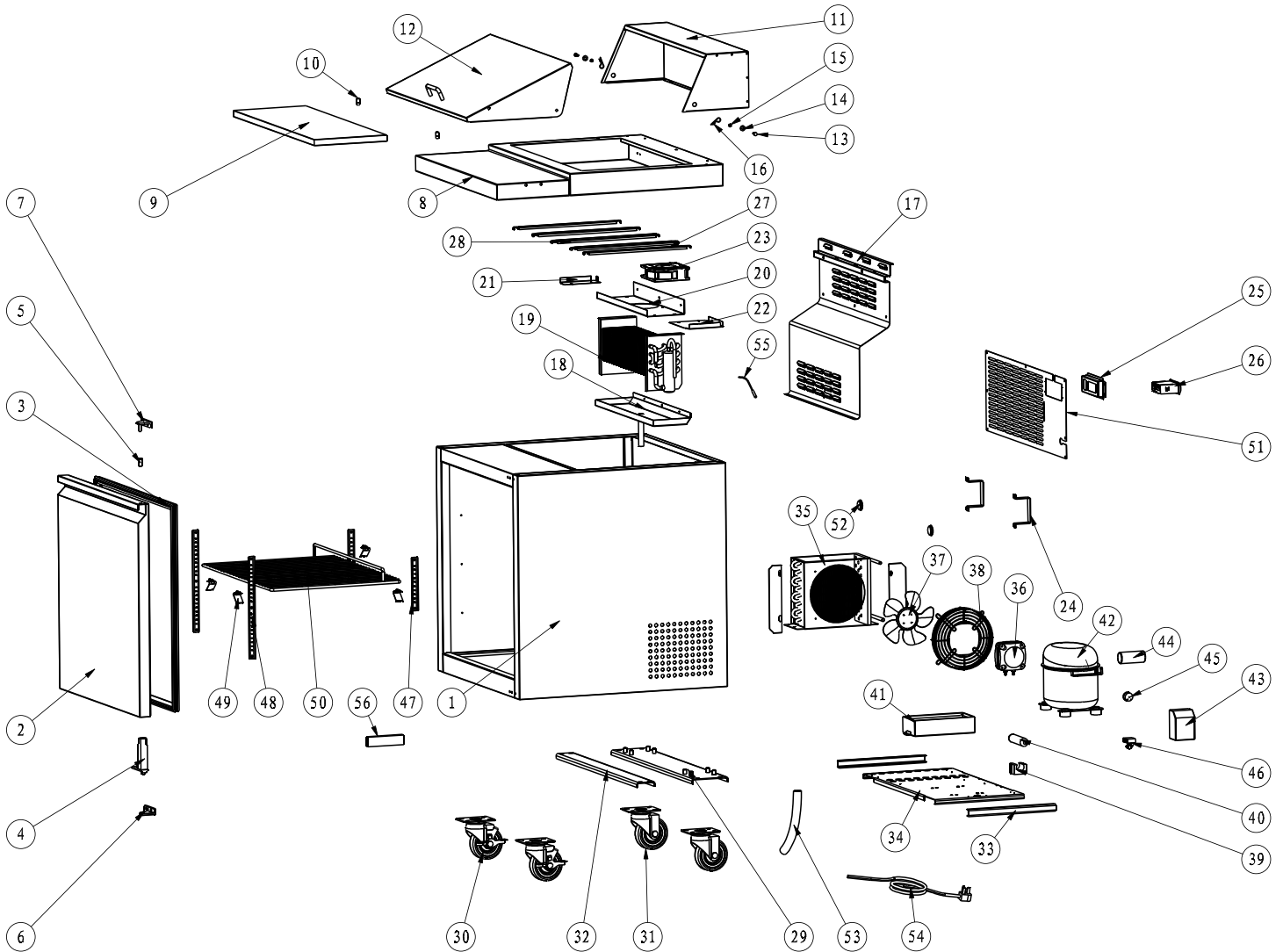

Parts Breakdown

Model PT-CN-0686-HC 50045

Item No.	Description	Position	Item No.	Description	Position	Item No.	Description	Position
AB248	Cabinet for SCL1-HC	1	AA118	Evaporator for SCL1-HC	19	AA208	Blade of Condenser Fan Motor for SCL1-HC	37
AB249	Door for SCL1-HC	2	AB262	Fan Motor Installation Panel for SCL1-HC	20	AA207	Condenser Fan Cover for SCL1-HC	38
AB250	Gasket for SCL1-HC	3	AB263	Left Clapboard of Evaporator for SCL1-HC	21	AA129	Filter Fixer for SCL1-HC	39
AA955	Spring Hinge Board for SCL1-HC	4	AB264	Right Clapboard of Evaporator for SCL1-HC	22	AA371	Filter for SCL1-HC	40
AA388	Axis Cover for SCL1-HC	5	AA128	Evaporator Fan Motor for SCL1-HC	23	AB274	Outer Drain Pan for SCL1-HC	41
AA360	Bottom Right Hinge for SCL1-HC	6	AB265	Stand Off Bracket for SCL1-HC	24	64167	Compressor for SCL1-HC	42
AA359	Upper Right Hinge for SCL1-HC	7	AB266	Thermostat Installation Board for SCL1-HC	25	AB275	Starter Kit for SCL1-HC	43 - 46
AB251	Top Board for SCL1-HC	8	AB267	Thermostat for SCL1-HC	26	AB276	K Strip-2 Holes for SCL1-HC	47
AB252	Cutting Board for SCL1-HC	9	AB268	Pan Bracket-15 for SCL1-HC	27	AB277	K Strip-3 Holes for SCL1-HC	48
AB253	Fixer for Cutting Board for SCL1-HC	10	AB269	Pan Bracket-25 for SCL1-HC	28	AB278	K Clip for SCL1-HC	49
AB254	Back Cover for SCL1-HC	11	AB270	Castor Support for SCL1-HC	29	AB279	Shelf for SCL1-HC	50
AB255	Lid for SCL1-HC	12	AA584	4" Castor with Brake for SCL1-HC	30	AB280	Back Grill for SCL1-HC	51
AB256	Dowel for SCL1-HC	13	AA743	4" Castor for SCL1-HC	31	AB169	Foaming Hole Cover for SCL1-HC	52
AB257	Plastic Bolt for SCL1-HC	14	AB271	Assembling Panel Support for SCL1-HC	32	AA133	Drain Hose for SCL1-HC	53
AB258	Nut for SCL1-HC	15	AB272	Compressor Unit Track for SCL1-HC	33	AA135	Power Cord for SCL1-HC	54
AB259	Split Pin for SCL1-HC	16	AB273	Compressor Unit Installation Board for SCL1-HC	34	AA379	Temperature Sensor of Cabinet Inside for SCL1-HC	55
AB260	Evaporator Cover for SCL1-HC	17	AB159	Condenser for SCL1-HC	35	AA596	Thermometer for SCL1-HC	56
AB261	Inner Drain Pan for SCL1-HC	18	AA607	Condenser Fan Motor for SCL1-HC	36			

Parts Breakdown

Model PT-CN-1194-HC 50046

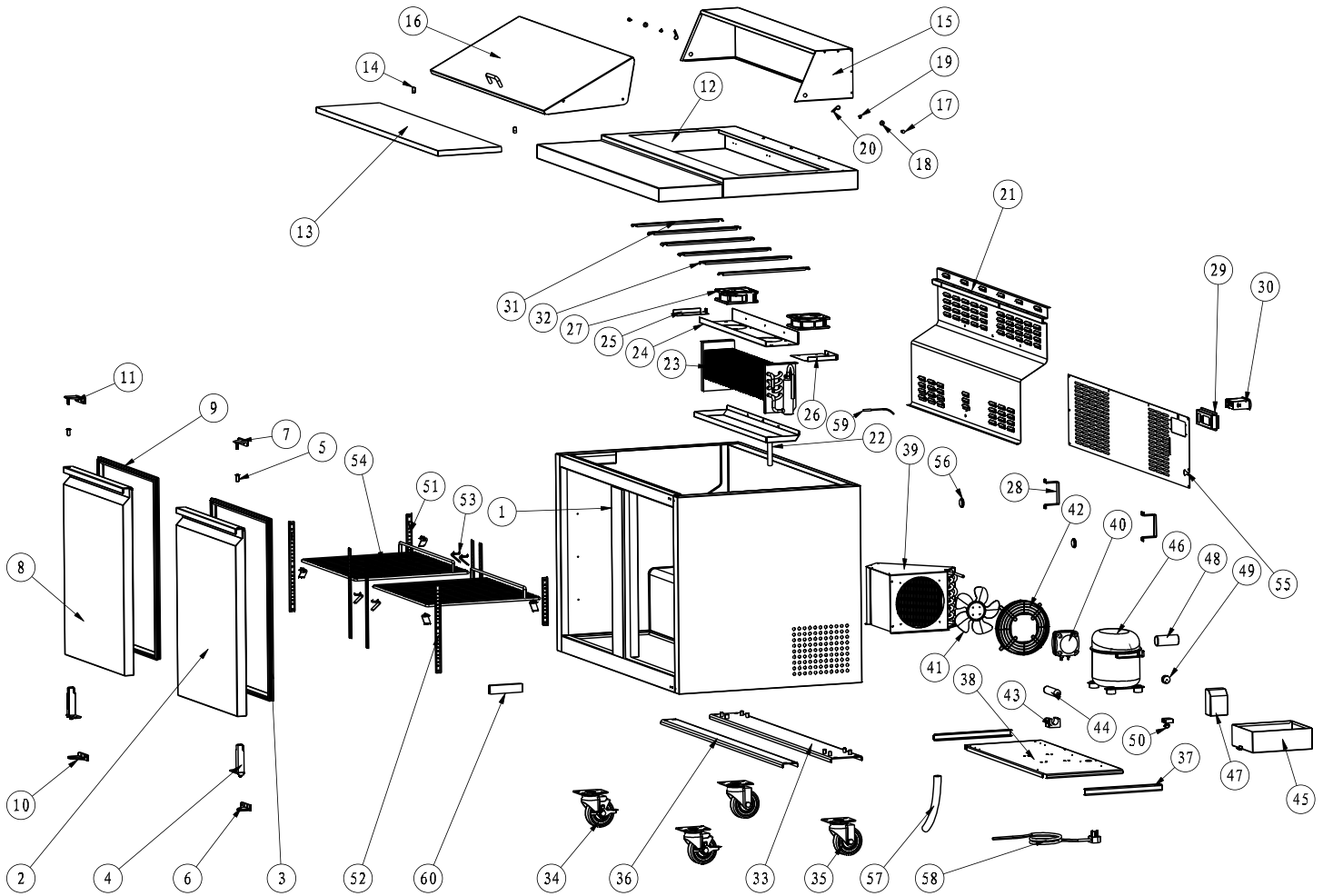

Parts Breakdown

Model PT-CN-1194-HC 50046

Item No.	Description	Position	Item No.	Description	Position	Item No.	Description	Position
AB307	Cabinet for SCL2-HC	1	AB259	Split Pin for SCL2-HC	20	AB213	Condenser for SCL2-HC	39
AB308	Right Door for SCL2-HC	2	AB314	Evaporator Cover for SCL2-HC	21	AB049	Condenser Fan Motor for SCL2-HC	40
AB197	Gasket for SCL2-HC	3	AB315	Inner Drain Pan for SCL2-HC	22	AA208	Blade of Condenser Fan Motor for SCL2-HC	41
AA955	Spring Hinge Board for SCL2-HC	4	AA150	Evaporator for SCL2-HC	23	AA207	Condenser Fan Cover for SCL2-HC	42
AA388	Axis Cover for SCL2-HC	5	AB316	Fan Motor Installation Panel for SCL2-HC	24	AA129	Filter Fixer for SCL2-HC	43
AA360	Bottom Right Hinge for SCL2-HC	6	AB317	Left Clapboard of Evaporator for SCL2-HC	25	AA371	Filter for SCL2-HC	44
AA359	Upper Right Hinge for SCL2-HC	7	AB318	Right Clapboard of Evaporator for SCL2-HC	26	AB328	Outer Drain Pan for SCL2-HC	45
AB309	Left Door for SCL2-HC	8	AA128	Evaporator Fan Motor for SCL2-HC	27	64168	Compressor for SCL2-HC	46
AB197	Gasket for SCL2-HC	9	AB319	Stand Off Bracket for SCL2-HC	28	AB329	Starter Kit for SCL2-HC	47 - 50
61468	Bottom Left Hinge for SCL2-HC	10	AB320	Thermostat Installation Board for SCL2-HC	29	AB330	K Strip-2 Holes for SCL2-HC	51
AB200	Upper Left Hinge for SCL2-HC	11	AB321	Thermostat for SCL2-HC	30	AB331	K Strip-3 Holes for SCL2-HC	52
AB310	Top Board for SCL2-HC	12	AB322	Pan Bracket-15 for SCL2-HC	31	AB332	K Clip for SCL2-HC	53
AB311	Cutting Board for SCL2-HC	13	AB323	Pan Bracket-25 for SCL2-HC	32	AB220	Shelf for SCL2-HC	54
AB253	Fixer for Cutting Board for SCL2-HC	14	AB324	Castor Support for SCL2-HC	33	AB333	Back Grill for SCL2-HC	55
AB312	Back Cover for SCL2-HC	15	AA584	4" Castor with Brake for SCL2-HC	34	AB169	Foaming Hole Cover for SCL2-HC	56
AB313	Lid for SCL2-HC	16	AA743	4" Castor for SCL2-HC	35	AA133	Drain Hose for SCL2-HC	57
AB256	Dowel for SCL2-HC	17	AB325	Assembling Panel Support for SCL2-HC	36	AA135	Power Cord for SCL2-HC	58
AB257	Plastic Bolt for SCL2-HC	18	AB326	Compressor Unit Track for SCL2-HC	37	AA379	Temperature Sensor of Cabinet Inside for SCL2-HC	59
AB258	Nut for SCL2-HC	19	AB327	Compressor Unit Installation Board for SCL2-HC	38	AA596	Thermometer for SCL2-HC	60

Parts Breakdown

Model PT-CN-1524-HC 50047

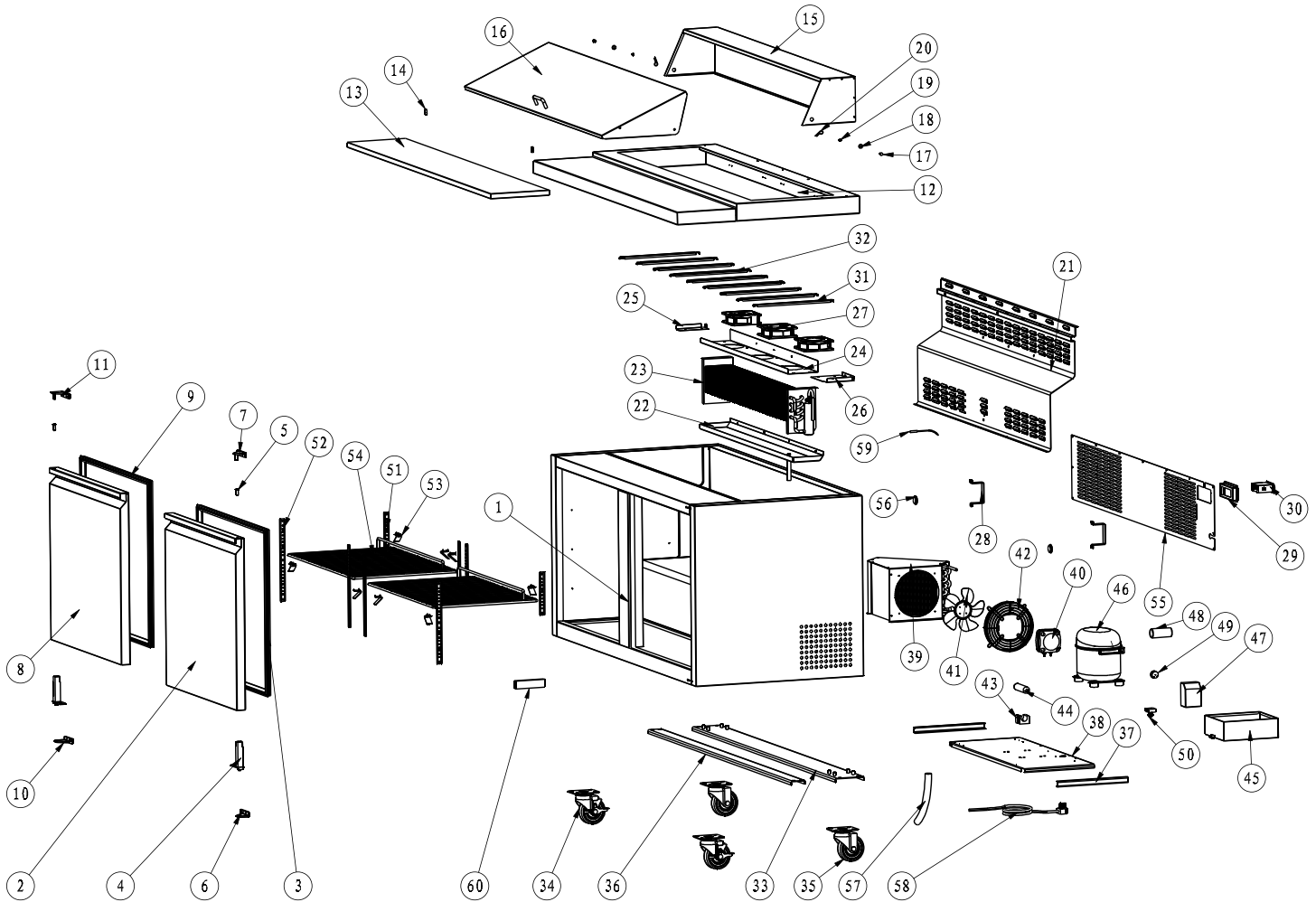

Parts Breakdown

Model PT-CN-1524-HC 50047

Item No.	Description	Position	Item No.	Description	Position	Item No.	Description	Position
AB361	Cabinet for SCL2-60-HC	1	AB259	Split Pin for SCL2-60-HC	20	AB213	Condenser for SCL2-60-HC	39
AB362	Right Door for SCL2-60-HC	2	AB369	Evaporator Cover for SCL2-60-HC	21	AB049	Condenser Fan Motor for SCL2-60-HC	40
AB363	Gasket for SCL2-60-HC	3	AB370	Inner Drain Pan for SCL2-60-HC	22	AA208	Blade of Condenser Fan Motor for SCL2-60-HC	41
AA955	Spring Hinge Board for SCL2-60-HC	4	AA171	Evaporator for SCL2-60-HC	23	AA207	Condenser Fan Cover for SCL2-60-HC	42
AA388	Axis Cover for SCL2-60-HC	5	AB371	Fan Motor Installation Panel for SCL2-60-HC	24	AA129	Filter Fixer for SCL2-60-HC	43
AA360	Bottom Right Hinge for SCL2-60-HC	6	AB372	Left Clapboard of Evaporator for SCL2-60-HC	25	AA371	Filter for SCL2-60-HC	44
AA359	Upper Right Hinge for SCL2-60-HC	7	AB373	Right Clapboard of Evaporator for SCL2-60-HC	26	AB383	Outer Drain Pan for SCL2-60-HC	45
AB364	Left Door for SCL2-60-HC	8	AA128	Evaporator Fan Motor for SCL2-60-HC	27	64168	Compressor for SCL2-60-HC	46
AB363	Gasket for SCL2-60-HC	9	AB374	Stand Off Bracket for SCL2-60-HC	28	AB384	Starter Kit for SCL2-60-HC	47 - 50
61468	Bottom Left Hinge for SCL2-60-HC	10	AB375	Thermostat Installation Board for SCL2-60-HC	29	AB385	K Strip-2 Holes for SCL2-60-HC	51
AB200	Upper Left Hinge for SCL2-60-HC	11	AB376	Thermostat for SCL2-60-HC	30	AB386	K Strip-3 Holes for SCL2-60-HC	52
AB365	Top Board for SCL2-60-HC	12	AB377	Pan Bracket-15 for SCL2-60-HC	31	AB387	K Clip for SCL2-60-HC	53
AB366	Cutting Board for SCL2-60-HC	13	AB378	Pan Bracket-25 for SCL2-60-HC	32	AB388	Shelf for SCL2-60-HC	54
AB253	Fixer for Cutting Board for SCL2-60-HC	14	AB379	Castor Support for SCL2-60-HC	33	AB389	Back Grill for SCL2-60-HC	55
AB367	Back Cover for SCL2-60-HC	15	AA584	4" Castor with Brake for SCL2-60-HC	34	AB169	Foaming Hole Cover for SCL2-60-HC	56
AB368	Lid for SCL2-60-HC	16	AA743	4" Castor for SCL2-60-HC	35	AB133	Drain Hose for SCL2-60-HC	57
AB256	Dowel for SCL2-60-HC	17	AB380	Assembling Panel Support for SCL2-60-HC	36	AA135	Power Cord for SCL2-60-HC	58
AB257	Plastic Bolt for SCL2-60-HC	18	AB381	Compressor Unit Track for SCL2-60-HC	37	AA379	Temperature Sensor of Cabinet Inside for SCL2-60-HC	59
AB258	Nut for SCL2-60-HC	19	AB382	Compressor Unit Installation Board for SCL2-60-HC	38	AA596	Thermometer for SCL2-60-HC	60

Parts Breakdown

Model PT-CN-1778-HC 50048

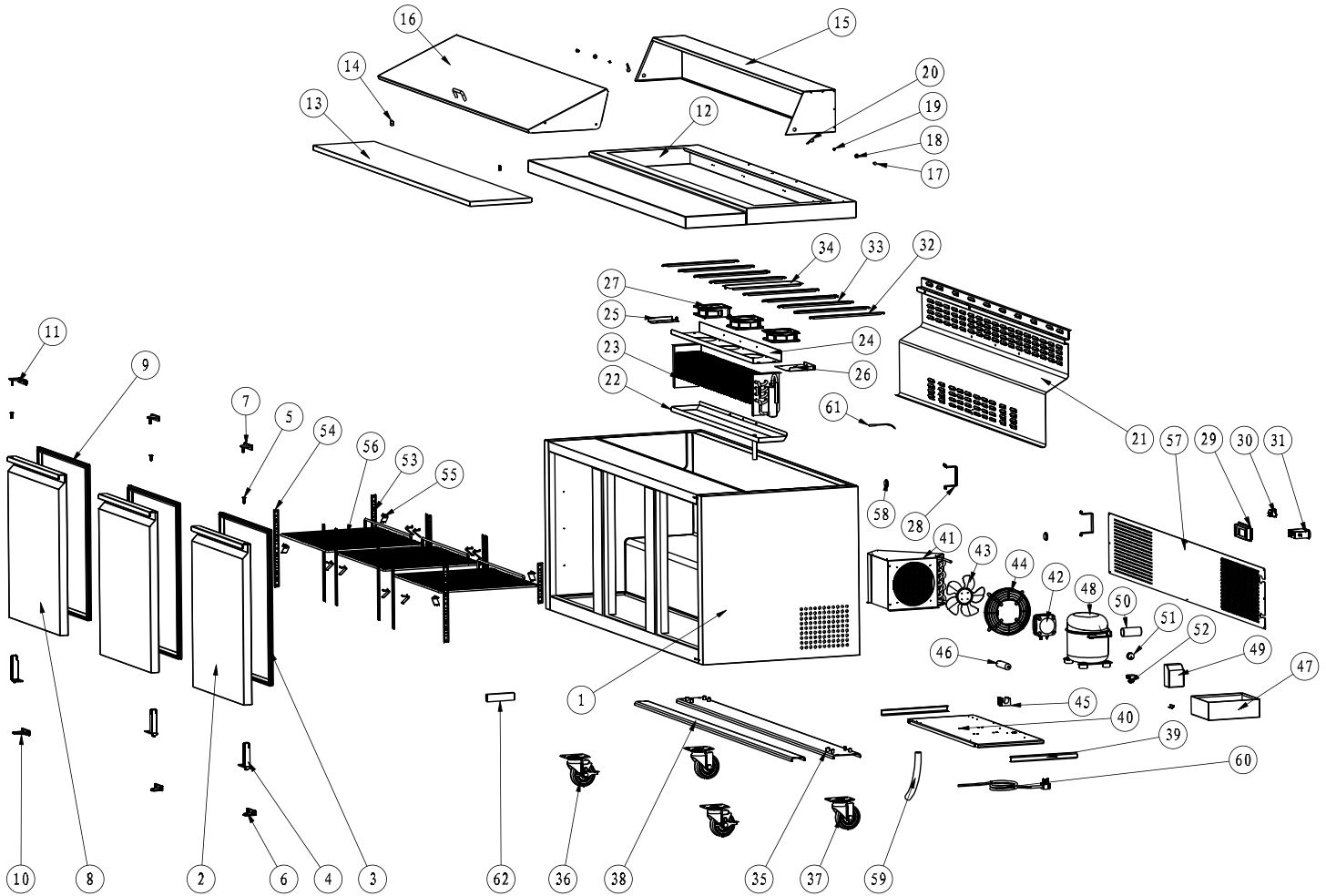

Parts Breakdown

Model PT-CN-1778-HC 50048

Item No.	Description	Position	Item No.	Description	Position	Item No.	Description	Position
AB433	Cabinet for SCL3-HC	1	AB440	Evaporator Cover for SCL3-HC	21	AB213	Condenser for SCL3-HC	41
AB434	Right Door for SCL3-HC	2	AB441	Inner Drain Pan for SCL3-HC	22	AB049	Condenser Fan Motor for SCL3-HC	42
AB197	Gasket for SCL3-HC	3	AA171	Evaporator for SCL3-HC	23	AA208	Blade of Condenser Fan Motor for SCL3-HC	43
AA955	Spring Hinge Board for SCL3-HC	4	AB442	Fan Motor Installation Panel for SCL3-HC	24	AA207	Condenser Fan Cover for SCL3-HC	44
AA388	Axis Cover for SCL3-HC	5	AB443	Left Clapboard of Evaporator for SCL3-HC	25	AA129	Filter Fixer for SCL3-HC	45
AA360	Bottom Right Hinge for SCL3-HC	6	AB444	Right Clapboard of Evaporator for SCL3-HC	26	AA371	Filter for SCL3-HC	46
AA359	Upper Right Hinge for SCL3-HC	7	AA128	Evaporator Fan Motor for SCL3-HC	27	AB455	Outer Drain Pan for SCL3-HC	47
AB435	Left Door for SCL3-HC	8	AB445	Stand Off Bracket for SCL3-HC	28	64170	Compressor for SCL3-HC	48
AB363	Gasket for SCL3-HC	9	AB446	Thermostat Installation Board for SCL3-HC	29	AB456	Starter Kit for SCL3-HC	49 - 52
61468	Bottom Left Hinge for SCL3-HC	10	AA124	Power Switch for SCL3-HC	30	AB457	K Strip-2 Holes for SCL3-HC	53
AB200	Upper Left Hinge for SCL3-HC	11	AB447	Thermostat for SCL3-HC	31	AB458	K Strip-3 Holes for SCL3-HC	54
AB436	Top Board for SCL3-HC	12	AB448	Pan Bracket-15 for SCL3-HC	32	AB459	K Clip for SCL3-HC	55
AB437	Cutting Board for SCL3-HC	13	AB449	Pan Bracket-25 for SCL3-HC	33	AB460	Shelf for SCL3-HC	56
AB253	Fixer for Cutting Board for SCL3-HC	14	AB450	Pan Bracket-90 for SCL3-HC	34	AB461	Back Grill for SCL3-HC	57
AB438	Back Cover for SCL3-HC	15	AB451	Castor Support for SCL3-HC	35	AB169	Foam Hole Cover for SCL3-HC	58
AB439	Lid for SCL3-HC	16	AA584	4" Castor with Brake for SCL3-HC	36	AA133	Drain Hose for SCL3-HC	59
AB256	Dowel for SCL3-HC	17	AA743	4" Castor for SCL3-HC	37	AA135	Power Cord for SCL3-HC	60
AB257	Plastic Bolt for SCL3-HC	18	AB452	Assembling Panel Support for SCL3-HC	38	AA379	Temperature Sensor of Cabinet Inside for SCL3-HC	61
AB258	Nut for SCL3-HC	19	AB453	Compressor Unit Track for SCL3-HC	39	AA596	Thermometer for SCL3-HC	62
AB259	Split Pin for SCL3-HC	20	AB454	Compressor Unit Installation Board for SCL3-HC	40			

Parts Breakdown

Model PT-CN-0711-HC 50049

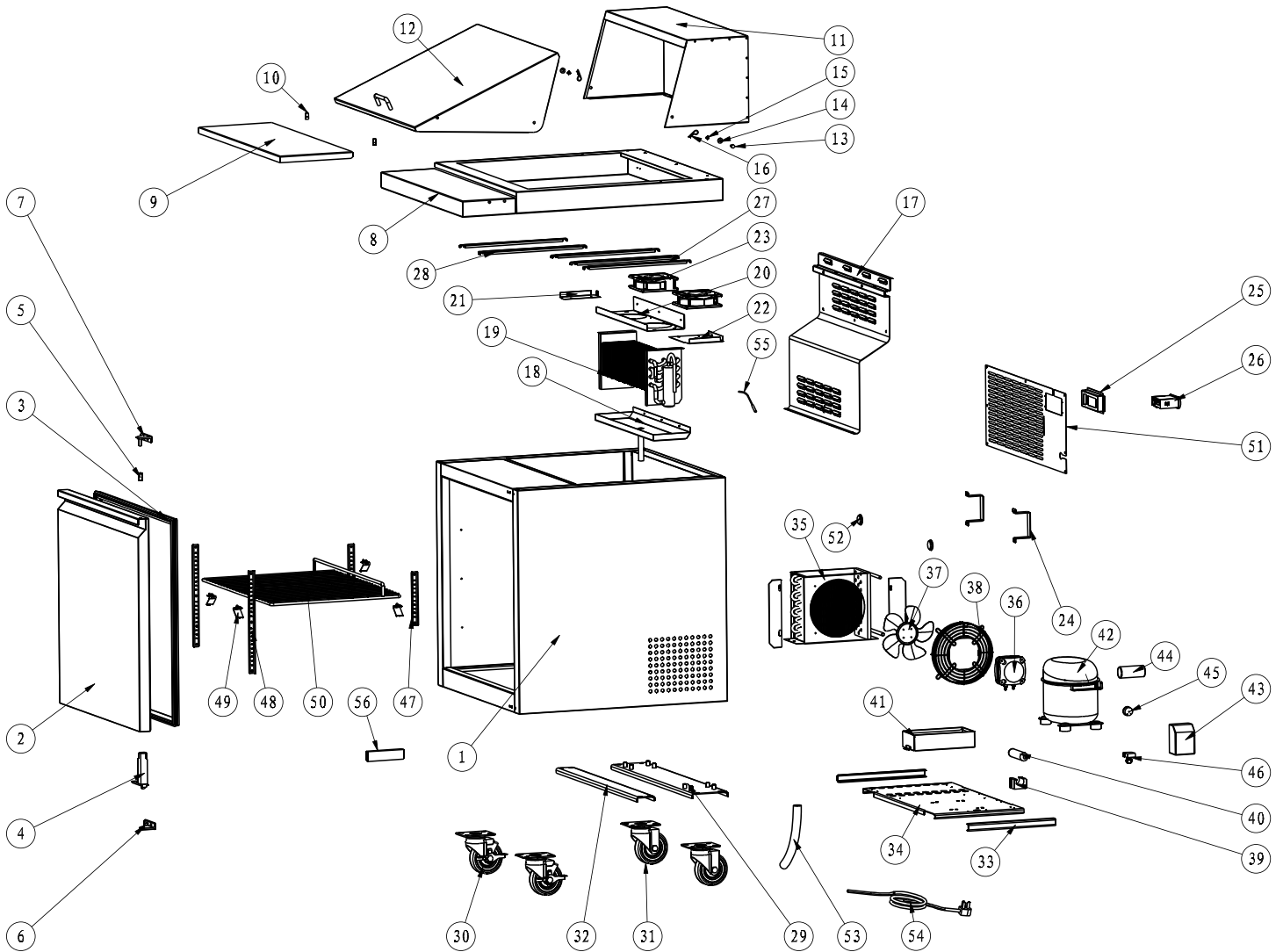

Parts Breakdown

Model PT-CN-0711-HC 50049

Item No.	Description	Position	Item No.	Description	Position	Item No.	Description	Position
AB281	Cabinet for SCLM1-HC	1	AA118	Evaporator for SCLM1-HC	19	AA208	Blade of Condenser Fan Motor for SCLM1-HC	37
AB282	Door for SCLM1-HC	2	AB289	Fan Motor Installation Panel for SCLM1-HC	20	AA207	Condenser Fan Cover for SCLM1-HC	38
AB250	Gasket for SCLM1-HC	3	AB290	Left Clapboard of Evaporator for SCLM1-HC	21	AA129	Filter Fixer for SCLM1-HC	39
AA955	Spring Hinge Board for SCLM1-HC	4	AB291	Right Clapboard of Evaporator for SCLM1-HC	22	AA371	Filter for SCLM1-HC	40
AA388	Axis Cover for SCLM1-HC	5	AA128	Evaporator Fan Motor for SCLM1-HC	23	AB301	Outer Drain Pan for SCLM1-HC	41
AA360	Bottom Right Hinge for SCLM1-HC	6	AB292	Stand Off Bracket for SCLM1-HC	24	64167	Compressor for SCLM1-HC	42
AA359	Upper Right Hinge for SCLM1-HC	7	AB293	Thermostat Installation Board for SCLM1-HC	25	AB302	Starter Kit for SCLM1-HC	43 - 46
AB283	Top Board for SCLM1-HC	8	AB294	Thermostat for SCLM1-HC	26	AB303	K Strip-2 Holes for SCLM1-HC	47
AB284	Cutting Board for SCLM1-HC	9	AB295	Pan Bracket-15 for SCLM1-HC	27	AB304	K Strip-3 Holes for SCLM1-HC	48
AB253	Fixer for Cutting Board for SCLM1-HC	10	AB296	Pan Bracket-25 for SCLM1-HC	28	AB305	K Clip for SCLM1-HC	49
AB285	Back Cover for SCLM1-HC	11	AB297	Castor Support for SCLM1-HC	29	AB279	Shelf for SCLM1-HC	50
AB286	Lid for SCLM1-HC	12	AA584	4" Castor with Brake for SCLM1-HC	30	AB306	Back Grill for SCLM1-HC	51
AB256	Dowel for SCLM1-HC	13	AA743	4" Castor for SCLM1-HC	31	AB169	Foaming Hole Cover for SCLM1-HC	52
AB257	Plastic Bolt for SCLM1-HC	14	AB298	Assembling Panel Support for SCLM1-HC	32	AA133	Drain Hose for SCLM1-HC	53
AB258	Nut for SCLM1-HC	15	AB299	Compressor Unit Track for SCLM1-HC	33	AA135	Power Cord for SCLM1-HC	54
AB259	Split Pin for SCLM1-HC	16	AB300	Compressor Unit Installation Board for SCLM1-HC	34	AA379	Temperature Sensor of Cabinet Inside for SCLM1-HC	55
AB287	Evaporator Cover for SCLM1-HC	17	AB159	Condenser for SCLM1-HC	35	AA596	Thermometer for SCLM1-HC	56
AB288	Inner Drain Pan for SCLM1-HC	18	AA607	Condenser Fan Motor for SCLM1-HC	36			

Parts Breakdown

Model PT-CN-1194-H 50050

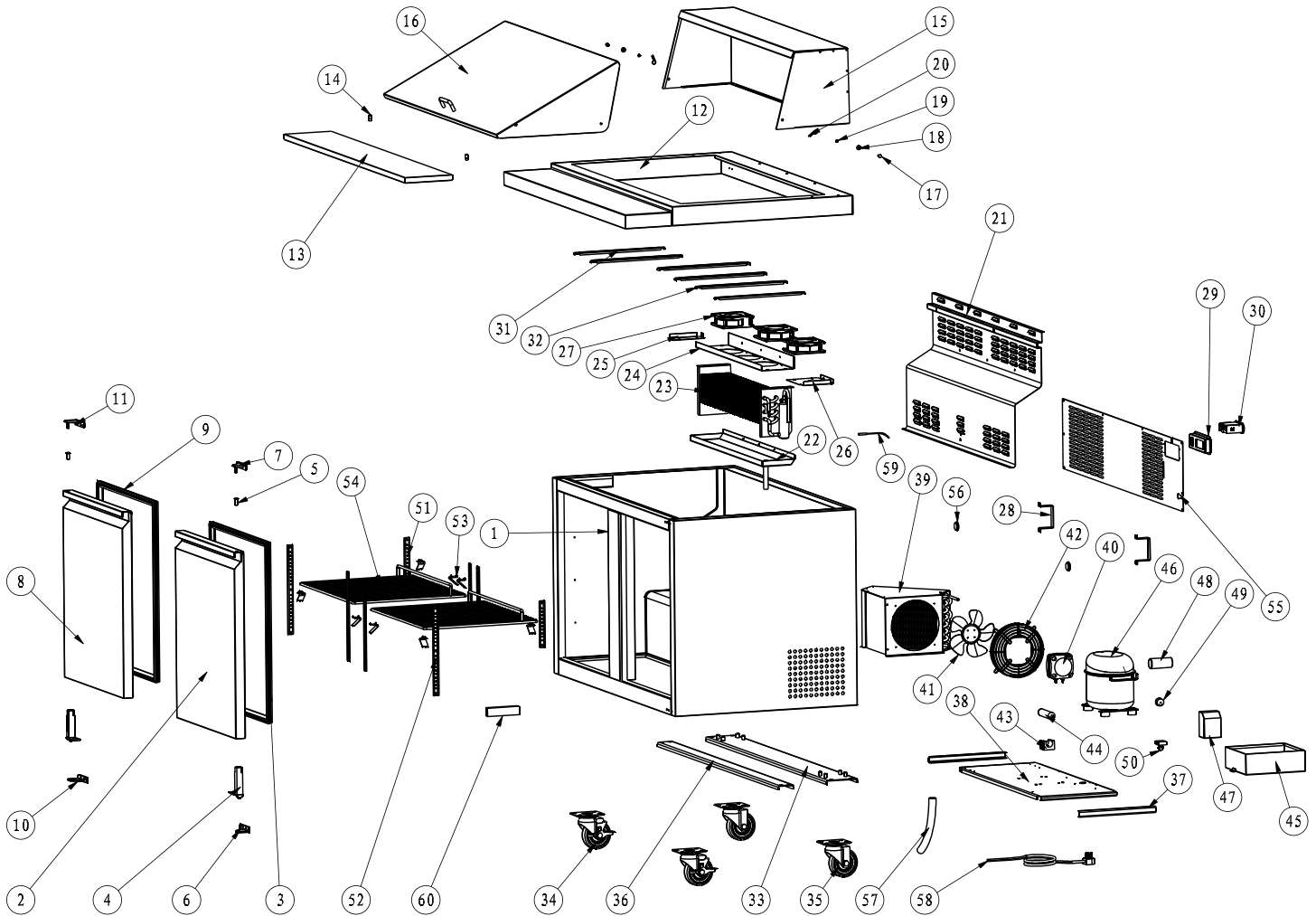

Parts Breakdown

Model PT-CN-1194-H 50050

Item No.	Description	Position	Item No.	Description	Position	Item No.	Description	Position
AB334	Cabinet for SCLM2-HC	1	AB259	Split Pin for SCLM2-HC	20	AB213	Condenser for SCLM2-HC	39
AB335	Right Door for SCLM2-HC	2	AB341	Evaporator Cover for SCLM2-HC	21	AB049	Condenser Fan Motor for SCLM2-HC	40
AB197	Gasket for SCLM2-HC	3	AB342	Inner Drain Pan for SCLM2-HC	22	AA208	Blade of Condenser Fan Motor for SCLM2-HC	41
AA955	Spring Hinge Board for SCLM2-HC	4	AA150	Evaporator for SCLM2-HC	23	AA207	Condenser Fan Cover for SCLM2-HC	42
AA388	Axis Cover for SCLM2-HC	5	AB343	Fan Motor Installation Panel for SCLM2-HC	24	AA129	Filter Fixer for SCLM2-HC	43
AA360	Bottom Right Hinge for SCLM2-HC	6	AB344	Left Clapboard of Evaporator for SCLM2-HC	25	AA371	Filter for SCLM2-HC	44
AA359	Upper Right Hinge for SCLM2-HC	7	AB345	Right Clapboard of Evaporator for SCLM2-HC	26	AB355	Outer Drain Pan for SCLM2-HC	45
AB336	Left Door for SCLM2-HC	8	AA128	Evaporator Fan Motor for SCLM2-HC	27	64168	Compressor for SCLM2-HC	46
AB197	Gasket for SCLM2-HC	9	AB346	Stand Off Bracket for SCLM2-HC	28	AB356	Starter Kit for SCLM2-HC	47 - 50
61468	Bottom Left Hinge for SCLM2-HC	10	AB347	Thermostat Installation Board for SCLM2-HC	29	AB357	K Strip-2 Holes for SCLM2-HC	51
AB200	Upper Left Hinge for SCLM2-HC	11	AB348	Thermostat for SCLM2-HC	30	AB358	K Strip-3 Holes for SCLM2-HC	52
AB337	Top Board for SCLM2-HC	12	AB349	Pan Bracket-15 for SCLM2-HC	31	AB359	K Clip for SCLM2-HC	53
AB338	Cutting Board for SCLM2-HC	13	AB350	Pan Bracket-25 for SCLM2-HC	32	AB220	Shelf for SCLM2-HC	54
AB253	Fixer for Cutting Board for SCLM2-HC	14	AB351	Castor Support for SCLM2-HC	33	AB360	Back Grill for SCLM2-HC	55
AB339	Back Cover for SCLM2-HC	15	AA584	4" Castor with Brake for SCLM2-HC	34	AB169	Foaming Hole Cover for SCLM2-HC	56
AB340	Lid for SCLM2-HC	16	AA743	4" Castor for SCLM2-HC	35	AA133	Drain Hose for SCLM2-HC	57
AB256	Dowel for SCLM2-HC	17	AB352	Assembling Panel Support for SCLM2-HC	36	AA135	Power Cord for SCLM2-HC	58
AB257	Plastic Bolt for SCLM2-HC	18	AB353	Compressor Unit Track for SCLM2-HC	37	AA379	Temperature Sensor of Cabinet Inside for SCLM2-HC	59
AB258	Nut for SCLM2-HC	19	AB354	Compressor Unit Installation Board for SCLM2-HC	38	AA596	Thermometer for SCLM2-HC	60

Parts Breakdown

Model PT-CN-1537-HC 50051

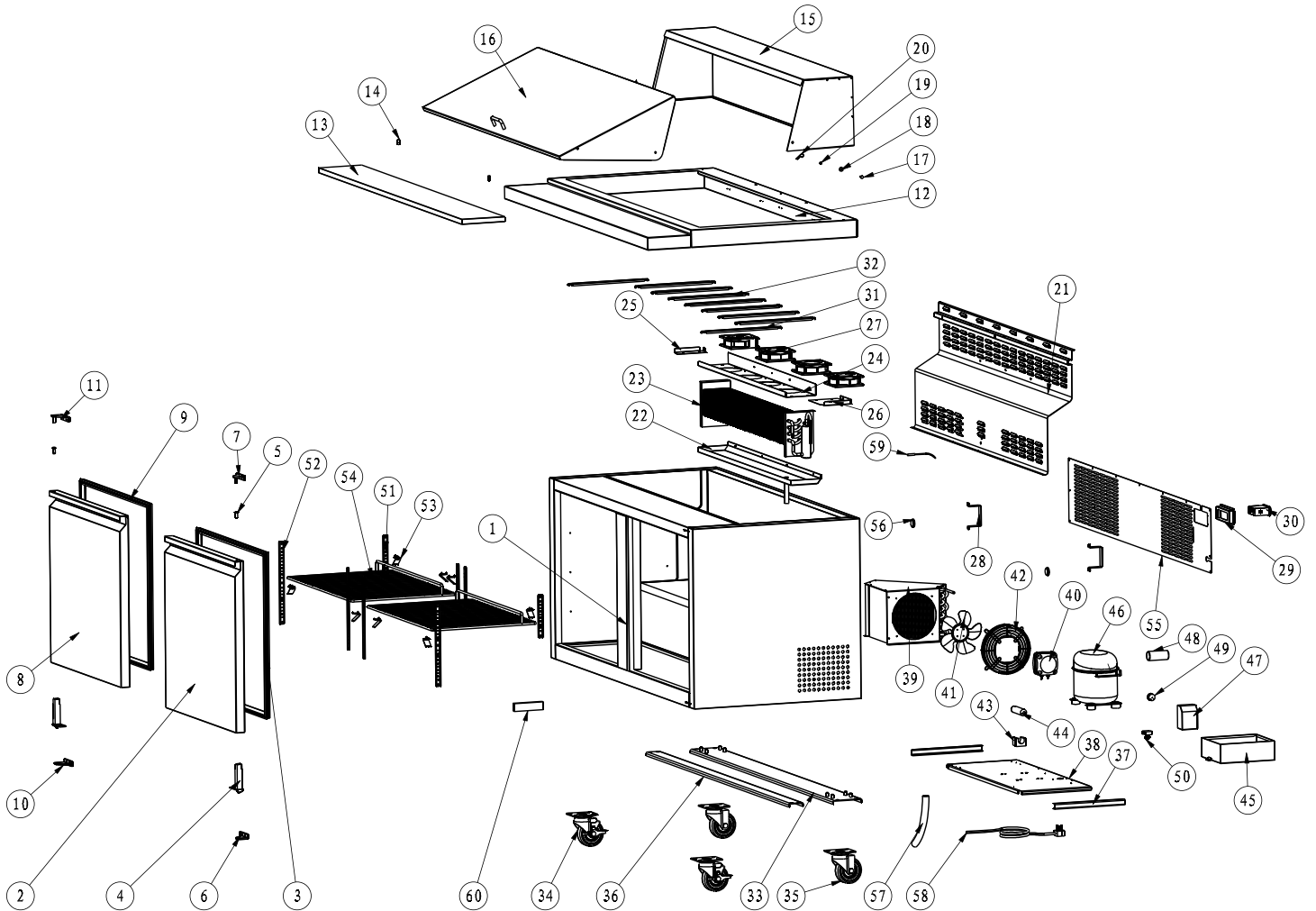

Parts Breakdown

Model PT-CN-1537-HC 50051

Item No.	Description	Position	Item No.	Description	Position	Item No.	Description	Position
AB406	Cabinet for SCLM2-60-HC	1	AB259	Split Pin for SCLM2-60-HC	20	AB213	Condenser for SCLM2-60-HC	39
AB407	Right Door for SCLM2-60-HC	2	AB413	Evaporator Cover for SCLM2-60-HC	21	AB049	Condenser Fan Motor for SCLM2-60-HC	40
AB363	Gasket for SCLM2-60-HC	3	AB414	Inner Drain Pan for SCLM2-60-HC	22	AA208	Blade of Condenser Fan Motor for SCLM2-60-HC	41
AA955	Spring Hinge Board for SCLM2-60-HC	4	AA171	Evaporator for SCLM2-60-HC	23	AA207	Condenser Fan Cover for SCLM2-60-HC	42
AA388	Axis Cover for SCLM2-60-HC	5	AB415	Fan Motor Installation Panel for SCLM2-60-HC	24	AA129	Filter Fixer for SCLM2-60-HC	43
AA360	Bottom Right Hinge for SCLM2-60-HC	6	AB416	Left Clapboard of Evaporator for SCLM2-60-HC	25	AA371	Filter for SCLM2-60-HC	44
AA359	Upper Right Hinge for SCLM2-60-HC	7	AB417	Right Clapboard of Evaporator for SCLM2-60-HC	26	AB427	Outer Drain Pan for SCLM2-60-HC	45
AB408	Left Door for SCLM2-60-HC	8	AA128	Evaporator Fan Motor for SCLM2-60-HC	27	64168	Compressor for SCLM2-60-HC	46
AB363	Gasket for SCLM2-60-HC	9	AB418	Stand Off Bracket for SCLM2-60-HC	28	AB428	Starter Kit for SCLM2-60-HC	47 - 50
61468	Bottom Left Hinge for SCLM2-60-HC	10	AB419	Thermostat Installation Board for SCLM2-60-HC	29	AB429	K Strip-2 Holes for SCLM2-60-HC	51
AB200	Upper Left Hinge for SCLM2-60-HC	11	AB420	Thermostat for SCLM2-60-HC	30	AB430	K Strip-3 Holes for SCLM2-60-HC	52
AB409	Top Board for SCLM2-60-HC	12	AB421	Pan Bracket-15 for SCLM2-60-HC	31	AB431	K Clip for SCLM2-60-HC	53
AB410	Cutting Board for SCLM2-60-HC	13	AB422	Pan Bracket-25 for SCLM2-60-HC	32	AB388	Shelf for SCLM2-60-HC	54
AB253	Fixer for Cutting Board for SCLM2-60-HC	14	AB423	Castor Support for SCLM2-60-HC	33	AB432	Back Grill for SCLM2-60-HC	55
AB411	Back Cover for SCLM2-60-HC	15	AA584	4" Castor with Brake for SCLM2-60-HC	34	AB169	Foaming Hole Cover for SCLM2-60-HC	56
AB412	Lid for SCLM2-60-HC	16	AA743	4" Castor for SCLM2-60-HC	35	AA133	Drain Hose for SCLM2-60-HC	57
AB256	Dowel for SCLM2-60-HC	17	AB424	Assembling Panel Support for SCLM2-60-HC	36	AA135	Power Cord for SCLM2-60-HC	58
AB257	Plastic Bolt for SCLM2-60-HC	18	AB425	Compressor Unit Track for SCLM2-60-HC	37	AA379	Temperature Sensor of Cabinet Inside for SCLM2-60-HC	59
AB258	Nut for SCLM2-60-HC	19	AB426	Compressor Unit Installation Board for SCLM2-60-HC	38	AA596	Thermometer for SCLM2-60-HC	60

Electrical Schematics

Model PT-CN-0686-HC 50045

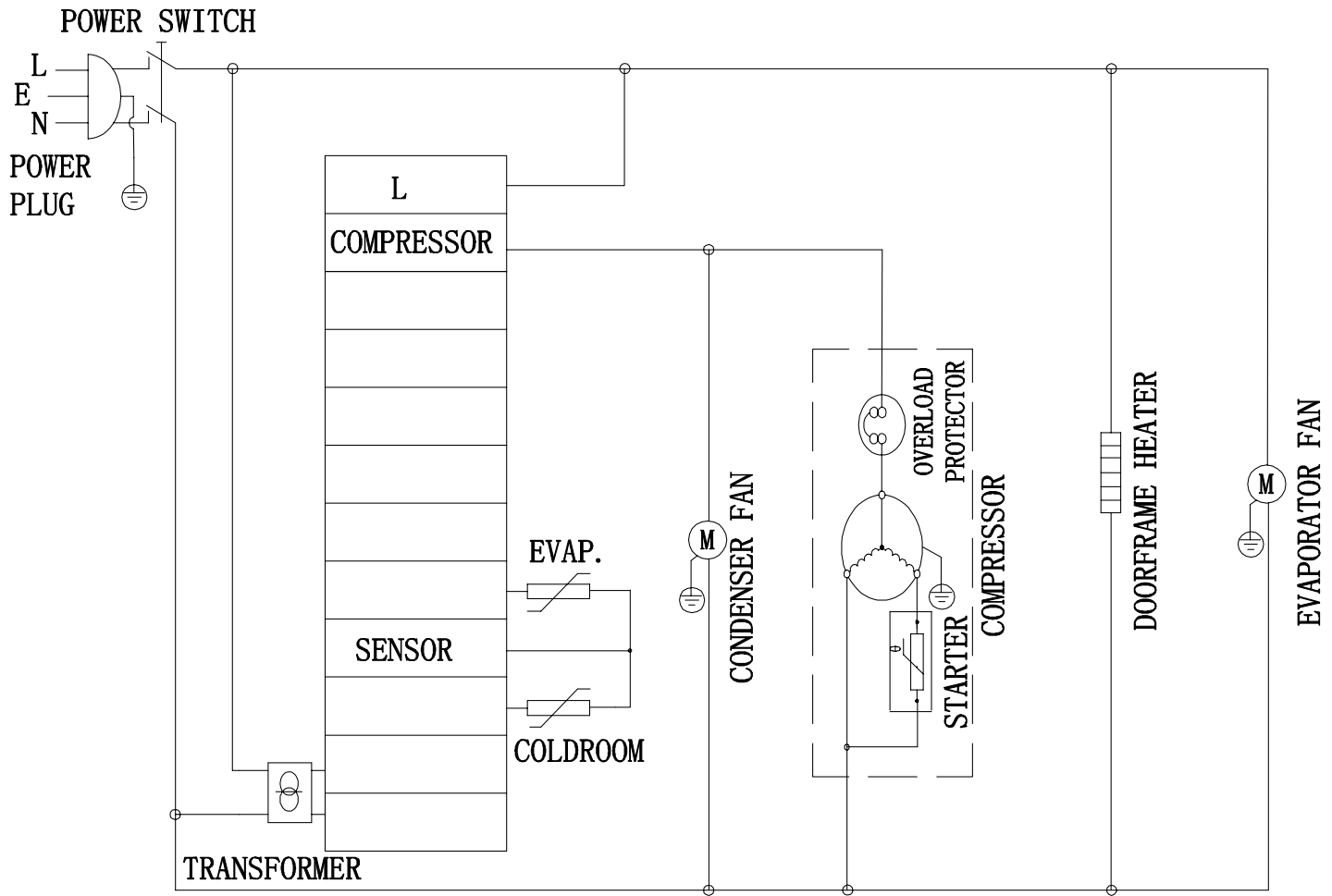

Electrical Schematics

Model PT-CN-1194-HC 50046

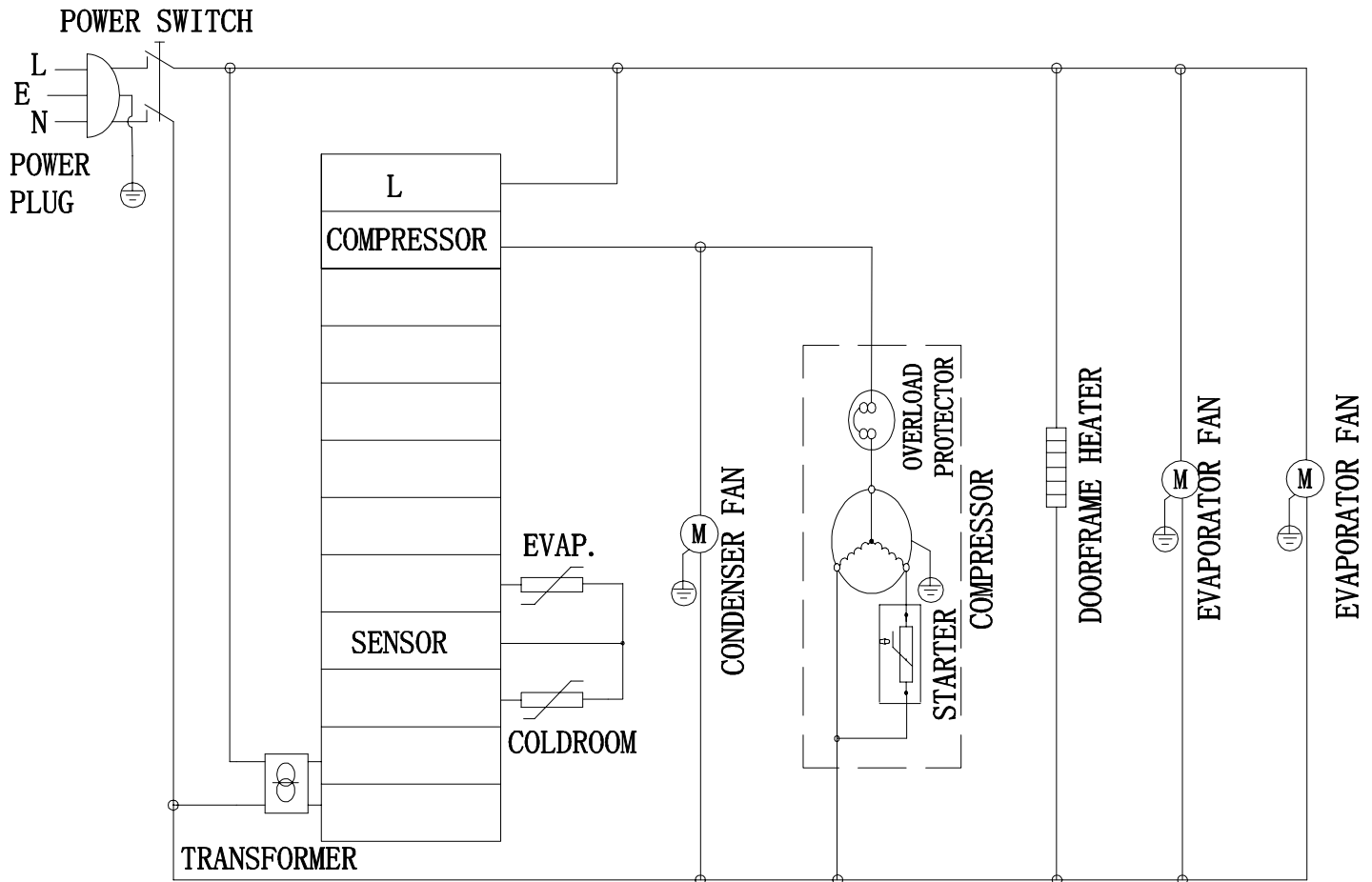

Electrical Schematics

Model PT-CN-1524-HC 50047

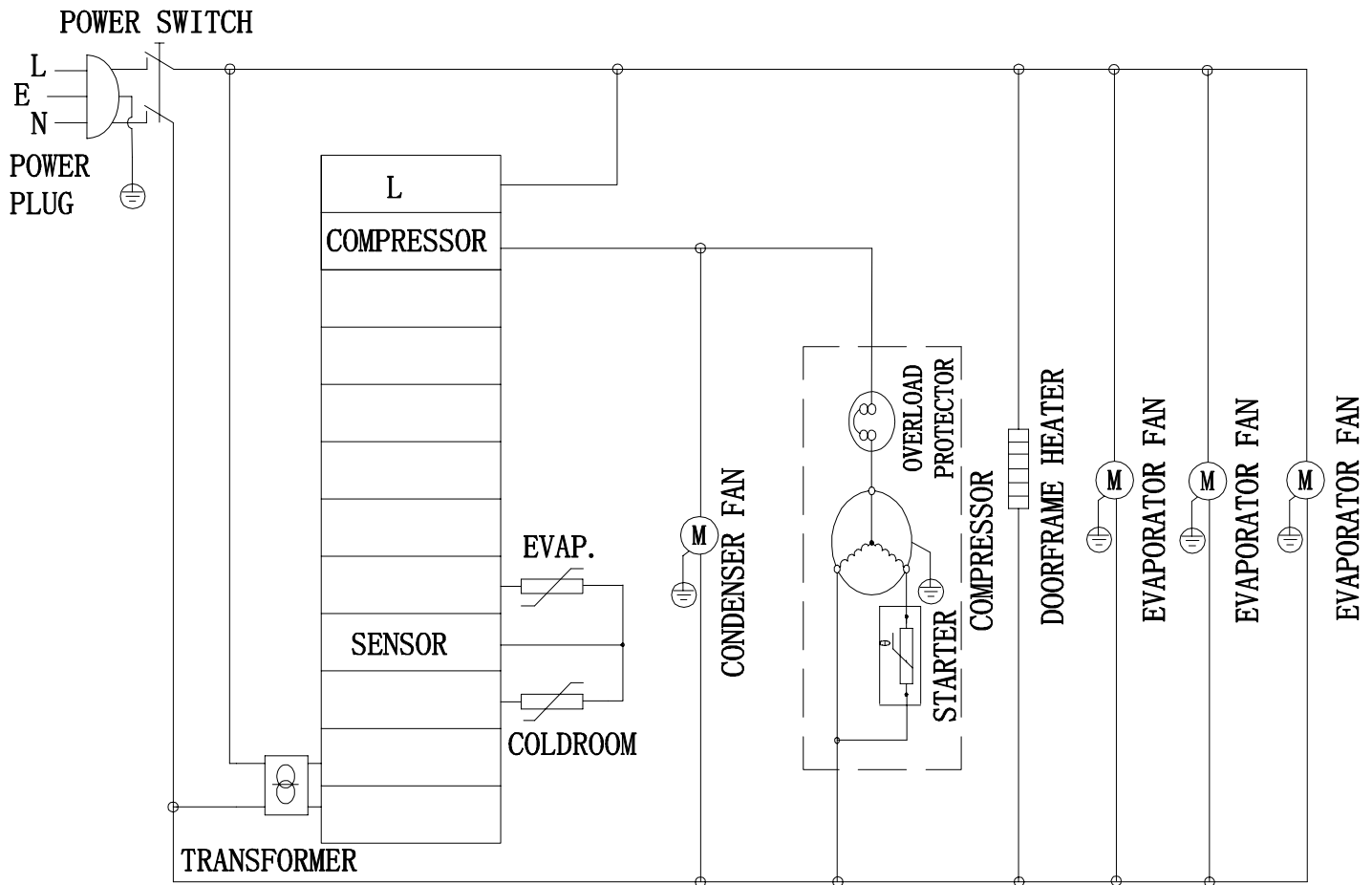

Electrical Schematics

Model PT-CN-1778-HC 50048

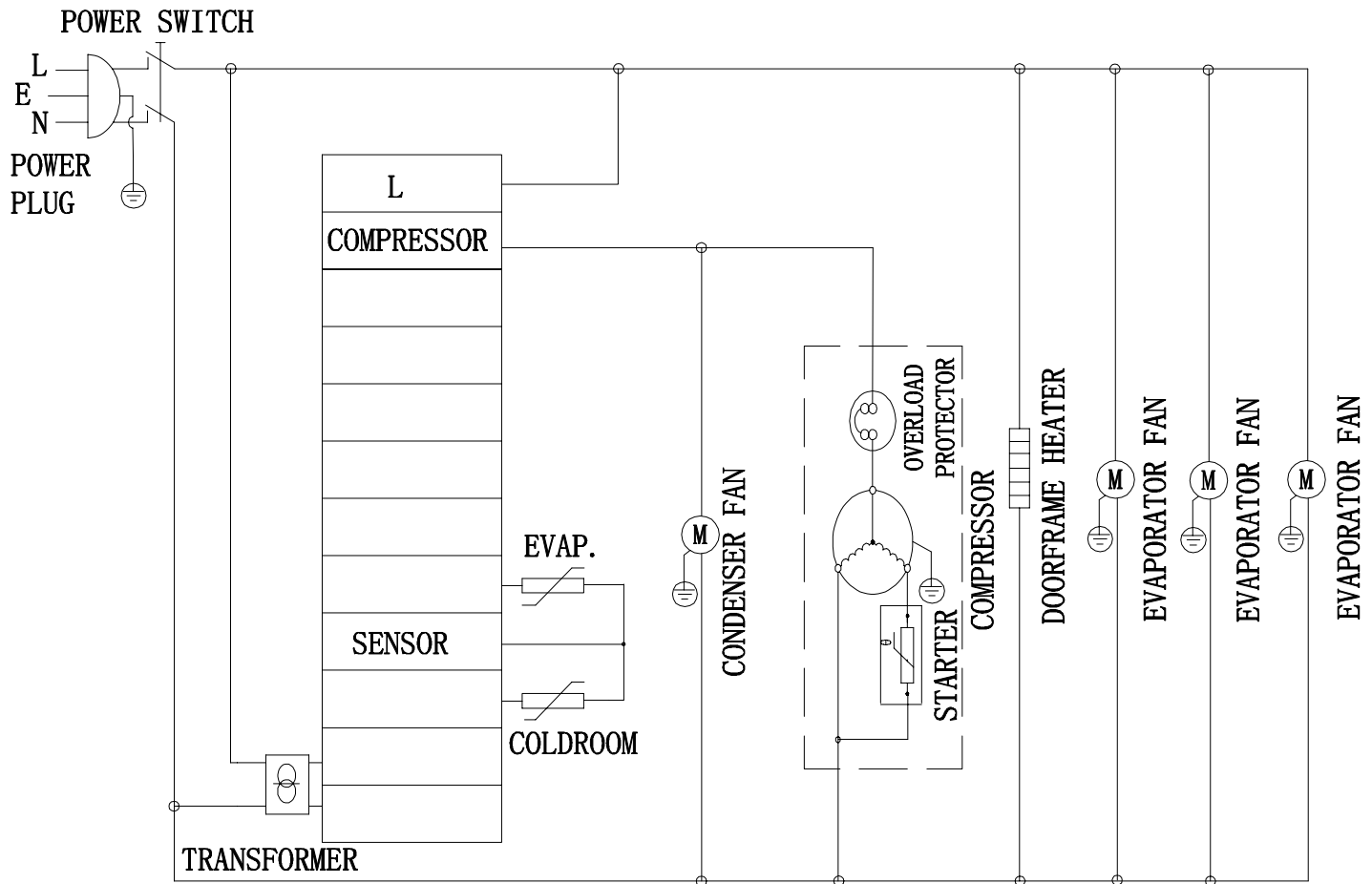

Electrical Schematics

Model **PT-CN-0711-HC** 50049

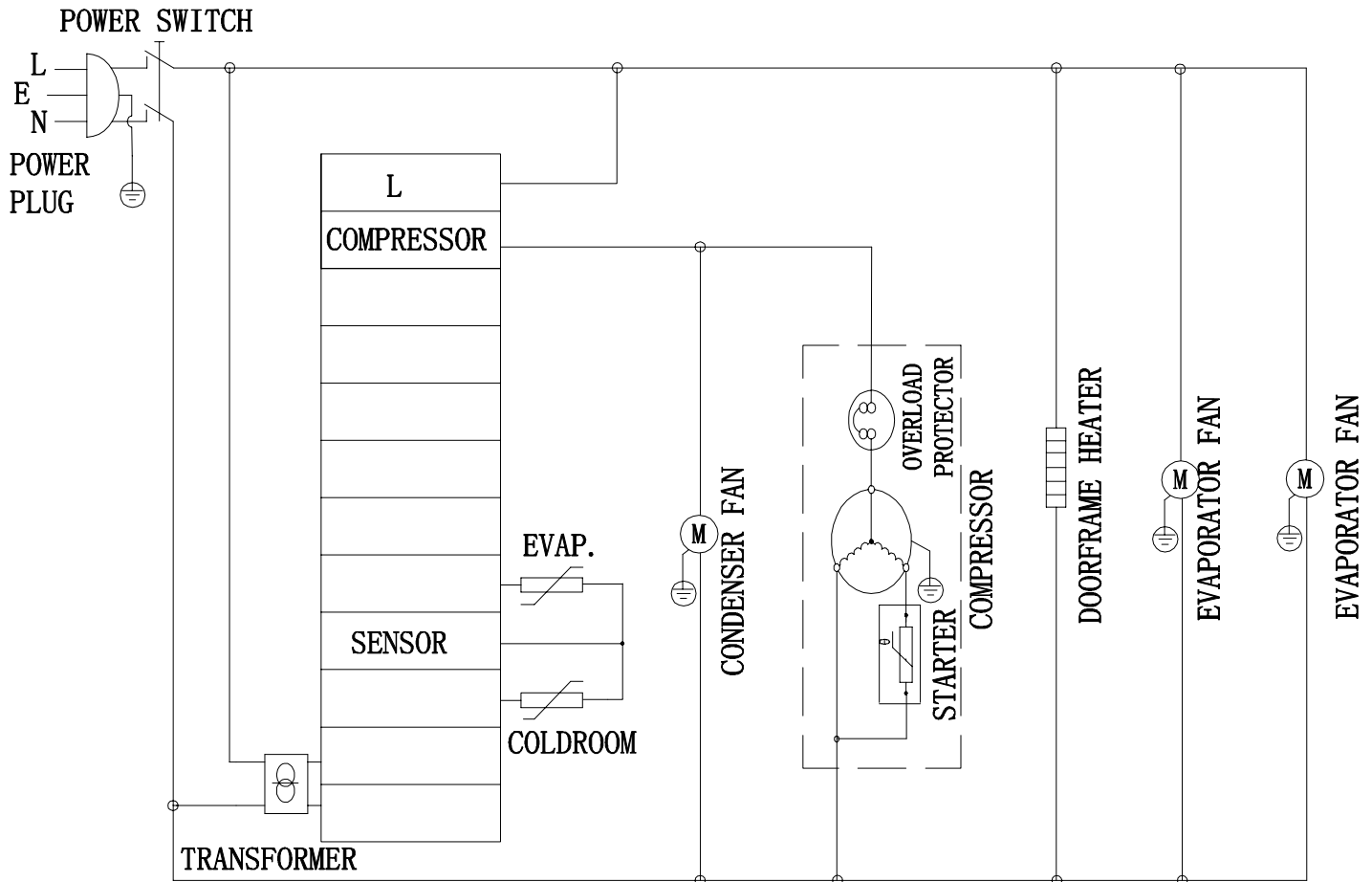

Electrical Schematics

Model PT-CN-1194-H 50050

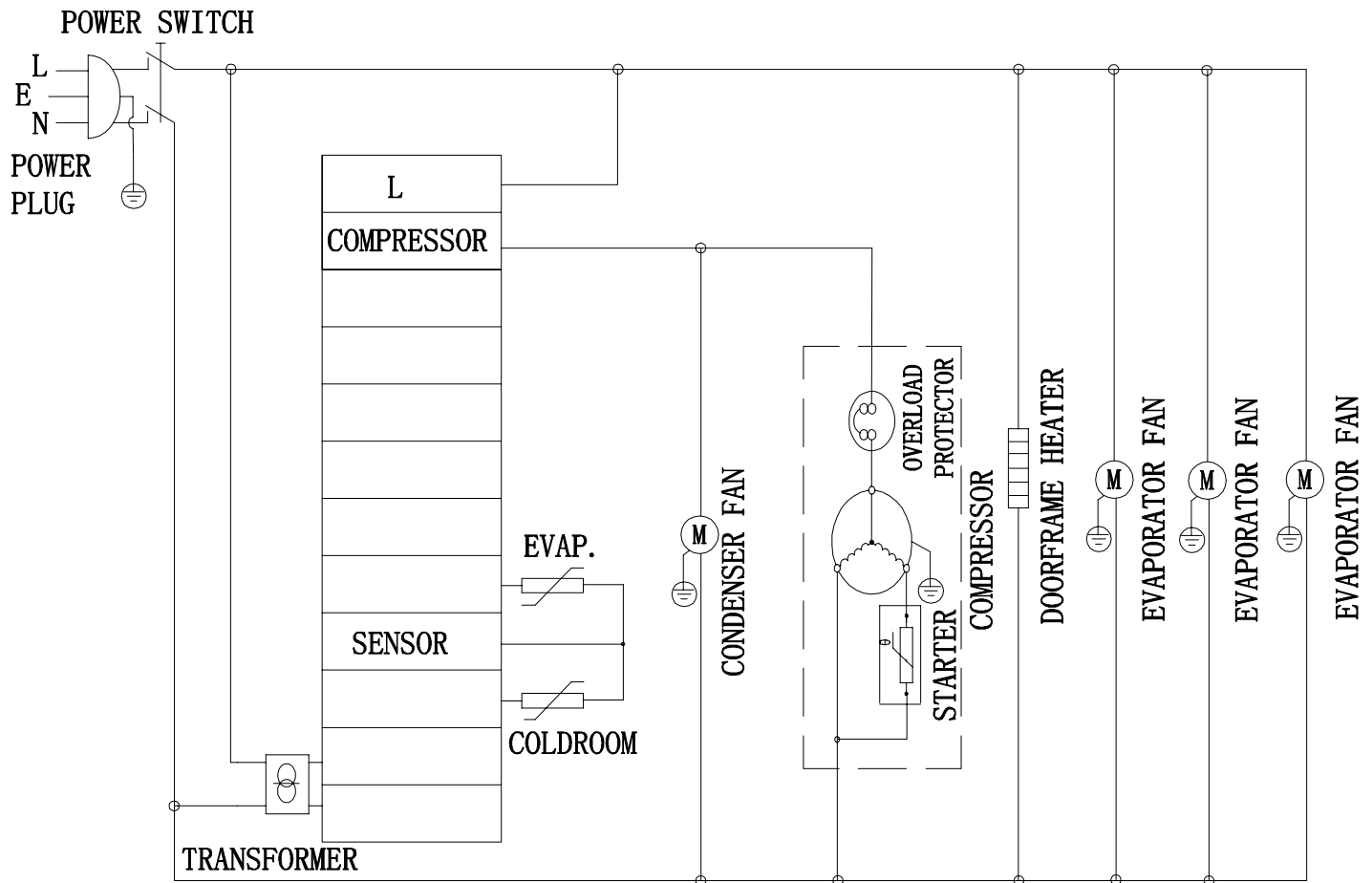

Electrical Schematics

Model PT-CN-1537-HC 50051

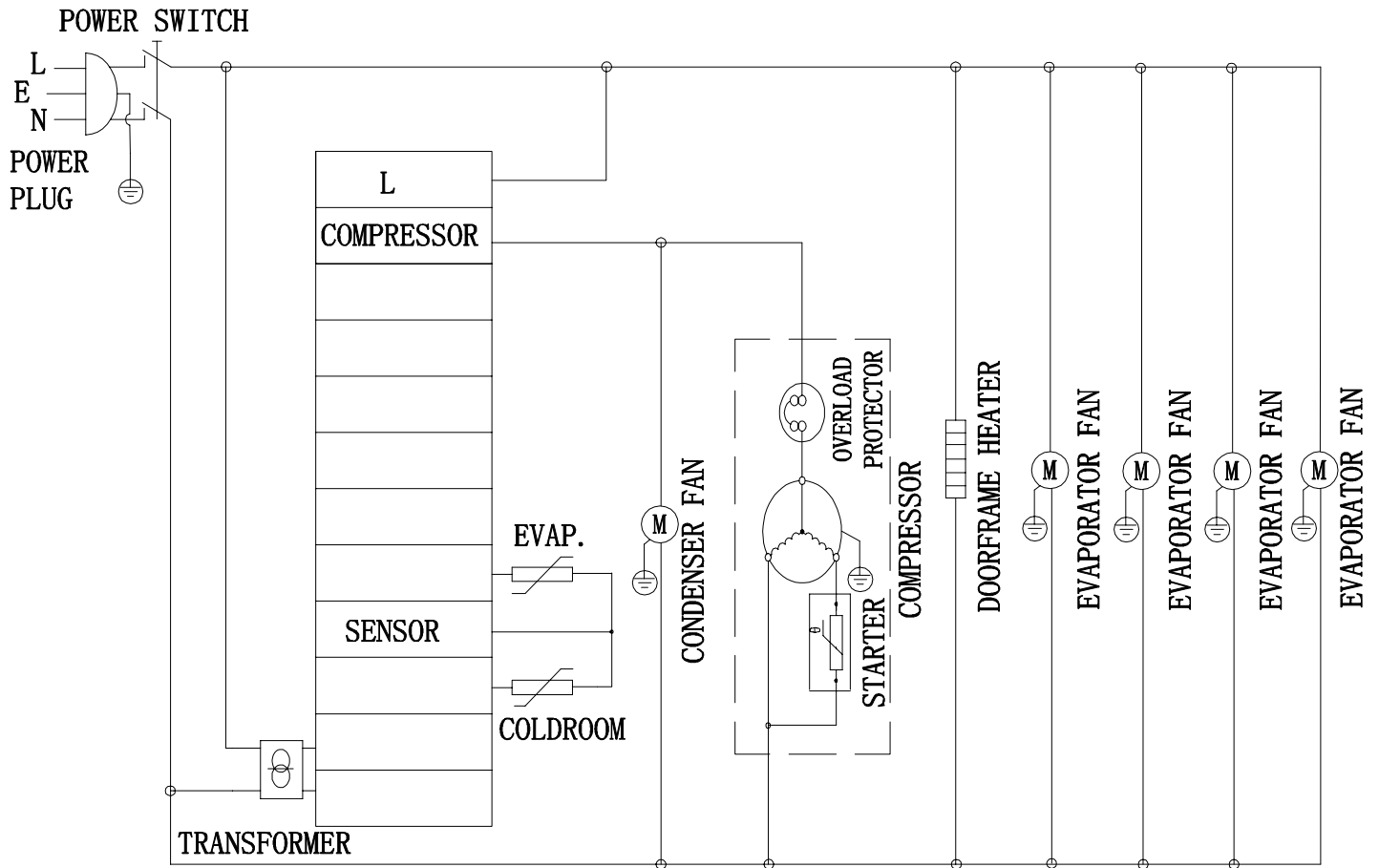



Warranty Registration

Thank you for purchasing an Omcan product. To register your warranty for this product, complete the information below, tear off the card at the perforation and then send to the address specified below. You can also register online by visiting:

Merci d'avoir acheté un produit Omcan. Pour enregistrer votre garantie pour ce produit, complétez les informations ci-dessous, détachez la carte au niveau de la perforation, puis l'envoyer à l'adresse spécifiée ci-dessous. Vous pouvez également vous inscrire en ligne en visitant:

Gracias por comprar un producto Omcan usted. Para registrar su garantía para este producto, complete la información a continuación, cortar la tarjeta en la perforación y luego enviarlo a la dirección indicada a continuación. También puede registrarse en línea en:

<https://omcan.com/warranty-registration/>

For mailing in Canada

Pour postale au Canada

Por correo en Canadá

OMCAN

PRODUCT WARRANTY REGISTRATION

3115 Pepper Mill Court,

Mississauga, Ontario

Canada, L5L 4X5

For mailing in the US

Pour diffusion aux États-Unis

Por correo en los EE.UU.

OMCAN

PRODUCT WARRANTY REGISTRATION

4450 Witmer Industrial Estates, Unit 4,

Niagara Falls, New York

USA, 14305

or email to: service@omcan.com



Purchaser's Information

Name: _____

Address: _____

City: _____ Province or State: _____ Postal or Zip: _____

Country: _____

Dealer from which Purchased: _____

Dealer City: _____ Dealer Province or State: _____

Invoice: _____

Model Name: _____ Model Number: _____

Machine Description: _____

Date of Purchase (MM/DD/YYYY): _____

Would you like to extend the warranty? Yes No

Company Name: _____

Telephone: _____

Email Address: _____

Type of Company:

Restaurant Bakery Deli

Butcher Supermarket Caterer

Institution (specify): _____

Other (specify): _____

Serial Number: _____

Date of Installation (MM/DD/YYYY): _____

Thank you for choosing Omcan | Merci d'avoir choisi Omcan | Gracias por elegir Omcan



Since 1951 Omcan has grown to become a leading distributor of equipment and supplies to the North American food service industry. Our success over these many years can be attributed to our commitment to strengthen and develop new and existing relationships with our valued customers and manufacturers. Today with partners in North America, Europe, Asia and South America, we continually work to improve and grow the company. We strive to offer customers exceptional value through our qualified local sales and service representatives who provide convenient access to over 5,000 globally sourced products.

Depuis 1951 Omcan a grandi pour devenir un des “leaders” de la distribution des équipements et matériel pour l’industrie des services alimentaires en Amérique du Nord. Notre succès au cours de ces nombreuses années peut être attribué à notre engagement à renforcer et à développer de nouvelles et existantes relations avec nos clients et les fabricants de valeur. Aujourd’hui avec des partenaires en Amérique du Nord, Europe, Asie et Amérique du Sud, nous travaillons continuellement à améliorer et développer l’entreprise. Nous nous efforçons d’offrir à nos clients une valeur exceptionnelle grâce à nos ventes locales qualifiées et des représentants de service qui offrent un accès facile à plus de 5000 produits provenant du monde entier.

Desde 1951 Omcan ha crecido hasta convertirse en un líder en la distribución de equipos y suministros de alimentos en América del Norte industria de servicios. Nuestro éxito en estos años se puede atribuir a nuestro compromiso de fortalecer y desarrollar nuevas relaciones existentes con nuestros valiosos clientes y fabricantes. Hoy con socios de América del Norte, Europa, Asia y América del Sur, que trabajan continuamente para mejorar y crecer la empresa. Nos esforzamos por ofrecer a nuestros clientes valor excepcional a través de nuestro local de ventas y representantes de los servicios que proporcionan un fácil acceso a más de 5,000 productos con origen a nivel mundial.

