



**Refrigerated Showcase**  
**Model RS-CN-0360**  
**Item 41465**  
**Instruction Manual**



*Revised - 12/03/2019*



Toll Free: 1-800-465-0234  
Fax: 905-607-0234  
Email: [service@omcan.com](mailto:service@omcan.com)  
[www.omcan.com](http://www.omcan.com)

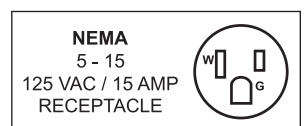

# ***Table of Contents***

Model RS-CN-0360

---

<b>Section</b>	<b>Page</b>
General Information -----	3 - 4
Safety and Warranty -----	4 - 6
Technical Specifications -----	6
Operation -----	7
Maintenance -----	7 - 8
Troubleshooting -----	8 - 9
Parts Breakdown -----	10 - 12
Electrical Schematics -----	13
Notes -----	14
Warranty Registration -----	15



# General Information

---

Omcan Manufacturing and Distributing Company Inc., Food Machinery of America, Inc. dba Omcan and Omcan Inc. are not responsible for any harm or injury caused due to any person's improper or negligent use of this equipment. The product shall only be operated by someone over the age of 18, of sound mind, and not under the influence of any drugs or alcohol, who has been trained in the correct operation of this machine, and is wearing authorized, proper safety clothing. Any modification to the machine voids any warranty, and may cause harm to individuals using the machine or in the vicinity of the machine while in operation.

## CHECK PACKAGE UPON ARRIVAL

Upon receipt of an Omcan shipment please inspect for external damage. If no damage is evident on the external packaging, open carton to ensure all ordered items are within the box, and there is no concealed damage to the machine. If the package has suffered rough handling, bumps or damage (visible or concealed), please note it on the bill of lading before accepting the delivery and contact Omcan within 24 hours, so we may initiate a claim with the carrier. A detailed report on the extent of the damage caused to the machine must be filled out within three days, from the delivery date shown in the shipping documents. Omcan has no recourse for damaged products that were shipped collect or third party.

**Before operating any equipment, always read and familiarize yourself with all operation and safety instructions.**

Omcan would like to thank you for purchasing this machine. It's of the utmost importance to save these instructions for future reference. Also save the original box and packaging for shipping the equipment if servicing or returning of the machine is required.

---

Omcan Fabrication et distribution Compañie Limité et Food Machinery d'Amérique, dba Omcan et Omcan Inc. ne sont pas responsables de tout dommage ou blessure causé du fait que toute personne ait utilisé cet équipement de façon irrégulière. Le produit ne doit être exploité que par quelqu'un de plus de 18 ans, saine d'esprit, et pas sous l'influence d'une drogue ou d'alcool, qui a été formé pour utiliser cette machine correctement, et est vêtu de vêtements de sécurité approprié. Toute modification de la machine annule toute garantie, et peut causer un préjudice à des personnes utilisant la machine ou des personnes à proximité de la machine pendant son fonctionnement.

## VÉRIFIEZ LE COLIS DÈS RÉCEPTION

Dès réception d'une expédition d'Omcan veuillez inspecter pour dommages externes. Si aucun dommage n'est visible sur l'emballage externe, ouvrez le carton afin de s'assurer que tous les éléments commandés sont dans la boîte, et il n'y a aucun dommage dissimulé à la machine. Si le colis n'a subi aucune mauvaises manipulations, de bosses ou de dommages (visible ou cachée), notez-le sur le bond de livraison avant d'accepter la livraison et contactez Omcan dans les 24 heures qui suivent, pour que nous puissions engager une réclamation auprès du transporteur. Un rapport détaillé sur l'étendue des dommages causés à la machine doit être rempli dans un délai de trois jours, à compter de la date de livraison indiquée dans les documents d'expédition. Omcan n'a aucun droit de recours pour les produits endommagés qui ont été expédiés ou cueilli par un tiers transporteur.

# General Information

---

Avant d'utiliser n'importe quel équipement, toujours lire et vous familiariser avec toutes les opérations et les consignes de sécurité.

Omcan voudrais vous remercier d'avoir choisi cette machine. Il est primordial de conserver ces instructions pour une référence ultérieure. Également conservez la boîte originale et l'emballage pour l'expédition de l'équipement si l'entretien ou le retour de la machine est nécessaire.

Omcan Empresa De Fabricacion Y Distribucion Inc. Y Maquinaria De Alimentos De America, Inc. dba Omcan y Omcan Inc. no son responsables de ningun daño o perjuicio causado por cualquier persona inadecuada o el uso descuidado de este equipo. El producto solo podra ser operado por una persona mayor de 18 años, en su sano juicio y no bajo alguna influencia de droga o alcohol, y que este ha sido entrenado en el correcto funcionamiento de esta máquina, y ésta usando ropa apropiada y autorizada. Cualquier modificación a la máquina anula la garantía y puede causar daños a las personas usando la máquina mientras esta en el funcionamiento.

## REVISE EL PAQUETE A SU LLEGADA

Tras la recepcion de un envio Omcan favor inspeccionar daños externos. Si no hay daños evidentes en el empaque exterior, Habra el carton para asegurarse que todos los articulos solicitados estén dentro de la caja y no encuentre daños ocultos en la máquina. Si el paquete ha sufrido un manejo de poco cuidado, golpes o daños (visible o oculto) por favor anote en la factura antes de aceptar la entrega y contacte Omcan dentro de las 24 horas, de modo que podamos iniciar una reclamación con la compañía. Un informe detallado sobre los daños causados a la máquina debe ser llenado en el plazo de tres días, desde la fecha de entrega que se muestra en los documentos de envío. Omcan no tiene ningun recurso por productos dañados que se enviaron a recoger por terceros.

Antes de utilizar cualquier equipo, siempre lea y familiarizarse con todas las instrucciones de funcionamiento y seguridad.

Omcan le gustaría darle las gracias por la compra de esta máquina. Es de la mayor importancia para salvar estas instrucciones para futuras consultas. Además, guarda la caja original y el embalaje para el envío del equipo si servicio técnico o devolución de la máquina que se requiere.

# Safety and Warranty

---

## HANDLING AND INSTALLATION

<b>Handle with care</b> Unplug from the wall socket before moving. Never tilt the refrigerator over 45 degrees during handling.	<b>Storage</b> Always store the refrigerator in a dry place.
--	---



# Safety and Warranty

<b>Sufficient space</b> To allow for proper air circulation and increased refrigeration capabilities, the refrigerator must have at least 4"/10cm of space between wall/ceiling and the machine.	<b>Proper ventilation</b> Always place the refrigerator in an area with good ventilation. For first time use, set in location and wait at least 2 hours before plugging into wall socket.
<b>Away from heat source</b> Never place the refrigerator near any type of heat source or in direct sunlight, as it reduces refrigeration capabilities.	<b>No heavy load</b> Never put heavy items on top of the refrigerator.
<b>No altercations/tampering</b> Never tamper with or make changes to the refrigerator. Changes and add-ons should not be installed to the inside or outside of the refrigerator.	<b>Stable location</b> Unpack and place the refrigerator on flat, solid ground.

## PREPARATION AND POWER SUPPLY

<b>Exclusive power outlet</b> Power supply should be 110V, single phase AC with exclusive single phase three pin outlet (125V/15A). The power outlet must be in close proximity to the ground.	<b>No shared power outlets</b> Refrigerator cable should never share the power outlet with any other appliance, as cable will overheat and may result in a fire.
<b>Protect cables</b> Extra caution should be used when handling cables, as broken or damaged cables can cause sparking and may result in a fire.	<b>No water flushing</b> Never flush the refrigerator surface. This can cause leakage, which may result in electrical damage or fire.
<b>Never store flammables and explosives</b> No explosives or flammables should be stored in, or in proximity to, the refrigerator, such as gasoline, alcohol, and adhesives.	<b>No spray</b> Never spray flammables such as paint or coating near the refrigerator. This may cause fire or malfunction.
<b>After power outage</b> After a power outage or the unplugging of the refrigerator, wait at least 5 minutes before plugging it back in.	<b>No medicine</b> Medicine should not be stored inside of the refrigerator.

## 1 YEAR PARTS AND LABOUR WARRANTY

Within the warranty period, contact Omcan Inc. at 1-800-465-0234 to schedule an Omcan authorized service technician to repair the equipment locally.

Unauthorized maintenance will void the warranty. Warranty covers electrical and part failures not improper use.

Please see <https://omcan.com/disclaimer> for complete info.

# Safety and Warranty

---

## WARNING:

The packaging components are classified as normal solid urban waste and can therefore be disposed of without difficulty.

In any case, for suitable recycling, we suggest disposing of the products separately (differentiated waste) according to the current norms.

**DO NOT DISCARD ANY PACKAGING MATERIALS IN THE ENVIRONMENT!**

# Technical Specifications

---

<b>Model</b>	<b>RS-CN-0360</b>
<b>Rated Input Power</b>	1260 W
<b>Electrical Heating Element</b>	400 W
<b>Capacity</b>	360 L / 12.71 cu.ft.
<b>Electrical</b>	110V / 60Hz / 1
<b>Lamp Power</b>	2.8 W x 2 (LED)
<b>Temperature Range</b>	2 - 10°C / 35.6 - 50°F
<b>Max Ambient Temperature / RH</b>	<27°C (80.6°F) / 70%
<b>Refrigerant &amp; Injection</b>	R404a, 660g
<b>Type of Climate</b>	6
<b>Rated Current</b>	11.6 A
<b>Foaming Agent</b>	XPS
<b>Weight</b>	277 lbs. / 126 kgs.
<b>Packaging Weight</b>	321 lbs. / 146 kgs.
<b>Dimensions</b>	34.5" x 37" x 65" / 876 x 945 x 1656mm
<b>Packaging Dimensions</b>	37.4" x 40.2" x 62.6" / 950 x 1020 x 1590mm
<b>Item Number</b>	41465

## BEFORE USE

- Plug refrigerator into the 110V exclusive socket.
- After the refrigerator is running, confirm that air suction/filtration is in working order and that it is sufficiently cold. After checking to make sure the refrigerator is working properly, it may be used.

## DIGITAL TEMPERATURE CONTROLLER

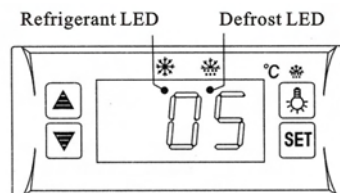

## FEATURES OF FUNCTION

- Small, integrated digital controller, which is applicable to the compressor of 1 Hp. Located behind the front grill.
- Main functions are: Temperature Display/Temperature Control/Manual-Automatic /Light Control/Value Storing/Self-Testing/Parameter Locking.

## FRONT PANEL OPERATION

1. Set temperature: Press **SET** button; set temperature will be displayed. Press **▲** or **▼** button to modify and store the displayed value. Press **SET** button to exit the adjustment and display the cold-room temperature.
2. If no button is pressed within 10 seconds, the cold-room temperature will be displayed.
3. Lighting: Press **☹** button to activate light in refrigerator; press again to turn off. Manual start/stop defrost: Press **☹** button and hold for 6 seconds to either defrost or to stop defrost.
4. Refrigeration LED: During refrigeration, the LED is on. When the cold room temperature is constant, the LED is off. During delay start, the LED flashes.
5. Defrost LED: During defrosting, the LED is on. When it stops defrosting, the LED is off. During the delay of defrost, the LED flashed.

# Maintenance

## CABINET CLEANING

The product should be cleaned once a week with the power supply disconnected. When cleaning please use a mild cleansing agent. Only use a damp cloth.

# Maintenance

---

## CLEANING THE FILTER

When message “EE4” appears on the display, please clean the filter immediately. If the error message still appears after cleaning the filter, please contact Omcan.

### INSTRUCTIONS FOR CLEANING THE FILTER

1. Remove the four screws from the top of the front grill.
2. Pull out the front grill.
3. Take out the filter.

### CHECK FOR LEAKS

Observe all connectors and welding joints for oil stains. This indicates that there is a leak, please call Omcan if you notice any oil stains.

**ALWAYS OBSERVE THE OPERATION OF THE UNIT, IN THE EVENT OF ANY ABNORMAL SOUNDS OR SMELLS, OR IF THE UNIT BEGINS TO SMOKE, DISCONNECT THE UNIT FROM THE POWER SUPPLY AND CALL OMCAN.**

# Troubleshooting

---

Trouble	Causes	Solutions
Strange noise under the bottom shelf.	Fan blade broken.	Power off and fix the blade.
Non-refrigerating in spite of normal operation.	Unit off.	Power on.
	Melting process.	Stop melting.
	Refrigerant leaking.	Patch the leak and refill refrigerant.
	Unit failure.	Call Omcan.
Weak air from air curtain, and higher cabinet temperature.	Evaporator blocked by frost.	Increase melting frequency.
	Inside fan damaged.	Replace the fan.
	Too low point of temperature controller.	Adjust the set point.
	Vent blocked by storage.	Remove the storage.
Normal air curtain, but higher cabinet temperature.	Insufficient refrigerant.	Refill the refrigerant.
	Too high set point of temperature controllers.	Adjust the set point for the temperature controller.
	The wind curtain disturbed by strong air flow.	Removing the disturbing factors.
	Ambient temperature or humidity beyond standards.	Improve the conditions.

# Troubleshooting

Melting water overflows.	Heating pipe for melting water damaged.	Replace the heating pipe.
	Water level controller failure.	Replace the water level controller.
	Ambient temperature or humidity beyond standards.	Improve the conditions.
Normal air curtain, but periodical fluctuation of cabinet temperature.	Condenser contaminated.	Clean the condenser.
	Poor venting of the unit.	Improve the venting conditions.
	Heat protection of compressor failure.	Replace the heat protection.
	Capillary is blocked by ice.	Replace the drying filter.
	Temperature controller failure.	Replace the temperature controller.

## NOTE

### Following occurrences are not problems:

- The murmur of water is heard when the refrigerator is working. It is a normal occurrence as the coolant is circulating in the system.
- When the weather is damp, condensation might be found on the outside of the refrigerator. It is caused by high humidity. Simply use cloth to wipe it off.

## REFERENCE

Item Number	Model Number	Description	Manufacturer Model Number
41465	RS-CN-0360	Refrigerated Showcase 360 L / 12.71 cu. ft. 110V/60/1 cETLus	RTS-360L

# Parts Breakdown

Model RS-CN-0360 41465

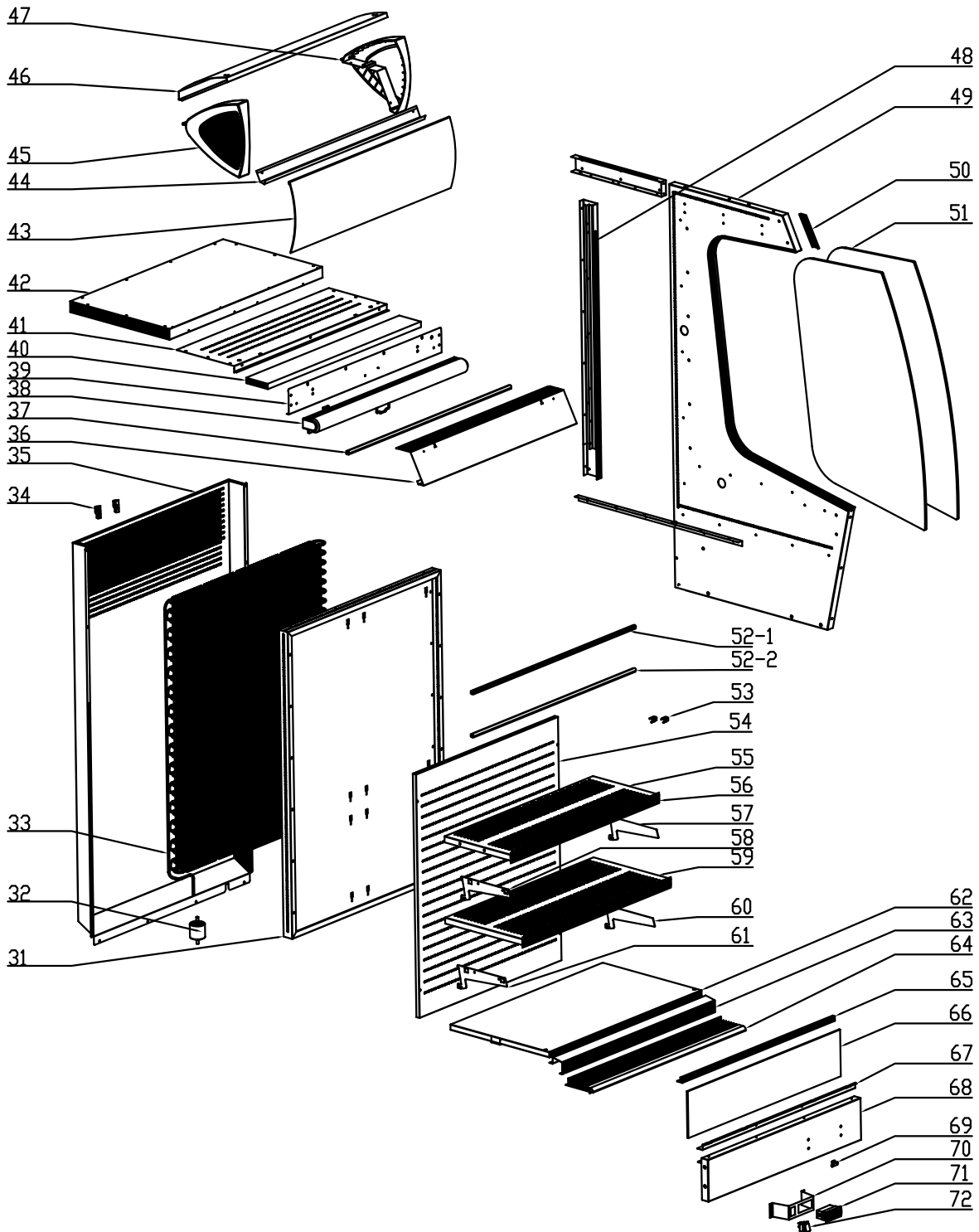

# Parts Breakdown

Model RS-CN-0360 41465

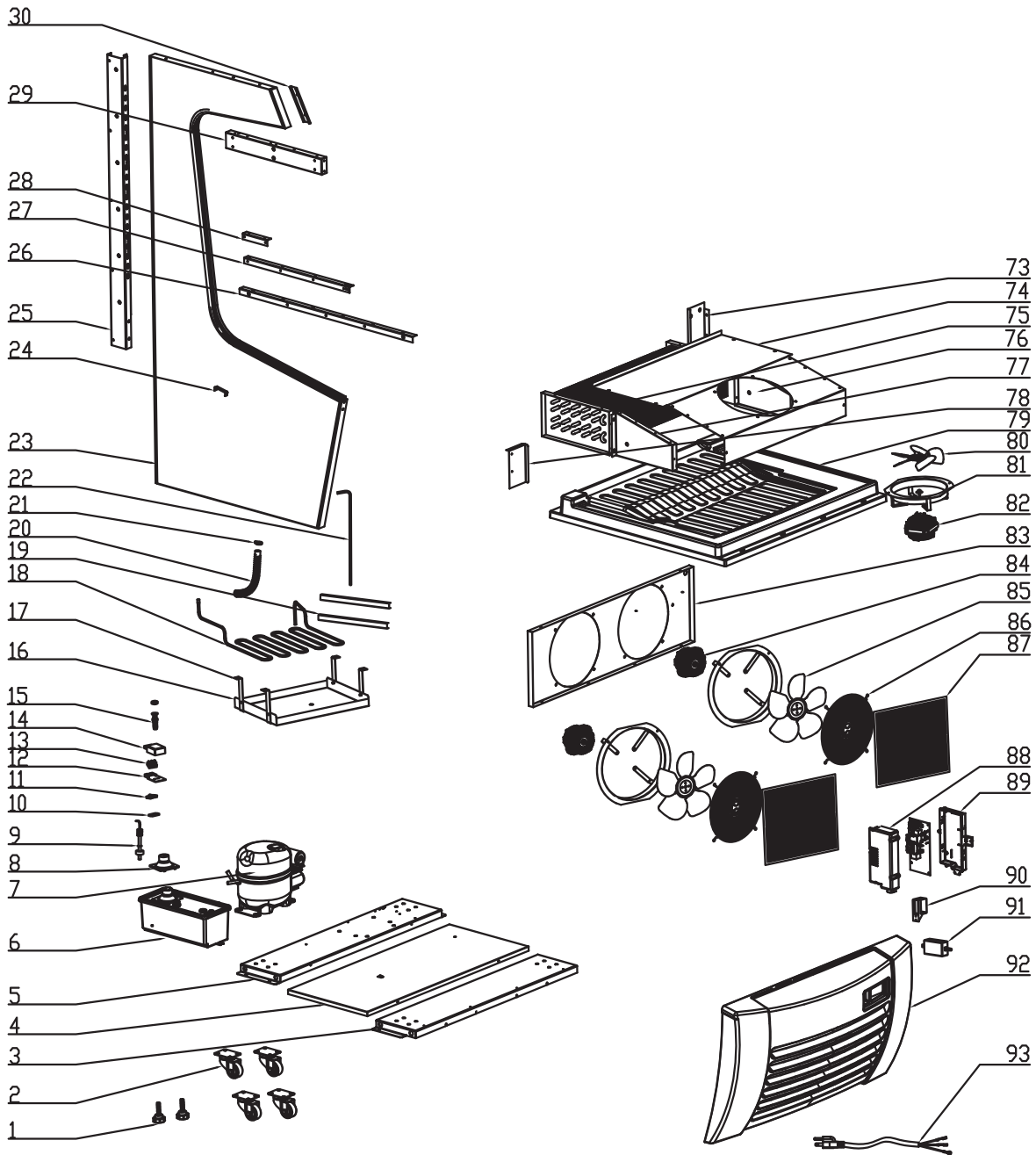

# Parts Breakdown

## Model RS-CN-0360 41465

Item No.	Description	Position	Item No.	Description	Position	Item No.	Description	Position
60672	Feet for RTS-360L	1	61224	Dry Filter for RTS-360L	32	61193	Cover Support - Plastic Coated for RTS-360L	63
60561	Castor for RTS-360L	2	66310	Condenser for RTS-360L	33	61192	Air Inlet Cover for RTS-360L	64
61253	Front Board of Base for RTS-360L	3	61222	Stands for Condenser for RTS-360L	34	61191	Wind Screen Strip for RTS-360L	65
61252	Middle Board of Base for RTS-360L	4	61221	Condenser Cover for RTS-360L	35	66341	Glass Deflector for RTS-360L	66
61251	Fixed Plate for RTS-360L	5	66312	Top Front Panel for RTS-360L	36	61189	Retaining Plate for Front Base Panel for RTS-360L	67
79303	Water Receiver for RTS-360L	6	66313	Top LED Light for RTS-360L	37	61188	Front Board for Evaporator for RTS-360L	68
61249	Compressor for RTS-360L	7	61218	Night Curtain for RTS-360L	38	60651	Curtain Hook for RTS-360L	69
79304	Pipe for Evaporated Water for RTS-360L	8	61217	Board Ahead Curtain for RTS-360L	39	61186	Holder for Digital Display for RTS-360L	70
79305	Water Level Detector for RTS-360L	9	61216	Honeycomb Panel for RTS-360L	40	30885	Digital Controller for RTS-360L	71
61246	Wire Clip Holder for RTS-360L	10	61215	Ceiling Board of Cabinet for RTS-360L	41	71514	Switch for RTS-360L	72
61245	Wire Clip Cover for RTS-360L	11	61214	Foam of Top Cover for RTS-360L	42	61183	Right Wind Screen of Evaporator for RTS-360L	73
61244	Junction Box for RTS-360L	12	61213	Transparent Plate for RTS-360L	43	61182	Evaporator Cover for RTS-360L	74
79292	Terminal for RTS-360L	13	61212	Bottom Frame of Light Box for RTS-360L	44	61181	Evaporator for RTS-360L	75
79359	Cover of Junction Box for RTS-360L	14	61211	Left Panel of Light Box for RTS-360L	45	61180	Right Board of Evaporator Cover for RTS-360L	76
61241	Water Nozzle for RTS-360L	15	61210	Top Frame of Light Box - Plastic Coated for RTS-360L	46	71521	Left Board of Evaporator Cover for RTS-360L	77
61240	Tray of Heater for RTS-360L	16	61209	Right Panel of Light Box for RTS-360L	47	61178	Left Wind Screen of Evaporator for RTS-360L	78
66297	Bracket of Water Receiver for RTS-360L	17	61208	Right Support Pillar of Shelf for RTS-360L	48	61177	Base Foam of Evaporator for RTS-360L	79
61238	Heater for RTS-360L	18	61207	Foam of Right Board for RTS-360L	49	66351	Fan Blade for RTS-360L	80
61237	Platen of Heater for RTS-360L	19	61206	Right Fixed Board of Top Front Panel for RTS-360L	50	60932	Flange for RTS-360L	81
63459	Hose Fitting for RTS-360L	20	66327	Side Glass for RTS-360L	51	60931	Evaporator Fan Motor for RTS-360L	82, 84
71517	Pipe Clip for RTS-360L	21	66328	LED Strip for RTS-360L	52	61173	Holder for Condenser Motor for RTS-360L	83
79317	Connection Pipe for RTS-360L	22	60637	Jump Ring of LED for RTS-360L	53	60933	Fan Blade for RTS-360L	85
61233	Foam of Left Side Board for RTS-360L	23	61202	Ventilated Board for RTS-360L	54	61170	Flat Net Cover for RTS-360L	86
61232	Side Glass Bar for RTS-360L	24	61201	Upper Shelf for RTS-360L	55	61169	Air Filter for RTS-360L	87
61231	Left Support for Shelf for RTS-360L	25	61200	Price Tag Holder for RTS-360L	56	61168	Cover of Circuit Board Box for RTS-360L	88
61230	Connector of Evaporator Base Panel for RTS-360L	26	61199	Right Support Pillar of Shelf for RTS-360L	57	61167	Circuit Board Box for RTS-360L	89
61229	Support for Upper Cover of Base for RTS-360L	27	61198	Left Support Pillar of Shelf for RTS-360L	58	79356	LED Transformer Holder for RTS-360L	90
61228	Air Inlet Stand for RTS-360L	28	61197	Bottom Shelf for RTS-360L	59	60552	Power Actuator for RTS-360L	91
61227	Support for Ceiling for RTS-360L	29	61196	Right Support Pillar of Shelf for RTS-360L	60	61164	Front Base Panel for RTS-360L	92
61226	Left Fixed Board of Top Front Panel for RTS-360L	30	61195	Left Support Pillar of Shelf for RTS-360L	61	79290	Power Cord for RTS-360L	93
61225	Foam of Back Cover for RTS-360L	31	61194	Bottom Board of Cabinet for RTS-360L	62			

# Electrical Schematics

Model RS-CN-0360 41465

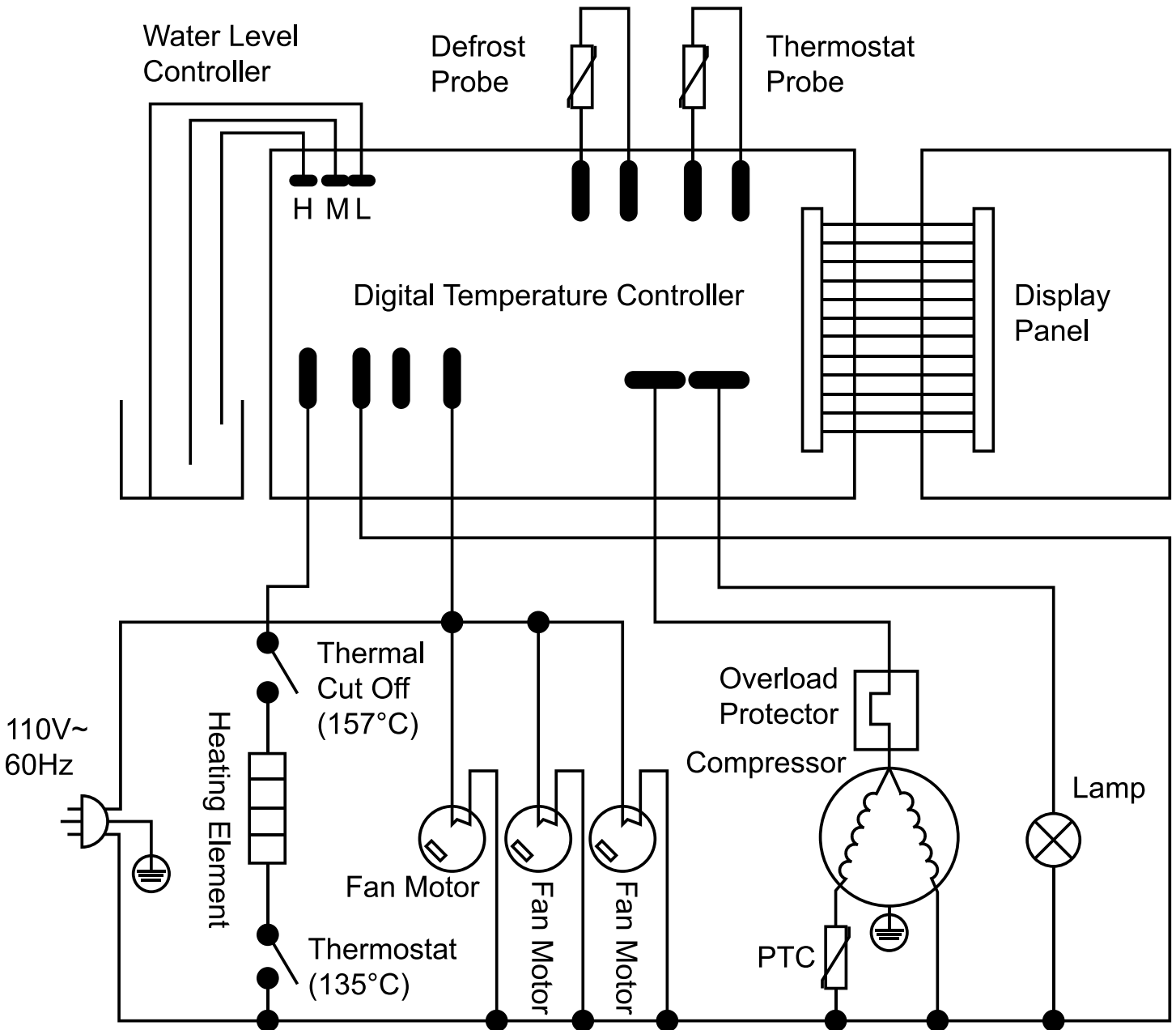





# Warranty Registration

Thank you for purchasing an Omcan product. To register your warranty for this product, complete the information below, tear off the card at the perforation and then send to the address specified below. You can also register online by visiting:

Merci d'avoir acheté un produit Omcan. Pour enregistrer votre garantie pour ce produit, complétez les informations ci-dessous, détachez la carte au niveau de la perforation, puis l'envoyer à l'adresse spécifiée ci-dessous. Vous pouvez également vous inscrire en ligne en visitant:

Gracias por comprar un producto Omcan usted. Para registrar su garantía para este producto, complete la información a continuación, cortar la tarjeta en la perforación y luego enviarlo a la dirección indicada a continuación. También puede registrarse en línea en:

<https://omcan.com/warranty-registration/>

For mailing in Canada

Pour postale au Canada

Por correo en Canadá

**OMCAN**

PRODUCT WARRANTY REGISTRATION

3115 Pepper Mill Court,

Mississauga, Ontario

Canada, L5L 4X5

For mailing in the US

Pour diffusion aux États-Unis

Por correo en los EE.UU.

**OMCAN**

PRODUCT WARRANTY REGISTRATION

4450 Witmer Industrial Estates, Unit 4,

Niagara Falls, New York

USA, 14305

*or email to: [service@omcan.com](mailto:service@omcan.com)*



Purchaser's Information

Name: \_\_\_\_\_

Address: \_\_\_\_\_

City: \_\_\_\_\_ Province or State: \_\_\_\_\_ Postal or Zip: \_\_\_\_\_

Country: \_\_\_\_\_

Dealer from which Purchased: \_\_\_\_\_

Dealer City: \_\_\_\_\_ Dealer Province or State: \_\_\_\_\_

Invoice: \_\_\_\_\_

Model Name: \_\_\_\_\_ Model Number: \_\_\_\_\_

Machine Description: \_\_\_\_\_

Date of Purchase (MM/DD/YYYY): \_\_\_\_\_

Would you like to extend the warranty?  Yes  No

Company Name: \_\_\_\_\_

Telephone: \_\_\_\_\_

Email Address: \_\_\_\_\_

Type of Company:

Restaurant  Bakery  Deli

Butcher  Supermarket  Caterer

Institution (*specify*): \_\_\_\_\_

Other (*specify*): \_\_\_\_\_

Serial Number: \_\_\_\_\_

Date of Installation (MM/DD/YYYY): \_\_\_\_\_

**Thank you for choosing Omcan | Merci d'avoir choisi Omcan | Gracias por elegir Omcan**



Since 1951 Omcan has grown to become a leading distributor of equipment and supplies to the North American food service industry. Our success over these many years can be attributed to our commitment to strengthen and develop new and existing relationships with our valued customers and manufacturers. Today with partners in North America, Europe, Asia and South America, we continually work to improve and grow the company. We strive to offer customers exceptional value through our qualified local sales and service representatives who provide convenient access to over 5,000 globally sourced products.

---

Depuis 1951 Omcan a grandi pour devenir un des “leaders” de la distribution des équipements et matériel pour l’industrie des services alimentaires en Amérique du Nord. Notre succès au cours de ces nombreuses années peut être attribué à notre engagement à renforcer et à développer de nouvelles et existantes relations avec nos clients et les fabricants de valeur. Aujourd’hui avec des partenaires en Amérique du Nord, Europe, Asie et Amérique du Sud, nous travaillons continuellement à améliorer et développer l’entreprise. Nous nous efforçons d’offrir à nos clients une valeur exceptionnelle grâce à nos ventes locales qualifiées et des représentants de service qui offrent un accès facile à plus de 5000 produits provenant du monde entier.

---

Desde 1951 Omcan ha crecido hasta convertirse en un líder en la distribución de equipos y suministros de alimentos en América del Norte industria de servicios. Nuestro éxito en estos años se puede atribuir a nuestro compromiso de fortalecer y desarrollar nuevas relaciones existentes con nuestros valiosos clientes y fabricantes. Hoy con socios de América del Norte, Europa, Asia y América del Sur, que trabajan continuamente para mejorar y crecer la empresa. Nos esforzamos por ofrecer a nuestros clientes valor excepcional a través de nuestro local de ventas y representantes de los servicios que proporcionan un fácil acceso a más de 5,000 productos con origen a nivel mundial.

