



14" Impulse Sealers
Models SE-CN-0358, 0361
Items 14432, 14433
Instruction Manual



Revised - 09/18/2019



Toll Free: 1-800-465-0234
Fax: 905-607-0234
Email: service@omcan.com
www.omcan.com

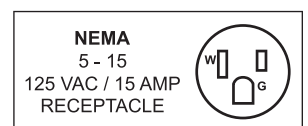

Table of Contents

Model SE-CN-0358 / Model SE-CN-0361

Section	Page
General Information -----	3 - 4
Safety and Warranty -----	4 - 5
Technical Specifications -----	5
Operation -----	6
Maintenance -----	6 - 7
Troubleshooting -----	7 - 8
Parts Breakdown -----	9 - 10
Electrical Schematics -----	11
Notes -----	12 - 14
Warranty Registration -----	15



General Information

Omcan Manufacturing and Distributing Company Inc., Food Machinery of America, Inc. dba Omcan and Omcan Inc. are not responsible for any harm or injury caused due to any person's improper or negligent use of this equipment. The product shall only be operated by someone over the age of 18, of sound mind, and not under the influence of any drugs or alcohol, who has been trained in the correct operation of this machine, and is wearing authorized, proper safety clothing. Any modification to the machine voids any warranty, and may cause harm to individuals using the machine or in the vicinity of the machine while in operation.

CHECK PACKAGE UPON ARRIVAL

Upon receipt of an Omcan shipment please inspect for external damage. If no damage is evident on the external packaging, open carton to ensure all ordered items are within the box, and there is no concealed damage to the machine. If the package has suffered rough handling, bumps or damage (visible or concealed), please note it on the bill of lading before accepting the delivery and contact Omcan within 24 hours, so we may initiate a claim with the carrier. A detailed report on the extent of the damage caused to the machine must be filled out within three days, from the delivery date shown in the shipping documents. Omcan has no recourse for damaged products that were shipped collect or third party.

Before operating any equipment, always read and familiarize yourself with all operation and safety instructions.

Omcan would like to thank you for purchasing this machine. It's of the utmost importance to save these instructions for future reference. Also save the original box and packaging for shipping the equipment if servicing or returning of the machine is required.

Omcan Fabrication et distribution Compañie Limité et Food Machinery d'Amérique, dba Omcan et Omcan Inc. ne sont pas responsables de tout dommage ou blessure causé du fait que toute personne ait utilisé cet équipement de façon irrégulière. Le produit ne doit être exploité que par quelqu'un de plus de 18 ans, saine d'esprit, et pas sous l'influence d'une drogue ou d'alcool, qui a été formé pour utiliser cette machine correctement, et est vêtu de vêtements de sécurité approprié. Toute modification de la machine annule toute garantie, et peut causer un préjudice à des personnes utilisant la machine ou des personnes à proximité de la machine pendant son fonctionnement.

VÉRIFIEZ LE COLIS DÈS RÉCEPTION

Dès réception d'une expédition d'Omcan veuillez inspecter pour dommages externes. Si aucun dommage n'est visible sur l'emballage externe, ouvrez le carton afin de s'assurer que tous les éléments commandés sont dans la boîte, et il n'y a aucun dommage dissimulé à la machine. Si le colis n'a subi aucune mauvaises manipulations, de bosses ou de dommages (visible ou cachée), notez-le sur le bond de livraison avant d'accepter la livraison et contactez Omcan dans les 24 heures qui suivent, pour que nous puissions engager une réclamation auprès du transporteur. Un rapport détaillé sur l'étendue des dommages causés à la machine doit être rempli dans un délai de trois jours, à compter de la date de livraison indiquée dans les documents d'expédition. Omcan n'a aucun droit de recours pour les produits endommagés qui ont été expédiés ou cueilli par un tiers transporteur.

General Information

Avant d'utiliser n'importe quel équipement, toujours lire et vous familiariser avec toutes les opérations et les consignes de sécurité.

Omcan voudrais vous remercier d'avoir choisi cette machine. Il est primordial de conserver ces instructions pour une référence ultérieure. Également conservez la boîte originale et l'emballage pour l'expédition de l'équipement si l'entretien ou le retour de la machine est nécessaire.

Omcan Empresa De Fabricacion Y Distribucion Inc. Y Maquinaria De Alimentos De America, Inc. dba Omcan y Omcan Inc. no son responsables de ningun daño o perjuicio causado por cualquier persona inadecuada o el uso descuidado de este equipo. El producto solo podra ser operado por una persona mayor de 18 años, en su sano juicio y no bajo alguna influencia de droga o alcohol, y que este ha sido entrenado en el correcto funcionamiento de esta máquina, y ésta usando ropa apropiada y autorizada. Cualquier modificación a la máquina anula la garantía y puede causar daños a las personas usando la máquina mientras esta en el funcionamiento.

REVISE EL PAQUETE A SU LLEGADA

Tras la recepcion de un envio Omcan favor inspeccionar daños externos. Si no hay daños evidentes en el empaque exterior, Habra el carton para asegurarse que todos los articulos solicitados estén dentro de la caja y no encuentre daños ocultos en la máquina. Si el paquete ha sufrido un manejo de poco cuidado, golpes o daños (visible o oculto) por favor anote en la factura antes de aceptar la entrega y contacte Omcan dentro de las 24 horas, de modo que podamos iniciar una reclamación con la compañía. Un informe detallado sobre los daños causados a la máquina debe ser llenado en el plazo de tres días, desde la fecha de entrega que se muestra en los documentos de envío. Omcan no tiene ningun recurso por productos dañados que se enviaron a recoger por terceros.

Antes de utilizar cualquier equipo, siempre leer y familiarizarse con todas las instrucciones de operación y seguridad.

Omcan quisiera darles las gracias por la compra de esta máquina. Es de la máxima importancia para guardar estas instrucciones para referencias en el futuro. También guarde la caja original y el embalaje para envío del equipo si el mantenimiento o la devolución de la máquina es necesaria.

Safety and Warranty

- This machine should only be installed and operated by trained personnel. Do not change the electrical wiring of the machine.
- Read all instructions carefully and do not operate the machine until the operator has fully read this manual.
- Do not use the machine without the personal safety equipment.
- Keep hands, long hair, foreign objects, clothes and jewelry away from any moving parts.
- Do not leave the machine unattended while the unit is on or in operation.
- Always turn off and unplug the unit before performing any maintenance.



Safety and Warranty

1 YEAR PARTS AND LABOR WARRANTY

Within the warranty period, contact Omcan Inc. at 1-800-465-0234 to schedule an Omcan authorized service technician to repair the equipment locally.

Unauthorized maintenance will void the warranty. Warranty covers electrical and part failures, not improper use.

Please see <https://omcan.com/disclaimer> for complete info.

WARNING:

The packaging components (cardboard, polyethylene, and others) are classified as normal solid urban waste and can therefore be disposed of without difficulty.

In any case, for suitable recycling, we suggest disposing of the products separately (differentiated waste) according to the current norms.

DO NOT DISCARD ANY PACKAGING MATERIALS IN THE ENVIRONMENT!

Technical Specifications

Model	SE-CN-0358	SE-CN-0361
Description	14" seal bar - 2mm seal width	14" seal bar - 5mm seal width
Electrical	110V / 60Hz / 1Ph	
Weight	42 lbs. / 19 kgs.	
Packaging Weight	45 lbs. / 20.4 kgs.	
Dimensions	20.75" x 16.5" x 33.5" / 527 x 419 x 851mm	
Packaging Dimensions	21.5" x 31" x 10" / 546 x 787 x 254mm	
Item Number	14432	14433

Operation



Fig. 1 - Diagram of the control panel for the impulse sealer

ADJUSTMENT AND USAGE OF IMPULSE SEALER

Connect to 110V power source according to the indication label on the machine. Switch on the power, the red light will turn on. Adjust the sealing time according to the materials and the thickness of the bags to be sealed. The sealing time should be adjusted to around grade 1 before sealing. Put the opening of the bag between the heat sealers, step down on the pedal and the yellow lamp lights. Take out the sealed bag after the yellow lamp is off. If the seal is not tight enough, lengthen the sealing time. Try sealing the bag several times until it is sealed well with clearness and no wrinkles. Seal the bag at this measured time and temperature. The cooling time should not be too short, otherwise wrinkles will be the result. The longer the sealing time, the longer the cooling time.

Maintenance

Never try to seal without bags. Don't set the sealing time to the high grade without trial of the sealing bag. Otherwise, the polymer cloth will be burned. If some plastics adheres to the polymer cloth, never try to scrape it off. Slightly reduce the sealing time and seal the bag again. Release the pedal after the yellow lamp is off. It is very important to remove the bag from one side to the other. The remains of the plastics will be cleared from the polymer cloth with the bag.

REPLACEMENT OF THE HEATER

Turn off sealer and unplug from the wall. Loosen the screws of the plate pressing the polymer cloth, roll back the cloth to expose the heater. Loosen the Bakelite boxes at both sides of the heater and take out the screws on the copper block. The heater can now be removed. Replace it with a new one. The heater should always be in tension with the function of the spring. The copper block should be replaced if it is oxidized, to ensure it has a good connection with the heater. Pay close attention when fixing the heater so that the polymer cloth below is flat (no wrinkles are allowed). The heater must have a excellent isolation. Otherwise the heater will be

Maintenance

damaged because of the short-circuiting.

REPLACEMENT OF THE POLYMER CLOTH

Turn off sealer and unplug from the wall. Remove the screws and the plates above the polymer cloth, loosen the shaft of the polymer cloth roll, pull out the cloth and cut out the burned part. Reassemble the plates and screws, tighten the roll shaft. No wrinkles are allowed in the polymer cloth, otherwise the seal quality will be affected.

REPLACEMENT OF THE MICRO-SWITCH

Turn off sealer and unplug from the wall. There is one micro-switch at the side of the machine head. It must be replaced when it is damaged. The adjustment of the pressing pole for micro-switch are as follows:

- Put 1mm thick carton between the upper and lower and lower pressing arms, check if the micro-switch is pressed and if there is a “click” from the switch.
- If it is not pressed, adjust down the pressing pole or tighten the nut until the switch is pressed 1-2mm down when it works.
- Always keep the sealing surface clean. Otherwise, the remains in the sealing surface will shorten the life of the heater and the life of the polymer cloth.
- When working, never try to clean the sealing surface with wet cloth.
- After long time usage, the rubber in the upper pressing arm must be checked if it is still flat and straight. Otherwise, the seal quality will be affected.
- Often add lubricating oil into the moving parts.
- All parts in the machine should not be disassembled regularly.

Troubleshooting

Problem	Causes and Solution
The seal is not good.	Lengthen the sealing time if it is not tight enough. Shorten the sealing time if the seal is melted or if the melted seal is creased by not being pressed tightly.
The seal is wrinkled.	<ol style="list-style-type: none"> 1. The problem may be overheating. In this case, shorten the sealing time. 2. The problem may be insufficient time for cooling. In this case, lengthen the cooling time.
The temperature rises when working for some time.	It is normal that the temperature of the machine rises because the unit absorbs heat during operation. Shorten the sealing time slightly to balance the heat.
The power lamp does not light and the sealer does not work.	Check if the power switch is on and if the fuse is damaged.

Troubleshooting

The power lamp lights but the sealing lamp is off and the sealer does not work.	Step down on the pedal to check if the micro-switch works. Adjust if necessary (see "REPLACEMENT OF MICRO-SWITCH).
The sealer is always electrified when the power is switched on.	Switch the power off at once. Check the status of the micro-switch. Adjust if necessary (see "REPLACEMENT OF MICRO-SWITCH).

REFERENCE

Item Number	Model Number	Description	Manufacturer Model Number
14432	SE-CN-0358	Sealer Impulse Foot Operated 14" / 356mm Seal Bar 2mm Seal Width 110V/60/1 cQPSus	F3502
14433	SE-CN-0361	Sealer Impulse Foot Operated 14" / 356mm Seal Bar 5mm Seal Width 110V/60/1 cQPSus	F3505

Parts Breakdown

Model SE-CN-0358 14432

Model SE-CN-0361 14433

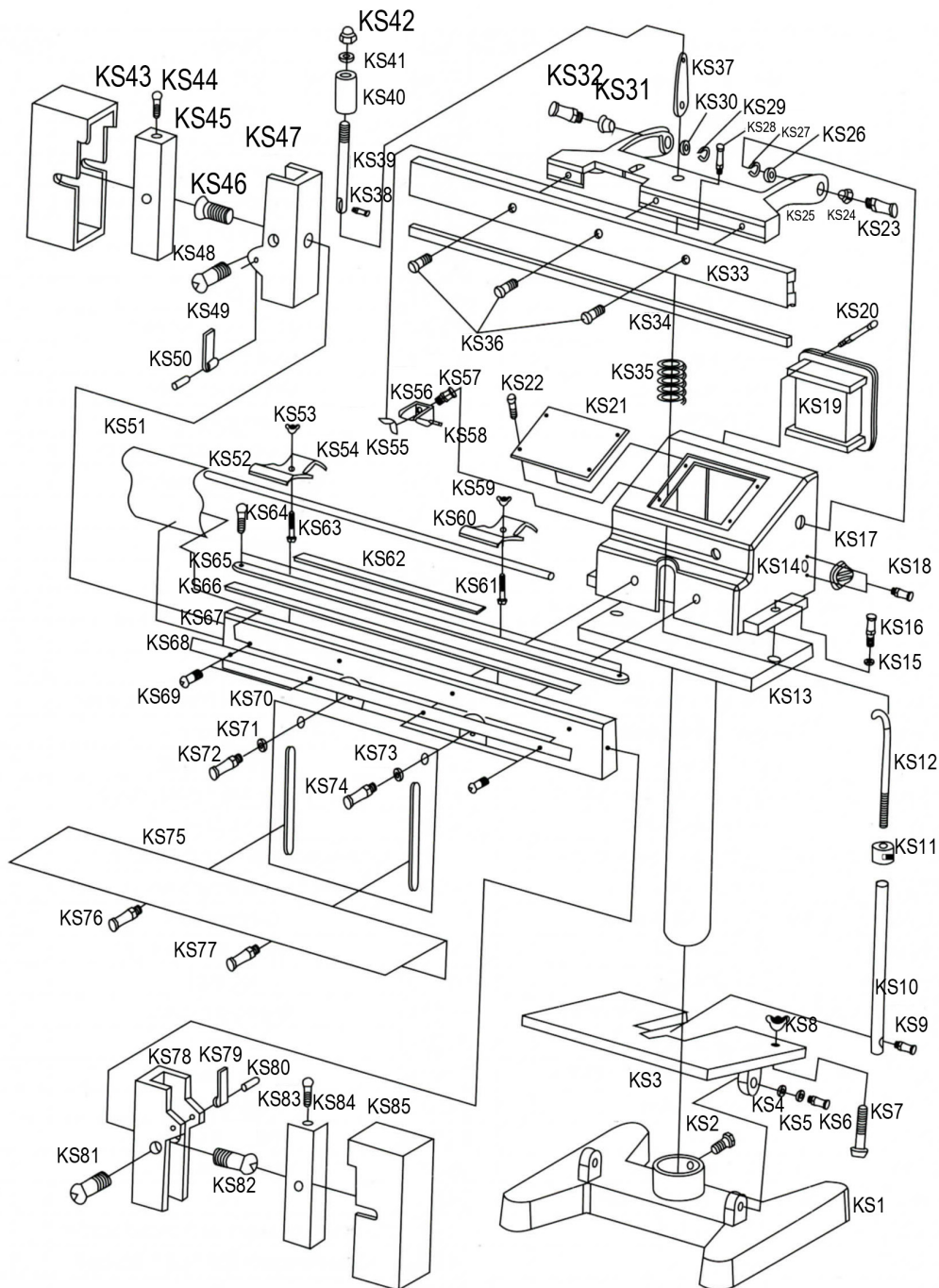

Parts Breakdown

Model SE-CN-0358 14432

Model SE-CN-0361 14433

Item No.	Description	Position	Item No.	Description	Position	Item No.	Description	Position
75287	Machine Base for F3502 & F3505	KS1	75311	Upper Sealing Shelf for F3502 & F3505	KS25	75341	Touching Board for F3502 & F3505	KS55-56
75288	Bolt for F3502 & F3505	KS2	75312	Tetrafluorohydrazine Convention for F3502 & F3505	KS26	75342	Switch Shelf for F3502 & F3505	KS57-58
75289	Pedal Board for F3502 & F3505	KS3	75313	Flexible Mat for F3502 & F3505	KS27	75345	Butterfly Nuts for F3502 & F3505	KS59
75290	Flat Washer for F3502 & F3505	KS4	75314	Inner Hex Screw and Nut for F3502 & F3505	KS28	75346	Pressor for F3502 & F3505	KS60
75291	Nut for F3502 & F3505	KS5	75315	Flexible Mat for F3502 & F3505	KS29	75347	Bolt for F3502 & F3505	KS61
75292	Bolt for F3502 & F3505	KS6	75316	Flat Washer for F3502 & F3505	KS30	75348	Insulated Pad for F3502 & F3505	KS62
75293	Adjusting Bolt for F3502 & F3505	KS7	75317	Tetrafluorohydrazine Convention for F3502 & F3505	KS31	75349	Bolt for F3502 & F3505	KS63
75294	Butterfly Nut for F3502 & F3505	KS8	75318	Bolt Groups for F3502 & F3505	KS32	75350	Countersink Flat Head Screws for F3502 & F3505	KS64
75295	Bolt Groups for F3502 & F3505	KS9	75319	Upper Sealing Silicon Fasten Block for F3502 & F3505	KS33	75351	Heater for F3502 & F3505	KS65
75296	Pedal Board Tie for F3502 & F3505	KS10	17737	Silicon Rubbers for F3502 & F3505	KS34	75352	Insulated Pad for F3502 & F3505	KS66
75297	Connecting Nut for F3502 & F3505	KS11	75321	Spring for F3502 & F3505	KS35	75353	Lower Sealing Fasten Base for F3502 & F3505	KS67
75298	Coupler Tie for F3502 & F3505	KS12	75322	Inner Hex Screw and Nut for F3502 & F3505	KS36	75354	Polymer Pressor for F3502 & F3505	KS68
75299	Upright Column Base for F3502 & F3505	KS13	75323	Small Connecting Board for F3502 & F3505	KS37	75355	Cross Recessed Pan Head Screw for F3502 & F3505	KS69
75300	Machine Cover for F3502 & F3505	KS14	75324	Flexible Pin for F3502 & F3505	KS38	75356	Fasten Board of Working Table for F3502 & F3505	KS70
75301	Nut for F3502 & F3505	KS15	75325	Tie for F3502 & F3505	KS39	75357	Flat Cushion for F3502 & F3505	KS71
75302	Screw and Flat Gasket for F3502 & F3505	KS16	75326	Rubber Cushion for F3502 & F3505	KS40	75358	Bolts Groups for F3502 & F3505	KS72
75303	Wire Guider for F3502 & F3505	KS17	75327	Washer for F3502 & F3505	KS41	75359	Flat Mat for F3502 & F3505	KS73
75304	Cross Recessed Pan Head Screw for F3502 & F3505	KS18	75328	Cap Nuts for F3502 & F3505	KS42	75360	Bolts Groups for F3502 & F3505	KS74
75305	Transformers and Back Cover for F3502 & F3505	KS19	75329	Plastic Cover for F3502 & F3505	KS43	75361	Flat Mat for F3502 & F3505	KS75
75306	Bolt for F3502 & F3505	KS20	75364	Ceramic Base for F3502 & F3505	KS44-50	75358	Bolt Groups for F3502 & F3505	KS76
75307	Operation Panel for F3502 & F3505	KS21	75337	Polymer for F3502 & F3505	KS51	75360	Bolt Groups for F3502 & F3505	KS77
75308	Countersink Screw for F3502 & F3505	KS22	75338	Axles for Polymer for F3502 & F3505	KS52	75364	Ceramic Base for F3502 & F3505	KS78-84
75309	Bolt Groups for F3502 & F3505	KS23	75339	Butterfly Nut for F3502 & F3505	KS53	75329	Plastic Cover for F3502 & F3505	KS85
75310	Tetrafluorohydrazine Convention for F3502 & F3505	KS24	75340	Hold-Down Plate for F3502 & F3505	KS54			



Warranty Registration

Thank you for purchasing an Omcan product. To register your warranty for this product, complete the information below, tear off the card at the perforation and then send to the address specified below. You can also register online by visiting:

Merci d'avoir acheté un produit Omcan. Pour enregistrer votre garantie pour ce produit, complétez les informations ci-dessous, détachez la carte au niveau de la perforation, puis l'envoyer à l'adresse spécifiée ci-dessous. Vous pouvez également vous inscrire en ligne en visitant:

Gracias por comprar un producto Omcan usted. Para registrar su garantía para este producto, complete la información a continuación, cortar la tarjeta en la perforación y luego enviarlo a la dirección indicada a continuación. También puede registrarse en línea en:

<https://omcan.com/warranty-registration/>

For mailing in Canada

Pour postale au Canada

Por correo en Canadá

For mailing in the US

Pour diffusion aux États-Unis

Por correo en los EE.UU.

OMCAN

PRODUCT WARRANTY REGISTRATION

3115 Pepper Mill Court,

Mississauga, Ontario

Canada, L5L 4X5

OMCAN

PRODUCT WARRANTY REGISTRATION

4450 Witmer Industrial Estates, Unit 4,

Niagara Falls, New York

USA, 14305

or email to: service@omcan.com



Purchaser's Information

Name: _____

Address: _____

City: _____ Province or State: _____ Postal or Zip: _____

Country: _____

Dealer from which Purchased: _____

Dealer City: _____ Dealer Province or State: _____

Invoice: _____

Model Name: _____ Model Number: _____

Machine Description: _____

Date of Purchase (MM/DD/YYYY): _____

Would you like to extend the warranty? Yes No

Company Name: _____

Telephone: _____

Email Address: _____

Type of Company:

Restaurant Bakery Deli

Butcher Supermarket Caterer

Institution (specify): _____

Other (specify): _____

Serial Number: _____

Date of Installation (MM/DD/YYYY): _____

Thank you for choosing Omcan | Merci d'avoir choisi Omcan | Gracias por elegir Omcan



Since 1951 Omcan has grown to become a leading distributor of equipment and supplies to the North American food service industry. Our success over these many years can be attributed to our commitment to strengthen and develop new and existing relationships with our valued customers and manufacturers. Today with partners in North America, Europe, Asia and South America, we continually work to improve and grow the company. We strive to offer customers exceptional value through our qualified local sales and service representatives who provide convenient access to over 5,000 globally sourced products.

Depuis 1951 Omcan a grandi pour devenir un des “leaders” de la distribution des équipements et matériel pour l’industrie des services alimentaires en Amérique du Nord. Notre succès au cours de ces nombreuses années peut être attribué à notre engagement à renforcer et à développer de nouvelles et existantes relations avec nos clients et les fabricants de valeur. Aujourd’hui avec des partenaires en Amérique du Nord, Europe, Asie et Amérique du Sud, nous travaillons continuellement à améliorer et développer l’entreprise. Nous nous efforçons d’offrir à nos clients une valeur exceptionnelle grâce à nos ventes locales qualifiées et des représentants de service qui offrent un accès facile à plus de 5000 produits provenant du monde entier.

Desde 1951 Omcan ha crecido hasta convertirse en un líder en la distribución de equipos y suministros de alimentos en América del Norte industria de servicios. Nuestro éxito en estos años se puede atribuir a nuestro compromiso de fortalecer y desarrollar nuevas relaciones existentes con nuestros valiosos clientes y fabricantes. Hoy con socios de América del Norte, Europa, Asia y América del Sur, que trabajan continuamente para mejorar y crecer la empresa. Nos esforzamos por ofrecer a nuestros clientes valor excepcional a través de nuestro local de ventas y representantes de los servicios que proporcionan un fácil acceso a más de 5,000 productos con origen a nivel mundial.

