

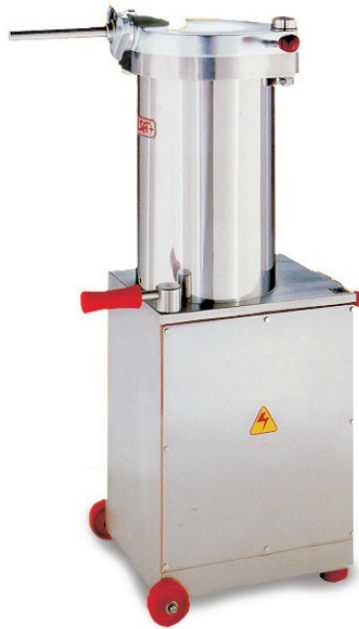

Sausage Stuffers

Models SS-ES-0015, 0020, 0026, 0031, 0042, 0052
Items *13743, *13744, 41708, *13745, 13746, *13750, 13752, *13751,
*13753, *41709, *13755, 13756, 13757, 13758, 13759, 17146

Instruction Manual



Revised - 12/07/2017



Toll Free: 1-800-465-0234
Fax: 905-607-0234
Email: service@omcan.com
www.omcan.com



Table of Contents

Model SS-ES-0015-PA / Model SS-ES-0015-PAM / Model SS-ES-0020-PA
Model SS-ES-0020-PAM / Model SS-ES-0026-PA / Model SS-ES-0026-PAM
Model SS-ES-0026-PAS / Model SS-ES-0026-PASM / Model SS-ES-0031-PAS
Model SS-ES-0031-PASM / Model SS-ES-0042-PAS / Model SS-ES-0042-PASM
Model SS-ES-0052-PAS / Model SS-ES-0052-PASM

Section	Page
General Information -----	3 - 4
Safety and Warranty -----	4 - 6
Technical Specifications -----	7
Installation -----	7 - 9
Operation -----	9 - 10
Maintenance -----	11 - 15
Troubleshooting -----	15 - 16
Parts Breakdown -----	17 - 23
Electrical Schematics -----	24 - 25
Notes -----	26
Warranty Registration -----	27



General Information

Omcan Manufacturing and Distributing Company Inc., Food Machinery of America, Inc. dba Omcan and Omcan Inc. are not responsible for any harm or injury caused due to any person's improper or negligent use of this equipment. The product shall only be operated by someone over the age of 18, of sound mind, and not under the influence of any drugs or alcohol, who has been trained in the correct operation of this machine, and is wearing authorized, proper safety clothing. Any modification to the machine voids any warranty, and may cause harm to individuals using the machine or in the vicinity of the machine while in operation.

CHECK PACKAGE UPON ARRIVAL

Upon receipt of an Omcan shipment please inspect for external damage. If no damage is evident on the external packaging, open carton to ensure all ordered items are within the box, and there is no concealed damage to the machine. If the package has suffered rough handling, bumps or damage (visible or concealed), please note it on the bill of lading before accepting the delivery and contact Omcan within 24 hours, so we may initiate a claim with the carrier. A detailed report on the extent of the damage caused to the machine must be filled out within three days, from the delivery date shown in the shipping documents. Omcan has no recourse for damaged products that were shipped collect or third party.

Before operating any equipment, always read and familiarize yourself with all operation and safety instructions.

Omcan would like to thank you for purchasing this machine. It's of the utmost importance to save these instructions for future reference. Also save the original box and packaging for shipping the equipment if servicing or returning of the machine is required.

Omcan Fabrication et distribution Compagnie Limitée et Food Machinery d'Amérique, dba Omcan et Omcan Inc. ne sont pas responsables de tout dommage ou blessure causé du fait que toute personne ait utilisé cet équipement de façon irrégulière. Le produit ne doit être exploité que par quelqu'un de plus de 18 ans, sain d'esprit, et pas sous l'influence d'une drogue ou d'alcool, qui a été formé pour utiliser cette machine correctement, et est vêtu de vêtements de sécurité appropriés. Toute modification de la machine annule toute garantie, et peut causer un préjudice à des personnes utilisant la machine ou des personnes à proximité de la machine pendant son fonctionnement.

VÉRIFIEZ LE COLIS DÈS RÉCEPTION

Dès réception d'une expédition d'Omcan veuillez inspecter pour dommages externes. Si aucun dommage n'est visible sur l'emballage externe, ouvrez le carton afin de s'assurer que tous les éléments commandés sont dans la boîte, et il n'y a aucun dommage dissimulé à la machine. Si le colis n'a subi aucune mauvaises manipulations, de bosses ou de dommages (visible ou cachée), notez-le sur le bond de livraison avant d'accepter la livraison et contactez Omcan dans les 24 heures qui suivent, pour que nous puissions engager une réclamation auprès du transporteur. Un rapport détaillé sur l'étendue des dommages causés à la machine doit être rempli dans un délai de trois jours, à compter de la date de livraison indiquée dans les documents d'expédition. Omcan n'a aucun droit de recours pour les produits endommagés qui ont été expédiés ou cueilli par un tiers transporteur.

General Information

Avant d'utiliser n'importe quel équipement, toujours lire et vous familiariser avec toutes les opérations et les consignes de sécurité.

Omcan voudrais vous remercier d'avoir choisi cette machine. Il est primordial de conserver ces instructions pour une référence ultérieure. Également conservez la boîte originale et l'emballage pour l'expédition de l'équipement si l'entretien ou le retour de la machine est nécessaire.

Omcan Empresa De Fabricacion Y Distribucion Inc. Y Maquinaria De Alimentos De America, Inc. dba Omcan y Omcan Inc. no son responsables de ningun daño o perjuicio causado por cualquier persona inadecuada o el uso descuidado de este equipo. El producto solo podra ser operado por una persona mayor de 18 años, en su sano juicio y no bajo alguna influencia de droga o alcohol, y que este ha sido entrenado en el correcto funcionamiento de esta máquina, y ésta usando ropa apropiada y autorizada. Cualquier modificación a la máquina anula la garantía y puede causar daños a las personas usando la máquina mientras esta en el funcionamiento.

REVISE EL PAQUETE A SU LLEGADA

Tras la recepcion de un envio Omcan favor inspeccionar daños externos. Si no hay daños evidentes en el empaque exterior, Habra el carton para asegurarse que todos los articulos solicitados estén dentro de la caja y no encuentre daños ocultos en la máquina. Si el paquete ha sufrido un manejo de poco cuidado, golpes o daños (visible o oculto) por favor anote en la factura antes de aceptar la entrega y contacte Omcan dentro de las 24 horas, de modo que podamos iniciar una reclamación con la compañía. Un informe detallado sobre los daños causados a la máquina debe ser llenado en el plazo de tres días, desde la fecha de entrega que se muestra en los documentos de envío. Omcan no tiene ningun recurso por productos dañados que se enviaron a recoger por terceros.

Antes de utilizar cualquier equipo, siempre lea y familiarizarse con todas las instrucciones de funcionamiento y seguridad.

Omcan le gustaría darle las gracias por la compra de esta máquina. Es de la mayor importancia para salvar estas instrucciones para futuras consultas. Además, guarda la caja original y el embalaje para el envío del equipo si servicio técnico o devolución de la máquina que se requiere.

Safety and Warranty

This machine has moving mechanical parts and uses voltages that are potentially hazardous. Severe, even life-threatening, personal injury could result if the instructions contained in this manual are not followed. Before operating the unit, please read this manual thoroughly. This manual should be kept for future reference and given to every user of the machine. The following clauses limit the liability of the manufacturer and its representatives:

- This machine should only be installed by a qualified electrician. Once installed, do not tamper with the

Safety and Warranty

electrical wiring or components of the machine.

- Do not use the machine without having received previous instructions about its use, maintenance and safety devices from an experienced operator.
- Read the instruction manual carefully before using the machine.
- Do not use the machine without the personal safety equipment required by law.
- Do not tamper with the fixed guards, the safety interlock electrical switches or any other safety devices.
- Always keep hands at a safe distance from the moving parts of the machine.
- Do not leave machine unattended while switched on or in operation.
- Always disconnect the power supply before removing shrouds, removable guards, covers, doors, fences, panels, etc. for servicing, cleaning, or repairs.
- Do not open the machine or tamper with its internal parts. There are no internal components that require adjustment or maintenance on the part of the user.
- Should the machine malfunction, turn it off immediately and notify the supervisor.
- Installation must be in accordance with the operating instructions and with local and state hygiene standards and safety codes. Compliance with codes is the responsibility of the Owner and Installer.
- Before operating the machine, make sure that it is properly grounded and/or connected to a circuit leakage breaker and thermal switch. Failure to do so could result in electric shock.
- Make sure the safety signs and stickers are firmly affixed to the machine, that they are legible, and that they have not been blurred or erased after the machine is cleaned. If they become damaged or lost, ask your dealer for new ones and replace them.
- Keep your work area well lit and free of obstacles.
- When operating the machine never wear loose clothing or jewelry that could get caught in the moving parts.
- Disconnect power.
- Keep children and on-lookers at a safe distance.
- Do not pull on the cord to remove the electrical plug from the socket.
- To avoid damaging the electrical cord, keep it out of areas where it can be stepped on.
- Do not alter or modify the machine's original design in any way.
- Should the machine need repairs, consult the official dealer where the machine was purchased.
- Use only genuine TALSA parts and accessories and have them properly installed by a qualified technician.
- This machine has been designed exclusively for meat processing. Any other use of this machine is not in accordance with its intended application. The manufacturer assumes no responsibility for any possible damage or injury resulting from improper use of this machine.

Additional operating instruction manuals are available from your dealer. Your local dealer will be happy to answer any further questions you may have.

LIST OF POSSIBLE OPERATING HAZARDS

Read and review thoroughly the following operating hazards.

MECHANICAL HAZARDS

- Crushing hands, fingers etc. on the barrel when closing the lid.
- Crushing hands, fingers etc. between the lid and the piston while the latter is being raised, especially when the lid is not completely open.

Safety and Warranty

- Crushing hands, fingers etc. between the piston and the upper part of the base during the dismantling of the removable barrel on E models.
- Personal injury should the machine tip over if it is raised too high while being moved (since the fillers are on wheels, this is an important hazard).
- Foot injuries should the piston fall during dismantling or cleaning.

ELECTRICAL HAZARDS

- Electric shock due to direct or indirect contact with electrical current.
- Electric shock due to defective electrical parts.

NOISE HAZARDS

- Hearing damage should any modification of the machine's original design raise noise emission levels above 85 dB(A).

PERSONAL HEALTH HAZARDS

- Changes in the nature of the food mixture if hygiene and cleaning instructions have not been followed.

1 YEAR PARTS AND LABOR WARRANTY

Within the warranty period, contact Omcan Inc. at 1-800-465-0234 to schedule an Omcan authorized service technician to repair the equipment locally.

Unauthorized maintenance will void the warranty. Warranty covers electrical and part failures, not improper use.

Please see www.omcan.com/warranty.html for complete info.

WARNING:

The packaging components are classified as normal solid urban waste and can therefore be disposed of without difficulty.

In any case, for suitable recycling, we suggest disposing of the products separately (differentiated waste) according to the current norms.

DO NOT DISCARD ANY PACKAGING MATERIALS IN THE ENVIRONMENT!



Technical Specifications

Model	HP	Capacity	Electrical	Weight	Item Number
SS-ES-0015-PA	0.75 HP	33 lbs.	208V/60/3	223 lbs.	13743
SS-ES-0015-PAM	1.75 HP	33 lbs.	220V/60/1	223 lbs.	13744
			110V/60/1		41708
SS-ES-0020-PA	0.75 HP	44 lbs.	208V/60/3	231.5 lbs.	13745
SS-ES-0020-PAM	1.75HP	44 lbs.	220V/60/1	231.5 lbs.	13746
SS-ES-0026-PA	1.5 HP	57 lbs.	208V/60/3	289 lbs.	13750
SS-ES-0026-PAS	1.5 HP	57 lbs.	208V/60/3	289 lbs.	13752
SS-ES-0026-PAM	2.25 HP	57 lbs.	220V/60/1	289 lbs.	13751
SS-ES-0026-PASM	2.25 HP	57 lbs.	220V/60/1	289 lbs.	13753
			110V/60/1		41709
SS-ES-0031-PAS	2 HP	68 lbs.	220V/60/3	315.25 lbs.	13755
SS-ES-0031-PASM	2.25 HP	68 lbs.	220V/60/1	315.25 lbs.	13756
SS-ES-0042-PAS	2.5 HP	92 lbs.	220V/60/3	527 lbs.	13757
SS-ES-0042-PASM	2.5 HP	92 lbs.	220V/60/1	527 lbs.	13758
SS-ES-0052-PAS	2.5 HP	114 lbs.	220V/60/3	610.7 lbs.	13759
SS-IT-0052-PASM	2.5 HP	114 lbs.	220V/60/1	610.7 lbs.	17146

Installation

(Machine should only be installed by a qualified technician and in compliance with local codes).

The electrical installation of the workplace should be equipped with power surge full protection, which should then be adjusted to the technical specifications of your particular unit (see below).

UNPACKING AND POSITIONING

Always keep the machine in a vertical position. Take the machine out of its box. Remove the knee lever (and the upper lid screws for E models) from the inside of the barrel and set them in their proper positions. Do not use the knee lever to move the machine. The machine comes with two fixed (non-castor) wheels in the front and two plastic anti-vibration legs in the back; lift the back part of the machine using the transport handle and move the machine to the desired location (two people are necessary for moving the heavier H42 and H52 models). Do not raise the filler/stuffer too high when moving it since it could tip over, causing personal injury. Place the machine on a level surface. Should the machine wobble, adjust the anti-vibration legs until it is perfectly stable and level. The machine should be placed so that the plug is easily accessible.

IMPORTANT: Remove the protective transport cap on the oil inlet (marked OIL) and replace it with the depressurized oil cap/dipstick enclosed with the machine. Also make sure that the air holes located at the base

Installation

of the barrel are totally clear; if not, the piston will not function properly.

CONNECTING THE MACHINE

Make sure the electrical characteristics of the machine (connection, voltage, and frequency) are suited to your power source. (These specifications are given in detail on the technical specifications sticker affixed to the machine itself; there is a tolerance of $\pm 10\%$ for voltage and of $\pm 2\%$ for frequency). If the specifications are compatible with your power source, refer to the OPERATING INSTRUCTIONS section below. If the electrical features of the machine are not compatible with your power source and your machine is a dual voltage, three-phase unit, adjust the voltage as described below in the CHANGING VOLTAGE section. Once the machine has been installed and the oil level inside the reservoir has been checked using the dipstick attached to the oil inlet screw, check the turning direction of the three-phase motor. If the phases are correctly adjusted, the piston will rise and fall when the knee pedal is pushed. If the phases are incorrect, the pump will not work properly; the motor will make noise, but the piston will not move. Stop immediately and interchange two of the three phases in the plug. Make sure that the plug and outlet are appropriate for the machine.

IMPORTANT: the wiring in the electrical cord is normally assigned as follows: Phase(s): • Black, Brown, Gray • Ground wire: Two-colored Yellow/Green or Green. Check the wiring before connecting; call a qualified electrician if the electrical specifications do not correspond with your power source.

HYDRAULIC OIL FILLING

The H filler/stuffer is delivered with hydraulic oil already in the internal reservoir; therefore, the initial addition of oil to the hydraulic system is usually unnecessary. In the exceptional case that a machine is delivered without hydraulic oil in the reservoir, do not turn it on. Fill the reservoir as follows:

- Remove the oil reservoir screw (marked OIL) located in the upper part of the base.
- Check that the correct level of oil is inside the reservoir by using the dipstick (with max./min. marks) attached to the oil reservoir cap.
- Using a funnel, pour the hydraulic oil into the tank. Do not fill the reservoir to the top since a certain amount of air must remain in the reservoir to allow for expansion. Use oils for medium pressure hydraulic assemblages (approx. 100 bar), and of a viscosity of approximately 5° Engler (equivalent to ISO3498: cat HL VG46 or DIN8659: HL-46). After filling the reservoir, raise and lower the piston several times to purge any remaining air from the hydraulic circuit.

Always fill the reservoir to the maximum level without exceeding it since the more oil there is in the reservoir, the more effectively the heat given off by the hydraulic assemblage will be cooled. This helps lengthen the life of the oil. Because there should be no loss of oil or oil vapors, an adequate level of hydraulic oil should last several years (between 2500 and 5000 hours of use), making it unnecessary to check the oil level as long as the machine is functioning well. For more information, see the MAINTENANCE section below.

CHANGING THE VOLTAGE

IMPORTANT: Only for three-phase machines with dual voltage motor 380/220 Volt (400/230 Volt for EU), etc. This operation should only be carried out by a qualified electrician. Do not connect the machine to the power source. If already plugged in, unplug it and leave it disconnected for the entire process. Remove the screws from the steel lid on the base. Remove the lid.

Installation

CHANGING THE VOLTAGE ON A MODELS (AUTOMATIC-CONTACTOR)

MOTOR: Open the connection terminal box of the motor by unscrewing the four screws. Loosen the six small nuts on the connection terminals and place the plates in the correct position.

CONTACTOR: will need to be replaced by a qualified technician to a new one of same voltage than power supply.

CHANGING THE VOLTAGE ON “I” MODELS (SWITCH)

MOTOR: Open the connection terminal box of the motor by unscrewing the four screws. Loosen the six small nuts on the connection terminals and place the plates in the correct position.

Operation

IMPORTANT: Before operating the unit, read this manual thoroughly. Test the machine when it is empty before using it on food.

HANDLING STEPS

- Loosen the screws on the upper lid (only for E models) and open the lid with a slight upward motion to reduce friction.
- Wash the meat barrel, the underside of the lid, and the appropriate nozzle with hot water.
- Lower the pressure of the machine to the minimum by turning the red knob that regulates the filling speed counter-clockwise.
- Plug the machine in.
- Turn the gray switch located on the right of the machine to the “I” (start) position (I models only).
- Turn the machine on by pushing the knee lever.
- Push the knee lever all the way back to lower the piston enough to make room for the desired amount of mixture.
- Place the mixture in the meat barrel, pressing each new load of mixture down to avoid the formation of air pockets which could break the casing during the filling process.
- Put the green lid gasket in place.
- Using the knee pedal, raise the piston until the mixture reaches the top of the barrel.
- Using food fat or another USDA approved shortening, grease the upper part of the lid gasket and the underside of the lid.
- Carefully close the lid with a light lifting movement to avoid friction, taking care not to pinch or crimp the cover gasket in the process.

To close the lid, use only the lever incorporated in the lid itself; do not use the nozzle. Take extreme care not to trap or pinch your hands while closing the lid.

- After putting the screws back on the upper lid (E models only), place the optimum-size nozzle (largest

Operation

diameter and shortest length possible) on the lid, locking it in place by turning the triangular nozzle nut. Prepare the proper amount of casing.

- Push the knee lever all the way forward to the piston raising position. Always push the knee lever firmly; do not use it as a speed control regulator.
- Carefully raise the pressure by slowly turning the pressure control knob clockwise. Do not raise the pressure suddenly, as this could cause the mixture to come out of the nozzle too quickly.
- Note how the piston will begin to rise and air will come out of the nozzle.
- Once the mixture begins to come out of the nozzle, release the pressure and place the casing on the nozzle. Adjust the red pressure control knob to select the optimum speed.
- Once the casing has been filled, push the knee lever back to the piston lowering position until the piston is at its lowest level in the barrel.
- To stop the hydraulic assemblage, bring the knee pedal to the central position.
- Turn the gray switch located on the right of the machine to the "O" (stop) position (I models only).
- When finished using the machine, clean it, lower the piston to its lowest position in the barrel, unplug the machine and make sure that the machine cannot roll.

USEFUL TIPS

- Do not use the machine without having received previous instructions from an experienced operator.
- This instruction manual should be read carefully and fully understood before using the machine.
- Test the machine when it is empty before using it on food.

Observe all the appropriate hygiene measures when handling food products; use adequate protective equipment and procedures (washing, gloves, cap, apron, etc.). To produce sausage with a better appearance and less smearing, as well as for more uniform mixture and less wear and tear on the machine, we recommend the use of:

- Horn with the largest diameter and shortest length possible.
- Finely chopped mixtures at the least coldest temperature possible.

Consequently, we recommend avoiding very long nozzles or nozzles with small diameters when using roughly chopped or very cold mixtures. If nozzles of special dimensions are needed, order them from your dealer. Never use the nozzle to close the lid since the rim could break. Close the lid with the lid lever only. Do not open or close the lid without the green gasket in place since this could lead to scratches on the lid and clamp. The barrel lid cannot be opened without first slightly lowering the piston by placing the knee pedal in the down position. This will stop the mixture from blocking the opening. Place the machine as close to the work surface as possible. The locations of the nozzle and knee lever allow the nozzle to be located completely over the work surface, thus guaranteeing that no liquid falls onto the floor or the operator. In order to prevent overheating in I models, turn the machine off after use. Turn the motor on only when in use.

Work at a reasonable pace, thus avoiding constant stopping and restarting of the hydraulic assemblage. This machine is not designed to withstand permanent, uninterrupted use at high pressure, but rather to run intermittently with pauses to allow for the dissipation of the heat generated, the amount of which depends on the consistency of the mixture. Because of the pressure transmitted by the pump, after prolonged periods of use the hydraulic oil may reach temperatures of up to 60°C (140°F) and the base side panel may become warm to the touch.

CLEANING

IMPORTANT: In order to avoid mechanical hazards during cleaning operations and piston dismantling, always open the lid completely when raising the piston.

CLEANING INSTRUCTIONS

To clean the outside of the machine use hot water and a mild cleanser. Do not use any abrasive products, especially those that could scratch warning stickers and labels. Never wet or dampen the electrical elements of the machine (switches, cables, etc.). Never use a jet of water to clean any part of the machine, especially the air holes on the side of the oil tank cap. At the end of each workday, the underside of the lid (the mixture exit hole), as well as the nozzle(s) and the nozzle nut should be cleaned thoroughly. If necessary, clean the inside of the nozzles with a round brush. Do not open or close the lid without the green gasket in place since this could scratch the lid and clamp. Using hot water only, rinse the lid bolt and bearing to eliminate any residue that could crystallize (salts, spices, etc.) and thus impede the proper functioning of the lid. The upper part of the black piston gasket should also be cleaned daily, following these steps:

- Open the lid completely and remove the green lid gasket.
- Press the knee lever until the piston rises to its uppermost position. Part of the black piston gasket will now be accessible via the upper part of the barrel. Clean it with a damp cloth.

We recommend that you periodically clean the piston and barrel interior thoroughly:

- Loosen the screws on the upper lid (E models only), open the lid completely and remove the green lid gasket.
- Press the knee lever until the piston rises to its uppermost position.
- With the piston at its highest position, simultaneously push the knee lever and, with the aid of the two pivots of the wrench supplied, unscrew the piston-locking bolt (two turns) located in the center of the piston.
- Screw the wrench completely into the piston hole. The piston will rise above the rim of the barrel.
- Pull the wrench up to remove the piston from the barrel.
- Unplug the machine.
- Clean the inside of the cylinder. Make sure that the bottom of the cylinder is completely DRY to avoid the formation of water droplets, which could eventually lead to the formation of rust on the upper part of the base.

IMPORTANT: Piston and barrel cleaning can also be done by dismantling the removable barrel (E models only); however, to avoid mechanical hazards as well as damage to the piston gaskets, we advise removal of the piston only.

CLEANING PRECAUTIONS

Because of the weight of the piston, use caution when moving it. Clean the piston and the black piston gaskets (1 or 2, depending on the model). To avoid damaging the gaskets, never use sharp or pointed tools (knives, screwdrivers) to remove them. To reduce the noise caused by the movement of the piston, grease the piston gaskets with food fat or another USDA approved shortening before putting them back into the barrel. Never introduce water inside the barrel since it could filter down to the base of the machine and affect the electrical and mechanical components. The holes in the bottom of the barrel are vents for air only.

To reassemble the piston, make sure that the bottom of the barrel is completely dry, then place the piston in the

Maintenance

barrel and screw the piston-locking bolt tight, making sure that the smaller gasket is properly placed. Raise and lower the piston, and tighten the piston locking bolt again, making sure it does not bend against the pressure of the lid. Grease the thread of the piston-locking bolt before replacing it; this will make future dismantling easier. When the machine is not in use, leave the piston head at the bottom of cylinder, where it will be submerged in hydraulic oil. This will lengthen the life of the ram and the gaskets.

GENERAL CLEANING ADVICE

Cleaning steps	Products	Method	Tools	Notes
Superficial cleaning		Manual	Spatula	Remove all residue directly after use, removing smaller machine parts if necessary.
Extensive cleaning	Mild detergent	Manual	Brush, bucket	Leave product to work ± 15 minutes.
Rinsing	Warm water	Manual	Sponge, bucket	Warm water 40/50 ° C - 100/120 ° F.
Inspection				Check critical points and problematic parts.
Disinfecting	Disinfectant products	Manual	Sponge, cleaning cloth	After completing all other cleaning operations.
Rinsing	Drinking water	Manual	Sponge, bucket	
Drying			Cleaning cloth	
Maintenance	Lubricating oil	Manual	Cleaning cloth	External machine parts.

SPECIFIC CLEANING ADVICE

Interval	Cleaning area	Method	Products	Tools	Notes
Daily	Underside of the lid, lid gasket, inside of the barrel and piston bolt retaining screw	Manual	Mild detergent, warm water	Sponge, cleaning cloth	Eliminate dirt from retaining screw using a brush if necessary. Avoid build up of residues.
Bi-Weekly	Piston, piston gaskets and gasket of piston bolt retaining screw	Manual	Mild detergent, warm water	Sponge, cleaning cloth	To remove the piston, follow the instructions above.

These cleaning instructions have been elaborated for companies with just one shift; shorter intervals should be observed in companies with many work groups.

IMPORTANT: Among the parts which should be cleaned daily (see “SPECIFIC CLEAN ADVICE” above), the piston bolt retaining screw must be cleaned thoroughly by dismantling it. In E models, the following parts should also be dismantled for better cleaning: lid closing nuts, lid, barrel. Piston removal: See above.

MAINTENANCE

IMPORTANT: Unplug the machine before proceeding with maintenance and inspection.

Maintenance

During maintenance and inspection operations always follow the safety instructions in this manual. Mechanical breakdowns caused by inadequate or improper maintenance can lead to high repair costs as well as work stoppages; therefore, regular and adequate maintenance is indispensable. The safety and life of the machine depend on many factors, including proper maintenance. Because different companies have different shift schedules, it is impossible to prescribe in advance how often you should proceed with inspections, maintenance or replacement. Adjust your inspection routine to the number of work groups you have in your company. Our local dealer will be delighted to give you further information. The table below contains information about maintenance and inspection (control intervals, critical points, etc.) for a machine under normal use.

MAINTENANCE AND INSPECTION SCHEDULES

After reading the following, consult the MAINTENANCE AND INSPECTION TIPS section for more details.

Control interval	Critical points / Maintenance information
Daily	Check green lid gasket and replace it if necessary.
	Check the two black piston gaskets and replace them if necessary.
	Check the air holes located at the base of the barrel and clear them of any obstruction.
Monthly	Check the lid closure and tighten if necessary by regulating the lid fixing bolts (P models only).
Yearly	Check hydraulic oil level and refill the reservoir if necessary.
Every 2500-5000 service hours	Change hydraulic oil.
	Check oil filter and replace it if necessary.

MAINTENANCE AND INSPECTION TIPS

Green lid gasket: Replace if damaged or if leaks are observed. This gasket is reversible, i.e. it can be used with either side facing up. A spare gasket comes with the machine. The gasket is made from a non-toxic material that is safe for alimentary use. Place the glued joint of the gasket under the lid bolt. To reduce lid friction and extend lid gasket life, before closing always grease the green gasket and the lower part of the lid with animal fat or another USDA approved.

Black piston gasket: Replace if damaged or if leaks are observed. To reduce noise caused by the movement of the piston, grease this gasket with animal fat or another USDA approved shortening before placing it in the barrel.

Hydraulic oil level: The oil level can be tested with the dipstick provided on the oil inlet screw. Always fill the reservoir to the maximum level marked without exceeding it since the more oil there is in the reservoir, the more effectively the heat given off by the hydraulic assemblage will be cooled. This helps lengthen the life of the oil.

Hydraulic oil duration: The life of hydraulic oil varies depending on many factors, e.g. temperature and

Maintenance

pressure at which the machine is run, the presence of humidity or residual water, etc. Normally it can last between 2.500 and 5.000 hours of service. If the oil loses viscosity, becomes impure, or turns a whitish color from having had water pumped into it, drain the oil by emptying the housing via the plug located at the bottom of the machine. Refill the oil following the instructions found in the INSTALLATION section above. Because there is no natural loss of oil or oil vapors, an adequate level of hydraulic oil should last several years, making it unnecessary to check the oil level regularly. If the oil level is insufficient, the piston will not move smoothly, since air will be entering the circuit.

Changing the hydraulic oil: Remove the oil outlet plug located at the bottom of the base and drain the reservoir, emptying the oil into an appropriate recipient (please recycle used oil). Replace the plug and seal the oil outlet site hermetically. Using a funnel, fill the reservoir with 10 liters (for H15/H20 models), 15 liters (for H26/H31 models) or 25 liters (for H42/H52 models) of hydraulic oil via the tank opening. Do not fill the reservoir to the top since a certain amount of air must be present to allow for expansion. Use oils for medium pressure hydraulic assemblages (approx. 100 bar), and of a viscosity of approximately 5° Engler (equivalent to ISO3498: cat HL VG46 or DIN8659: HL-46). After filling the reservoir, raise and lower the piston several times to eliminate air pockets from the hydraulic circuit.

Oil filter: Located inside the oil reservoir, the oil filter is not accessible to the user and should only be replaced by a qualified technician. To remove the oil filter remove the two screws that attach the closing clamp to the filter and pull the filter outward. Normally, the filter should not become dirty or present any abnormality. If the filter must be changed, use a similar filter with a thread of 3/8" BSP and a filtering capacity of 10 liters per minute, (5 liters per minute for H15/H20). After reassembling the unit, the closing clamp must be sealed hermetically.

Oil temperature: Because of the pressure transmitted by the pump, after prolonged periods of use the hydraulic oil may reach temperatures of up to 60°C (140°F) and the base side panel may become warm to the touch. This machine is not designed to withstand permanent, uninterrupted use at high pressure, but rather to run intermittently with pauses to allow for the dissipation of the heat generated, the amount of which depends on the consistency of the mixture.

Cylinder ram: In order to lengthen the life of the hydraulic cylinder ram, leave the piston head at the bottom of the cylinder when the machine is not in use. The ram will thus be completely submerged in hydraulic oil.

Lid closure: The lid of the barrel can be shut more or less tightly depending on how watertight the closure should be. If the mixture is customarily dry, the closure can be loosened, making it easier to close the lid. If, however, the mixture contains more liquid, the closure should be tighter to avoid leaks. To loosen the lid in E models, loosen the upper lid screws until the desired seal is obtained. For P models, loosen the nuts located beneath the clamp and either loosen or tighten the 2 lid fixing bolts. Then retighten the 2 lock nuts completely. To keep crystallized residue (from salts, spices, etc.) from impeding the proper closure of the lid, remember to rinse the lid bolt and bearing with hot water after using the machine.

Lack of power: If the machine seems to lack power, notify the service department of the dealer where the machine was purchased. They should verify the following points: that the air holes located at the base of the barrel are completely free of obstruction, that the piston and the piston gaskets are perfectly clean and free of residue which could inhibit the movement of the piston, that the voltage of the power source is compatible

Maintenance

with that selected for the motor, that the motor is not functioning with only two phases, that there is enough hydraulic oil, that there is no oil leakage from the hydraulic screws or pipes, and that the oil filter is clean and unobstructed.

Electrical cord: If the electrical cord becomes damaged, have it replaced immediately with a cord of identical technical characteristics (your local distributor can supply you with one).

Spare parts: To order spare parts, contact the dealer where the machine was purchased. Be sure to give full details when identifying the machine (model, serial number, year of manufacture, power, voltage, frequency, etc.). This data can be found on the technical specifications plate located on the machine itself.

Troubleshooting

Problems	Possible Causes	Solutions
Machine does not work.	Machine is unplugged.	Plug the machine in.
	Machine connected to a lower voltage.	Change machine voltage.
	No voltage in one or more phases.	Check fuses, plugs, and switches.
	Switch located on the right of the machine is in 0-stop position (I models only).	Turn the switch to 1-start position.
	0-1 switch (I models only) is defective.	Call an electrician.
	Internal on/off microswitch in knee lever is defective or not properly adjusted (A models only).	Call an electrician to replace or adjust the microswitch.
Electric motor runs, but the piston does not move up or down.	Speed regulator on minimum.	Turn speed regulator knob clockwise.
	Motor is turning in the wrong direction.	Interchange two of the three phases in the plug.

Troubleshooting

Piston moves up and down but machine seems to lack power.	The air holes located at the base of the barrel are obstructed.	Clean air holes.
	Piston and piston gaskets are dirty.	Clean piston and piston gaskets.
	Voltage of power source is not compatible with voltage selected for the motor.	Call an electrician to change motor voltage.
	Three-phase motor (if available) is only functioning with two phases.	Adjust phases at the power source.
	Lack of hydraulic oil.	Fill the oil reservoir to the "MAX." mark.
	Oil leakage from hydraulic screws or pipes.	Call your local dealer.
	Oil filter is dirty.	Call your local dealer to replace it.

Parts Breakdown

Model SS-ES-0015-PA 13743
Model SS-ES-0015-PAM 13744
Model SS-ES-0015-PAM 41708
Model SS-ES-0020-PA 13745
Model SS-ES-0020-PAM 13746
Model SS-ES-0026-PA 13750
Model SS-ES-0026-PAM 13751
Model SS-ES-0026-PAS 13752

Model SS-ES-0026-PASM 13753
Model SS-ES-0026-PASM 41709
Model SS-ES-0031-PAS 13755
Model SS-ES-0031-PASM 13756
Model SS-ES-0042-PAS 13757
Model SS-ES-0042-PASM 13758
Model SS-ES-0052-PAS 13759
Model SS-ES-0052-PASM 17146

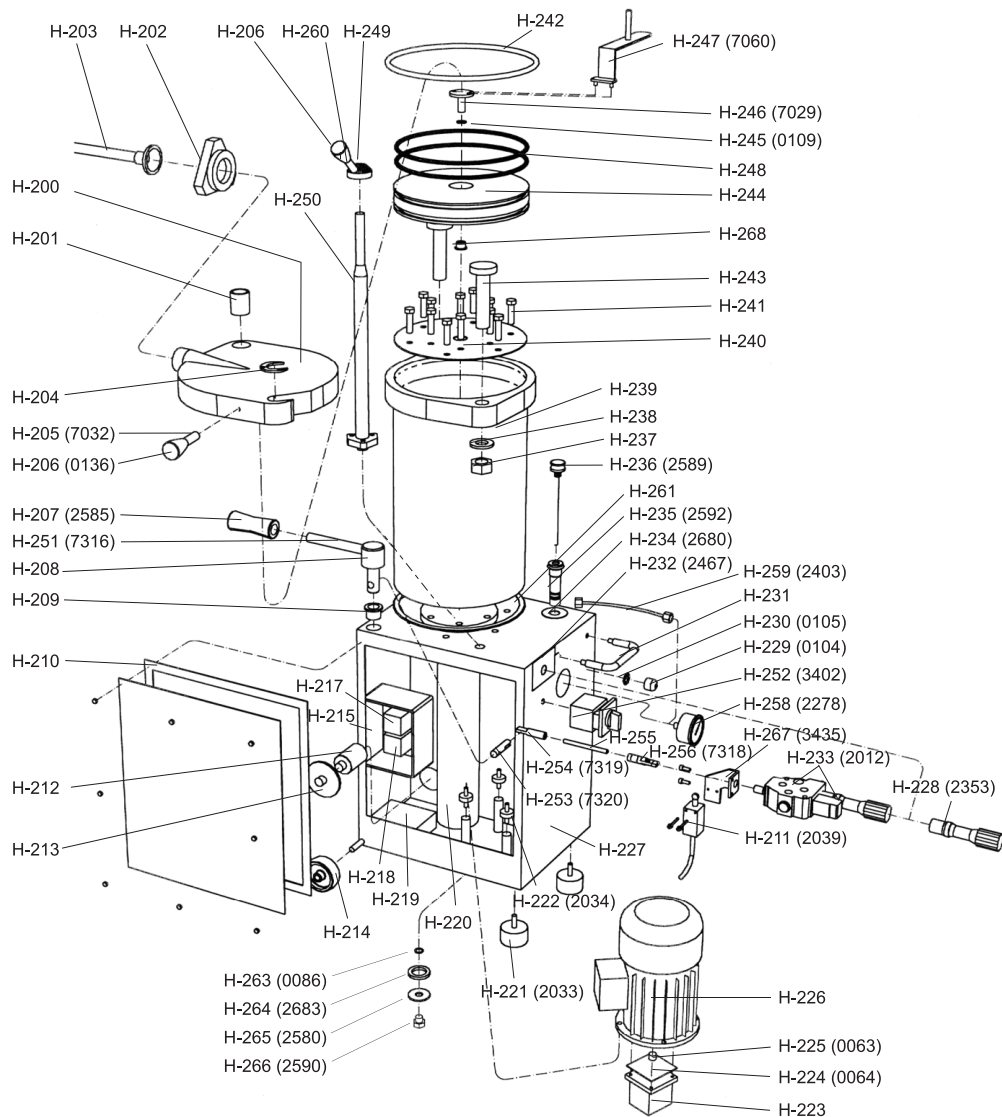

Parts Breakdown

Model SS-ES-0015-PA 13743

Model SS-ES-0015-PAM 13744/41708

Item No.	Description	Position	Item No.	Description	Position	Item No.	Description	Position
36005	Aluminum Lid for H15	H200	19253	Black Rubber Anti-Vibration Motor Support for H15	H222	36068	Aluminum Piston for H15	H244
36005	Aluminum Lid for H15	H200	64313	Hydraulic Pump for H15	H223	36064	Piston Locking Bolt O-Ring for H15	H245
36111	Plastic Bearing for Aluminum Lid E - Removable Barrel Model for H15	H201	31221	Motor-Pump Gasket for H15	H224	16538	Piston Lock Bolt Screw for H15	H246
36013	Bronze Bearing for Aluminum Lid P-Fixed Barrel Model for H15	H201	31222	Motor-Pump Coupling for H15	H225	16543	Piston Removing Wrench with Screw for H15	H247
16542	Aluminum Horn/Nozzle Locking Nut, Open Slot for H15	H202	76772	Electric Motor for H15	H226	16533	Piston O-Ring (Package of 4/2 Units) for H15	H248
76770	Horn/Nozzle, all Stainless Steel for H15	H203	76773	Machine Frame for H15	H227	36061	Lid Closing Nut (only E Models) for H15	H249
36034	Stainless Steel Horseshoe for Aluminum Lid E Model for H15	H204	31219	Red Knob and Shaft Only (Pressure Control) for H15	H228	36098	Lateral Barrel Bar (only E Models) for H15	H250
36035	Stainless Steel Horseshoe for Aluminum Lid P Model for H15	H204	36030	Supply Cord Grommet for H15	H229	19237	Horizontal Stainless Steel Knee Lever Axle for H15	H251
16539	Lid Lever without Green Plastic Knob for H15	H205	36044	Grommet Nut for H15	H230	36100	Manual Switch 0-1 with Black Knob (only I Models) for H15	H252
16517	Green Plastic Ital Knob for Lid Lever for H15	H206	36031	Stainless Steel Transport Handle for H15	H231	16548	Fork Knee Lever for H15	H253
19238	Green Rubber Knee Lever for H15	H207	36074	Plastic Pressure Control Label for H15	H232	16547	Knee Lever Bar for H15	H254
16549	Vertical Knee Lever Shaft P-Model, Stainless Steel for H15	H208	16522	Complete Hydraulic Direct Control Valve for H15	H233	36101	Knee Lever Thread M8 for H15	H255
16550	Vertical Knee Lever Shaft E Stainless Steel for H15	H208	36022	Oil Input Label for H15	H234	19415	Hydraulic Control Action Bar for H15	H256
16551	Knee Lever Bronze Bearing for H15	H209	16527	Green Plastic Oil Input Tube for H15	H235	16525	Pressure Gauge P for H15	H258
19239	Knee Lever Bronze Bearing for H15	H209	16526	Plastic Oil Drain Plug with Level Bar for H15	H236	36036	Pressure Gauge Hose for H15	H259
36093	Green Rubber Gasket Panel for H15	H210	36080	Stainless Steel Hex Nut for Lid Bolt (P Models only) for H15	H237	36043	Lid Closing Nut Lever without Green Knob, E Models only for H15	H260
16524	Internal Crouzet Micro-Switch (only A-Automatic Models) for H15	H211	36107	Stainless Steel Washer for Lid Bolt (P Models only) for H15	H238	36018	Inferior Circular Barrel Rubber Gasket Green (only for P Models) for H15	H261
16523	Oil Filter for H15	H212	36023	Fixed P Meat Barrel for H15	H239	36106	Hydraulic Metal-Plastic Washer 3/8", Emptying for H15	H263
23808	Oil Filter Cover for H15	H213	36075	Removable E Meat Barrel for H15	H239	23809	Plane Black Rubber Washer, Emptying for H15	H264
19416	Green Plastic Wheel for H15	H214	36008	Stainless Steel Barrel Bottom Protection Disc (P Models only) for H15	H240	23810	Special Plane Stainless Steel Rubber, Emptying for H15	H265
36042	Plastic Electric Switchboard Box for H15	H215	36032	Stainless Steel Barrel Bottom Protection Hat (E Models only) for H15	H240	36062	Oil Emptying Plug for H15	H266
76771	Contacteur Telemecanique for H15	H217	31223	Stainless Steel Fixing Screw for H15	H241	36037	Micro Switch Holder (only for P Models) for H15	H267
39059	Air Extraction Fan for H15	H219	16530	Lid Gasket for P Models Barrel only (Package of 3) for H15	H242	21584	Ring, Threaded Aluminum Piston for H15	H268
36038	Complete Hydraulic Cylinder for H15	H220	36067	Green Rubber Rectangular Lid Gasket for E Models Removable Barrel only (Package of 3) for H15	H242			
27879	Green Rubber Anti-Vibration Foot for H15	H221	36077	Stainless Steel Lid Bolt Models HP for H15	H243			

Parts Breakdown

Model SS-ES-0020-PA 13745

Model SS-ES-0020-PAM 13746

Item No.	Description	Position	Item No.	Description	Position	Item No.	Description	Position
36005	Aluminum Lid (only P Models) for H20	H200	64314	Hydraulic Pump for H20	H223	36068	Aluminum Piston for H20	H244
36013	Bronze Bearing for Aluminum Lid P-Fixed Barrel Model for H20	H201	31221	Motor-Pump Gasket for H20	H224	36064	Piston Locking Bolt O-Ring for H20	H245
16542	Aluminum Horn/Nozzle Locking Nut, Open Slot for H20	H202	31222	Motor-Pump Coupling for H20	H225	16538	Piston Lock Bolt Screw for H20	H246
76776	Horn/Nozzle, all Stainless Steel for H20	H203	76781	Electric Motor for H20	H226	16543	Piston Removing Wrench with Screw for H20	H247
36035	Stainless Steel Horseshoe for Aluminum Lid P Model for H20	H204	76782	Machine Frame for H20	H227	16533	Piston O-Ring (Package of 4/2 Units) for H20	H248
16539	Lid Lever without Green Plastic Knob for H20	H205	31219	Red Knob and Shaft Only (Pressure Control) for H20	H228	19237	Horizontal Stainless Steel Knee Lever Axle for H20	H251
16517	Green Plastic Ital Knob for Lid Lever for H20	H206	36030	Supply Cord Grommet for H20	H229	36100	Manual Switch 0-1 with Black Knob (only I Models) for H20	H252
19238	Green Rubber Knee Lever for H20	H207	36044	Grommet Nut for H20	H230	16548	Fork Knee Lever for H20	H253
16549	Vertical Knee Lever Shaft P-Model, Stainless Steel for H20	H208	36031	Stainless Steel Transport Handle for H20	H231	16547	Knee Lever Bar for H20	H254
16551	Knee Lever Bronze Bearing for H20	H209	36074	Plastic Pressure Control Label for H20	H232	36101	Knee Lever Thread M8 for H20	H255
36094	Green Rubber Gasket Panel for H20	H210	16522	Complete Hydraulic Direct Control Valve for H20	H233	19415	Hydraulic Control Action Bar for H20	H256
16524	Internal Crouzet Micro-Switch (only A-Automatic Models) for H20	H211	36022	Oil Input Label for H20	H234	16525	Pressure Gauge P for H20	H258
16523	Oil Filter for H20	H212	16527	Green Plastic Oil Input Tube for H20	H235	36036	Pressure Gauge Hose for H20	H259
23808	Oil Filter Cover for H20	H213	16526	Plastic Oil Drain Plug with Level Bar for H20	H236	36018	Inferior Circular Barrel Rubber Gasket Green (only for P Models) for H20	H261
19416	Green Plastic Wheel for H20	H214	36080	Stainless Steel Hex Nut for Lid Bolt (P Models only) for H20	H237	36106	Hydraulic Metal-Plastic Washer 3/8", Emptying for H20	H263
36042	Plastic Electric Switchboard Box for H20	H215	36107	Stainless Steel Washer for Lid Bolt (P Models only) for H20	H238	23809	Plane Black Rubber Washer, Emptying for H20	H264
76778	Contacteur Telemecanique for H20	H217	36024	Fixed P Meat Barrel for H20	H239	23810	Special Plane Stainless Steel Rubber, Emptying for H20	H265
76779	Air Extraction Fan for H20	H219	36008	Stainless Steel Barrel Bottom Protection Disc (P Models only) for H20	H240	36062	Oil Emptying Plug for H20	H266
36039	Complete Hydraulic Cylinder for H20	H220	31223	Stainless Steel Fixing Screw for H20	H241	36037	Micro Switch Holder (only for P Models) for H20	H267
27879	Green Rubber Anti-Vibration Foot for H20	H221	16530	Lid Gasket for P Models Barrel only (Package of 3) for H20	H242	21584	Ring, Threaded Aluminum Piston for H20	H268
19253	Black Rubber Anti-Vibration Motor Support for H20	H222	36077	Stainless Steel Lid Bolt Models HP for H20	H243			

Parts Breakdown

Model SS-ES-0026-PA 13750

Model SS-ES-0026-PAS 13752

Model SS-ES-0026-PAM 13751

Model SS-ES-0026-PASM 13753/41709

Item No.	Description	Position	Item No.	Description	Position	Item No.	Description	Position
16536	Aluminum Lid (only P Models) for H26	H200	76787	Complete Hydraulic Cylinder for H26	H220	36078 16540	Stainless Steel Lid Bolt Models HP for H26	H243
36003	Aluminum Lid (only E Models) for H26	H200	27879	Green Rubber Anti-Vibration Foot for H26	H221	31263	Aluminum Piston for H26	H244
36084	Stainless Steel Lid for H26	H200	19253	Black Rubber Anti-Vibration Motor Support for H26	H222	36069	Stainless Steel Piston for H26	H244
19414	Plastic Bearing for Aluminum Lid E - Removable Barrel Model for H26	H201	18285	Hydraulic Pump for H26	H223	36064	Piston Locking Bolt O-Ring for H26	H245
19409	Bronze Bearing for Aluminum Lid P-Fixed Barrel Model for H26	H201	31221	Motor-Pump Gasket for H26	H224	16538	Piston Lock Bolt Screw for H26	H246
36014	Bronze Bearing for Stainless Steel Lid P - Fixed Barrel Model for H26	H201	31222	Motor-Pump Coupling for H26	H225	16543	Piston Removing Wrench with Screw for H26	H247
16542	Aluminum Horn/Nozzle Locking Nut, Open Slot for H26	H202	76788	Electric Motor for H26	H226	16534	Piston O-Ring (Package of 4/2 Units) for H26	H248
31460	Stainless Steel Horn/Nozzle Locking Nut, without Slot for H26	H202	76789	Machine Frame for H26	H227	36061	Lid Closing Nut (only E Models) for H26	H249
76784	Horn/Nozzle, all Stainless Steel for H26	H203	31219	Red Knob and Shaft Only (Pressure Control) for H26	H228	36099	Lateral Barrel Bar (only E Models) for H26	H250
36034	Stainless Steel Horseshoe for Aluminum Lid E Model for H26	H204	36030	Supply Cord Grommet for H26	H229	19237	Horizontal Stainless Steel Knee Lever Axle for H26	H251
36035	Stainless Steel Horseshoe for Aluminum Lid P Model for H26	H204	36044	Grommet Nut for H26	H230	36100	Manual Switch 0-1 with Black Knob (only I Models) for H26	H252
16539	Lid Lever without Green Plastic Knob for H26	H205	36031	Stainless Steel Transport Handle for H26	H231	16548	Fork Knee Lever for H26	H253
16517	Green Plastic Ital Knob for Lid Lever for H26	H206	36074	Plastic Pressure Control Label for H26	H232	16547	Knee Lever Bar for H26	H254
19238	Green Rubber Knee Lever for H26	H207	16522	Complete Hydraulic Direct Control Valve for H26	H233	36102	Knee Lever Thread M8 for H26	H255
16549	Vertical Knee Lever Shaft P-Model, Stainless Steel for H26	H208	36022	Oil Input Label for H26	H234	19415	Hydraulic Control Action Bar for H26	H256
16550	Vertical Knee Lever Shaft E Stainless Steel for H26	H208	16527	Green Plastic Oil Input Tube for H26	H235	16525	Pressure Gauge P for H26	H258
16551	Knee Lever Bronze Bearing for H26	H209	16526	Plastic Oil Drain Plug with Level Bar for H26	H236	36036	Pressure Gauge Hose for H26	H259
19239	Knee Lever Bronze Bearing for H26	H209	36081	Stainless Steel Hex Nut for Lid Bolt (P Models only) for H26	H237	36043	Lid Closing Nut Lever without Green Knob, E Models only for H26	H260
31220	Green Rubber Gasket Panel for H26	H210	36108	Stainless Steel Washer for Lid Bolt (P Models only) for H26	H238	18230	Inferior Circular Barrel Rubber Gasket Green (only for P Models) for H26	H261
16524	Internal Crouzet Micro-Switch (only A-Automatic Models) for H26	H211	27876	Fixed P Meat Barrel for H26	H239	36106	Hydraulic Metal-Plastic Washer 3/8", Emptying for H26	H263
19411	Oil Filter for H26	H212	36076	Removable E Meat Barrel for H26	H239	23809	Plane Black Rubber Washer, Emptying for H26	H264
23808	Oil Filter Cover for H26	H213	36009	Stainless Steel Barrel Bottom Protection Disc (P Models only) for H26	H240	23810	Special Plane Stainless Steel Rubber, Emptying for H26	H265
19416	Green Plastic Wheel for H26	H214	36033	Stainless Steel Barrel Bottom Protection Hat (E Models only) for H26	H240	36062	Oil Emptying Plug for H26	H266
36042	Plastic Electric Switchboard Box for H26	H215	31223	Stainless Steel Fixing Screw for H26	H241	36037	Micro Switch Holder (only for P Models) for H26	H267
76786	Contacteur Telemecanique for H26	H217	36090	Lid Gasket for P Models Barrel only (Package of 3) for H26	H242	21584	Ring, Threaded Aluminum Piston for H26	H268
39059	Air Extraction Fan for H26	H219	36090	Green Rubber Rectangular Lid Gasket for E Models Removable Barrel only (Package of 3) for H26	H242			

Parts Breakdown

Model SS-ES-0031-PAS 13755

Model SS-ES-0031-PASM 13756

Item No.	Description	Position	Item No.	Description	Position	Item No.	Description	Position
36085	Stainless Steel Lid for H31	H200	18285	Hydraulic Pump for H31	H223	16540	Stainless Steel Lid Bolt Models HP for H31	H243
36015	Bronze Bearing for Stainless Steel Lid P - Fixed Barrel Model for H31	H201	31221	Motor-Pump Gasket for H31	H224	36070	Stainless Steel Piston for H31	H244
31460	Stainless Steel Horn/Nozzle Locking Nut, without Slot for H31	H202	31222	Motor-Pump Coupling for H31	H225	36064	Piston Locking Bolt O-Ring for H31	H245
76791	Horn/Nozzle, all Stainless Steel for H31	H203	76796	Electric Motor for H31	H226	16538	Piston Lock Bolt Screw for H31	H246
16539	Lid Lever without Green Plastic Knob for H31	H205	76797	Machine Frame for H31	H227	16543	Piston Removing Wrench with Screw for H31	H247
16517	Green Plastic Ital Knob for Lid Lever for H31	H206	31219	Red Knob and Shaft Only (Pressure Control) for H31	H228	16528	Piston O-Ring (Package of 4/2 Units) for H31	H248
19238	Green Rubber Knee Lever for H31	H207	36030	Supply Cord Grommet for H31	H229	19237	Horizontal Stainless Steel Knee Lever Axle for H31	H251
16549	Vertical Knee Lever Shaft P-Model, Stainless Steel for H31	H208	36044	Grommet Nut for H31	H230	36100	Manual Switch 0-1 with Black Knob (only I Models) for H31	H252
16551	Knee Lever Bronze Bearing for H31	H209	36031	Stainless Steel Transport Handle for H31	H231	16548	Fork Knee Lever for H31	H253
31220	Green Rubber Gasket Panel for H31	H210	36074	Plastic Pressure Control Label for H31	H232	16547	Knee Lever Bar for H31	H254
16524	Internal Crouzet Micro-Switch (only A-Automatic Models) for H31	H211	16522	Complete Hydraulic Direct Control Valve for H31	H233	36102	Knee Lever Thread M8 for H31	H255
19411	Oil Filter for H31	H212	36022	Oil Input Label for H31	H234	19415	Hydraulic Control Action Bar for H31	H256
23808	Oil Filter Cover for H31	H213	16527	Green Plastic Oil Input Tube for H31	H235	16525	Pressure Gauge P for H31	H258
19416	Green Plastic Wheel for H31	H214	16526	Plastic Oil Drain Plug with Level Bar for H31	H236	36036	Pressure Gauge Hose for H31	H259
36042	Plastic Electric Switchboard Box for H31	H215	36081	Stainless Steel Hex Nut for Lid Bolt (P Models only) for H31	H237	36019	Inferior Circular Barrel Rubber Gasket Green (only for P Models) for H31	H261
76794	Contacteur Telemecanique for H31	H217	36108	Stainless Steel Washer for Lid Bolt (P Models only) for H31	H238	36106	Hydraulic Metal-Plastic Washer 3/8", Emptying for H31	H263
39059	Air Extraction Fan for H31	H219	36025	Fixed P Meat Barrel for H31	H239	23809	Plane Black Rubber Washer, Emptying for H31	H264
76795	Complete Hydraulic Cylinder for H31	H220	36010	Stainless Steel Barrel Bottom Protection Disc (P Models only) for H31	H240	23810	Special Plane Stainless Steel Rubber, Emptying for H31	H265
27879	Green Rubber Anti-Vibration Foot for H31	H221	31223	Stainless Steel Fixing Screw for H31	H241	36062	Oil Emptying Plug for H31	H266
19253	Black Rubber Anti-Vibration Motor Support for H31	H222	16529	Lid Gasket for P Models Barrel only (Package of 3) for H31	H242	36037	Micro Switch Holder (only for P Models) for H31	H267

Parts Breakdown

Model SS-ES-0042-PAS 13757

Model SS-ES-0042-PASM 13758

Item No.	Description	Position	Item No.	Description	Position	Item No.	Description	Position
36086	Stainless Steel Lid for H42	H200	76803	Hydraulic Pump for H42	H223	36079	Stainless Steel Lid Bolt Models HP for H42	H243
36016	Bronze Bearing for Stainless Steel Lid P - Fixed Barrel Model for H42	H201	31221	Motor-Pump Gasket for H42	H224	36071	Stainless Steel Piston for H42	H244
31460	Stainless Steel Horn/Nozzle Locking Nut, without Slot for H42	H202	31222	Motor-Pump Coupling for H42	H225	36064	Piston Locking Bolt O-Ring for H42	H245
76800	Horn/Nozzle, all Stainless Steel for H42	H203	76804	Electric Motor for H42	H226	16538	Piston Lock Bolt Screw for H42	H246
16539	Lid Lever without Green Plastic Knob for H42	H205	76805	Machine Frame for H42	H227	16543	Piston Removing Wrench with Screw for H42	H247
16517	Green Plastic Ital Knob for Lid Lever for H42	H206	31219	Red Knob and Shaft Only (Pressure Control) for H42	H228	16535	Piston O-Ring (Package of 4/2 Units) for H42	H248
19238	Green Rubber Knee Lever for H42	H207	36030	Supply Cord Grommet for H42	H229	19237	Horizontal Stainless Steel Knee Lever Axle for H42	H251
16550	Vertical Knee Lever Shaft E Stainless Steel for H42	H208	36044	Grommet Nut for H42	H230	36100	Manual Switch 0-1 with Black Knob (only I Models) for H42	H252
19239	Knee Lever Bronze Bearing for H42	H209	36088	Stainless Steel Transport Handle for H42	H231	16548	Fork Knee Lever for H42	H253
36095	Green Rubber Gasket Panel for H42	H210	36074	Plastic Pressure Control Label for H42	H232	16547	Knee Lever Bar for H42	H254
16524	Internal Crouzet Micro-Switch (only A-Automatic Models) for H42	H211	16522	Complete Hydraulic Direct Control Valve for H42	H233	36104	Knee Lever Thread M8 for H42	H255
19411	Oil Filter for H42	H212	36022	Oil Input Label for H42	H234	19415	Hydraulic Control Action Bar for H42	H256
23808	Oil Filter Cover for H42	H213	16527	Green Plastic Oil Input Tube for H42	H235	16525	Pressure Gauge P for H42	H258
36110	Green Plastic Wheel for H42	H214	16526	Plastic Oil Drain Plug with Level Bar for H42	H236	36036	Pressure Gauge Hose for H42	H259
36042	Plastic Electric Switchboard Box for H42	H215	36082	Stainless Steel Hex Nut for Lid Bolt (P Models only) for H42	H237	36020	Inferior Circular Barrel Rubber Gasket Green (only for P Models) for H42	H261
76802	Contacteur Telemecanique for H42	H217	36109	Stainless Steel Washer for Lid Bolt (P Models only) for H42	H238	36106	Hydraulic Metal-Plastic Washer 3/8", Emptying for H42	H263
39059	Air Extraction Fan for H42	H219	36026	Fixed P Meat Barrel for H42	H239	23809	Plane Black Rubber Washer, Emptying for H42	H264
36040	Complete Hydraulic Cylinder for H42	H220	64316	Stainless Steel Barrel Bottom Protection Disc (P Models only) for H42	H240	23810	Special Plane Stainless Steel Rubber, Emptying for H42	H265
27880	Green Rubber Anti-Vibration Foot for H42	H221	36083	Stainless Steel Fixing Screw for H42	H241	36062	Oil Emptying Plug for H42	H266
19253	Black Rubber Anti-Vibration Motor Support for H42	H222	16532	Lid Gasket for P Models Barrel only (Package of 3) for H42	H242	36037	Micro Switch Holder (only for P Models) for H42	H267

Parts Breakdown

Model SS-ES-0052-PAS 13759

Model SS-ES-0052-PASM 17146

Item No.	Description	Position	Item No.	Description	Position	Item No.	Description	Position
36087	Stainless Steel Lid for H52	H200	64315	Hydraulic Pump for H52	H223	36079	Stainless Steel Lid Bolt Models HP for H52	H243
36017	Bronze Bearing for Stainless Steel Lid P - Fixed Barrel Model for H52	H201	31221	Motor-Pump Gasket for H52	H224	36072	Stainless Steel Piston for H52	H244
31460	Stainless Steel Horn/Nozzle Locking Nut, without Slot for H52	H202	31222	Motor-Pump Coupling for H52	H225	36064	Piston Locking Bolt O-Ring for H52	H245
76807	Horn/Nozzle, all Stainless Steel for H52	H203	76810	Electric Motor for H52	H226	16538	Piston Lock Bolt Screw for H52	H246
16539	Lid Lever without Green Plastic Knob for H52	H205	76811	Machine Frame for H52	H227	16543	Piston Removing Wrench with Screw for H52	H247
16517	Green Plastic Ital Knob for Lid Lever for H52	H206	31219	Red Knob and Shaft Only (Pressure Control) for H52	H228	19156	Piston O-Ring (Package of 4/2 Units) for H52	H248
19238	Green Rubber Knee Lever for H52	H207	36030	Supply Cord Grommet for H52	H229	19237	Horizontal Stainless Steel Knee Lever Axle for H52	H251
16550	Vertical Knee Lever Shaft E Stainless Steel for H52	H208	36044	Grommet Nut for H52	H230	36100	Manual Switch 0-1 with Black Knob (only I Models) for H52	H252
19239	Knee Lever Bronze Bearing for H52	H209	36088	Stainless Steel Transport Handle for H52	H231	16548	Fork Knee Lever for H52	H253
36092	Green Rubber Gasket Panel for H52	H210	36074	Plastic Pressure Control Label for H52	H232	16547	Knee Lever Bar for H52	H254
16524	Internal Crouzet Micro-Switch (only A-Automatic Models) for H52	H211	16522	Complete Hydraulic Direct Control Valve for H52	H233	36103	Knee Lever Thread M8 for H52	H255
19411	Oil Filter for H52	H212	36022	Oil Input Label for H52	H234	19415	Hydraulic Control Action Bar for H52	H256
23808	Oil Filter Cover for H52	H213	16527	Green Plastic Oil Input Tube for H52	H235	16525	Pressure Gauge P for H52	H258
36110	Green Plastic Wheel for H52	H214	16526	Plastic Oil Drain Plug with Level Bar for H52	H236	36036	Pressure Gauge Hose for H52	H259
36042	Plastic Electric Switchboard Box for H52	H215	36082	Stainless Steel Hex Nut for Lid Bolt (P Models only) for H52	H237	36021	Inferior Circular Barrel Rubber Gasket Green (only for P Models) for H52	H261
76809	Contacteur Telemecanique for H52	H217	36109	Stainless Steel Washer for Lid Bolt (P Models only) for H52	H238	36106	Hydraulic Metal-Plastic Washer 3/8", Emptying for H52	H263
39059	Air Extraction Fan for H52	H219	36027	Fixed P Meat Barrel for H52	H239	23809	Plane Black Rubber Washer, Emptying for H52	H264
36040	Complete Hydraulic Cylinder for H52	H220	36012	Stainless Steel Barrel Bottom Protection Disc (P Models only) for H52	H240	23810	Special Plane Stainless Steel Rubber, Emptying for H52	H265
27880	Green Rubber Anti-Vibration Foot for H52	H221	36083	Stainless Steel Fixing Screw for H52	H241	36062	Oil Emptying Plug for H52	H266
19253	Black Rubber Anti-Vibration Motor Support for H52	H222	19153	Lid Gasket for P Models Barrel only (Package of 3) for H52	H242	36037	Micro Switch Holder (only for P Models) for H52	H267

Electrical Schematics

Model SS-ES-0015-PA 13743

Model SS-ES-0020-PA 13745

Model SS-ES-0026-PA 13750

Model SS-ES-0026-PAS 13752

Model SS-ES-0031-PAS 13755

Model SS-ES-0042-PAS 13757

Model SS-ES-0052-PAS 13759

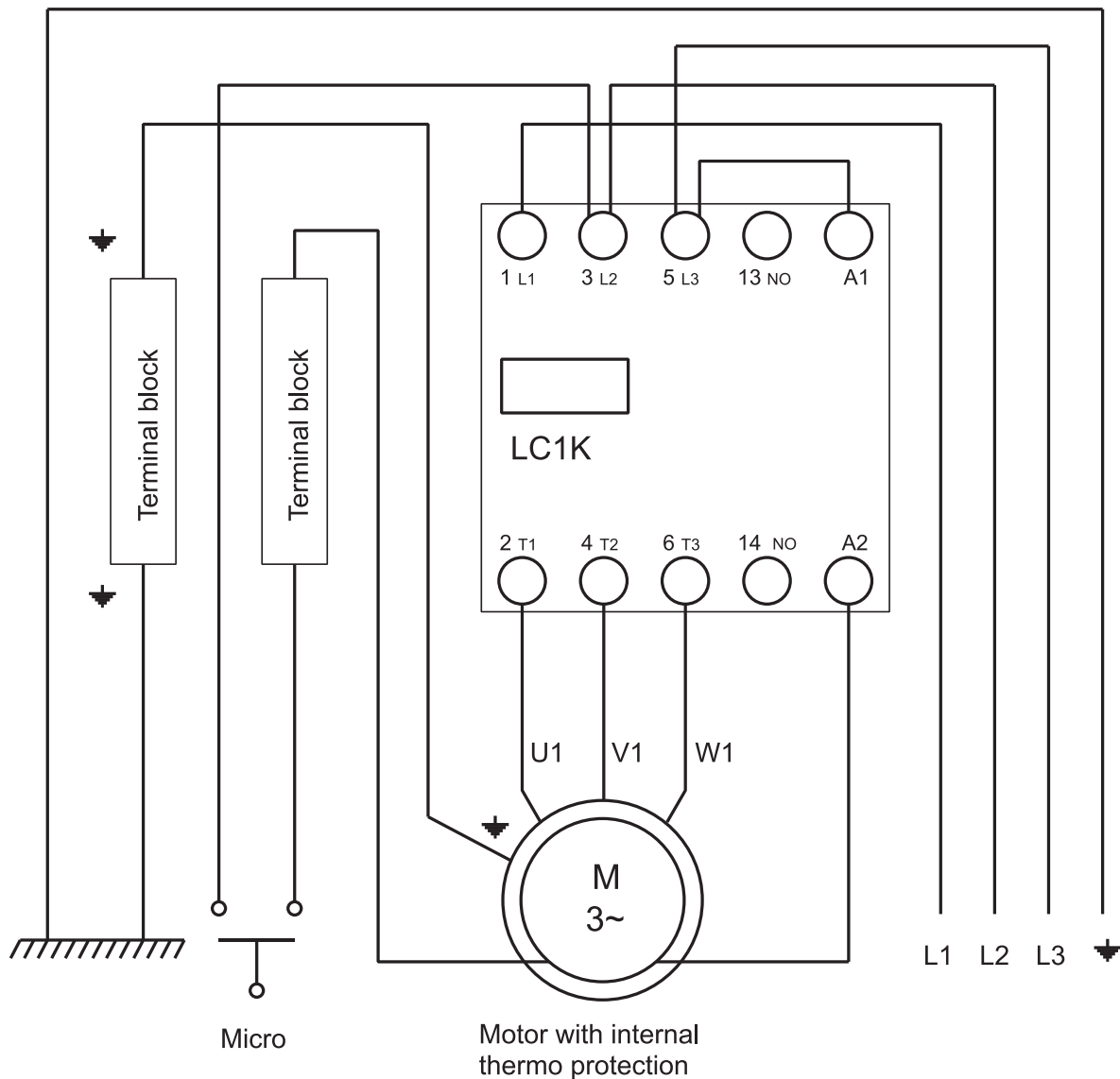

Electrical Schematics

Model SS-ES-0015-PAM 13744/41708

Model SS-ES-0020-PAM 13746

Model SS-ES-0026-PAM 13751

Model SS-ES-0026-PASM 13753/41709

Model SS-ES-0031-PASM 13756

Model SS-ES-0042-PASM 13758

Model SS-ES-0052-PASM 17146

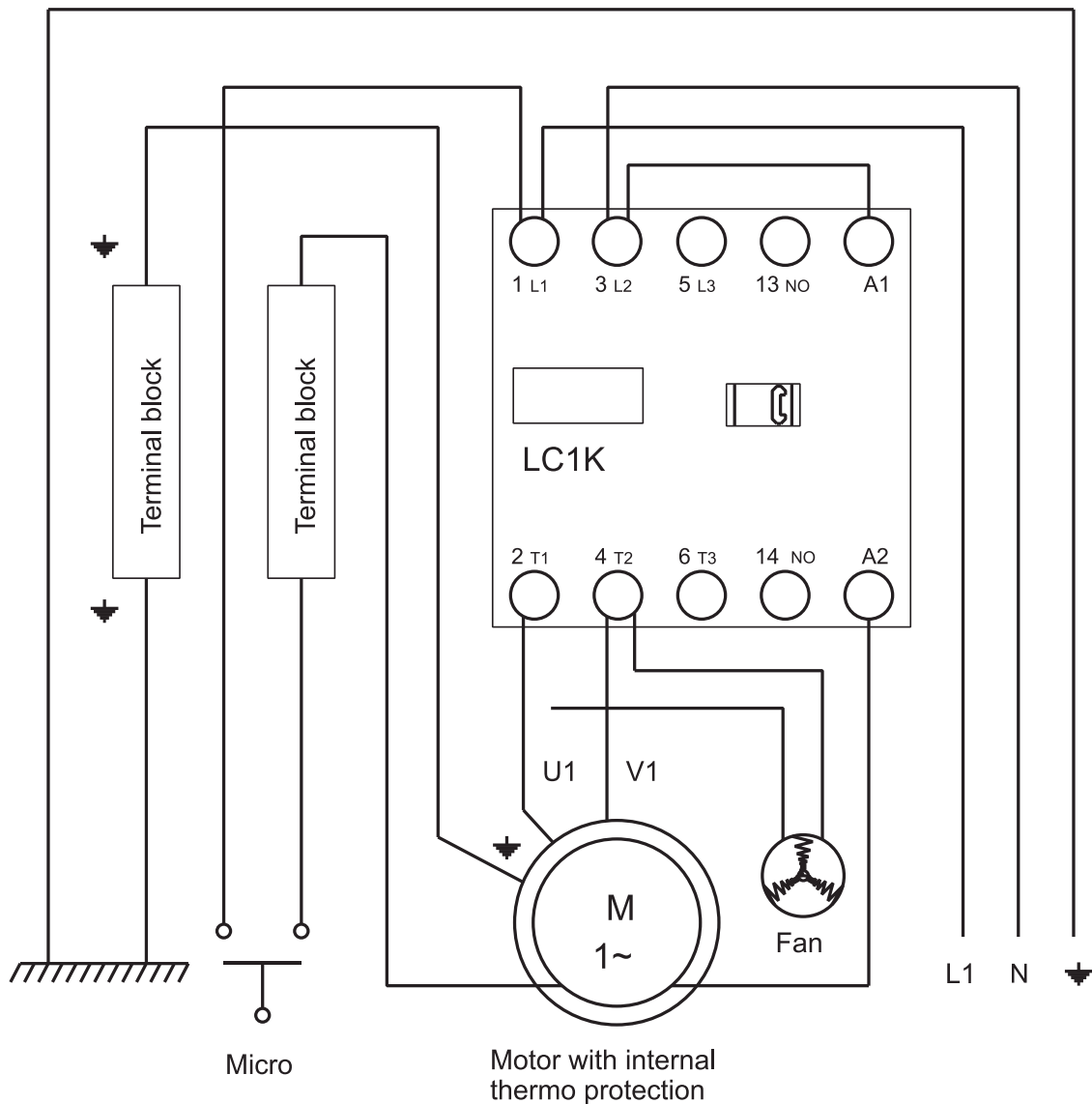



Warranty Registration

Thank you for purchasing an Omcan product. To register your warranty for this product, complete the information below, tear off the card at the perforation and then send to the address specified below. You can also register online by visiting:

Merci d'avoir acheté un produit Omcan. Pour enregistrer votre garantie pour ce produit, complétez les informations ci-dessous, détachez la carte au niveau de la perforation, puis l'envoyer à l'adresse spécifiée ci-dessous. Vous pouvez également vous inscrire en ligne en visitant:

Gracias por comprar un producto Omcan usted. Para registrar su garantía para este producto, complete la información a continuación, cortar la tarjeta en la perforación y luego enviarlo a la dirección indicada a continuación. También puede registrarse en línea en:

www.omcan.com/warrantyregistration.html

For mailing in Canada

Pour postale au Canada

Por correo en Canadá

OMCAN

PRODUCT WARRANTY REGISTRATION

3115 Pepper Mill Court,

Mississauga, Ontario

Canada, L5L 4X5

For mailing in the US

Pour diffusion aux États-Unis

Por correo en los EE.UU.

OMCAN

PRODUCT WARRANTY REGISTRATION

4450 Witmer Industrial Estates, Unit 4,

Niagara Falls, New York

USA, 14305

or email to: service@omcan.com



Purchaser's Information

Name: _____

Company Name: _____

Address: _____

Telephone: _____

City: _____ Province or State: _____ Postal or Zip: _____

Email Address: _____

Country: _____

Type of Company:

Restaurant Bakery Deli

Butcher Supermarket Caterer

Institution (*specify*): _____

Other (*specify*): _____

Dealer from which Purchased: _____

Dealer City: _____ Dealer Province or State: _____

Invoice: _____

Model Name: _____ Model Number: _____

Serial Number: _____

Machine Description: _____

Date of Purchase (MM/DD/YYYY): _____

Date of Installation (MM/DD/YYYY): _____

Would you like to extend the warranty? Yes No

Thank you for choosing Omcan | Merci d'avoir choisi Omcan | Gracias por elegir Omcan



Since 1951 Omcan has grown to become a leading distributor of equipment and supplies to the North American food service industry. Our success over these many years can be attributed to our commitment to strengthen and develop new and existing relationships with our valued customers and manufacturers. Today with partners in North America, Europe, Asia and South America, we continually work to improve and grow the company. We strive to offer customers exceptional value through our qualified local sales and service representatives who provide convenient access to over 3, 500 globally sourced products.

Depuis 1951 Omcan a grandi pour devenir un des “leaders” de la distribution des équipements et matériel pour l’industrie des services alimentaires en Amérique du Nord. Notre succès au cours de ces nombreuses années peut être attribué à notre engagement à renforcer et à développer de nouvelles et existantes relations avec nos clients et les fabricants de valeur. Aujourd’hui avec des partenaires en Amérique du Nord, Europe, Asie et Amérique du Sud, nous travaillons continuellement à améliorer et développer l’entreprise. Nous nous efforçons d’offrir à nos clients une valeur exceptionnelle grâce à nos ventes locales qualifiées et des représentants de service qui offrent un accès facile à plus de 3500 produits provenant du monde entier.

Desde 1951 Omcan ha crecido hasta convertirse en un líder en la distribución de equipos y suministros de alimentos en América del Norte industria de servicios. Nuestro éxito en estos años se puede atribuir a nuestro compromiso de fortalecer y desarrollar nuevas relaciones existentes con nuestros valiosos clientes y fabricantes. Hoy con socios de América del Norte, Europa, Asia y América del Sur, que trabajan continuamente para mejorar y crecer la empresa. Nos esforzamos por ofrecer a nuestros clientes valor excepcional a través de nuestro local de ventas y representantes de los servicios que proporcionan un fácil acceso a más de 3, 500 productos con origen a nivel mundial.

