



INSTALLATION & OPERATION MANUAL FOR GAS RANGES



Models: PT-R24 PT-R36 PT-R60
 PT-R36-24MG-2B PT-R60-24MG
 PT-R60-24CB
 PT-R60-24RG-6B



 **WARNING:** IMPROPER INSTALLATION, ADJUSTMENT, ALTERATION, SERVICE OR MAINTENANCE CAN CAUSE PROPERTY DAMAGE, INJURY OR DEATH. READ THE INSTALLATION, OPERATING AND MAINTENANCE INSTRUCTIONS THOROUGHLY BEFORE INSTALLING OR SERVICING THIS EQUIPMENT.

FOR YOUR SAFETY

DO NOT STORE OR USE GASOLINE OR OTHER FLAMMABLE VAPORS OR LIQUIDS IN THE VICINITY OF THIS OR ANY OTHER APPLIANCE.

| | | |
|---|---|---|
|  | WARNING RISK OF FIRE OR ELECTRIC SHOCK DO NOT OPEN |  |
| <p>WARNING, TO REDUCE THE RISK OF FIRE OR ELECTRIC SHOCK, DO NOT REMOVE COVER (OR BACK) NO USER-SERVICEABLE PARTS INSIDE REPAIR SHOULD BE DONE BY AUTHORIZED SERVICE PERSONNEL ONLY</p> | | |

IMPORTANT FOR YOUR SAFETY

THIS MANUAL HAS BEEN PREPARED FOR PERSONNEL QUALIFIED TO INSTALL GAS EQUIPMENT, WHO SHOULD PERFORM THE INITIAL FIELD START-UP AND ADJUSTMENTS OF THE EQUIPMENT COVERED BY THIS MANUAL.

POST IN A PROMINENT LOCATION THE INSTRUCTIONS TO BE FOLLOWED IN THE EVENT THE SMELL OF GAS IS DETECTED. THIS INFORMATION CAN BE OBTAINED FROM THE LOCAL GAS SUPPLIER.

IMPORTANT

IN THE EVENT A GAS ODOR IS DETECTED, SHUT DOWN UNITS AT MAIN SHUTOFF VALVE AND CONTACT THE LOCAL GAS COMPANY OR GAS SUPPLIER FOR SERVICE.

Dimension of Overall

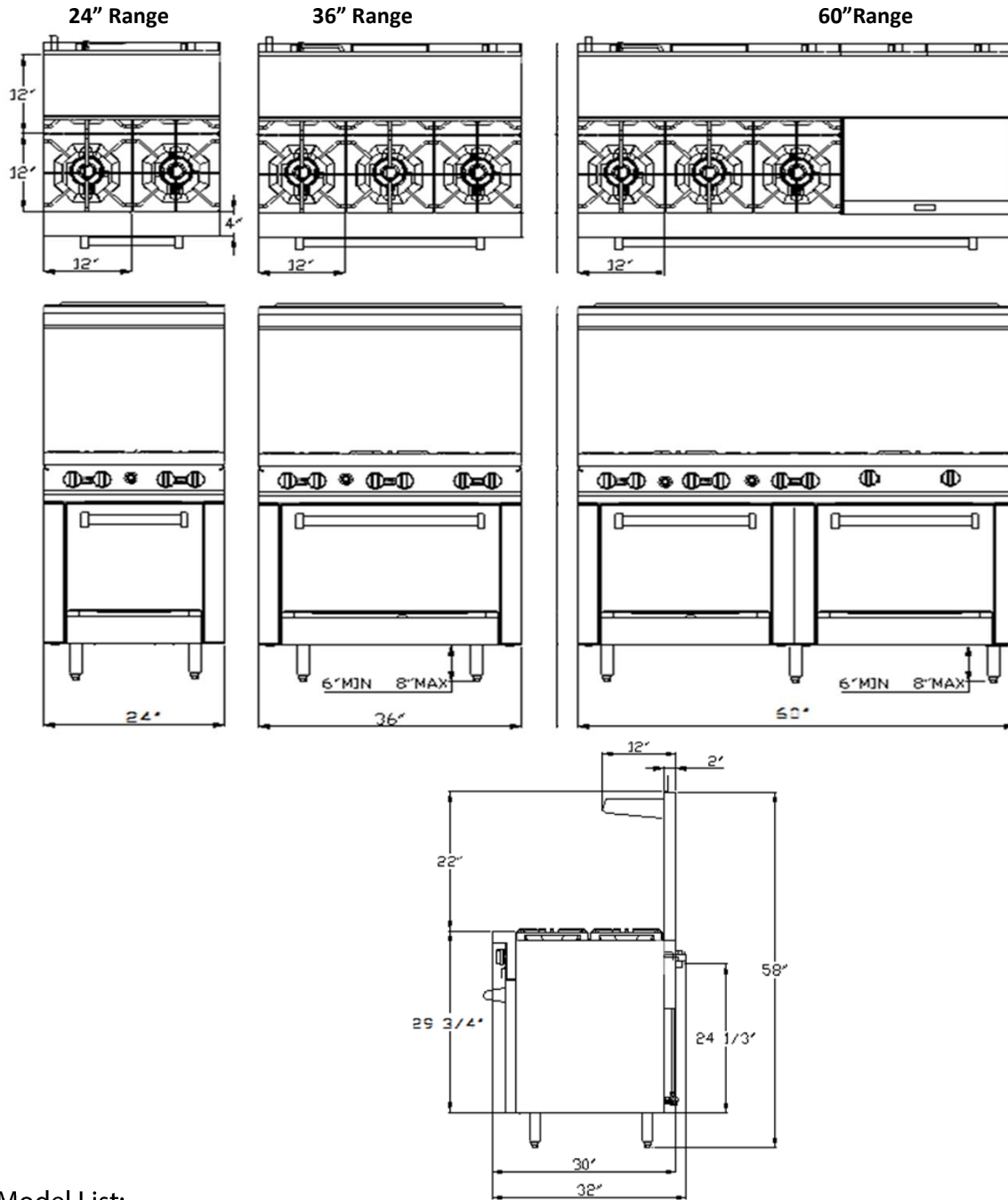

Model List:

| Model | View | Top Burners | Top Griddle | Top Charbroiler | Bottom Oven | Total kBTU (NG) | Total kBTU (LP) | Gas Pressure | Width (cm) | Depth (cm) | Height (cm) | Gross Weight (kgs) |
|----------------|------|-------------|-------------|-----------------|-------------|-----------------|-----------------|--------------|------------|------------|-------------|--------------------|
| PT-R24 | | 4 | | | One 24" | 153 | 136 | 5"NG / 10"LP | 71 | 94 | 111 | 160.5 |
| PT-R36 | | 6 | | | One 36" | 213 | 190 | 5"NG / 10"LP | 101 | 94 | 111 | 212 |
| PT-R36-24MG-2B | | 2 | 24" | | One 36" | 153 | 136 | 5"NG / 10"LP | 101 | 94 | 118 | 239 |
| PT-R60 | | 10 | | | Double 36" | 366 | 326 | 5"NG / 10"LP | 165 | 94 | 111 | 339.5 |
| PT-R60-24MG | | 6 | 24" | | Double 36" | 306 | 272 | 5"NG / 10"LP | 165 | 94 | 118 | 371 |
| PT-R60-24CB | | 6 | | 24" | Double 36" | 316 | 288 | 5"NG / 10"LP | 165 | 94 | 118 | 351 |
| PT-R60-24RG-6B | | 6 | 24" | | Double 36" | 306 | 272 | 5"NG / 10"LP | 165 | 94 | 118 | 371 |

| Description | BTU per burner | Orifice size |
|------------------|----------------|--------------|
| Top burner | NG 30,000 | 2.40mm |
| | LP 27,000 | 1.55mm |
| Top griddle | NG 30,000 | 2.40mm |
| | LP 27,000 | 1.55mm |
| Top char broiler | NG 35,000 | #36 |
| | LP 35,000 | #49 |
| Oven | NG 33,000 | 2.60mm |
| | LP 28,000 | 1.50mm |

Installation, Operation and Care:

PLEASE KEEP THIS MANUAL FOR FUTURE REFERENCE

GENERAL

Ranges are produced with quality workmanship and material. Proper installation, usage and maintenance of your range will result in many years of satisfactory performance.

Suggests that you thoroughly read this entire manual and carefully follow all of the instructions provided.

▲WARNING

THIS APPLIANCE IS EQUIPPED FOR NATURAL GAS, for conversion to LP gas please see gas conversion instruction manual attached. Orifices necessary for LP (propane) (natural) conversion are provided. Please refer to page 3 the orifice size list when you do gas conversion

INSTALLATION

UNCRATING

This range was inspected before leaving the factory. The transportation company assumes full responsibility for safe delivery upon acceptance of the shipment. Immediately after unpacking, check for possible shipping damage. If the range is found to be damaged, save the packaging material and contact the carrier within 15 days of delivery.

Uncrate unit carefully and place in a work-accessible area as near to its final installed position as possible. Remove all shipping wire and wood blocking.

Before installing, check the type of gas supply (natural or propane) to make sure they agree with the specifications on the rating plate located on the inside of the lower kick panel. If the supply and equipment requirements do not agree, do not proceed with the installation. Contact your dealer or company immediately.

LOCATION

The appliance must be installed under a ventilation hood.

The equipment area must be kept free and clear of combustible substances.

The range, when installed, must have a minimum clearance from combustible construction of 12" (304 mm) at the sides and 10" (253 mm) at the rear. Clearance from non-combustible construction is 0" at

the sides and 6" (152 mm) at the rear.

The installation location must allow adequate clearances for servicing and proper operation. A minimum front clearance of 40" (1016 mm) is required.

The range must be installed so that the flow of combustion and ventilation air will not be obstructed. Adequate clearance for air openings into the combustion chamber must be provided. Make sure there is an adequate supply of air in the room to allow for combustion of the gas at the burners.

INSTALLATION CODES AND STANDARDS

Ranges must be installed in accordance with:

In the United States of America:

1. State and local codes.
2. National Fuel Gas Code, ANSI/Z223.1 (latest edition). Copies may be obtained from The American Gas Association, Inc., 1515 Wilson Blvd., Arlington, VA22209.

In Canada:

1. Local codes.
2. CSA B149.1 Natural Gas and Propane Installation Code.
3. CSA C22.1 Canadian Electric Code.
4. CSA C22.2 Canadian Electric Code.

The above are available from the Canadian Standard Association, 5060 Spectrum Way, Suite 100, Mississauga, Ontario, Canada L4W 5N6.

ASSEMBLY: Ranges Mounted on Casters

Ranges mounted on casters must use a flexible connector (not supplied by CHEF N'SAVE) that complies with the Standard for Connectors for Movable Gas Appliances, ANSI-Z21.69 • CSA 6.16 and a quick-disconnect device that complies with the Standard for Quick-Disconnect Devices for Use With Gas Fuel, ANSI-Z21.41 • CSA 6.9. In addition, adequate means must be provided to limit movement of the appliance without depending on the connector and the quick-disconnect device or its associated piping to limit appliance movement. Attach the restraining device at the rear of the range as shown in Fig. 1.

Remove two screws from the rear of the range and install the tie-down strap shipped with the casters using these screws (Fig. 1). Attach the gas line strain relief to the tie-down strap at the rear of the range (Fig. 1).

If disconnection of the restraint is necessary, turn off the gas supply before disconnection. Reconnect this restraint prior to turning the gas supply on and returning the range to its installation position.

Separate instructions for installing casters to the range are included with the casters.

Note: If the range is installed on casters and is moved for any reason, it is recommended that the range be leveled front to back and side to side.



Backsplash

The standard Restaurant Range is equipped with a 23" (584 mm) high backsplash and shelf.

1. Remove the backsplash components from the crating materials.
2. Assemble the required components as shown in Fig's. 2 and 3 and 4.



3. Tighten the four screws to secure the shelf.



4. Lift the assembly up, sliding the channels into the space provided at the rear of the range.(Fig's. 5).

Fig. 5



4. Install four #10 sheet metal screws (2 to each channel leg) (Fig. 6).



Fig.6

LEVELING

Check the leveling of the range. Place a level inside the oven cavity across the oven rack(s). Level front-to-back and side-to-side.

To adjust the leveling, tilt the range to one side and, using channel locks, unscrew the adjustable leg insert as required. Repeat this procedure as necessary for each leg.

Optional casters for this range are of the non-adjustable type. Therefore, the floor must be level. If floor surface is not level, the range will experience cooking problems.

GAS CONNECTIONS

CAUTION: All gas supply connections and any pipe joint compound used must be resistant to the action of propane gases.

Fig.7



Each range is factory-equipped for the type gas specified on the rating plate. The installation gas connection is a $\frac{3}{4}$ " (19 mm) 14 FPT ANSI schedule #40 standard pipe. Connect gas supply. Make sure the pipes are clean and free of obstructions. Codes require that a gas shutoff valve be installed in the gas line ahead of the range. Standard ranges are equipped with fixed burner orifices which coincide with installation elevation. Install the gas pressure regulator. Before installing, ensure that regulator supplied agrees with rating plate gas supply. The gas pressure regulator is **NOT** factory installed. The regulator for this gas type is sealed within a plastic bag attached to the oven rack inside the oven cavity. This regulator must be field installed by a qualified installer.

Natural gas regulators are preset for 5" W.C. (Water Column) (.99 kPa); propane gas regulators for 10.0" W.C. (2.5 kPa)

1. Locate $\frac{3}{4}$ " (19 mm) gas connection pipe extending from rear of range.
2. Cover pipe threads with leak sealant.
3. Screw regulator hand-tight onto pipe with regulator arrow pointing towards range body back (Fig. 7).
4. Using pipe wrench, tighten regulator securely in an upright position (Fig. 7).

The arrow on the regulator shows the direction of the gas flow. The pressure regulator must be mounted horizontally to ensure proper preset outlet pressure. If the regulator is installed in any other position, the outlet pressure must be reset for proper operation. A leak limiter is supplied with every regulator to allow excess gas pressure to escape. Do not obstruct leak limiter on gas pressure regulator, as obstruction may cause regulator to malfunction.

WARNING: PRIOR TO LIGHTING, CHECK ALL JOINTS IN THE GAS SUPPLY LINE FOR LEAKS. USE SOAP AND WATER SOLUTION. DO NOT USE AN OPEN FLAME.

After piping has been checked for leaks, all piping receiving gas should be fully purged to remove air.

Before operation, verify thermocouple is securely seated in the safety valve. The thermocouple should be tightened a $\frac{1}{4}$ turn past finger tight. **DO NOT OVERTIGHTEN.** Over-tightening may damage the thermocouple or safety magnet.

TESTING THE GAS SUPPLY SYSTEM

When gas supply pressure exceeds $\frac{1}{2}$ psig (3.45 kPa), the range and its individual shutoff valve must be disconnected from the gas supply piping system.

When gas supply pressure is 1/2 psig(3.45kPa) or less, the range should be isolated from the gas supply system by closing its individual manual shutoff valve until the range is ready for start-up.

FLUE CONNECTIONS DO NOT obstruct the flow of flue gases from the flue located on the rear of the range. It is recommended that the flue gases be ventilated to the outside of the building through a ventilation system installed by qualified personnel.

From the termination of the flue to the filters of the hood venting system, a minimum clearance of 18" (457 mm) must be maintained.

Information on the construction and installation of ventilating hoods may be obtained from the standard for the "Removal of Vapors from Commercial Cooking Equipment" , NFPA No. 96 (latest edition), available from The National Fire Protection Association, Batterymarch Park, Quincy, MA 02269.

OPERATION

WARNING: THE RANGE AND ITS PARTS ARE HOT. BE VERY CAREFUL WHEN OPERATING, CLEANING OR SERVICING THE RANGE.

CONTROLS

THERMOSTAT DIAL

Allows operator to regulate oven temperature from low to 500° F (260° C)

(OPTIONAL) GRIDDLE BURNER KNOB

Regulates gas flow to the griddle. To increase heat, turn knob counterclockwise, to decrease heat, turn knob clockwise.

BEFORE FIRST USE

Griddle Seasoning (*optional models*)

CAUTION: This griddle plate is steel, but the surface is relatively soft and can be scored or dented by the careless use of a spatula or scraper. Be careful not to dent, scratch, or gouge the plate surface. Do not try to knock off loose food that may be on the spatula by tapping the corner edge of the spatula on the griddle surface.

A new griddle surface must be seasoned to do a good cooking job. The metal surface of the griddle is porous. Food tends to get trapped in these pores and stick; therefore, it is important to "season" or "fill up" these pores with cooking oil before cooking. Seasoning gives the surface a slick, hard finish from which the food will release easily.

To season, heat griddle top section at a low burner setting. Pour one ounce of cooking oil per

square foot of surface over the griddle top section. With an insulated cloth, spread the oil over the entire griddle surface to create a thin film. Wipe off any excess oil with an insulated cloth. Repeat this procedure 2 to 3 times until the griddle has a slick surface.

LIGHTING AND SHUTTING DOWN PILOTS

All adjustment procedures associated with pilot lighting must be performed **by an authorized vender installation or service person.**

OPEN TOP BURNERS

1. Turn main gas supply ON.
2. Wait 30 seconds and, using a taper, light the open top pilot
3. If pilot fails to light, turn main gas supply OFF. Wait 5 minutes and repeat the above procedures.
4. Turn one open top burner valve ON to remove air from the gas line. Turn burner OFF when gas begins to flow.

Nightly Shutdown

1. Turn burner valve OFF; pilot will remain lit.

Complete Shutdown

1. Turn burner valve OFF; pilot will remain lit.
2. Turn main gas supply OFF.

GRIDDLE (*optional models*)

1. Turn main gas supply ON. Wait 30 seconds and, using a taper, light broiler/griddle pilot.
Fig.8
2. If pilot fails to light, turn main gas supply OFF. Wait 5 minutes and repeat Steps 1 and 2.
3. Turn burner valve ON to purge air from the lines. Turn burner valve OFF when gas begins to flow.

Nightly Shutdown

1. Turn burner valve OFF; pilot will remain lit.

Complete Shutdown

1. Turn burner valve OFF; pilot will remain lit.
2. Turn main gas supply OFF.



Fig.8

STANDARD OVEN LIGHTING AND SHUTDOWN INSTRUCTIONS NOTE:

Light open top/griddle pilots before lighting oven pilot.

STANDARD OVEN

1. Turn thermostat to the "OFF" POSITION.
2. Rotate bottom tick-plate, expose the ignition hole
3. Depress down the knob and rotate about 15° anti-clockwise, Ignite the pilot flame with fire gun via the ignition hole. Fig.9 & Fig.10

4. After the pilot flame is ignited, press the knob for more than 20 seconds to heat up the thermocouple.

If the ignition is out when you loosen the knob, repeat this operation.

5. Keep rotating the temperature control knob counterclockwise to ignite the main burner of the oven.

6. Select appropriate temperature according to food requirement. The oven temperature can be controlled between 250F and 500F.

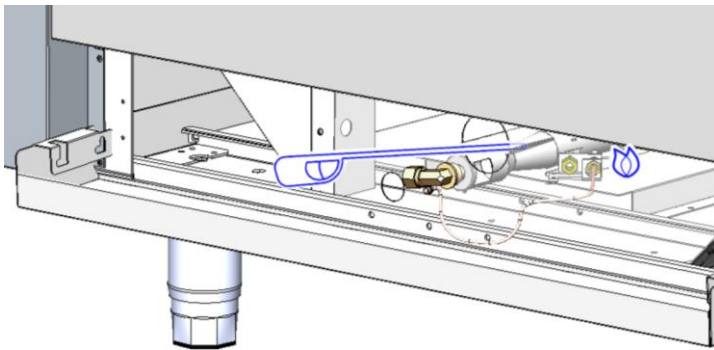
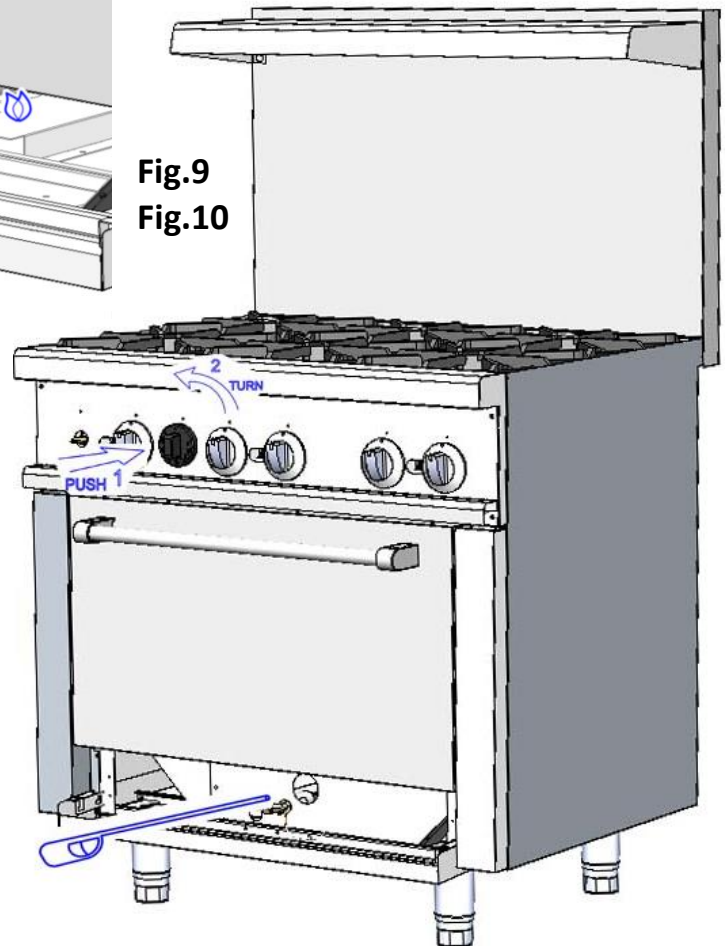

Fig.9
Fig.10



Nightly Shutdown

1. Turn oven thermostat OFF.

Complete Shutdown

1. Turn oven thermostat OFF.
2. Turn main gas supply OFF.

RACK ARRANGEMENT -STANDARD OVEN

The standard oven has three rack positions and is supplied with ~~one~~ two oven racks. Additional racks may be obtained through a vender parts depot.

INSERTING AND REMOVING RACK

The oven rack has a stop to keep the rack from being pulled all the way out when unloading product. To install rack, place rack alongside of top of side liner runners and slide rack completely to the rear of the oven compartment until rack drops into place

To remove rack, reverse the procedure above by raising rear of oven rack stop above runner and pulling rack forward.

PREHEATING

Standard Oven Turn thermostat control to the desired cooking temperature and preheat oven for 25 minutes. To save on gas consumption, do not operate oven at maximum heat when it is not necessary. Turn thermostat down to 250°F (121°C) or OFF when oven is not in use or during idle cooking periods.

Griddle (*optional models*)

Turn manual gas valve knobs to full ON. After preheating for 5 minutes, turn valves down until desired flame or heating level is achieved. Position the removable broiler grid into one of the two slide positions, depending on which will achieve the proper product results.

CLEANING

Do not use scouring powder or abrasives anywhere on this range
Clean only using a soft cloth and mild detergent solution.

MAINTENANCE

WARNING: THE RANGE AND ITS PARTS ARE HOT. BE VERY CAREFUL WHEN OPERATING, CLEANING OR SERVICING THE RANGE.

VENT

When cool, the vent should be checked every six months for obstructions.

SERVICE AND PARTS INFORMATION

To obtain repairs, service and parts information concerning this model, contact supplier. When calling for service, the following information must be available: model number, serial number, manufacture date (MD) and voltage (optional models).

GAS RESTAURANT RANGES

We all recognize, however, that replacement parts and occasional professional service may be necessary to extend the useful life of this unit. When service is needed, contact a RANGE Authorized Service Agency, or your dealer. To avoid confusion, always refer to the model number, serial number, and type of your unit.



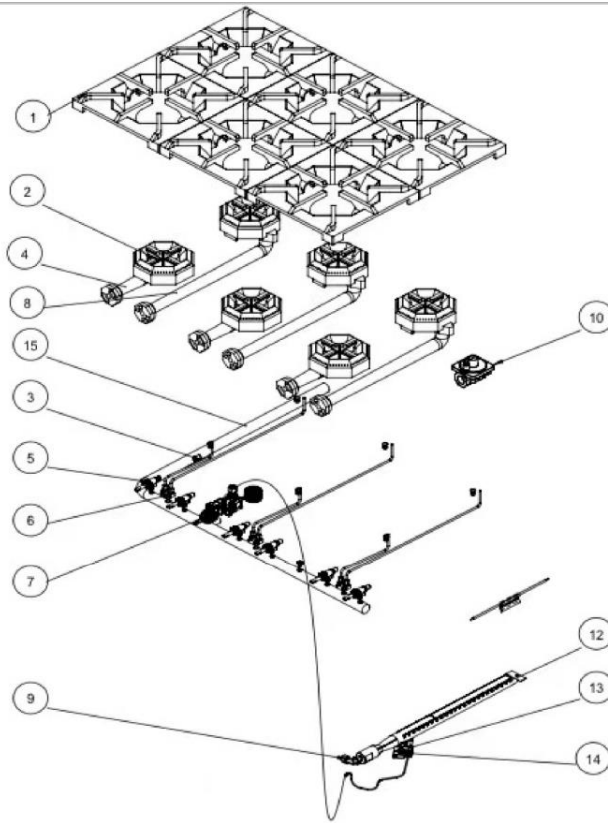

36" Range parts Gas system

| Key | Part Number | Q'ty | Description |
|-----|-------------|------|---------------------------|
| 1 | 302250151 | 6 | Grate for hotplate |
| 2 | 20301C001 | 6 | Buner for hotplate |
| 3 | 302150041 | 6 | Natural orifice, hotplate |
| | 302150042 | 6 | LP orifice, hotplate |
| 4 | 20301C007 | 3 | Front top burner |
| 5 | 302220059 | 6 | Manual gas valve |
| 6 | 302220027 | 3 | Pilot Valve, for Hotplate |
| 7 | 20103C024 | 1 | Oven thermostat |
| 8 | 20301C019 | 3 | Back top burner |
| 9 | 21102C004 | 1 | Oven orifice |
| 10 | 309020069 | 1 | Regulator |
| 11 | 03900080 | 1 | Oven thermocouple |
| 12 | 03510036 | 1 | Oven pilot bracket |
| 13 | 211010358 | 1 | Oven burner |
| 14 | 20207C015 | 1 | Oven pilot tube |
| 15 | 211010358 | 1 | Gas pipe |

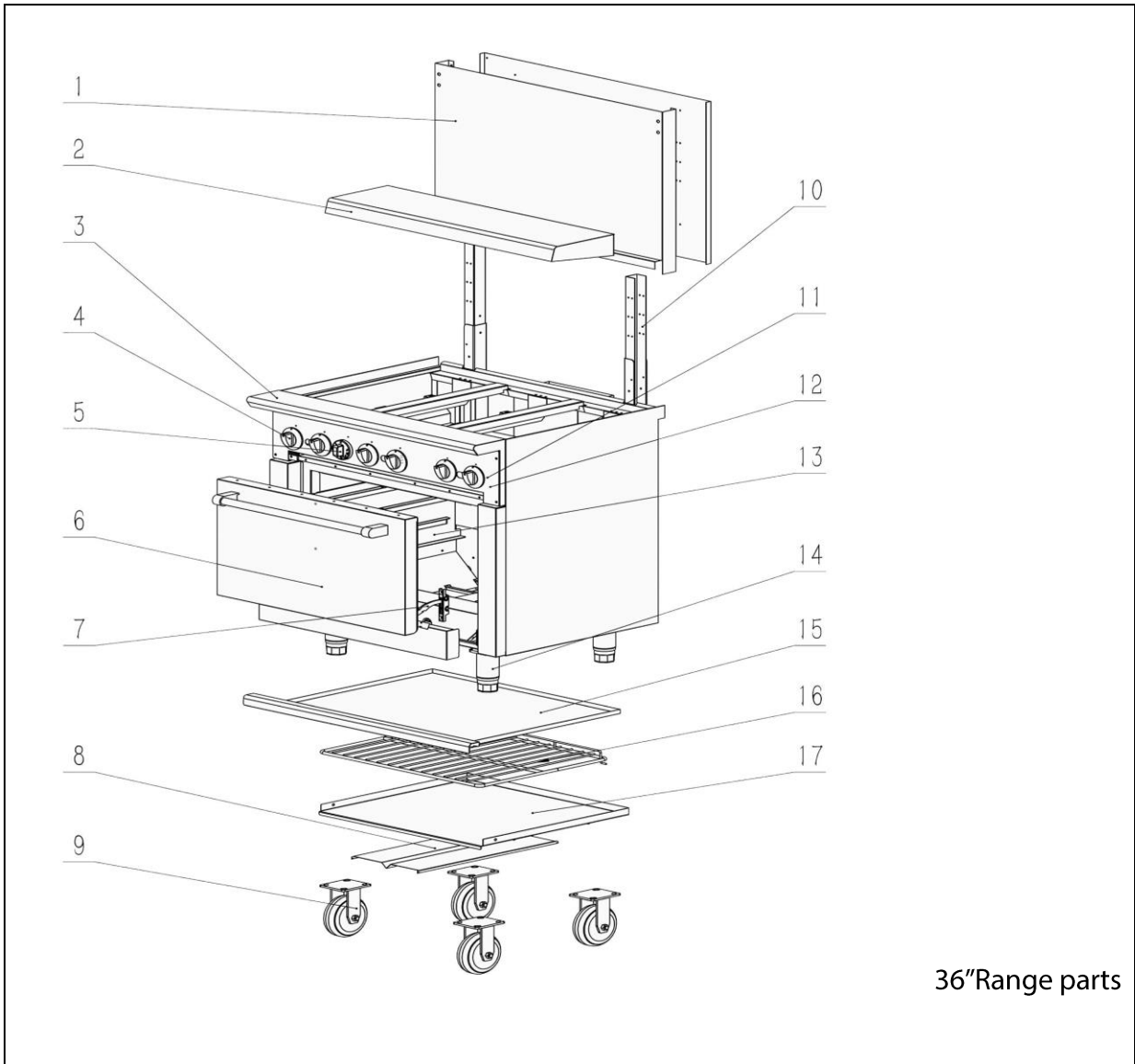

36"Range parts

| Key | Part Number | Q'ty | Description |
|-----|----------------|------|--------------------------------|
| 1 | FS-100105 | 1 | 6B back splash |
| 2 | | 1 | Shelf board |
| 3 | | 1 | Front table |
| 4 | FS-301110405 | 6 | Knob |
| 5 | FS-03900267 | 1 | Oven thermostat knob |
| 6 | FS-100103 | 1 | Oven door |
| 7 | | 2 | Oven door hinge |
| 8 | FS-4000391 | 1 | Oven radiant plate |
| 9 | FS-2660002 | 4 | Caster set for 36"range |
| 10 | | 2 | Chimney pillar support beam |
| 11 | FS-20228062002 | 1 | Front panel for 6B range |
| 12 | FS-303123917 | 1 | Mylar for 6B range |
| 13 | FS-400040 | 1 | Oven shelf bracket left |
| | FS-400041 | 1 | Oven shelf bracket right |
| 14 | FS-302090048 | 4 | 6"adjustable leg |
| 15 | FS-20228055008 | 1 | Drop pan for 6B range |
| 16 | FS-400050 | 2 | Oven shelf for 6&10 burner use |
| 17 | FS-20228055011 | 1 | Oven drip pan 36" |

TROUBLESHOOTING GUIDE

STANDARD OVEN RESTAURANT RANGE

OVEN

| PROBLEM | CAUSES |
|---|--|
| 1. Too much bottom heat 1a. Too low temperature 1b. Side burning 1c. Too much top heat | a) Insufficient ventilation b) Improper fluing c) Improper thermostat bypass setting d) Thermostat out of calibration e) Fluctuating gas pressure |
| 2. Uneven bake side to side | a) Not level side to side b) Oven burner, bottom or baffles improperly installed c) Warped pans |
| 3. Uneven bake front to rear | a) Overactive flue b) Not level front to back; check casters and legs c) Door not closing properly |
| 4. Dried out products | a) Too low temperature (overcooking) b) Too long baking time c) Thermostat calibration |
| 5. Pilot outage | a) Pilot flame too low b) Restriction in pilot orifice c) Problem with shutoff valve d) Possible fluing problems e) Low pressure f) Improper gas line sizing g) Burner box cover not properly installed h) Oven cavity requires resealing |

TOP BURNER OPERATION

| | |
|--|---|
| 1. Improper burner combustion Excessive valve handle temperatures Sticking top burner valves | a) Improper ventilation b) Poor door fit c) Oven door left open d) improper use of excessively large pans or pots |
| 2. Poor ignition | a) Insufficient input b) Poor air-gas adjustment c) Restriction in pilot orifice d) Restriction in main burner ignition port |

Conversion Kit Instructions for the Gas restaurant ranges

WARNING

This conversion kit shall be installed by a qualified service agency in accordance with the manufacturer's instructions and all applicable codes and requirements of the authority having jurisdiction. If the information in these instructions is not followed exactly, a fire, an explosion or production of carbon monoxide may result causing property damage, personal injury or loss of life. The qualified service agency is responsible for the proper installation of this kit. The Installation is not proper and complete until the operation of the converted appliance is checked as specified in the manufacturer's instructions supplied with the kit."

Range Conversion Kit Instructions



Do not attempt gas conversion by yourself. Gas conversion of your unit is to be made by a certified/licensed technician.

CONVERSION

Instructions are for conversion from Natural Gas to Propane (L.P.) on 24" & 36" models. The conversion should be done before connecting the unit to the gas supply. Units are shipped from the factory equipped for use on natural gas. Parts necessary for L.P. (liquid propane) are provided with the unit. Please refer to page 5 the orifice size list when you do gas conversion..

Turn off the main gas supply before doing any maintenance.

1. Remove the grate
2. Remove the top burner.



- 3, Screw out top burner air shutter screw

- 4, Adjust air shutter from half open to full open, then screw in, ensure fix well.

- 5, Remove orifice.



6. Replace the orifice, burner and grate



Note: Unit Number on side of orifice fittings

7. Remove the drop pan, unscrew nut of oven burner

8. Incline the burner, expose orifice of oven



9. Replace the orifice fittings into the valve.

10. Screw out oven burner air shutter screw



11. Adjust oven burner air shutter from half open to full open. then screw in, ensure fix well

12. Replace orifice and oven burner

13. Regulator convert

Before installing the included convertible regulator, unscrew the octagon cap. You can read (NAT) on the plastic insert attached to the head of the cap; flip it over and snap back in place.



Convertible regulator with octagon cap. Unscrew from regulator.

L.P. Position of insert. Regulator is now converted to L.P.

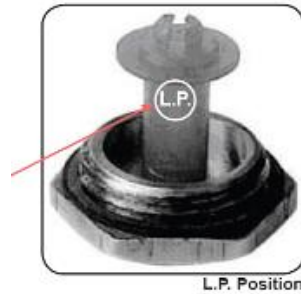

Pictured is the plastic insert. Pull off insert from octagon cap and reverse the plastic insert position so that the L.P. position is attached to the octagon cap head.

14. Continue with installation.
15. Attach gas conversion label on appliance, the position below.
Gas conversion label

This appliance was converted on (day-month-year) to gas with Kit No. by (name and address of organization making this conversion), which accepts the responsibility that this conversion has been properly

The position for gas conversion

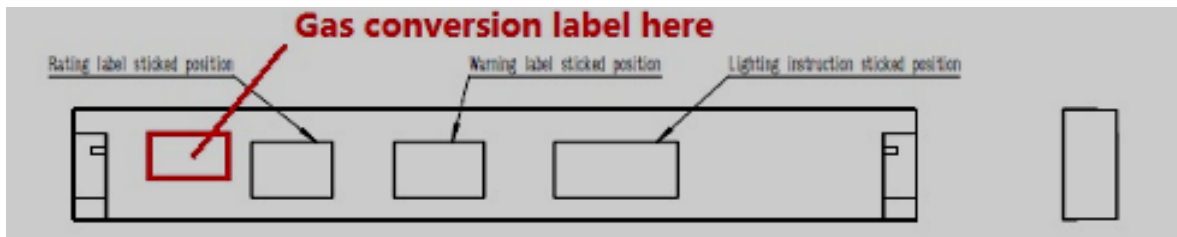

16. Completed gas conversion.

PATRIOTTM

WARRANTY

Patriot warrants its equipment against defects in materials and workmanship, subject to the following conditions:

Patriot gas equipment is warranted for one (1) years, effective from the date of purchase by the original owner. A copy of the original receipt or other proof of purchase is required to obtain warranty coverage. This warranty applies to the original owner only, and is not assignable.

The stainless steel fry tank has a five (5) year limited tank warranty. If during the first year, the tank is found to have a leak and is verified by an authorized service company, the entire fryer will be replaced. During years two through five, a new tank will be given.

Should any product fail to function in its intended manner under normal use within the limits defined in this warranty, at Patriot's discretion, such product will be repaired, replaced with a refurbished unit, or replaced with a new unit by Patriot, after defective unit has been inspected and defect has been confirmed. Patriot does not assume any liability for extended delays in replacing any item beyond its control. This warranty does not apply to rubber and non-metallic synthetic parts that may need to be replaced due to normal usage, wear or lack of preventative maintenance.

This warranty covers products shipped into the 48 contiguous United States, Hawaii, and metropolitan areas of Alaska and Canada. Warranty coverage on products used outside the 48 contiguous United States, Hawaii and metropolitan areas of Alaska and Canada may vary.

The following conditions are not covered by warranty:

- Equipment failure relating to improper installation, improper utility connection or supply and problems due to improper ventilation.
- Equipment that has not properly been maintained, damage from improper cleaning, and water damage to controls.
- Equipment that has not been used in an appropriate manner, or has been subject to misuse, neglect, abuse, accident, alteration, negligence, damage during transit, delivery or installation, fire, flood, riot, or act of God.
- Equipment that has the model number or serial number removed or altered.
- Equipment on which the security seal has been broken.

If the equipment has been changed, altered, modified, or repaired without express written permission from Patriot, then the manufacturer shall not be liable for any damages to any person or to any property, which may result from the use of this equipment thereafter.

This equipment is intended for commercial use only and this warranty is void if equipment is used in other than a commercial application.

For warranty issues and technical support call Patriot Cooking at 888-585-9440. Please have your model number, serial number and proof of purchase ready.

"THE FOREGOING WARRANTY IS IN LIEU OF ANY AND ALL WARRANTIES EXPRESSED OR IMPLIED INCLUDING ANY IMPLIED WARRANTY OF MERCHANTABILITY OR FITNESS FOR PARTICULAR PURPOSES AND CONSTITUTES THE ENTIRE LIABILITY OF PATRIOT. IN NO EVENT DOES THE LIMITED WARRANTY EXTEND BEYOND THE TERMS STATED HEREIN."

Please register your product online at Patriotcooking.com

