

Operation Manual

Mustard Dispenser
Model No. 398-CN

Product Identification

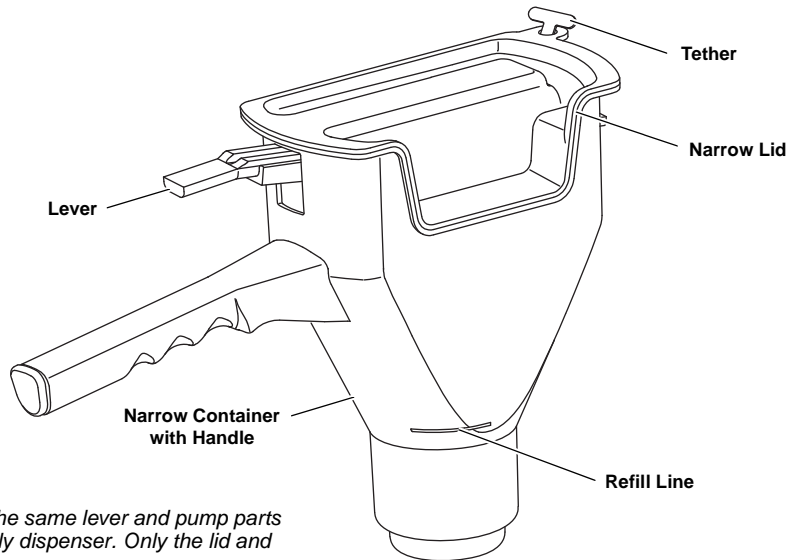

Note: This dispenser uses the same lever and pump parts as the standard mustard-only dispenser. Only the lid and container are different.

LIMITED WARRANTY

This product is warranted to be free from defects in material and/or workmanship for a period of two (2) years from date of original installation, not to exceed 30 months from date of original shipment from our factory. If this product proves to be faulty in material and/or workmanship, it will be replaced or repaired (at the option of Prince Castle, Inc.) without cost to the customer for parts.

TABLE OF CONTENTS

| | |
|--|----|
| Product Identification | 1 |
| Safety Information | 2 |
| Important | 2 |
| Setup | 2 |
| Calibration | 3 |
| Operation | 3 |
| Cleaning | 4 |
| Troubleshooting | 4 |
| Ordering/Service Information | 4 |
| Exploded View and Parts List | 5 |
| Parts Kits | 6 |
| Tips on Improving Mustard Dispensing (English, Spanish, French) | 7 |
| Instruction Sheet | 10 |

PRINCE CASTLE INC. 
WORLDWIDE

 A Marmon Group / Berkshire Hathaway Company
355 East Kehoe Blvd. • Carol Stream, IL 60188 USA
Telephone: 630-462-8800 • Toll Free: 1-800-PCASTLE
Fax: 630-462-1460 • www.princecastle.com

Safety Information

CAUTION

Indicates information important to the operation of the unit. Failure to observe may result in damage to the equipment.

Hazard Communication Standard (HCS) – Procedure(s) in this equipment manual include the use of chemical products. These chemical products will be highlighted with bold face letters followed by the abbreviation (HCS) in the text of the manual. See the Hazard Communication Standard (HCS) Manual for the appropriate Material Safety Data Sheet(s) (MSDS).

Important

Prince Castle reserves the right to change specifications and product design without notice. Such revisions do not entitle the buyer to corresponding changes, improvements, additions or replacements for previously purchased equipment.

Setup

1 Place dispenser container in prep table pan (without internal parts).
Note: Before filling dispenser, shake mustard container vigorously. Be sure lid on mustard gallon is tightly sealed.

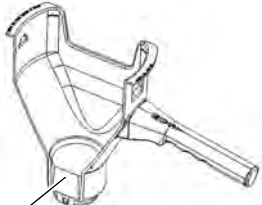
2 Fill the lower cavity of the empty container with mustard (approximately 2 inches).

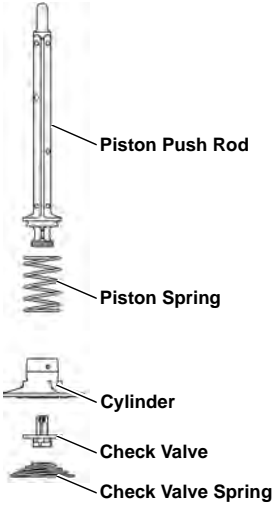
 Fill with approximately 2 inches of mustard

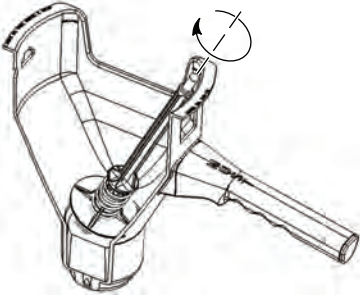
3 Assemble all internal parts of the spring assembly.

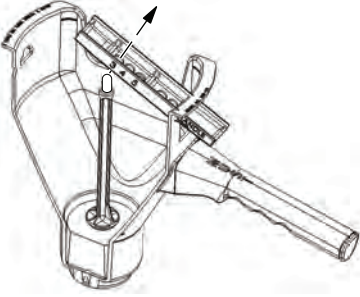
 Piston Push Rod
 Piston Spring
 Cylinder
 Check Valve
 Check Valve Spring

4 Place assembled parts into dispenser at an angle. Rotate assembly one full turn while inserting into mustard-filled bottom.
Note: Make sure cylinder is filled with mustard in lower cavity.

5 Place adjusting cam on top of piston push rod and insert push rod into hole #3 of adjusting cam.
Note: Make sure that arrow on side of adjusting cam points to handle of dispenser and numbers are facing up.

Setup (continued)

- 6** Attach lever so rounded corners face down towards the adjusting cam.

- A. Slide lever through the hole in the container located above the handle of the dispenser.
- B. Continue to slide the lever forward over adjusting cam while pressing down on the adjusting cam and the piston push rod.
- C. Continue to slide the lever forward until the push rod falls into the hole located in the lever.
- D. Continue pressing adjusting cam and push rod while sliding the lever forward until the front end enters the "T"-shaped hole on the other side of the container.

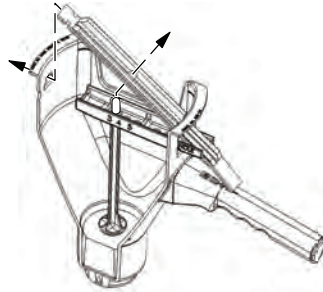

- 7** Dispenser is now fully assembled. Pour mustard into the container. Place the lid on top of the container before using the dispenser.

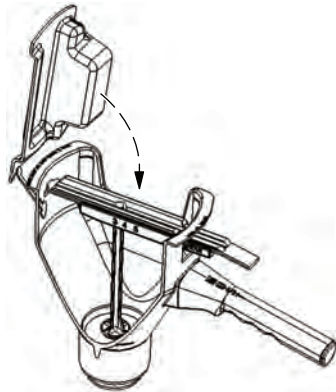

- 8** The mustard dispenser must be primed before using. Press down on lever several times (approximately 20) to completely prime.

- 9** Wipe the bottom of the dispenser with a clean, moist hand towel after priming.

Note: If air remains in the piston spring and cylinder area, the dispenser will not dispense the correct amount of mustard, and mustard will drip after each shot. To release trapped air, remove lever and cam, and gently pull out piston push rod and all assembled parts. Repeat steps 4 thru 8 to reassemble. If necessary, empty some of the mustard already in container before reassembling.

Calibration

- 1** Set Brix cup under dispenser and dispense 47 shots of mustard into cup.

Note: Allow the lever to return fully after each shot.

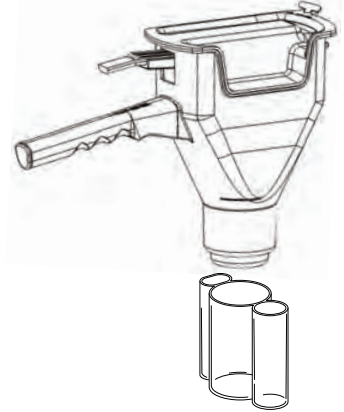

- 2** 47 shots will dispense 1 fl. oz. (30 ml) of mustard into the Brix cup.

- A. If the amount of mustard dispensed into the cup is above 1 fl. oz. (30 ml), move adjusting cam from hole #3 to hole #2 to DECREASE volume.
- B. If below 1 fl. oz. (30 ml), move to hole #4 to INCREASE the amount of mustard dispensed.

- 3** Repeat this adjustment until dispenser is calibrated.

Note: The lower numbered holes dispense less mustard. The higher numbered holes dispense more mustard. For all hole number settings, the arrow mark on the side of the adjusting cam must always point towards the handle of the dispenser.

Operation

This dispenser is used for portion control of mustard being dispensed on toasted buns.

- After buns are separated and placed on the prep table, hold dispenser approximately 1" (25 mm) above toasted bun.
- Press lever all the way down to dispense mustard on the caramelized surface of the toasted bun. This is repeated on all buns which require mustard.

Note: The mustard dispenser has a YELLOW cap on the end of the handle for easy identification.

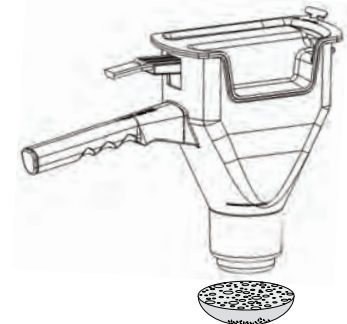

Cleaning

1 Empty mustard from dispenser and discard.

2 Fill dispenser with warm water. Repeatedly press actuating lever to pump water and flush out dispenser.

3 Remove internal parts from container by pushing down on the lever and the piston push rod. Slide the lever out of the "T" shaped hole in the container. Remove the adjusting cam.

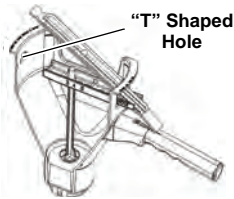

4 Lift the push rod and the spring assembly straight up and out of the container.

5 Separate all internal parts to clean thoroughly. Wash the container and all loose internal parts in a solution of warm water and **All Purpose Concentrate (APC) (HCS)**.

6 Rinse all loose parts and the container with running water.

7 Sanitize dispenser. Use 1 packet of **Sanitizer (HCS)** to 2-1/2 gallons (8.5 l) of warm water.

8 Let air dry.
Note: Do not reassemble dispenser until it is ready to be used the next day.

Troubleshooting

| PROBLEM | PROBABLE CAUSE | SOLUTION |
|--|--|--|
| Will not dispense | Plastic parts broken. | Replace broken parts. |
| | Not assembled properly. | Assemble properly. |
| | Not primed. | See Setup procedure. |
| | Parts missing. | Check for proper assembly and placement. |
| Does not dispense full portion. | Out of calibration. | Re-calibrate. (See Calibration instructions.) |
| Mustard pattern is irregular. | Diffuser holes plugged in bottom of container. | Disassemble and clean diffuser holes by flushing water through holes. |
| Does not dispense correct amount and mustard drips from dispenser after each shot. | Air pocket in piston spring and cylinder area. | Remove lever and cam, gently pull piston push rod and assembly parts from mustard to release trapped air. Reassemble. (See Setup.) |
| Mustard collects on bottom of dispenser. | Bottom of dispenser has made contact with bun. | Wipe off bottom of dispenser with damp cloth. |

Ordering/Service Information

1 **WHERE AND HOW TO ORDER REPLACEMENT PARTS**
 To order replacement parts, look on the back of your Prince Castle Price List for the name and phone number of your local Prince Castle Service Center. You may also call Prince Castle at 1-800-323-2930 (or fax us at 630-462-1460) for the name of your local service center.

2 **PARTS RETURNS**
 To return parts to your service center for credit, you must obtain authorization from your center.
Note: All warranty situations should be handled by your center.

3 **PRICES**
 A. All prices are F.O.B. Prince Castle Service Center or F.O.B. factory, Carol Stream, Illinois.
 B. All prices are subject to change without notice. These prices are exclusive of all sales taxes or any special taxes which may be levied by federal, state, or city governments.

OUTSIDE THE U.S.

Contact your kitchen equipment supplier or designated repair facility for parts and service.

NON-SCHEDULED MAINTENANCE

Not applicable.

Exploded View and Parts List

| ITEM | PART NO. | DESCRIPTION | QTY | FUNCTION |
|------|----------|--------------------------------------|-----|--|
| 1 | 398-112 | Narrow Container with Handle | 1 | Holds all internal parts in proper position and provides a reservoir for mustard. |
| 2 | 404-7 | Check Valve Spring | 1 | Returns check valve to the closed position. |
| 3 | 398-034 | Check Valve | 1 | Works in conjunction with piston push rod. |
| 4 | 398-091 | Cylinder | 1 | Holds mustard. |
| 4a | N/A | Cylinder, Valve, and Spring Assembly | 1 | Consists of Items 2, 3, 4 and 5. |
| 5 | 398-20 | Piston Spring | 1 | Returns the piston to the UP position. |
| 6 | 398-032 | Piston Push Rod | 1 | Pumps mustard through the check valve and out of the 5 holes located on the bottom of the container. |
| 7 | 398-031 | Adjusting Cam | 1 | Calibrates the dispenser for proper volume of mustard to be dispensed. |
| 8 | 398-033 | Lever | 1 | Pushes plunger rod down and forces piston to push mustard through diffuser holes located on bottom of container. |
| 8a | N/A | Lever and Cam Assembly | 1 | Consists of Items 7 and 8. |
| 9 | 404-13S | Tether (pkg. of 6) | 1 | Attaches the lid to the container. |
| 10 | 406-152S | Narrow Lid with Tether (pkg. of 3) | 1 | Keeps foreign particles out of container and keeps mustard from drying out. |

Note: Parts are not sold individually. See Part Kits on page 6.

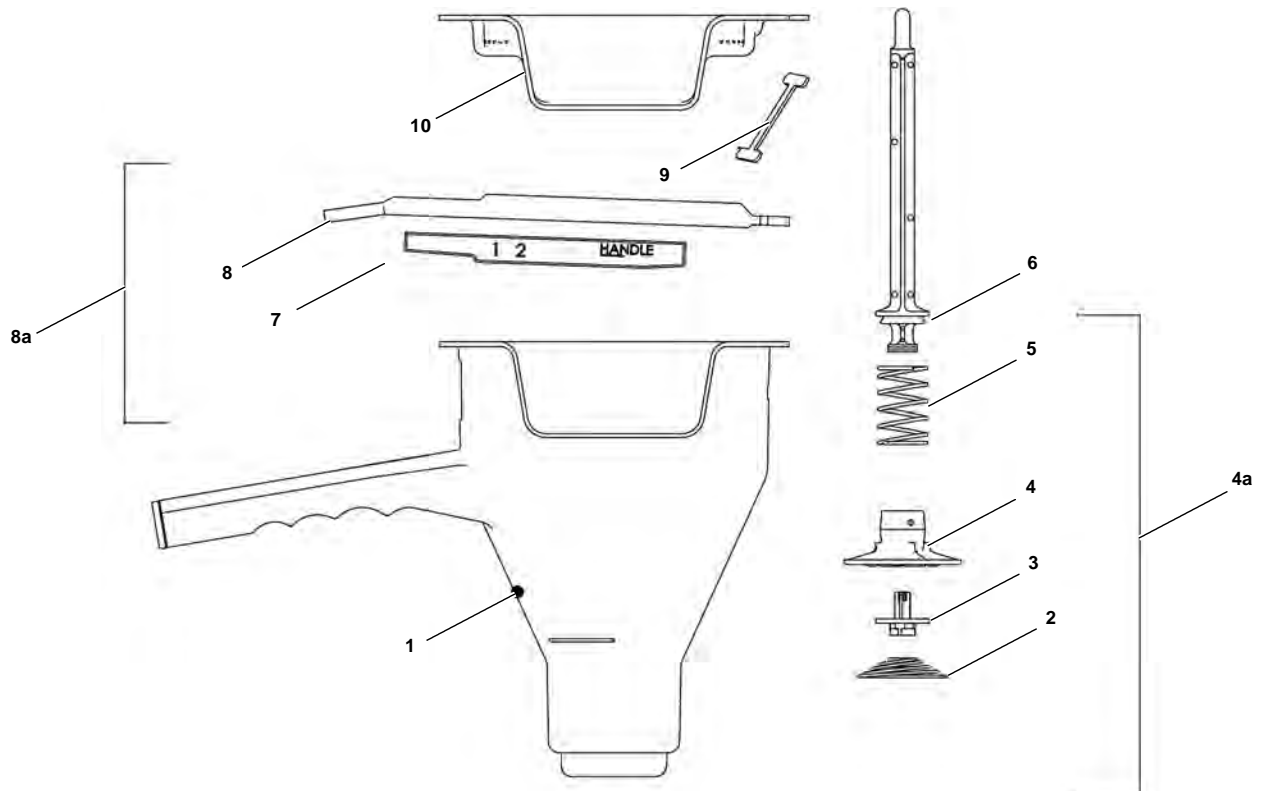

Mustard Dispenser Model No. 398-CN

Parts Kits

| Part No. | Description | Qty |
|--|-----------------------|-----|
| 398-CN Entire Dispenser | | |
| 398-112 | Container with Handle | 1 |
| 404-7 | Check Valve Spring | 1 |
| 398-034 | Check Valve | 1 |
| 398-091 | Cylinder | 1 |
| 398-20 | Piston Spring | 1 |
| 398-032 | Piston Push Rod | 1 |
| 398-031 | Adjusting Cam | 1 |
| 398-033 | Lever | 1 |
| 406-152 | Lid | 1 |
| 404-13 | Tether | 1 |
| 398-032S Upgrade Kit | | |
| 404-7 | Check Valve Spring | 1 |
| 398-034 | Check Valve | 1 |
| 398-091 | Cylinder | 1 |
| 398-032 | Piston Push Rod | 1 |
| 398-031 | Adjusting Cam | 1 |
| 398-033 | Lever | 1 |
| 398-20 | Piston Return Spring | 1 |
| 398-033S Adjusting Cam Kit | | |
| 398-031 | Adjusting Cam | 1 |
| 398-033 | Lever | 1 |
| 398-091S Cylinder, Valve and Spring Kit | | |
| 404-7 | Check Valve Spring | 1 |
| 398-034 | Check Valve | 1 |
| 398-091 | Cylinder | 1 |
| 398-20 | Piston Spring | 1 |

| Part No. | Description | Qty |
|---|----------------------|-----|
| 398-034NS Spare Parts Kit | | |
| 404-7 | Check Valve Spring | 3 |
| 398-034 | Check Valve | 3 |
| 398-091 | Cylinder | 2 |
| 398-20 | Piston Spring | 2 |
| 398-032 | Piston Push Rod | 2 |
| 398-031 | Adjusting Cam | 1 |
| 398-033 | Lever | 1 |
| 406-152 | Lid, Narrow | 2 |
| 404-13 | Tether | 2 |
| 398-20S Piston Return Spring Kit | | |
| 398-20 | Piston Return Spring | 6 |
| 404-7S Check Valve Spring Kit | | |
| 404-7 | Check Valve Spring | 6 |
| 406-152S Narrow Lid and Tether Kit | | |
| 406-152 | Lid, Narrow | 3 |
| 404-13 | Tether | 3 |
| 404-13S Tether Kit | | |
| 404-13 | Tether | 6 |
| 398-112 Narrow Container | | |
| | | 1 |

Tips on Improving Mustard Dispensing

To ensure that you are always dispensing your mustard properly, perform the following tasks:

- 1 Check holes at bottom of canister to evaluate for damage.**
- Never use any type of object to unclog the dispenser. Foreign objects may cause damage to the dispenser, which could restrict or alter dispensing. A clogged dispenser should only be cleaned using the procedures developed for the 3-compartment sink or in an approved dishwasher.

- 2 Wipe bottom of dispenser frequently with a clean, sanitized towel and then discard this towel into the soiled towel bucket.**
- If mustard is smeared along bottom of canister and left for an extended period of time, the mustard will dry out and clog the holes.

- 3 Monitor how crew is using the dispenser.**
- Crew members sometimes touch the dispenser to the bun, causing mustard to smear along the bottom and ultimately clog.

- 4 Keep lid on dispenser.**
- If lid is not on mustard, the mustard will dry out at the top. When the mustard is almost at empty, this crusty mustard will infiltrate the internal parts and negatively affect pumping.

- 5 Try to fill dispenser with no more than 12 ounces of mustard.**
- Prevents waste and the opportunity for the mustard to harden over time.
When mustard hardens, it becomes more difficult to pump.
 - Dispenser must be cleaned at the end of every day.

- 6 If mustard is not being dispensed, you may need to re-prime or reassemble it.**
- Also, check for broken parts.
 - If dispensers clog during the day, disassemble, clean and sanitize the dispenser.

- 7 If you are not dispensing the correct amount of mustard:**
- Check the calibration.
 - Check the tension of your springs. The springs produce the force of dispensing. Older springs produce less force, which reduces the amount of mustard dispensed.
Replace both the check valve and piston springs every 3-4 months to ensure proper force when dispensing.
 - There may be an air pocket in the piston spring and cylinder area. Remove the lever and cam and gently pull piston rod and assembly parts from mustard to release air. Reassemble the parts.
Because of mustard's unique properties, certain parts may discolor over time. This discoloration does not affect the unit's performance or cause any food safety concerns.

All replacement parts for your dispensers are available through your local KES.

Consejos para mejorar la manera de servir la mostaza

Para asegurarse de que siempre está sirviendo la mostaza correctamente, realice las siguientes tareas:

1 Compruebe los orificios del fondo del recipiente para ver si presentan daños.

- Con el tiempo, cuando el personal limpia los orificios con varios objetos, incluyendo lápices, ganchos para papel y otros objetos cuyo uso original no es para limpiar, los agujeros se dañan, se tapan o se altera la manera de servir.

2 Limpie frecuentemente el fondo del dispensador.

- Si la mostaza se extiende por el fondo del recipiente y se deja por un período de tiempo prolongado, la mostaza se secará y taponará los agujeros.

3 Controle la manera en que el personal utiliza el dispensador.

- Los miembros del personal a veces tocan el pan con el dispensador, causando que la mostaza se extienda por el fondo y como consecuencia se tapone.

4 Mantenga la tapa en el dispensador.

- Si la tapa no está en la mostaza, ésta se secará por la parte de arriba. Cuando el recipiente de mostaza está casi vacío, la mostaza seca se filtra por las partes internas y afecta el bombeo de forma negativa.

5 Intente llenar el dispensador con 12 onzas o menos de mostaza.

- Evita el desperdicio y la necesidad de guardar la mostaza en el refrigerador.
La mostaza se endurece y resulta más difícil de bombear.
- Si se guarda en el refrigerador, entonces el dispensador no se limpiará esa noche.

6 Si la mostaza no se dispensa, puede que necesite volver a cebar o a armarlo.

- Compruebe además si hay piezas rotas.

7 Si no se está dispensando la cantidad correcta de mostaza:

- Compruebe el calibrado.
- Compruebe la tensión de los resortes. Los resortes producen la fuerza para dispensar. Los resortes viejos producen menos fuerza, lo cual reduce la cantidad de mostaza dispensada.
Cambie los resortes cada 3 ó 4 meses para asegurar la fuerza de dispensado adecuada.
- Es posible que haya una burbuja de aire en el resorte del pistón y el área del cilindro. Retire la palanca y la leva y tire suavemente de la varilla del pistón y las piezas del conjunto para sacarlos de la mostaza a fin de sacar el aire. Vuelva a armar las piezas.

Debido a las propiedades exclusivas de la mostaza, ciertas piezas podrían decolorarse con el tiempo. Esta decoloración no afecta el rendimiento de la unidad ni es motivo de preocupación por la higiene de los alimentos.

Suggestions pour une meilleure distribution de la moutarde

Pour garantir une distribution uniforme de la moutarde, procédez comme suit :

- 1** Vérifiez les trous de distribution en bas du conteneur. Évaluez les dommages.
- Au fur et à mesure que le personnel nettoie les trous à l'aide de divers objets, y compris stylos, trombones qui n'ont pas été conçus pour le nettoyage, les trous subissent des dommages qui restreignent ou modifient la distribution.

- 2** Nettoyez fréquemment le bas du distributeur.
- Si la moutarde étalée en bas du conteneur n'est pas nettoyée pendant une période prolongée, elle sèche et bouche les trous.

- 3** Surveillez la façon dont le personnel se sert du distributeur.
- Le personnel touche parfois le distributeur avec le pain, ce qui force la moutarde à s'étaler au fond du conteneur et à boucher les trous.

- 4** Le couvercle doit toujours se trouver sur le distributeur.
- Si le couvercle n'est pas sur la moutarde, elle séchera au-dessus. Lorsque le conteneur de moutarde est pratiquement vide, la couche dure de la moutarde s'infiltrera dans les pièces internes et affecte l'action de pompage.

- 5** Remplissez le distributeur de moutarde d'une quantité supérieure à 12 oz.
- Éliminez le gâchis et le besoin de réfrigérer la moutarde pendant la nuit.
La moutarde durcit et il est de plus en plus difficile de pomper.
 - Si la moutarde est placée au réfrigérateur, le distributeur ne sera pas nettoyé cette nuit-là.

- 6** Si la moutarde ne sort pas, vous devez réamorcer le système ou le réassembler.
- Vérifiez également qu'il n'y a pas de pièces cassées.

- 7** Si vous n'obtenez pas la quantité correcte de moutarde, procédez comme suit.
- Vérifiez l'étalonnage.
 - Vérifiez la tension des ressorts. Les ressorts exercent la force nécessaire à la distribution. Les ressorts anciens exercent moins de force ce qui réduit la quantité de moutarde distribuée.
Remplacez les ressorts tous les 3 ou 4 mois pour garantir une force correcte à la distribution.
 - Il peut y avoir une poche d'air dans la zone du ressort du piston et du cylindre. Retirez le levier et la came. Tirez soigneusement sur la tige du piston et sur les pièces pour les séparer de la moutarde et laissez l'air s'échapper. Réassemblez les pièces.

En raison des propriétés particulières de la moutarde, certaines pièces peuvent être décolorées avec le temps. Toutefois, cette décoloration n'affecte pas la performance de l'unité et ne représente pas de source de danger pour la nourriture.

Mustard Dispenser Assembly and Calibration Instructions

Assembly

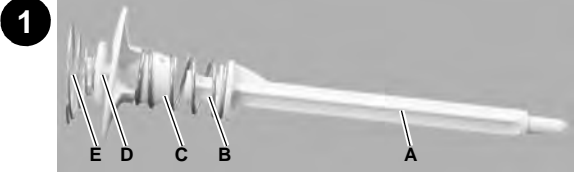

Assemble the mustard rod, ensuring that all springs are completely fastened. Parts include:

- A. Mustard rod
- B. Piston return spring
- C. Mustard cylinder
- D. Check valve
- E. Check valve spring

Note: All of the plastic pieces should be white to ensure optimal performance. Because of the natural properties of mustard, it is not unusual for these parts to be stained by mustard.

2 Insert the plunger rod assembly into the canister.



3 Place the lever into the adjusting cam and set initially at setting 3. To set correctly, ensure that "HANDLE" on the adjusting cam is facing toward the canister's handle (see inset). Insert the plunger rod into the adjusting cam/lever hole.



4 Attach the lid to the canister by using the tether.



Calibration

1 Fill and prime dispenser per Setup instructions on page 2.



2 With adjusting cam set at setting 3, depress rod to dispense mustard into the Brix cup. The target spec is 45-50 shots per ounce (30 mL).



3 If you do not attain the target spec, move the cam to adjust dispense amount.

To increase the amount dispensed (reduce number of shots per ounce), move cam to a higher number.

To decrease the amount dispensed (increase number of shots per ounce), move cam to a lower number.

Note: Settings 1 and 2 are on the other side of the adjusting cam.

