

**DICE-WITCH
PRINCE CASTLE MODEL NO. 910-A Series**

MANUFACTURED
BY
PRINCE CASTLE INC.
CAROL STREAM, IL 60188 USA
PHONE 1-630-462-8800
TOLL FREE NUMBER
1-800-722-7853
FAX: 1-630-462-1460



TABLE OF CONTENTS

WARRANTY	Page 1
INTRODUCTION	Page 2
PARTS IDENTIFICATION/FUNCTION	Page 2
EXPLODED VIEW	Page 3
EQUIPMENT SET-UP AND CLOSE PROCEDURES	Page 3
TROUBLESHOOTING	Page 5
NON-SCHEDULED MAINTENANCE	Page 5
ORDERING/SERVICE INFORMATION	Page 5

WARRANTY

This product is warranted to be free from defects in workmanship for a period of 1 year from date of original installation, not to exceed 18 months from date of manufacture with the exception of the blade cartridge/ blades. Blades cartridge/ blades are warranted to be free from defects at the time of delivery only. Any component which proves to be faulty during the warranty period will be replaced without cost to the customer for parts only.

This warranty is subject to the following conditions:

This unit considered carry in; charges for on-location service (e.g., trip charges, mileage and labor) are not included under the provisions of this warranty.

Damage caused by carelessness, neglect, and/or abuse (e.g., dropping, tampering with or altering parts) voids this warranty.

Blades are warranted to be free from defects in material and/or workmanship at the time of delivery only.

INTRODUCTION

The Dice Witch® is used for portion-control dicing of tomatoes. The pusher head is raised to the top of the guide rods. The sliced tomato is placed between the pusher head and the blade. The pusher head handle is pushed down with a quick, firm stroke until the pusher head stops. Tomatoes are diced in either 3/8" cubes (10 mm) or 3/4" cubes (20mm) depending on model.

Hazard Communication Standard (HCS)– Procedures in this equipment manual include the use of chemical products. These chemical products will be highlighted with bold face letters followed by the abbreviation (HCS) in the text of the manual. See the Hazard Communication Standard (HCS) Manual for the appropriate Material Safety Data Sheet(s) (MSDS).

PARTS IDENTIFICATION/FUNCTION

ITEM	PART	DESCRIPTION	QTY.	FUNCTION
1	910-34S	Complete Pusher Head Assembly (Consists of Items A, B, C)	1	Guides the product through the blades.
A		Pusher Head Handle	1	
B		Thumbscrew	2	
C	910-38S	Pusher Head	1	
2	76-582S	Thumbscrew (Pkg. of 2)	2	Secures blade cover to base.
3	910-39	Blade Cover	1	Holds blade assembly to base.
4	910-50	3/8" Replacement Blade Set	1	Provides the cutting edge for dicing. 3/8" spacing blades for 910-A dicers
5	910-8	Guide Rod Cushions (Pkg. of 2)	2	Cushions the downward motion of the pusher head at end of stroke.
6	89-959S	Rubber Feet (Pkg. of 4)	4	Attaches to legs of base and provides non-scratch contact points with table.
7	908-65S	Base Assembly	1	Supports pusher head and guide rods.
8	953	Core It	1	Used to remove cores and blemishes from tomatoes.

EXPLODED VIEW

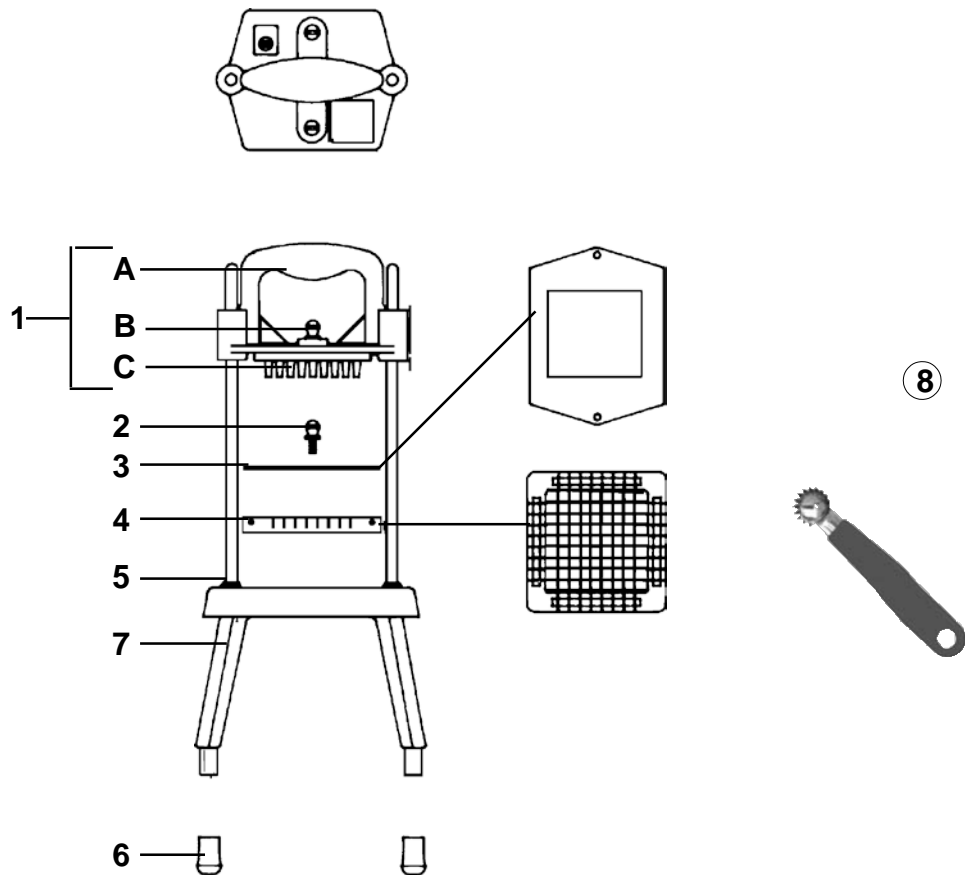

EQUIPMENT SET-UP, DICING AND CLEANING PROCEDURES

1. Ask manager for number of tomatoes to be diced.
2. Check tomatoes for proper condition (no bruises, scarring or mold).
3. Place tomatoes to be sliced and diced in a clean, sanitized colander. Take colander to food prep table, rinse with cold water and drain.
4. Slice tomatoes using a tomato slicer. See figure 1.
5. Place Dice Witch® on the clean, sanitized food prep table. Do not use the back sink as a slicing area.
6. Lubricate guide rods with Petrogel, Taylor Lube or Lubrifilm (HSC) before dicing the first product of the day.

figure 1

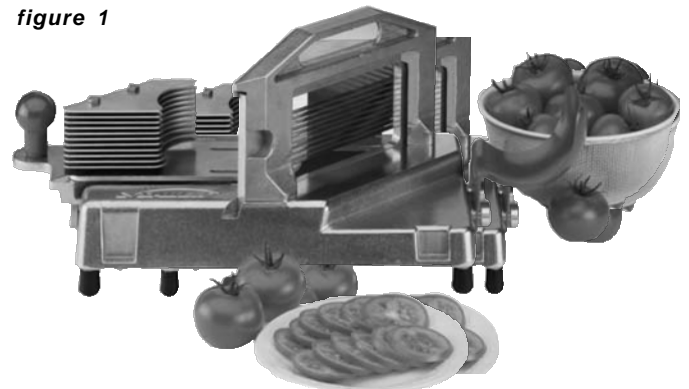

IMPORTANT: Make sure thumbscrews on blade cover are tight before dicing.

7. Place a clean, sanitized $\frac{1}{8}$ " size tomato pan with false bottom under the dicer.
8. Discard end pieces and slices with green core centers showing.

IMPORTANT: If rubber feet are missing the Dice Witch® will slide during the cutting process.

9. Grasp the handle and pull all the way up to end of guide rods.

10. Insert tomato with core side down. See figure 2.

figure 2



CAUTION: Blades are extremely sharp. Keep fingers away from blades.

11. Push handle down with a quick, firm stroke until the pusher head stops. The tomatoes should be completely diced. See figure 3.

figure 3



IMPORTANT: Use the tongs provided to remove leftover tomato from blades, move it to the center of the dicer, and re-dice.

12. Place pan at prep table. Additional pans should be covered and placed in walk-in cooler. (Maximum 3 hour total holding time, with no longer than 1 hour in walk-in cooler, and no more than 2 hours at prep table.)

13. Clean and sanitize Dice Witch® and food prep table.

CLEANING



CAUTION: Blades are very sharp. Handle with extreme care.

Daily cleaning of the Dice Witch® will keep this piece of equipment clean and free of build-up. If residual tomato juice is allowed to remain on the Dice Witch® for long periods, however, a hard white deposit will form on the cutting blades which is very hard to remove. The following procedure will remove any hard white deposits from the blades.

The following cleaning procedures should be conducted after each use:

1. Spray the blade assembly and pusher head with hot water to remove residue. This unit is not dishwasher safe.
2. Brush the pusher head and blades with the Nylon pot brush and a hot solution of All Purpose Cleaner (HCS).
3. Rinse by spraying with hot water.
4. Sanitize by immersing the whole assembly in SANITIZER (HCS) solution.
5. Let air dry.

TROUBLESHOOTING CHART

PROBLEM	PROBABLE CAUSE	CORRECTIVE ACTION
Pusher head is hard to push.	Friction on guide rods.	Lubricate guide rods.
Pusher head hitting blades.	Thumbscrews on pusher head assy. loose.	Tighten thumbscrews on pusher head assy.
Tomatoes not dicing.	Blades dull.	Replace blades. (See page 6.)

NON-SCHEDULED MAINTENANCE REPLACING BLADES

1. Remove pusher head from unit.
 2. Remove the two thumbscrews (Item 2 in exploded view) and the blade cover (Item 3 in exploded view) from unit.
-  **CAUTION: Blades are very sharp, handle with extreme care.**
3. Remove old blade set by pushing blade frame up and out from bottom of unit.
 4. Discard old blade set.
 5. Place new blade set in unit with sharp edges of blades facing up.
 6. Place blade cover on top of blade set and tighten the two thumbscrews.

An extra set of blades is advisable to ensure little or no dicing interruptions with your Dice Witch . These may be ordered from your Prince Castle Service Center. Order Part No. 910-50 for 910-A dicers, or 910-50-1 for 910-AD dicers.

ORDERING/SERVICE INFORMATION

1. WHERE AND HOW TO ORDER REPLACEMENT PARTS

To order replacement parts, look on the back of your Prince Castle Price List for the name and phone number of your local Prince Castle Service Center. You may also call Prince Castle at 1-800-323-2930 (or fax us at 630-462-1460) for the name of your local Service Center.

2. PARTS RETURNS

To return parts to your Service Center for credit, you must obtain authorization from your Service Center.

IMPORTANT: All warranty situations should be handled by your Prince Castle Service Center.

3. PRICES:

A. All prices are F.O.B. Prince Castle Service Center or F.O.B. factory, Carol Stream, Illinois.

B. All prices are subject to change without notice. These prices are exclusive of all sales taxes or any special taxes which may be levied by federal, state, or city governments.

OUTSIDE THE U.S.

Contact your kitchen equipment supplier or designated repair facility for parts and service.